

RoHS Recast Compliant

M.2 2242 Flash Drive

P100 Product Specifications

March 15, 2016

Version 1.5



Apacer Technology Inc.

1F, No.32, Zhongcheng Rd., Tucheng Dist., New Taipei City, Taiwan, R.O.C

Tel: +886-2-2267-8000 Fax: +886-2-2267-2261

www.apacer.com

Features:

- **Compliance with SATA Interface**
 - Serial ATA Revision 3.1
 - SATA 6.0 Gbps
 - ATA-8 command set
 - Backward compatible with SATA 1.5/3.0 Gbps
- **Capacity**
 - 8, 16, 32, 64 GB
- **Performance***
 - Interface burst read/write: 600 MB/sec
 - Sustained read: up to 500 MB/sec
 - Sustained write: up to 150 MB/sec
- **Flash Management**
 - Built-in hardware ECC
 - Static/dynamic wear-leveling
 - Flash bad-block management
 - S.M.A.R.T.
 - Power failure management
 - ATA secure erase
 - TRIM
- **NAND Flash Type: SLC**
- **Endurance**
 - 8 GB: 140 TBW
 - 16 GB: 280 TBW
 - 32 GB: 560 TBW
 - 64 GB: 1120 TBW
- **Temperature Range**
 - Operating:
 - Standard: 0°C to 70°C
 - Extended: -40°C to 85°C
 - Storage: -40°C to 100°C
- **Supply Voltage**
 - 3.3 V ± 5%
- **Power Consumption***
 - Active mode: 440 mA
 - Idle mode: 105 mA
- **Connector Type**
 - 75-pin SATA-based M.2 module pinout
- **Form Factor**
 - M.2 2242 form factor
 - Dimensions: 42.00 x 22.00 x 3.65, unit: mm
- **Shock & Vibration****
 - Shock: 1,500 G
 - Vibration: 15 G
- **MTBF: >2,000,000 hours**
- **SATA Power Management**
- **Device Sleep Mode (optional)**
- **RoHS Recast Compliant (complies with 2011/65/EU standard)**

*Varies from capacities. The values for performances and power consumptions presented are typical and may vary depending on flash configurations or platform settings. The term idle refers to the standby state of the device.

**Non-operating

Table of Contents

1. GENERAL DESCRIPTION	3
2. PIN ASSIGNMENTS	3
3. PRODUCT SPECIFICATIONS	6
3.1 CAPACITY	6
3.2 PERFORMANCE	6
3.3 ENVIRONMENTAL SPECIFICATIONS	7
3.4 MEAN TIME BETWEEN FAILURES (MTBF)	7
3.5 CERTIFICATION AND COMPLIANCE	7
4. FLASH MANAGEMENT	8
4.1 ERROR CORRECTION/DETECTION	8
4.2 BAD BLOCK MANAGEMENT	8
4.3 WEAR LEVELING	8
4.4 POWER FAILURE MANAGEMENT.....	8
4.5 ATA SECURE ERASE	8
4.6 TRIM	8
4.7 SATA POWER MANAGEMENT	9
4.8 ENDURANCE	9
5. SOFTWARE INTERFACE	10
5.1 COMMAND SET	10
5.2 S.M.A.R.T.....	11
6. ELECTRICAL SPECIFICATIONS	12
7. MECHANICAL SPECIFICATIONS	13
7.1 DIMENSIONS	13
8. PRODUCT ORDERING INFORMATION	14

1. General Description

Apacer P100 is the next generation modularized Solid State Drive (SSD) with the shape of all new M.2 form factor, with the aim to be the more suitable for mobile and compact computers with standard width at only 22.00 mm. P100 appears in M.2 2242 mechanical dimensions and is believed to be the leading add-in storage solution for future host computing systems.

The M.2 SSD is designed with SATA-based connector pinouts, providing full compliance with the latest SATA Revision 3.1 interface specifications. Aside from SATA compliance, P100 delivers exceptional performance and power efficiency. On the other hand, the extreme thin and light form factor makes P100 the ideal choice for mobile computing systems, which appears to be the trend in near future.

Regarding reliability, P100 is built with a powerful SATA controller that supports on-the-module ECC as well as efficient wear leveling scheme. Since it is operating under SATA 6.0 Gbps interface, P100 is provided with Apacer latest S.M.A.R.T. that are primarily oriented for the latest SATA interface SSD, for drive lifetime monitoring and analyzing.

2. Pin Assignments

This connector does not support hot plug capability. There are a total of 75 pins. 12 pin locations are used for mechanical key locations; this allows such a module to plug into both Key B and Key M connectors.



Pin	Type	Description
1	CONFIG_3	Ground (according to M.2 configurations for SSD-SATA definition)
2	3.3V	Supply Pin, 3.3V
3	GND	Ground
4	3.3V	Supply pin, 3.3V
5	No connect	No connect
6	Not available	No connect (used for other purposes)
7	Not available	No connect (used for other purposes)
8	Not available	No connect (used for other purposes)

M.2 2242 Flash Drive APM2T42P100xxxGAN-XTX

Pin	Type	Description
9	No connect	No connect
10	DAS/DSS	Device Activity Signal/Disable Staggered Spin-up
11	No connect	No connect (used for other purposes)
12	(removed for key)	Mechanical notch B
13	(removed for key)	Mechanical notch B
14	(removed for key)	Mechanical notch B
15	(removed for key)	Mechanical notch B
16	(removed for key)	Mechanical notch B
17	(removed for key)	Mechanical notch B
18	(removed for key)	Mechanical notch B
19	(removed for key)	Mechanical notch B
20	Not available	No connect (used for other purposes)
21	CONFIG_0	Ground (according to M.2 configurations for SSD-SATA definition)
22	Not available	No connect (used for other purposes)
23	Not available	No connect (used for other purposes)
24	Not available	No connect (used for other purposes)
25	Not available	No connect (used for other purposes)
26	Not available	No connect (used for other purposes)
27	GND	Ground
28	Not available	No connect (used for other purposes)
29	PERn1	Not used
30	Not available	No connect (used for other purposes)
31	PERp1	Not used
32	Not available	No connect (used for other purposes)
33	GND	Ground
34	Not available	No connect (used for other purposes)
35	PETn1	Not used
36	Not available	No connect (used for other purposes)
37	PETp1	Not used
38	DEVSLP	Device Sleep, input. If driven high the host is informing the SSD to enter a low power state
39	GND	Ground
40	Not available	No connect (used for other purposes)
41	SATA-Rx+	Host receiver differential signal pair
42	Not available	No connect (used for other purposes)
43	SATA-Rx-	Host receiver differential signal pair

M.2 2242 Flash Drive APM2T42P100xxxGAN-XTX



Pin	Type	Description
44	Not available	No connect (used for other purposes)
45	GND	Ground
46	Not available	No connect (used for other purposes)
47	SATA-Tx-	Host transmitter differential pair
48	Not available	No connect (used for other purposes)
49	SATA-Tx+	Host transmitter differential pair
50	PERST#	Not used
51	GND	Ground
52	CLKREQ#	Not used
53	REFCLKN	Not used
54	PEWAKE#	Not used
55	REFCLKP	Not used
56	MFG1	Manufacturing pin. Use determined by vendor (no connect on a host)
57	GND	Ground
58	MFG2	Manufacturing pin. Use determined by vendor (no connect on a host)
59	(removed for key)	Mechanical notch M
60	(removed for key)	Mechanical notch M
61	(removed for key)	Mechanical notch M
62	(removed for key)	Mechanical notch M
63	(removed for key)	Mechanical notch M
64	(removed for key)	Mechanical notch M
65	(removed for key)	Mechanical notch M
66	(removed for key)	Mechanical notch M
67	Not available	No connect (used for other purposes)
68	SUSCLK	Not used
69	CONFIG_1	Ground
70	3.3V	Supply pin, 3.3V
71	GND	Ground
72	3.3V	Supply pin, 3.3V
73	GND	Ground
74	3.3V	Supply pin, 3.3V
75	CONFIG_2	Ground

3. Product Specifications

3.1 Capacity

Capacity specification of P100 is available as shown in Table 3-1. It lists the specific capacity and the default numbers of heads, sectors and cylinders for each product line.

Table 3-1 Capacity Specifications

Capacity	Total bytes*	Cylinders	Heads	Sectors	Max LBA
8 GB	8,012,390,400	15,525	16	63	15,649,200
16 GB	16,013,942,784	16,383	16	63	31,277,232
32 GB	32,017,047,552	16,383	16	63	62,533,296
64 GB	64,023,257,088	16,383	16	63	125,045,424

*Display of total bytes varies from file systems, which means not all of the bytes can be used for storage.

**Notes: 1 GB = 1,000,000,000 bytes; 1 sector = 512 bytes.

LBA count addressed in the table above indicates total user storage capacity and will remain the same throughout the lifespan of the device. However, the total usable capacity of the SSD is most likely to be less than the total physical capacity because a small portion of the capacity is reserved for device maintenance usages.

3.2 Performance

Performances of P100 are listed below in Table 3-2.

Table 3-2 Performance

Capacity \ Performance	8 GB	16 GB	32 GB	64 GB
Sustained read (MB/s)	285	500	500	500
Sustained write (MB/s)	85	145	150	150

Note: Results may differ from various flash configurations or host system setting.

3.3 Environmental Specifications

Environmental specification of P100 series follows MIL-STD-810, as shown in Table 3-3.

Table 3-3 Environmental Specifications

Item	Specifications
Temperature	0°C to 70°C (Operating) / -40°C to 85°C (Extended)
	-40°C to 85°C (in storage)
Shock	1,500G, 0.5ms
Vibration	20Hz~80Hz/1.52mm (frequency/displacement)
	80Hz~2000Hz/20G (frequency/displacement) X, Y, Z axis/60mins each
Drop	80cm free fall, 6 face of each
Bending	≥20N, hold 1min/5times
Torque	0.5N-m or 5deg, hold 5min/5times
ESD	Pass

3.4 Mean Time Between Failures (MTBF)

Mean Time Between Failures (MTBF) is predicted based on reliability data for the individual components in P100. The prediction result for P100 is more than 2,000,000 hours.

Note: The MTBF is predicated and calculated based on “Telcordia Technologies Special Report, SR-332, Issue 2” method.

3.5 Certification and Compliance

P100 complies with the following standards:

- CE
- FCC
- RoHS Recast
- MIL-STD-810
- BSMI

4. Flash Management

4.1 Error Correction/Detection

P100 implements a hardware ECC scheme, based on the BCH algorithm. It can detect and correct up to 72 bits error in 1K bytes.

4.2 Bad Block Management

Bad blocks are blocks that include one or more invalid bits, and their reliability is not guaranteed. Blocks that are identified and marked as bad by the manufacturer are referred to as “Initial Bad Blocks”. Bad blocks that are developed during the lifespan of the flash are named “Later Bad Blocks”. Apacer implements an efficient bad block management algorithm to detect the factory-produced bad blocks and manages any bad blocks that appear with use. This practice further prevents data being stored into bad blocks and improves the data reliability.

4.3 Wear Leveling

NAND flash devices can only undergo a limited number of program/erase cycles, and in most cases, the flash media are not used evenly. If some areas get updated more frequently than others, the lifetime of the device would be reduced significantly. Thus, Wear Leveling is applied to extend the lifespan of NAND flash by evenly distributing write and erase cycles across the media.

Apacer provides advanced Wear Leveling algorithm, which can efficiently spread out the flash usage through the whole flash media area. Moreover, by implementing both dynamic and static Wear Leveling algorithms, the life expectancy of the NAND flash is greatly improved.

4.4 Power Failure Management

Power Failure Management plays a crucial role when experiencing unstable power supply. Power disruption may occur when users are storing data into the SSD. In this urgent situation, the controller would run multiple write-to-flash cycles to store the metadata for later block rebuilding. This urgent operation requires about several milliseconds to get it done. At the next power up, the firmware will perform a status tracking to retrieve the mapping table and resume previously programmed NAND blocks to check if there is any incompleteness of transmission.

4.5 ATA Secure Erase

ATA Secure Erase is a standard ATA command and will write all “0xFF” to fully wipe all the data on hard drives and SSDs. When this command is issued, the SSD controller will empty its storage blocks and return to its factory default settings.

4.6 TRIM

TRIM is a feature which helps improve the read/write performance and speed of solid-state drives (SSD). Unlike hard disk drives (HDD), SSDs are not able to overwrite existing data, so the available space gradually becomes smaller with each use. With the TRIM command, the operating system can inform the SSD which blocks of data are no longer in use and can be removed permanently. Thus, the SSD will perform the erase action, which prevents unused data from occupying blocks all the time.

4.7 SATA Power Management

By complying with SATA 6.0 Gb/s specifications, the SSD supports the following SATA power saving modes:

- ACTIVE: PHY ready, full power, Tx & Rx operational
- PARTIAL: Reduces power, resumes in under 10 μ s (microseconds)
- SLUMBER: Reduces power, resumes in under 10 ms (milliseconds)
- HIPM: Host-Initiated Power Management
- DIPM: Device-Initiated Power Management
- AUTO-SLUMBER: Automatic transition from partial to slumber.
- Device Sleep (DevSleep or DEVSLP): PHY powered down; power consumption \leq 5 mW; host assertion time \leq 10 ms; exit timeout from this state \leq 20 ms (unless specified otherwise in SATA Identify Device Log).

Note:

1. The behaviors of power management features would depend on host/device settings.
2. Device Sleep mode is optional, depending on product ordering selections.

4.8 Endurance

The endurance of a storage device is predicted by Tera Bytes Written based on several factors related to usage, such as the amount of data written into the drive, block management conditions, and daily workload for the drive. Thus, key factors, such as Write Amplifications and the number of P/E cycles, can influence the lifespan of the drive.

Capacity	Tera Bytes Written
8 GB	140
16 GB	280
32 GB	560
64 GB	1120

Notes:

- The measurement assumes the data written to the SSD for test is under a typical and constant rate.
- The measurement follows the standard metric: 1 TB (Terabyte) = 1,000 GB.
- This estimation complies with JEDEC JESD-219, enterprise endurance workload of random data with payload size distribution.

5. Software Interface

5.1 Command Set

This section defines the software requirements and the format of the commands the host sends to P100. Commands are issued to P100 by loading the required registers in the command block with the supplied parameters, and then writing the command code to the Command register.

Table 5-1 Command Set

Command	Code	Command	Code
NOP	00h	Idle	97h
Data Set Management	06h	Check Power Mode	98h
Recalibrate	10f-1Fh	Sleep	99h
Read Sectors	20h	SMART	B0h
Read Sectors without Retry	21h	Device Configuration	B1h
Read Sectors EXT	24h	Read Multiple	C4h
Read DMA EXT	25h	Write Multiple	C5h
Read Native Max Address EXT	27h	Set Multiple Mode	C6h
Read Multiple EXT	29h	Read DMA	C8h
Read Log EXT	2Fh	Read DMA without Retry	C9h
Write Sectors	30h	Write DMA	CAh
Write Sectors Without Retry	31h	Write DMA without Retry	CBh
Write Sectors EXT	34h	Write Multiple FUA EXT	CEh
Write DMA EXT	35h	Standby Immediate	E0h
Set Native Max Address EXT	37h	Idle Immediate	E1h
CFA Write Sectors without erase	38h	Standby	E2h
Write Multiple EXT	39h	Idle	E3h
Write DMA FUA EXT	3Dh	Read Buffer	E4h
Write Long EXT	3Fh	Check Power Mode	E5h
Read Verify Sectors	40h	Sleep	E6h
Read Verify Sectors without Retry	41h	Flush Cache	E7h
Read Verify Sectors EXT	42h	Write Buffer	E8h
Write Uncorrectable EXT	45h	Flush Cache EXT	EAh
Read FPDMA Queued	60h	Identify Device	ECh
Write FPDMA Queued	61h	Set Features	EFh
Seek	70h-7Fh	Security Set Password	F1h
Execute Device Diagnostic	90h	Security Unlock	F2h
Initialize Device Parameters	91h	Security Erase Prepare	F3h

M.2 2242 Flash Drive APM2T42P100xxxGAN-XTX



Command	Code	Command	Code
Download Microcode	92h	Security Erase Unit	F4h
Download Microcode DMA	93h	Security Freeze Lock	F5h
Standby Immediate	94h	Security Disable Password	F6h
Idle Immediate	95h	Read Native Max Address	F8h
Standby	96h	Set Max Address	F9h

5.2 S.M.A.R.T.

SMART, an acronym for Self-Monitoring, Analysis and Reporting Technology, is an open standard that allows a hard disk drive to automatically detect its health and report potential failures. When a failure is recorded by SMART, users can choose to replace the drive to prevent unexpected outage or data loss. Moreover, SMART can inform users of impending failures while there is still time to perform proactive actions, such as copy data to another device.

6. Electrical Specifications

Table 6-1 Operating Range

Ambient Temperature	0°C to 85°C
Supply Voltage	3.3V ± 5% (3.135-3.465V)

Table 6-2 Typical Power Consumption

Modes \ Capacity	8 GB	16 GB	32 GB	64 GB
Active (mA)	320	320	410	440
Idle (mA)	100	100	100	105

Note: Results may differ from various flash configurations or host system setting.

7. Mechanical Specifications

7.1 Dimensions

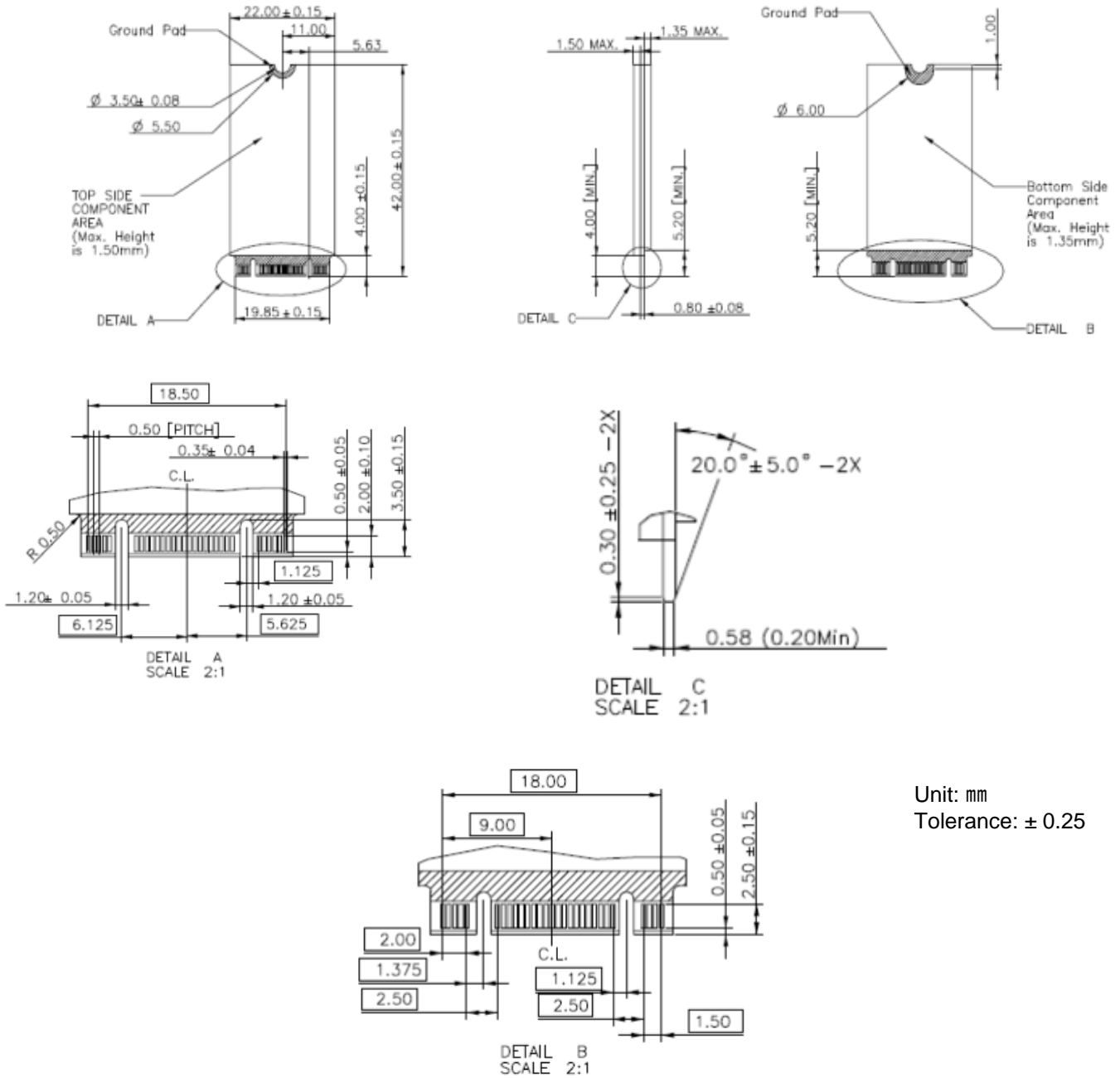

Unit: mm
 Tolerance: ± 0.25

8. Product Ordering Information

8.1 Product Code Designations

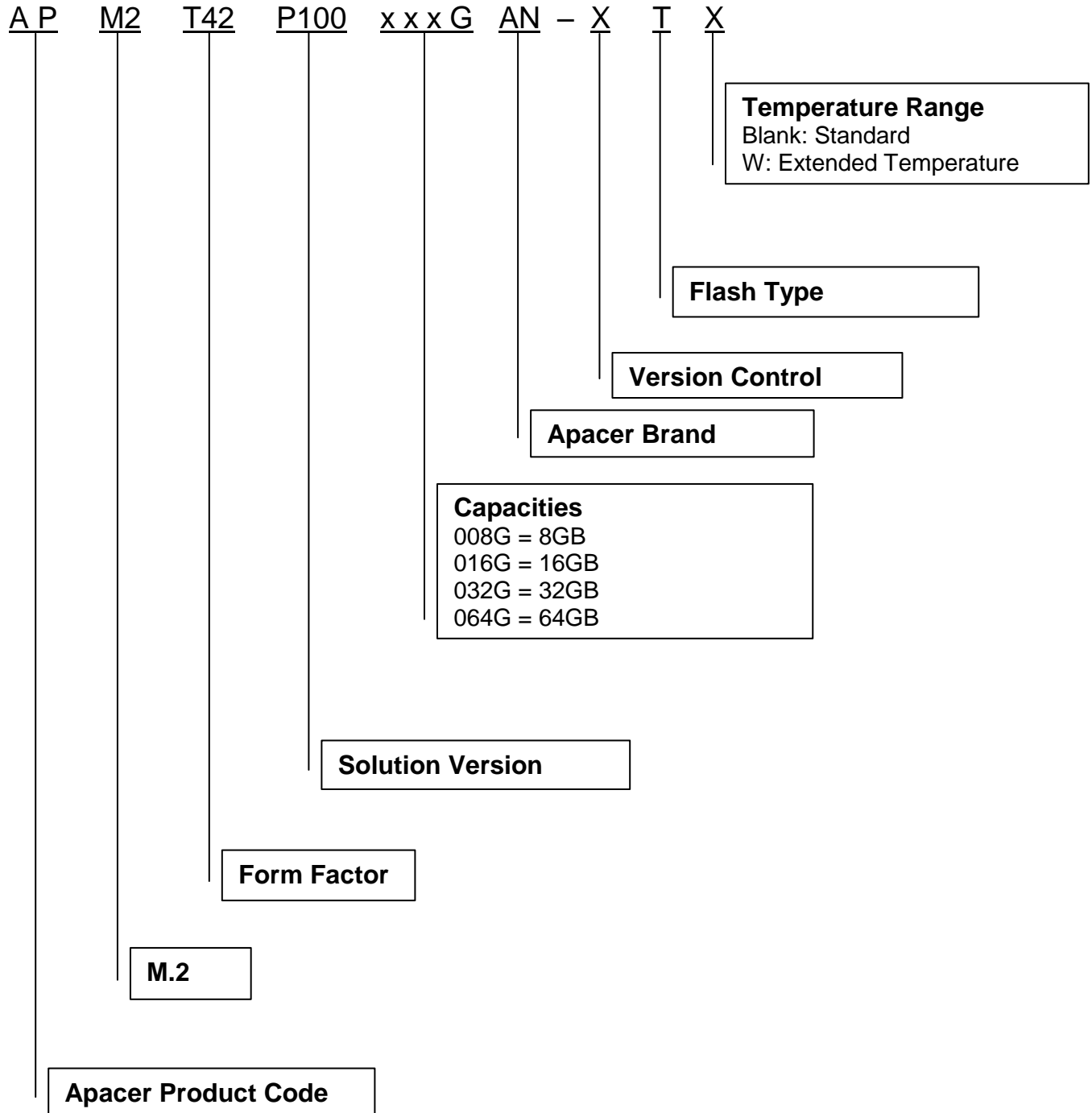

8.2 Valid Combinations

8.2.1 Standard Temperature

Capacity	No DEVSLP
8GB	APM2T42P100008GAN-IT
16GB	APM2T42P100016GAN-IT
32GB	APM2T42P100032GAN-IT
64GB	APM2T42P100064GAN-IT

8.2.2 Extended Temperature

Capacity	No DEVSLP
8GB	APM2T42P100008GAN-ITW
16GB	APM2T42P100016GAN-ITW
32GB	APM2T42P100032GAN-ITW
64GB	APM2T42P100064GAN-ITW

Note: Valid combinations are those products in mass production or will be in mass production. Consult your Apacer sales representative to confirm availability of valid combinations and to determine availability of new combinations.

Revision History

Revision	Date	Description	Remark
0.1	11/03/2014	Preliminary release	
1.0	12/05/2014	Official release	
1.1	06/18/2015	- Revised dimension of feature page: 42.00x22.00x3.75->42.00x22.00x3.65 - Changed power consumption unit: mW->mA	
1.2	06/20/2015	- Added 4GB support - Revised product ordering information	
1.3	11/19/2015	Removed 4 GB support	
1.4	12/29/2015	Revised endurance ratings.	
1.5	3/15/2016	Revised product ordering information	

Global Presence

Taiwan (Headquarters)	Apacer Technology Inc. 1F., No.32, Zhongcheng Rd., Tucheng Dist., New Taipei City 236, Taiwan R.O.C. Tel: 886-2-2267-8000 Fax: 886-2-2267-2261 amtsales@apacer.com
U.S.A.	Apacer Memory America, Inc. 46732 Lakeview Blvd., Fremont, CA 94538 Tel: 1-408-518-8699 Fax: 1-510-249-9568 sa@apacerus.com
Japan	Apacer Technology Corp. 5F, Matsura Bldg., Shiba, Minato-Ku Tokyo, 105-0014, Japan Tel: 81-3-5419-2668 Fax: 81-3-5419-0018 jpservices@apacer.com
Europe	Apacer Technology B.V. Science Park Eindhoven 5051 5692 EB Son, The Netherlands Tel: 31-40-267-0000 Fax: 31-40-267-0000#6199 sales@apacer.nl
China	Apacer Electronic (Shanghai) Co., Ltd Room D, 22/FL, No.2, Lane 600, JieyunPlaza, Tianshan RD, Shanghai, 200051, China Tel: 86-21-6228-9939 Fax: 86-21-6228-9936 sales@apacer.com.cn
India	Apacer Technologies Pvt Ltd, Unit No.201, "Brigade Corner", 7 th Block Jayanagar, Yediyur Circle, Bangalore – 560082, India Tel: 91-80-4152-9061 Fax: 91-80-4170-0215 sales_india@apacer.com

X-ON Electronics

Largest Supplier of Electrical and Electronic Components

Click to view similar products for [Solid State Drives - SSD category](#):

Click to view products by [Apacer manufacturer](#):

Other Similar products are found below :

[SSDSC2CT120A3K5](#) [MTFDDAC512MAM-1K1](#) [SSDPEKKF010T7X1](#) [ATCA7360-MMOD-SATA2](#) [MTFDDAK960MAV-1AEA2AAYYES](#)
[ASD25-MLC064G-CT-160-1](#) [SQF-SM4V2-256G-SBC](#) [SSDSC2BX800G401940785](#) [SD7SN6S-128G-1122](#) [SDLF1DM-800G-1HA1](#)
[SD9SN8W-128G](#) [MTFDDAA120MBB-2AE1ZABYY](#) [SSDSC2KR120H6XN](#) [SM668GXB-ACS O1118](#) [MTFDDAA240MBB-2AE1ZABYY](#)
[SQF-S25V4-240G-SCC](#) [SQF-SDMM2-256G-S9E](#) [SFSA016GQ1BJ8TO-I-DT-226-STD](#) [SFSA060GU2AA2TO-C-LB-216-STD](#)
[MTFDDAK060MBD-1AH12ITYY](#) [VSF202PC016G-100](#) [AF512GSMEL-VABIP](#) [SSDPEKKA020T801](#) [MTFDDAK064MBD-1AH12ITYY](#)
[MTFDDAK800MBP-1AN1ZABYY](#) [EP-SSMSF128AACS](#) [HBRPEKNX0202A01](#) [SSDPE21D015TAX1](#) [SSDPED1D015TAX1](#)
[SSDPEKKF020T8X1](#) [SSDPEKKR256G7XN](#) [SSDPEKKW020T8X1](#) [SSDPEKKW512G801](#) [SSDPEKNW010T801976803](#)
[SSDPEKNW020T801](#) [SSDPEKNW020T9X1](#) [SSDPEL1D380GAX1](#) [SM2280S3G2/120G](#) [MTFDDAK128MBD-1AK12ITYY](#)
[MTFDDAK1T9QDE-2AV1ZABYY](#) [MTFDDAK3T8QDE-2AV1ZABYY](#) [MTFDDAT128MBD-1AK12ITYY](#) [MTFDDAK512TDL-](#)
[1AW1ZABYY](#) [MTFDDAV256TDL-1AW12ABYY](#) [MTFDDAK2T0TDL-1AW1ZABYY](#) [MTFDDAK1T0TDL-1AW12ABYY](#)
[MTFDDAV512TDL-1AW1ZABYY](#) [MTFDDAV256TDL-1AW1ZABYY](#) [MTFDHAL11TATCW-1AR1ZABYY](#) [MTFDHAL12T8TDR-](#)
[1AT1ZABYY](#)