



富鼎先進電子股份有限公司
ADVANCED POWER ELECTRONICS CORP.

Address: 12F-1&2, No.5, Taiyuan 1 ST., Zhubei
City, Hsinchu County 30265, Taiwan,
R.O.C.Tel:886-3-6215899 Fax:886-3-6215999
E-mail:mail@a-power.com.tw

承 認 書

Specification Sheet

Customer :

Customer Part Number	AP9579GP
APEC Part Number	AP9579GP
Issued Date	2020/06/02
SPEC No.	SPEC-202006-0001

APEC Approved		
Sales Manager	Sales	QA

Customer Approved			
Dept.			
Signature			

FP-7201-01C



Item	Contents	Page
1	Data Sheet	p1~p5
2	Package Outline	p6~p7
3	Packing Standard	p8
4	Material List	p9~p10
5	IR Reflow	p11
6	Reliability Test Report + ESD	AnnexI





- ▼ Low On-resistance
- ▼ Simple Drive Requirement
- ▼ Fast Switching Characteristic
- ▼ Halogen Free & RoHS Compliant Product

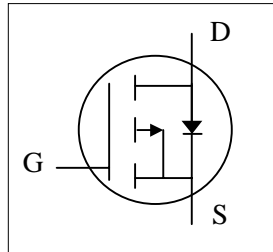

BV_{DSS}	-60V
$R_{DS(ON)}$	25m Ω
I_D	-45A

Description

AP9579 series are from Advanced Power innovated design and silicon process technology to achieve the lowest possible on-resistance and fast switching performance. It provides the designer with an extreme efficient device for use in a wide range of power applications.

The TO-220 package is widely preferred for all commercial-industrial through hole applications. The low thermal resistance and low package cost contribute to the worldwide popular package.

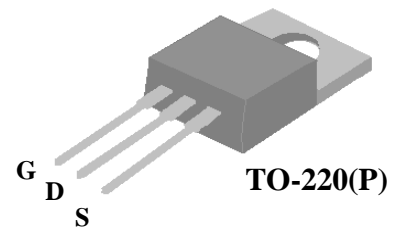

Absolute Maximum Ratings @ $T_j=25^\circ\text{C}$ (unless otherwise specified)

Symbol	Parameter	Rating	Units
V_{DS}	Drain-Source Voltage	-60	V
V_{GS}	Gate-Source Voltage	+20	V
$I_D@T_C=25^\circ\text{C}$	Drain Current, V_{GS} @ 10V	-45	A
$I_D@T_C=100^\circ\text{C}$	Drain Current, V_{GS} @ 10V	-28.7	A
I_{DM}	Pulsed Drain Current ¹	-160	A
$P_D@T_C=25^\circ\text{C}$	Total Power Dissipation	89.3	W
$P_D@T_A=25^\circ\text{C}$	Total Power Dissipation	2	W
T_{STG}	Storage Temperature Range	-55 to 150	$^\circ\text{C}$
T_J	Operating Junction Temperature Range	-55 to 150	$^\circ\text{C}$

Thermal Data

Symbol	Parameter	Value	Units
Rthj-c	Maximum Thermal Resistance, Junction-case	1.4	$^\circ\text{C}/\text{W}$
Rthj-a	Maximum Thermal Resistance, Junction-ambient	62	$^\circ\text{C}/\text{W}$





AP9579GP-HF

Electrical Characteristics @T_j=25°C(unless otherwise specified)

Symbol	Parameter	Test Conditions	Min.	Typ.	Max.	Units
BV _{DSS}	Drain-Source Breakdown Voltage	V _{GS} =0V, I _D =-250uA	-60	-	-	V
R _{DS(ON)}	Static Drain-Source On-Resistance ²	V _{GS} =-10V, I _D =-20A	-	-	25	mΩ
		V _{GS} =-4.5V, I _D =-15A	-	-	30	mΩ
V _{GS(th)}	Gate Threshold Voltage	V _{DS} =V _{GS} , I _D =-250uA	-1	-	-3	V
g _{fs}	Forward Transconductance	V _{DS} =-10V, I _D =-20A	-	36	-	S
I _{DSS}	Drain-Source Leakage Current	V _{DS} =-48V, V _{GS} =0V	-	-	-25	uA
I _{GSS}	Gate-Source Leakage	V _{GS} =±20V, V _{DS} =0V	-	-	±100	nA
Q _g	Total Gate Charge	I _D =-20A	-	45	72	nC
Q _{gs}	Gate-Source Charge	V _{DS} =-48V	-	7.5	-	nC
Q _{gd}	Gate-Drain ("Miller") Charge	V _{GS} =-4.5V	-	26	-	nC
t _{d(on)}	Turn-on Delay Time	V _{DS} =-30V	-	12	-	ns
t _r	Rise Time	I _D =-20A	-	38	-	ns
t _{d(off)}	Turn-off Delay Time	R _G =3.3Ω	-	70	-	ns
t _f	Fall Time	V _{GS} =-10V	-	94	-	ns
C _{iss}	Input Capacitance	V _{GS} =0V	-	3600	5760	pF
C _{oss}	Output Capacitance	V _{DS} =-25V	-	375	-	pF
C _{rss}	Reverse Transfer Capacitance	f=1.0MHz	-	270	-	pF

Source-Drain Diode

Symbol	Parameter	Test Conditions	Min.	Typ.	Max.	Units
V _{SD}	Forward On Voltage ²	I _S =-20A, V _{GS} =0V	-	-	-1.3	V
t _{rr}	Reverse Recovery Time	I _S =-20A, V _{GS} =0V,	-	43	-	ns
Q _{rr}	Reverse Recovery Charge	dI/dt=-100A/μs	-	63	-	nC

Notes:

- 1.Pulse width limited by Max. junction temperature.
- 2.Pulse test

THIS PRODUCT IS SENSITIVE TO ELECTROSTATIC DISCHARGE, PLEASE HANDLE WITH CAUTION.

USE OF THIS PRODUCT AS A CRITICAL COMPONENT IN LIFE SUPPORT OR OTHER SIMILAR SYSTEMS IS NOT AUTHORIZED.

APEC DOES NOT ASSUME ANY LIABILITY ARISING OUT OF THE APPLICATION OR USE OF ANY PRODUCT OR CIRCUIT DESCRIBED HEREIN; NEITHER DOES IT CONVEY ANY LICENSE UNDER ITS PATENT RIGHTS, NOR THE RIGHTS OF OTHERS.

APEC RESERVES THE RIGHT TO MAKE CHANGES WITHOUT FURTHER NOTICE TO ANY PRODUCTS HEREIN TO IMPROVE RELIABILITY, FUNCTION OR DESIGN.

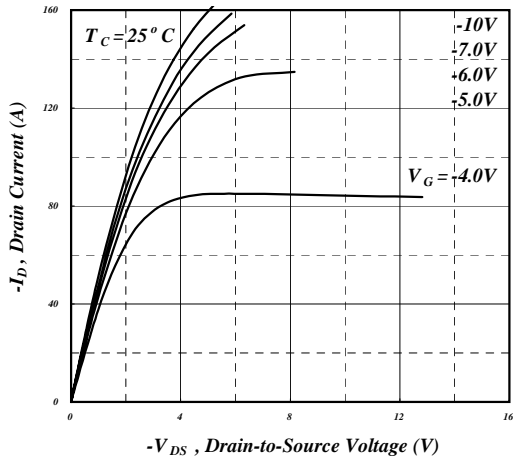

Fig 1. Typical Output Characteristics

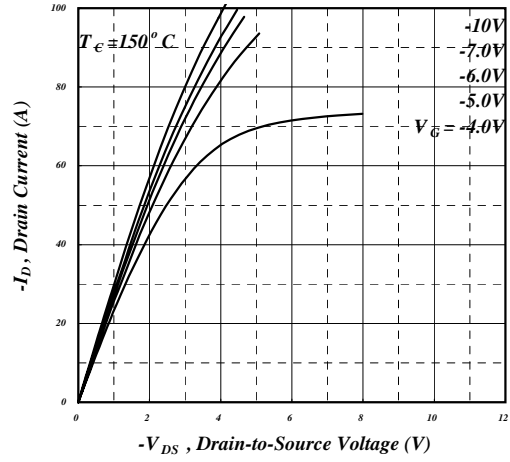

Fig 2. Typical Output Characteristics

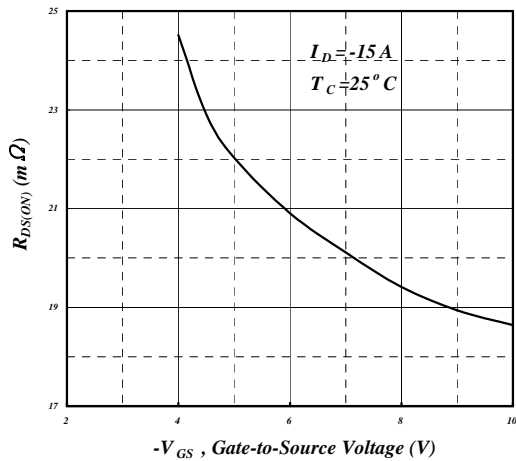

Fig 3. On-Resistance v.s. Gate Voltage

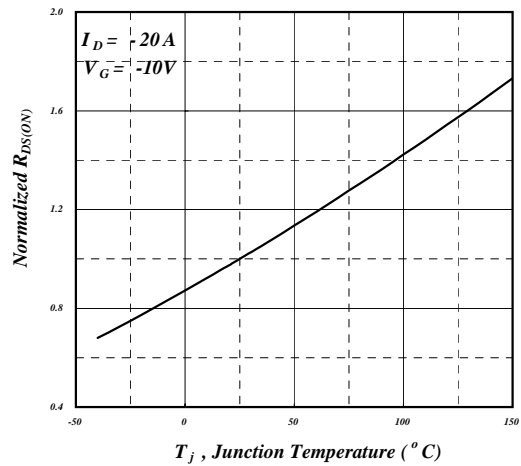

Fig 4. Normalized On-Resistance v.s. Junction Temperature

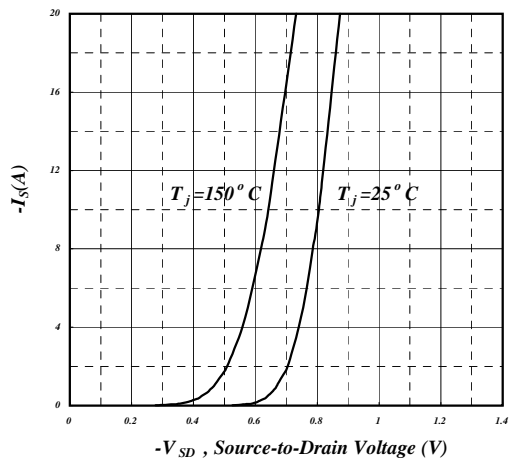

Fig 5. Forward Characteristic of Reverse Diode

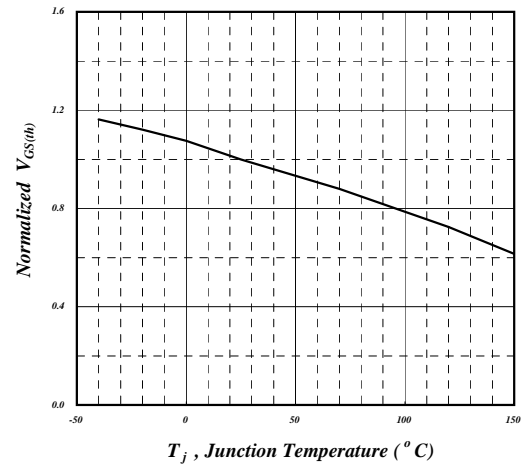

Fig 6. Gate Threshold Voltage v.s. Junction Temperature



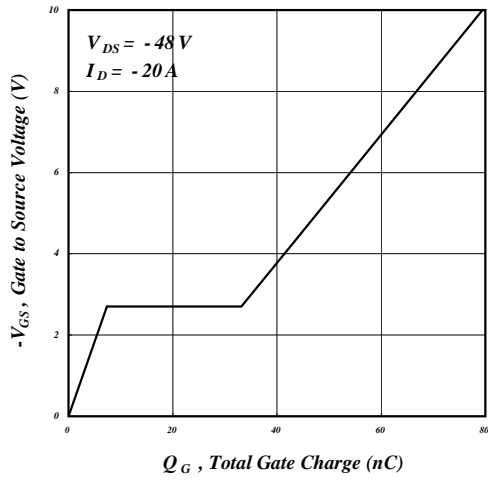

Fig 7. Gate Charge Characteristics

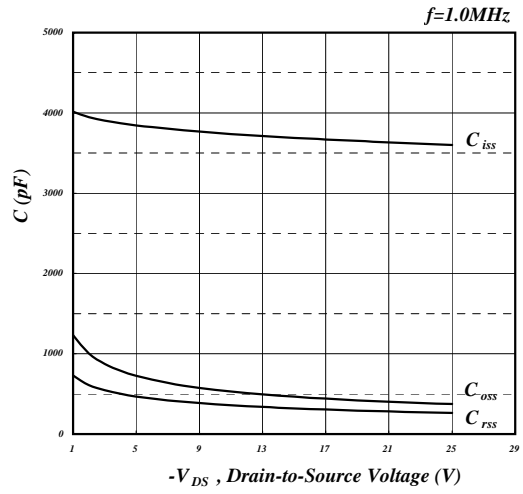

Fig 8. Typical Capacitance Characteristics

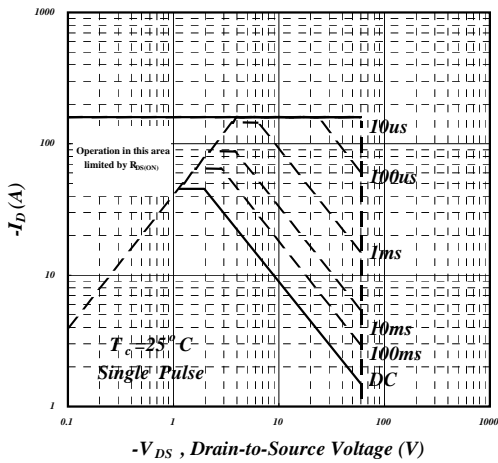

Fig 9. Maximum Safe Operating Area

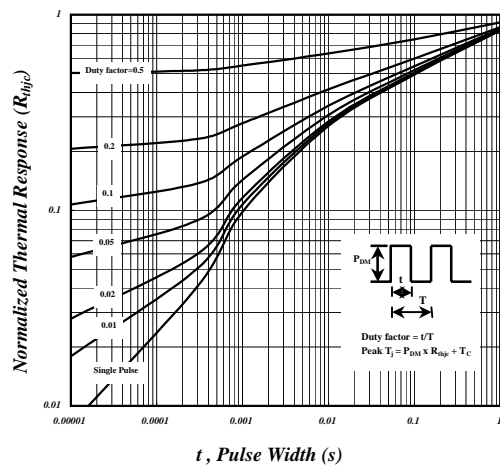

Fig 10. Effective Transient Thermal Impedance

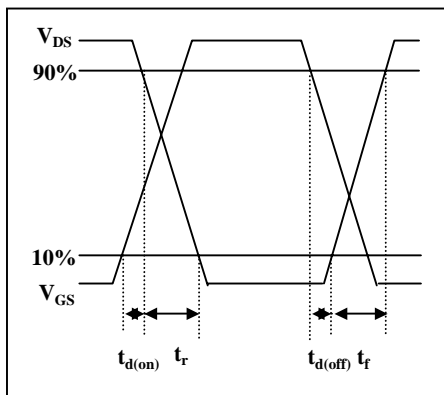

Fig 11. Switching Time Waveform

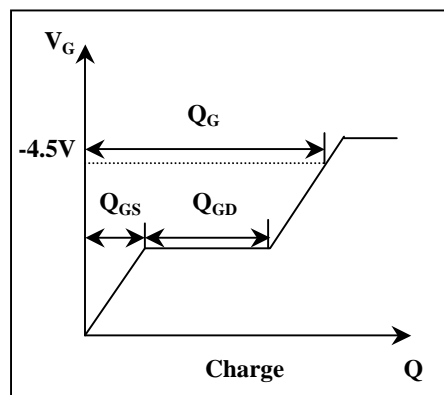
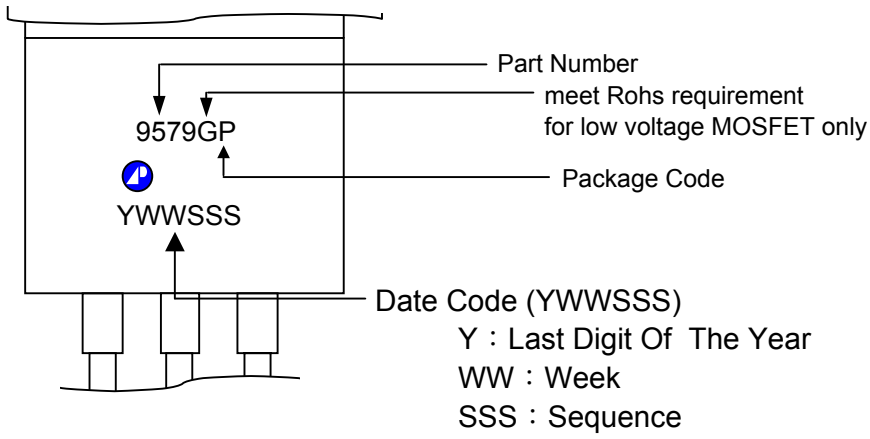

Fig 12. Gate Charge Waveform





MARKING INFORMATION





Package Outline : TO-220

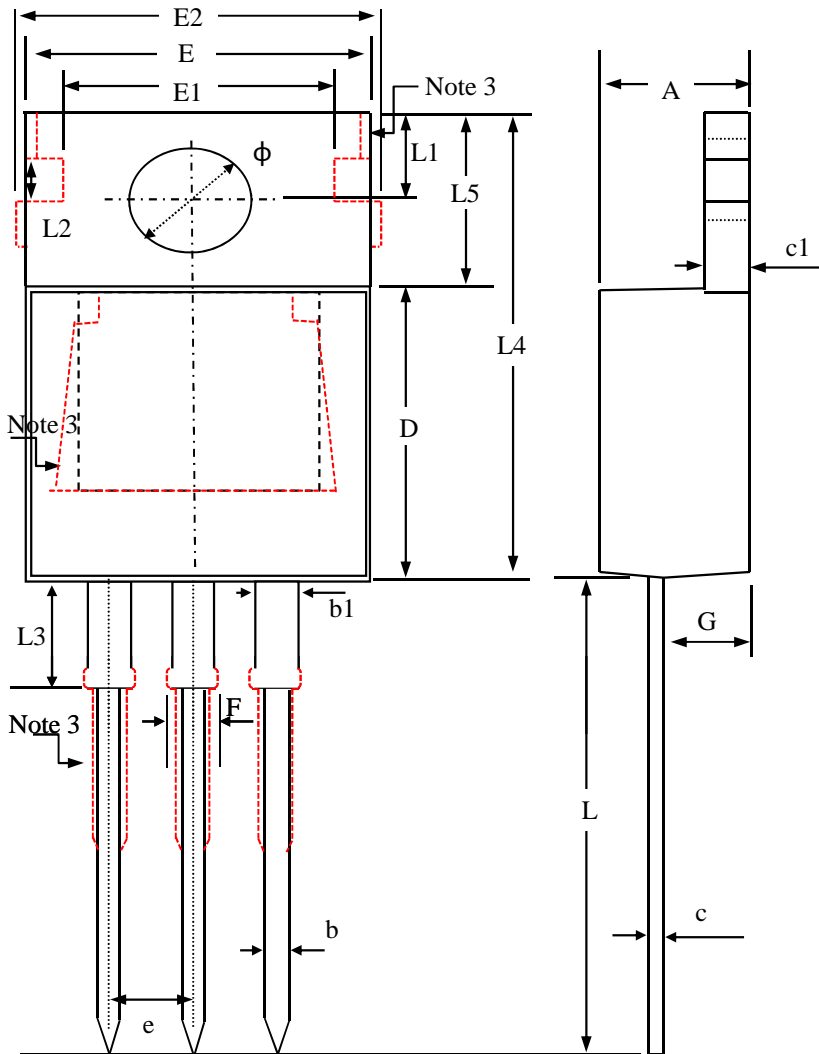

SYMBOLS	Millimeters		
	MIN	NOM	MAX
A	4.20	4.50	4.80
b	0.60	0.80	1.00
b1	1.10	1.38	1.80
c	0.30	0.48	0.65
c1	1.10	1.30	1.50
E	9.70	10.00	10.40
E1	7.40	8.30	9.20
e	2.54 (ref.)		
L	12.70	13.60	14.50
L1	2.50	2.75	3.00
L2	1.00	1.40	1.80
L3	2.60	3.35	4.10
L4	14.30	15.15	16.00
L5	6.00	6.40	6.80
ϕ	3.40	3.70	4.00
D	8.30	8.85	9.40
F	1.20	1.41	1.85
G	2.20	2.60	3.00
E2	—	—	11.50

Note:

1. All Dimensions Are in Millimeters.
2. Dimension Does Not Include Mold Protrusions.
3. Thermal PAD and Pin contour is for reference, it may has little difference by option.



TO-220 FOOTPRINT :

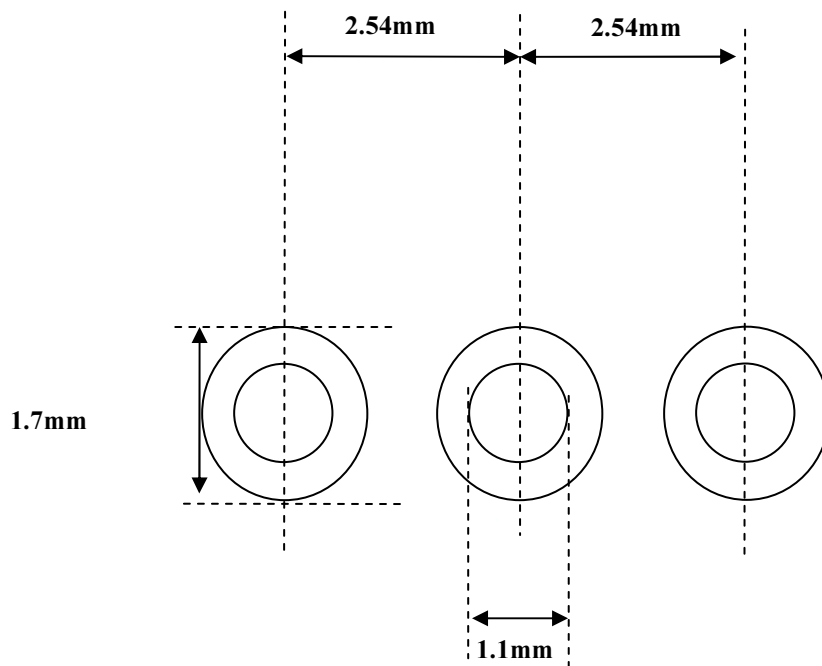

富鼎先進電子股份有限公司
包裝規範 Packing Spec

Attachment 1 : TO-220、TO-220CFM、TO-262 Carton

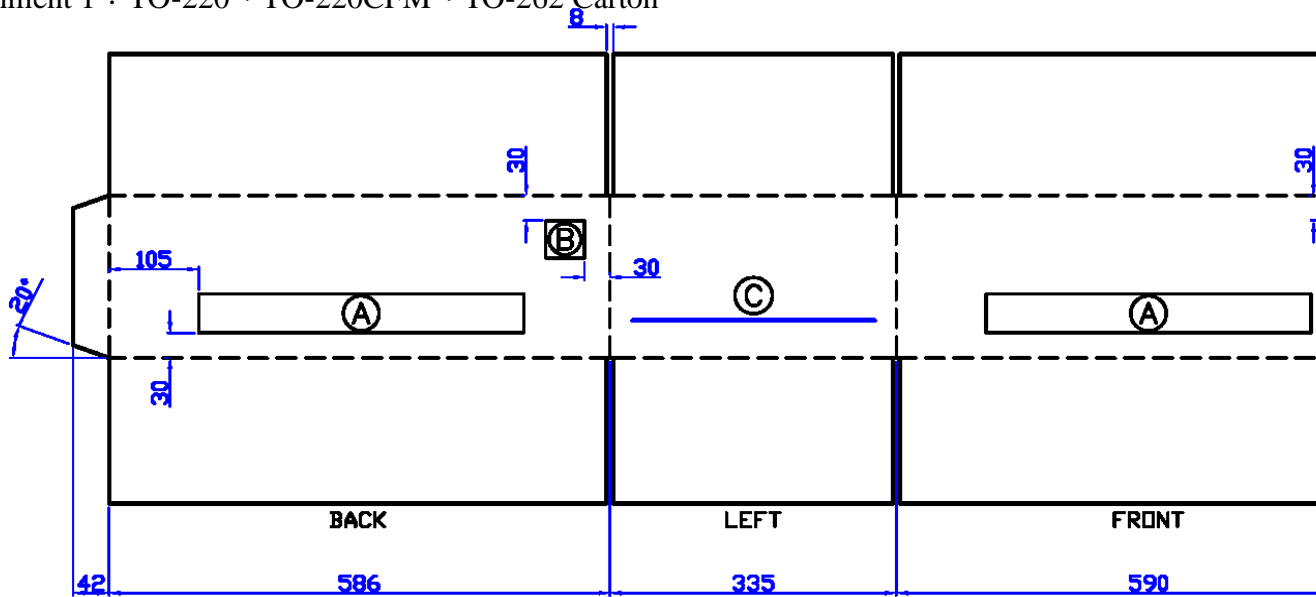

[NOTE]
1. MARKING



TOLERANCE : ±30mm

文件編號 : QWMP-7801
版 別 : 55
頁 碼 : 8

富鼎先進電子股份有限公司
ADVANCED POWER ELECTRONICS CORP.



TO-220 Material list (F)

Parts	Materila Supplier	Materila P/N	Country	Parts Weight (mg)	Hazardous Substance	Weight (mg)
Compound	Sumitomo	EMC E590HT 40mm*49g	China	630	Silica(Amorphous)	422.10
					Silica(Crystal)	63.00
					Epoxy Resin	69.30
					Metal Hydroxide	31.50
					Phenol Resin	37.80
					Carbon Black	6.30
Die attach	Heraeus	Pb93.5Sn5Ag1.5/25mil	China	4.50	Pb	4.21
					Sn	0.23
					Ag	0.07
Leadframe	Shinwon	L/F TO-220 IDF Bare(PMC 90)	Korea	1478	Copper	1475.93
					Iron	1.48
					p	0.59
Wire	Tanaka	AL WIRE (TANW)	Singapore	6.6	AL	6.5997
					Ni	0.0003
Plating	Heesung material	99.99% Tin	Korea	2.6	Sn	2.5987
					IMPURITIES	0.0013
Die	MOSEL	Wafer	Taiwan	4.08	Si	3.87
					Ag	0.11
					Al	0.06
					Ni	0.03
					Ti	0.01
					P	0.00
Other	0.01					
Total weight				2125.78		2125.780



富鼎先進電子股份有限公司

ADVANCED POWER ELECTRONICS CORP.

TO-220 Material List (HF)

Parts	Materila Supplier	Materila P/N	Country	Parts Weight (mg)	Hazardous Substance	Weight (mg)	Percentage by parts
Compound	Sumitomo	E590HT-C	China	575.000	Epoxy Resin	71.875	12.500%
					Phenol Resin	40.250	7.000%
					Silica (Amorphous) A	71.875	12.500%
					Silica (Amorphous) B	14.375	2.500%
					Silica Crystal)	373.750	65.000%
					Carbon Black	2.875	0.500%
Die Attach	Heraeus	PbSn10	China	6.500	Pb	5.850	90.000%
					Sn	0.650	10.000%
Lead Frame	SDC	LY80	China	1436.000	Cu	1434.133	99.870%
					Fe	1.436	0.100%
					P	0.431	0.030%
Plating	AISEN	99.99%Sn	China	5.000	Sn	5.000	99.992%
					Pb	0.000	0.004%
					As	0.000	0.001%
					Fe	0.000	0.001%
					Cu	0.000	0.000%
					Bi	0.000	0.002%
					Sb	0.000	0.001%
					Zn	0.000	0.000%
					Al	0.001	0.000%
Cd	0.000	0.000%					
Wire(1)	SPM	99.99%Al	Malaysia	1.500	Al	1.500	99.990%
					Other	0.000	0.010%
Wire(2)	TANAKA	99.99%Al	China	1.500	Al	1.500	99.995%
					Ni	0.000	0.005%
Die	MOSEL	Wafer	Taiwan	4.08	Si	3.87	94.769%
					Ag	0.00	2.720%
					Al	0.00	1.590%
					Ni	0.00	0.613%
					Ti	0.00	0.131%
					P	0.00	0.010%
					Other	0.00	0.167%

Total weight 2028.08

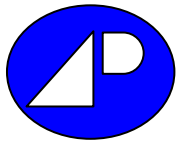

ADVANCED POWER ELECTRONICS CORP.

Recommended wave soldering profiles

The recommended solder profile for devices with Pb-free terminal plating where a Pb-free solder is used.

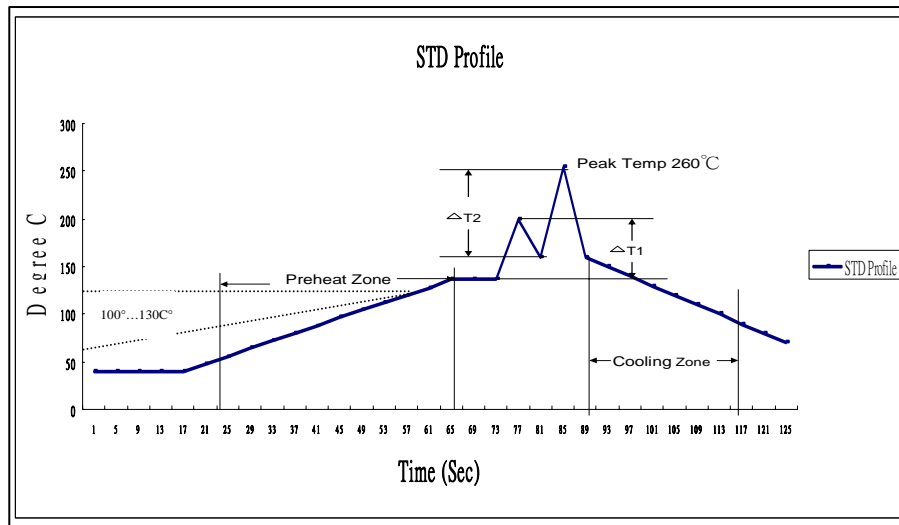

The recommended solder profile for devices with Pb-free terminal plating used with leaded solder, or for devices with leaded terminal plating used with a leaded solder.

Reflow soldering profile

- Maximum slope in preheat zone : $3^{\circ}\text{C}/\text{sec}$
- Minimum slope in cooling zone: $5^{\circ}\text{C}/\text{sec}$
- Delta T: Maximum delta T1: 100°C ; T2: 100°C
- Peak Temp 260°C .
- Time within to $+0, -5^{\circ}\text{C}$ of actual Peak: 10 Sec
- The preheat temperature : $100^{\circ}\cdots 130^{\circ}\text{C}$





Reliability Test Report

AP9579GP

- I. Accelerated Life Times Stress Test
- II. Environmental Stress Test

TO-220

Approved by	Prepared by
<i>M. D. Lin</i>	<i>S. H. Tsai</i>
Date: 2016/7/5	Date: 2016/7/5

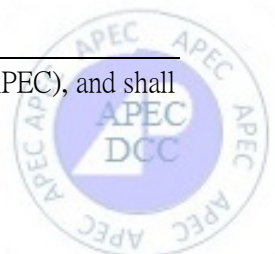

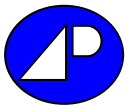
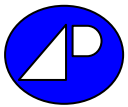

TABLE OF CONTENTS

	Page
1. Introduction	3
2. Test Procedure	3
2.1 Pre-Condition (SMD Packages devices only)	
2.2 Sampling Plan	
3. Accelerated Life Time Stress Tests	4
3.1 Test Level	
3.2 Test Result	
3.3 Test Item Description	
3.3.1 High Temperature Gate Bias (HTGB)	
3.3.2 High Temperature Reverse Bias (HTRB)	
4. Environmental & Package Stress Tests	5
4.1 Test Level	
4.2 Test Result	
4.3 Test Item Description	
4.3.1 High Temperature Storage Test (HTST)	
4.3.2 High Temperature & Humidity Reverse Bias (H3TRB)	
4.3.3 Temperature Humidity Storage Test (THST)	
4.3.4 Power Cycling Test (PRCL)	
4.3.5 Temperature Cycling Test (TCT)	
4.3.6 Pressure Cooker Test (PCT)	
4.3.7 Highly Accelerated Stress Test (HAST)	





1. Introduction

This report records the APEC product reliability test procedure, items and results; give a clear overview of reliability qualification test.

2. Test Procedure

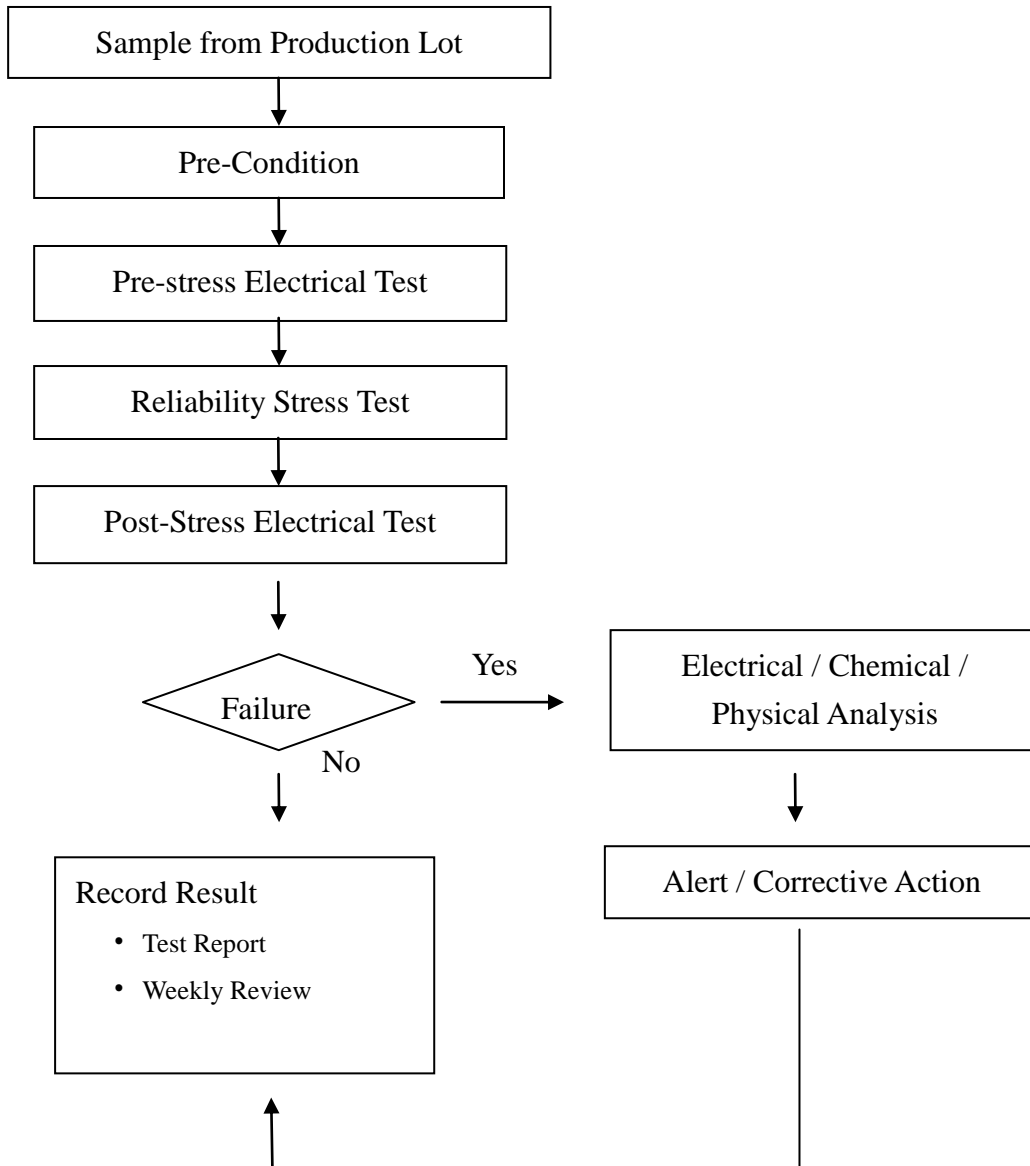

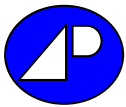

2.1 Pre-Condition (SMD Packages devices only)

This is to simulate the product storage, shipping and customer application environment.

Step 1: Baking 125°C , 24hrs.

Step 2: 85°C / 85%R.H. Soaking 168hrs. (J-STD-020 Level 1)

Step 3: IR Reflow Tmax.= 260°C , 3cycles

2.2 Sampling plan

Based on LTPD = 10% , AC=0

3. Accelerated Life Time Stress Test

3.1 Test Level

- Routine Monitor Qualification
- New Product Qualification
- Engineer / Customer Request Qualification

3.2 Test Result

Test Item	Sample Size	Total Device (hours)	Result	Failure Rate (FITs)	MTTF' (10 ⁶) Devices hrs.
High Temperature Gate Bias(HTGB)	77	77000 hrs	Pass	338.88	2.95
High Temperature Reverse Bias (HTRB)	77	77000 hrs	Pass	338.88	2.95

CL = 90% ; Ea = 0.7eV ; Operating Temp. = 70°C

3.3 Test Item Description

3.3.1 High Temperature Gate Bias (HTGB)

- Reference Standard
EIAJ ED-4701 D323
HTGB Operation spec. (QWRAD-7117)
- Condition:
Temperature: Max. Operating Temperature
Test Point: 0, 168, 500, 1000 Hours Nominal



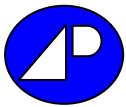

Bias: Max. VGS Rating

3.3.2 High Temperature Reverse Bias (HTRB)

- Reference Standard

EIAJ ED-4701 D321

HTRB Operation spec. (QWRAD-7118)

- Condition:

Temperature: Max. Operating Temperature

Test Point: 0, 168, 500, 1000 Hours Nominal

Bias: VS=VG=0V, VD= 80% of Max. BVDSS Rating

4. Environmental & Package Stress Test

4.1 Test Level

- Routine Monitor Qualification
- New Product Qualification
- Engineer / Customer Request Qualification

4.2 Test Result

Test Item	Sample Size	Test Time (hours/ cycles)	Result
HTST	77	1000 hrs.	Pass
H3TRB	77	1000 hrs.	Pass
THST	77	1000 hrs.	Pass
PRCL	77	15K cyc.	Pass
TCT	77	1000 cyc.	Pass
PCT	77	168 hrs.	Pass
HAST	77	96 hrs.	Pass

The pre-conditioning (SMD Packages devices only)

4.3 Test Item Description

4.3.1 High Temperature Storage Test (HTST)

- Reference Standard

EIAJ ED-4701 B111A

HTST Operation spec. (QWRAD-7116)



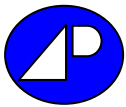

- Condition:
Temperature: 150°C
Test Point: 0, 1000 Hours Nominal
Bias: no Bias

4.3.2 High Temperature & Humidity Reverse Bias (H3TRB)

- Reference Standard
EIAJ ED-4701 B122A
H3TRB Operation spec. (QWRAD-7111)
- Condition:
Temperature: 85°C
Relative Humidity: 85% R.H.
Test Point: 0, 168, 500, 1000 Hours Nominal
Bias: VS=VG=0V,
VD= 80% of Max. BVDSS Rating up to 100V

4.3.3 Temperature Humidity Storage Test (THST)

- Reference Standard
EIAJ ED-4701 B121
THST Operation spec. (QWRAD-7115)
- Condition:
Temperature: 85°C
Relative Humidity: 85% R.H.
Test Point: 0, 1000 Hours Nominal
Bias: no bias

4.3.4 Power Cycling Test (PRCL)

- Reference Standard
EIAJ ED-4701 D322
PRCL Operation spec. (QWRAD-7114)
- Condition:
Temperature: Ta=25°C Tj=Δ100°C Ton=2 Minute, Toff=2 Minute
Test Point: 0, 10K, 15K Cycles Nominal
Bias (Set to give) : ΔT=100°C



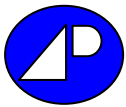

4.3.5 Temperature Cycling Test (TCT)

- Reference Standard

JESD22-A104

TCT Operation spec. (QWRAD-7113)

- Condition:

Temperature: $T_{min.} = -55^{\circ}\text{C}$, $T_{max.} = 150^{\circ}\text{C}$, $\Delta T = 205^{\circ}\text{C}$

Test Point: 0, 1000 cycles Nominal

4.3.6 Pressure Cooker Test (PCT)

- Reference Standard

JESD22-A102C

PCT Operation spec. (QWRAD-7110)

- Condition:

Temperature: 121°C

Relative Humidity: 100% R.H.

Pressure: 2 atm

Test Point: 0, 168 Hours Nominal

4.3.7 Highly Accelerated Stress Test (HAST)

- Reference Standard

JESD22-A118

- Condition:

Temperature: 130°C

Relative Humidity: 85% R.H.

Pressure: 33.3 psia / 230kPa

Test Point: 0, 96 Hours Nominal





AP9579GP

Electrostatic Discharge Test

Test Result

Test Item	Passed Voltage	Sensitivity Classification
HBM	1800V	Class 1C
MM	400V	Class C
CDM	1000V	Class C3

Test Item Description

1 Human Body Model (HBM)

- Reference Standard
MIL-STD-883 Method 3015.7
- Condition:
C = 100pF, R = 1500Ω

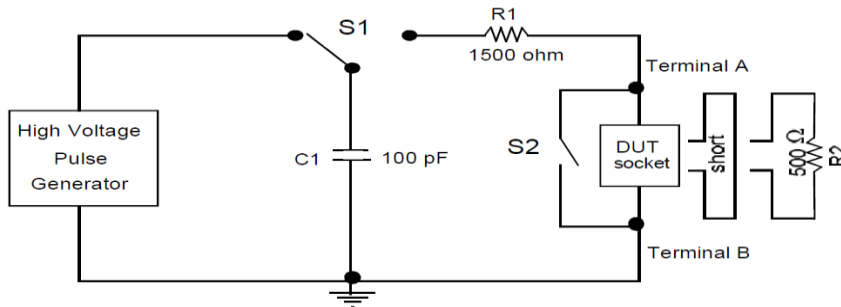

2 Machine Mode (MM)

- Reference Standard
JEDEC EIA/JESD22-A115
- Condition:
C = 200pF, R = 0Ω

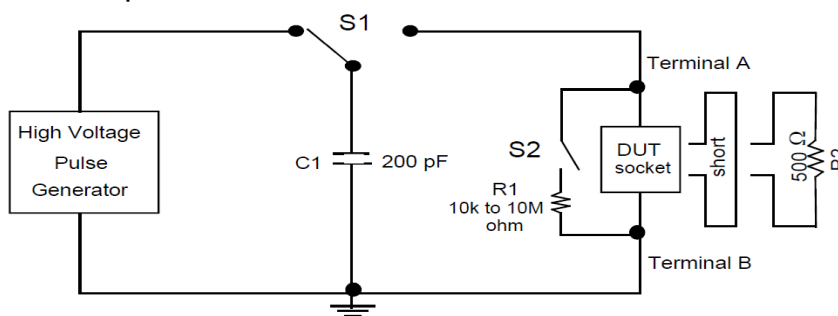

3 Charged Device Model (CDM)

- Reference Standar
JESD22-C101F
R = 100MΩ

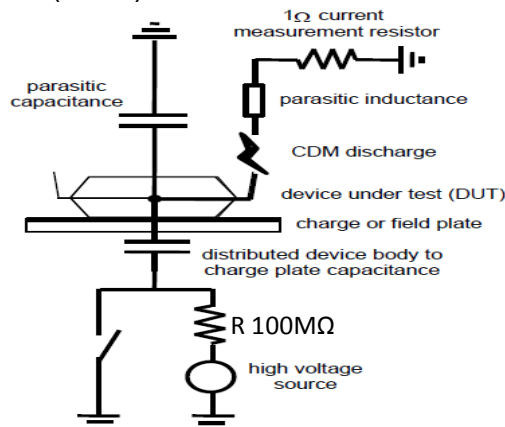

X-ON Electronics

Largest Supplier of Electrical and Electronic Components

Click to view similar products for [MOSFET](#) category:

Click to view products by [APEC](#) manufacturer:

Other Similar products are found below :

[614233C](#) [648584F](#) [MCH3443-TL-E](#) [MCH6422-TL-E](#) [FDPF9N50NZ](#) [FW216A-TL-2W](#) [FW231A-TL-E](#) [APT5010JVR](#) [NTNS3A92PZT5G](#)
[IRF100S201](#) [JANTX2N5237](#) [2SK2464-TL-E](#) [2SK3818-DL-E](#) [FCA20N60_F109](#) [FDZ595PZ](#) [STD6600NT4G](#) [FSS804-TL-E](#) [2SJ277-DL-E](#)
[2SK1691-DL-E](#) [2SK2545\(Q,T\)](#) [D2294UK](#) [405094E](#) [423220D](#) [MCH6646-TL-E](#) [TPCC8103,L1Q\(CM](#) [367-8430-0972-503](#) [VN1206L](#)
[424134F](#) [026935X](#) [051075F](#) [SBVS138LT1G](#) [614234A](#) [715780A](#) [NTNS3166NZT5G](#) [751625C](#) [873612G](#) [IRF7380TRHR](#)
[IPS70R2K0CEAKMA1](#) [RJK60S3DPP-E0#T2](#) [RJK60S5DPK-M0#T0](#) [APT5010JVFR](#) [APT12031JFLL](#) [APT12040JVR](#) [DMN3404LQ-7](#)
[NTE6400](#) [JANTX2N6796U](#) [JANTX2N6784U](#) [JANTXV2N5416U4](#) [SQM110N05-06L-GE3](#) [SIHF35N60E-GE3](#)