

Dualmec™ 6C

2-pole tactile switch •
low profile • IP67

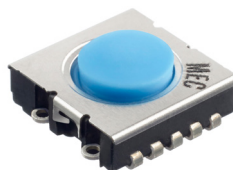

DISTINCTIVE FEATURES

- 2-pole contact (DPST)
- Low profile h=3.5 mm
- 8 x 8 mm
- Sealed to IP67
- 1,000,000 cycles lifetime



ENVIRONMENTAL SPECIFICATIONS

- Sealing : IP67 according to IEC 60529
- Working and storage temperature : -40 °C/+85 °C (-40 °F to 185°F)
- Soldering : JEDEC J-STD-020E



ELECTRICAL SPECIFICATIONS

- Recommended load : 0.5-50 mA 24 VDC
- Contact resistance : <50 mΩ
- Insulation resistance : >10 MΩ
- Contact bounce : <2 mS
- Dielectric strength: 250 V



MECHANICAL SPECIFICATIONS

- Standard actuation force : 2.5 N ±1.0 N
- Max. actuation force : 100 N for 10 sec
- Travel : 0.3 mm ±0.15 mm
- Lifetime : 1,000,000 cycles
- B10D : 1,000,000 cycles

The company reserves the right to change specifications without notice.



MATERIALS

- Housing : PPS UL94V0
- Actuator : silicone
- Contact domes : stainless steel 3μAg
- Fixed contacts :
CuZn + 1 μNi + 4 μAg
- Terminals : CuZn + 1 μNi

All tolerance if not otherwise specified ±0.2mm.

Dualmec™ 6C

2-pole tactile switches •
low profile • IP67

6CJ2NOP

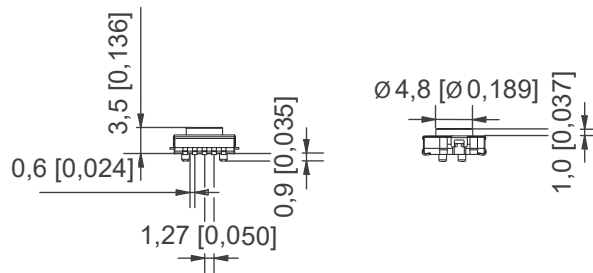
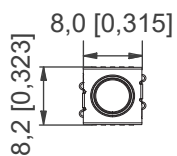

- J-bend
- NO
- 2-pole

All tolerances unless otherwise noted : ±0.2 mm



PCB LAYOUT & CIRCUIT DIAGRAM

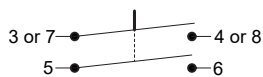
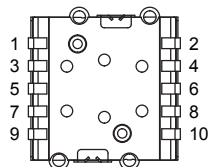
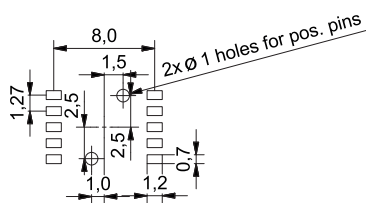

Dualmec™ 6C

2-pole tactile switches •
low profile • IP67



BUILD YOUR PART NUMBER

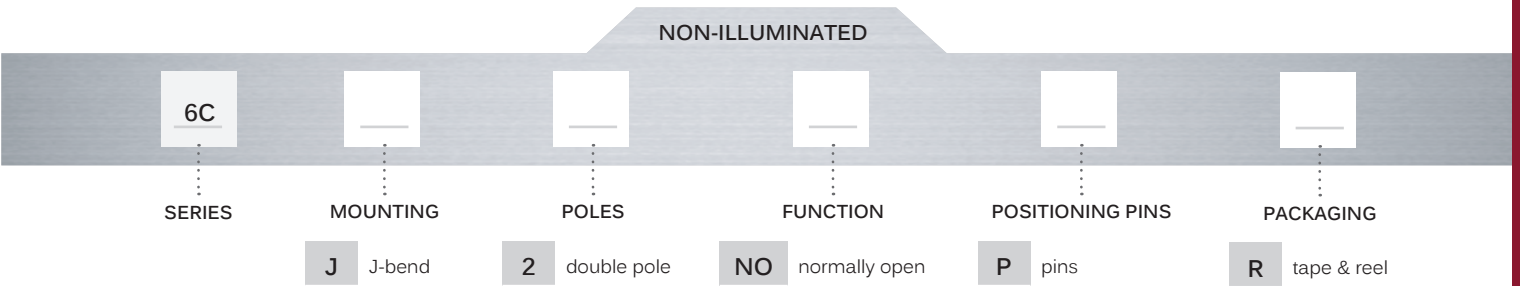

ABOUT THIS SERIES



Accessories : See APEM website for cap options

Dualmec™ 6C

2-pole tactile switches •
low profile • IP67



TAPE & REEL

Tape and reel is available for the parts listed and has the following specifications

- Reel diameter: Ø330 mm
- Tape width: 16 mm
- Pitch: see list
- Tape and reel material : antistatic or better
- Quantity per reel : see list

PART NO.	ORDERING CODE	PITCH	QUANTITY PER REEL
6CJ2NOP	6CJ2NOPR	12	500

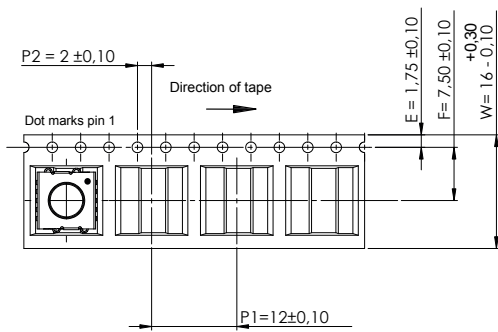

MOUNTING

SPACE REQUIREMENT - MATRIX MOUNTING

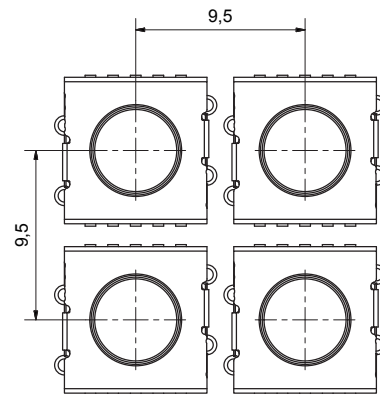

surface mount (J-bend)



USAGE GUIDELINES

HOW TO GET THE BEST RESULTS WITH MEC SWITCHES ?

These guidelines are offered to users of MEC Switches as an aid to ensure successful and reliable switch operation. Please see the technical specifications for details on operating and storage temperatures and soldering guidelines to make sure you select the best switch for your application.

When reflow soldering is taking place, MEC strongly recommend that the temperature profile is analyzed and compared with the temperature rating of the switch. It is also important to monitor the accumulated heat buildup from both the pre-heat zones and the solder zone.

Standard accessories for Dualmec™ 6 series switches are made from ABS plastic with a maximum operating temperature of 65 °C.

MOUNTING AND DISMOUNTING

If switches are to be mounted in rows, it is essential that the recommendations regarding spacing are followed. PC board thickness should be 1.4 ±0.2 mm.

SOLDERING AND CLEANING ULTRAMEC™ SERIES

Dualmec™ series switches are fully sealed to IP67 specifications to minimize solder flux and aqueous based cleaning solutions from entering the switch and contaminating the contacts. The switches can be placed on the PC board with other components and reflow soldered. Dualmec™ series offers a high level of sealing, however, with aqueous solvent solutions care must be taken to avoid the worst case situation with water jets, complete immersion into a liquid with a temperature below the board or surface tension reducing additives.

Recommended cleaning methods are demineralized water. Any surface tension reducing agents, such as soap, must not be used as they risk causing a potential leakage of the switch.

SOLDERING - SURFACE MOUNT VERSIONS

For all methods - infrared, convection and vapor phase. The upper limit 240 °C/40 sec must be observed. The soldering temperature profile must have moderate temperature gradients. (JEDEC J-STD-020E)

ROHS COMPLIANCE

As of 1 July 2006 MEC has completed the conversion to RoHS compliance. For more info please see our homepage www.apem.com

TEMPERATURE LIMITS:

Switch	85 °C
Accessories	65 °C

PACKAGING

Dualmec™ series switches are delivered on tape/reel. Each reel contains 500 pcs. It is also possible to purchase half full reels.

X-ON Electronics

Largest Supplier of Electrical and Electronic Components

Click to view similar products for [Tactile Switches](#) category:

Click to view products by [Apem](#) manufacturer:

Other Similar products are found below :

[6407-250V-25273P](#) [ADTSA62NV](#) [B3F-3123](#) [1977177-8](#) [1977266-1](#) [ADTSA63NV](#) [ADTSM21NSVTR](#) [ADTSM25RVTR](#) [ADTSM32NVTR](#)
[ADTSMW64RV](#) [1977120-6](#) [FSMRA4JHA04](#) [GS4.70F300QP](#) [KSC241J](#) [SP DELTA LFS](#) [3FTL600RAS](#) [3FTL640RAS](#) [Y96K132V0FPLFS](#)
[09158](#) [6407-250V-25343P](#) [ADTSM31NVTR](#) [2-1977120-7](#) [TSJW-5.2-260-TR](#) [TME1-01-Z](#) [Y651050400P](#) [KMT011MNGJLHS](#)
[ADTSG648NV](#) [ADTSM62KSVTR](#) [MJTP1138DTR](#) [ADTSM648NV](#) [95C06E3RAT](#) [3ATH9Q](#) [FSMRA8JHA04](#) [HARS0073](#)
[Y33R411N9FPLFT](#) [Y33R51139FPLFT](#) [Y31C01402FPLFS](#) [PTS645SK50SMTR92](#) [ADTSM32NVB](#) [KMS233GPWTFLG](#) [Y78B64124FP](#)
[Y33A812C5FP LFT](#) [Y56B2D120FP LFS](#) [PTS645 DVM83-BN125-2 LFS](#) [B3W 1000G](#) [B3F 1002C](#) [B3F 0047H](#) [B3W 1002C](#) [B3F 5001G](#)
[B3W 1100C](#) [1-1571563-4](#)