

# HF series

Proportional multi-axis fingertip controllers •  
non-contacting Hall effect technology



## DISTINCTIVE FEATURES

One, two or three axis

Analog outputs

CAN bus J1939 and CANopen options

USB 2.0 HID interface options

Connectorized housing



## ENVIRONMENTAL SPECIFICATIONS

- Operating Temperature: -40 °C to +85 °C (-40 °F to +185 °F)
- Storage Temperature: -40 °C to +85 °C (-40 °F to +185 °F)
- Above Panel Sealing: Up to IP67 (subject to final specifications)
- EMC Immunity Level (V/M): EN61000-4-3
- EMC Emissions Level: EN61000-6-3:2001
- ESD: EN61000-4-2
- Output linearity:  $\pm 200$  mV
- Dual output interlinearity (X/Y):  $\pm 400$  mV
- Dual output interlinearity (Z):  $\pm 600$  mV



## SENSOR SPECIFICATIONS

- Sensor: Hall effect, single or dual
- Supply Voltage Range: 5 VDC  $\pm 0.01$  VDC
- Supply Current: 40 mA typical / 50 mA max (3 axis)
- Reverse Polarity Max: -10 VDC
- Transient Overvoltage Max: 16 VDC
- Ratiometric Output Voltage: see output options
- Output Current: 8 mA
- Output Load: 1 K ohm min
- Output Impedance: 2  $\Omega$



## MATERIALS

- Shaft: Stainless Steel
- Boot: Silicone
- Handles: Glass filled nylon\*
- Body: Glass filled nylon

The company reserves the right to change specifications without notice.



# HF series

Proportional multi-axis fingertip controllers • non-contacting Hall effect technology



## MECHANICAL SPECIFICATIONS (X/Y AXIS)

- Break Out Force: 1.3N (0.3lbf)
- Operating Force: 2.8N (0.63lbf)
- Maximum Applied Force: 350N (78.00lbf)
- Deflection Angle: 36° (±18° from center)
- Expected Mechanical Life: 5 million lifecycles
- Lever Action: Single spring, omnidirectional



## MECHANICAL SPECIFICATIONS (Z AXIS)

- Break Out Torque: 0.09Nm (0.80lbf in)
- Operating Torque: 0.121Nm (1.07lbf in)
- Maximum Allowable Torque: 9.0Nm (80lbf in)
- Degrees of rotation: 60° (30° from center)
- Expected Mechanical Life: 5 million lifecycles
- Handle Action: Spring centering



## TERMINATION (ANALOG OUTPUTS ONLY)

- The HF series (Output options AA-HH **only**) features a **Hirose DF11-12DP-2DS9 (24)** header (male receptacle) (Fig 1)
- The mating wire harness is not included but may be selected from the BUILD YOUR PART NUMBER option selection guide. This optional harness features a **Hirose DF11-12DS-2C** connector (female socket) (Fig 2) to individual stripped and tinned wire leads
- Header specifications: 12 position, 2mm pitch dual row (2x6) pin header
- Wire harness specifications: 22AWG Teflon, 25cm multi-conductor with heat shrink. Hirose **DF11-12DS-2C** to individual stripped and tinned wire leads

Fig. 1

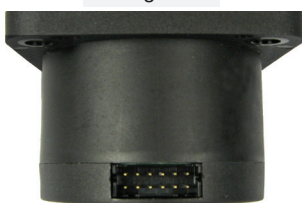

Hirose DF11-12DP-2DS9(24) header

Fig. 2

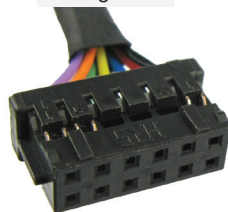

Mating wire harness fitted with Hirose DF11-12DS-2C connector

### JOYSTICK HEADER - HIROSE DF11-12DP-2DS9 (24) PINOUT (Fig 1)

PIN 2	PIN 4	PIN 6	PIN 8	PIN 10	PIN 12
RED	BLUE	YELLOW	GREEN	WHITE	--
BLACK	BLU/WHT	YEL/BLK	GRN/BLK	ORANGE	VIOLET
PIN 1	PIN 3	PIN 5	PIN 7	PIN 9	PIN 11

### MATING WIRE HARNESS COLOR DEFINITION (Fig 2)

HIROSE DF11-12DS-2C CONNECTOR PIN #	WIRE COLOR	JOYSTICK FUNCTION
1	Black	Ground
2	Red	Supply power
3	Blue / white	X axis (dual output)
4	Blue	X axis
5	Yellow / black	Y axis (dual output)
6	Yellow	Y axis
7	Green / black	Z axis (dual output)
8	Green	Z axis
9	Orange	Button one
10	White	Button common
11	Violet	Button two
12	--	--

\* Most handles, dependent upon configurations

Proportional multi-axis fingertip controllers • non-contacting Hall effect technology



## GENERAL MOUNTING OPTIONS

DROP-IN MOUNT

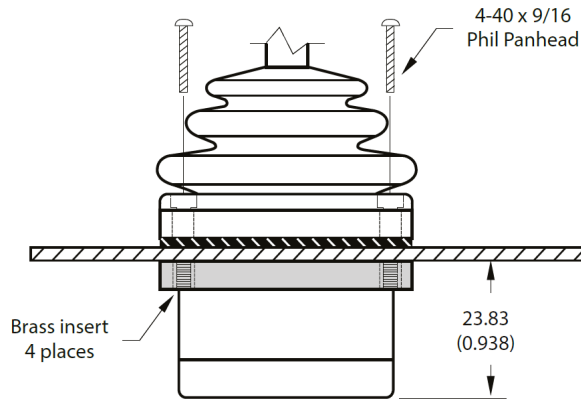

REAR MOUNT

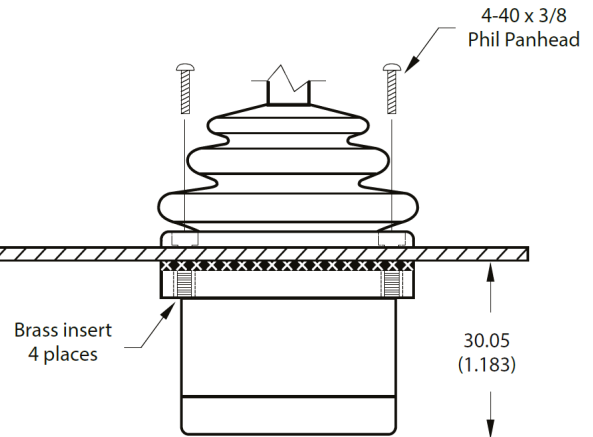

## PANEL CUT-OUT

DROP-IN MOUNT

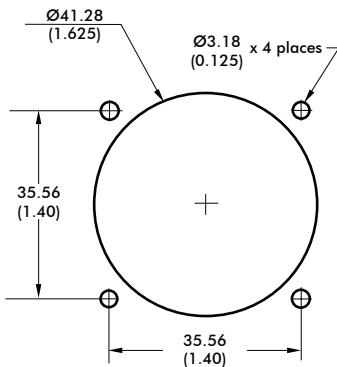

REAR MOUNT

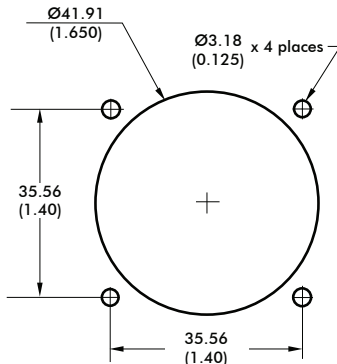

Not available for option 55 handles

CLAMPING RING

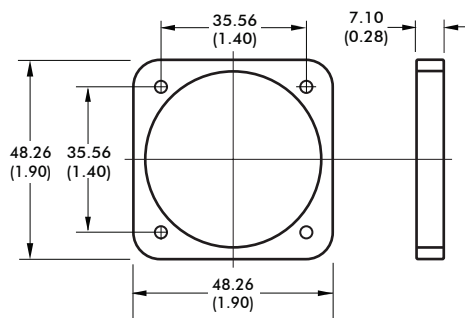

AXIS ORIENTATION

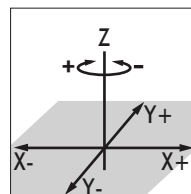

NOTES:

- For DROP-IN mounting, panel thickness can be 1.17 mm to 3.17 mm (0.046 in to 0.125 in).
- For REAR MOUNT, the maximum panel thickness is 1.6 mm (0.063 in).
- A panel thickness of 1/16" (1.6 mm/0.063 in) was considered for all below panel depth values.
- The below panel depth is extended by 7.11 mm (0.28 in) with the USB, Cursor Emulation, Voltage Regulator options.

# HF series

Proportional multi-axis fingertip controllers • non-contacting Hall effect technology



## CAN J1939 INTERFACE SPECIFICATION

The HF Series joystick can be configured with a maximum of three axis and two buttons. All axis and button data are delivered on a CAN 2.0B compliant physical interface. Two additional signals allow configuration of the controller Source Address. Controller messages are delivered per the SAE J1939-71 message protocol.

### CAN 2.0B INTERFACE PARAMETERS

- Baud rate: 250 Kbps
- Transmission repetition rate: 50ms
- BJMI/EJMI interval time: 20ms
- Terminating resistor: No (available by special request to factory)

### CAN MESSAGE PROTOCOL

- Primary Axis and button data on Basic Joystick Message 1 (BJM1):
  - Priority: 3
  - Base PGN: 0xFDD6
  - Source address: 0x13
  - Data field: 8 bytes
- Redundant Axis data on Extended Joystick Message 1 (EJMI):
  - Priority: 3
  - Base PGN: 0xFDD7
  - Source address: 0x13
  - Data field: 8 bytes

### CAN SOURCE ADDRESSES

Alternate source addresses may be selected by grounding combinations of the blue and/or orange wires. For further information, please see TERMINATION on page 6.

CAN SOURCE ADDRESS	ORANGE WIRE	BLUE WIRE
0x13 (default)	OPEN	OPEN
0x23	OPEN	Grounded
0x33	Grounded	OPEN
0x43	Grounded	Grounded

### BJM1 DATA FIELD STRUCTURE:

START POSITION (BYTE/BIT)	LENGTH (BITS)	FUNCTION
1/1	2	Primary X-axis neutral position status
1/3	2	Primary X-axis left position status
1/5	2	Primary X-axis right position status
1/7 to 2/8	10	Primary X-axis position data
3/1	2	Primary Y-axis neutral position status
3/3	2	Primary Y-axis down position status
3/5	2	Primary Y-axis up position status
3/7 to 4/8	10	Primary Y-axis position data
6/5	2	Button 2 status
6/7	2	Button 1 status

### EJMI DATA FIELD STRUCTURE:

START POSITION (BYTE/BIT)	LENGTH (BITS)	FUNCTION
1/1	2	Redundant X-axis neutral position status
1/3	2	Redundant X-axis left position status
1/5	2	Redundant X-axis right position status
1/7 to 2/8	10	Redundant X-axis position data
3/1	2	Redundant Y-axis neutral position status
3/3	2	Redundant Y-axis down position status
3/5	2	Redundant Y-axis up position status
3/7 to 4/8	10	Redundant Y-axis position data
5/1	2	Primary Z-axis neutral position status
5/3	2	Primary Z-axis counter-clockwise position status
5/5	2	Primary Z-axis clockwise position status
5/7 TO 4/8	10	Primary Z-axis position data

### CUSTOM CAN BUS J1939 FIRMWARE\*

- Baud rate: 125 Kbps, 500Kbps, 1Mbps (250 Kbps default)
- Custom CAN addresses
- Custom CAN bus output

\* Custom CAN bus firmware available upon request.

Proportional multi-axis fingertip controllers • non-contacting Hall effect technology



## CANOPEN INTERFACE SPECIFICATION

### CANOPEN INTERFACE PARAMETERS\*

- Baud rate: 250 Kbps
- Node ID: 20h
- Buttons: 1A0H (180H + NODE ID)
- Analog (axis) outputs: 2A0h (280h + Node ID)
- Heartbeat (500ms): 720h (700h + Node ID)
- Axis resolution: 8 bit
- Network Management: Auto start enabled

### CANOPEN NODE ID SELECTION

Alternate NODE IDs may be selected by grounding the blue and/or orange wires. For further information, please see TERMINATION on page 6.

NODE ID SELECT	ORANGE WIRE	BLUE WIRE
20H (default)	OPEN	OPEN
21H	OPEN	Grounded
22H	Grounded	OPEN
23H	Grounded	Grounded

### CANOPEN BUTTON OUTPUT CONFIGURATION

Button status is transmitted in the one byte data field of frames with an identifier of 1A0 (default)	
Identifier	Byte 0
1A0	Buttons (2:0)

### CANOPEN ANALOG OUTPUT CONFIGURATION

Eight bit analog data is transmitted in the three byte data field of frames with an identifier of 2A0 (default)			
Identifier	Byte 0	Byte 1	Byte 2
2A0	A_IN0 (7:0)	A_IN1 (7:0)	A_IN2 (7:0)

### CUSTOM CANOPEN FIRMWARE\*

- Baud rate: 125 Kbps, 500Kbps, 1Mbps (250 Kbps default)
- Custom Node IDs (default 20 hexadecimal)
- 10-bit axis resolution
- 12-bit axis resolution
- Signed resolution
- Custom CANopen output



## CANOPEN LSS INTERFACE SPECIFICATION

The CANopen LSS interface option follows the CiA305 and CiA401 standards for CAN in automation. The node ID, baud rate and additional configurations can be set and stored in the EEPROM by Service Data Object. The default settings are as follows:



## CANOPEN LSS INTERFACE SPECIFICATION

### CANOPEN INTERFACE PARAMETERS\*

- Baud rate: 250 Kbps
- Node ID: 20h (default)
- Buttons: 1A0H (180H + NODE ID)
- Analog (axis) outputs: 2A0h (280h + Node ID)
- Heartbeat (500ms): 720h (700h + Node ID)
- Axis resolution: 10-bit
- Network Management: Auto start enabled

### CANOPEN LSS BUTTON OUTPUT CONFIGURATION

Button status is transmitted in the one byte data field of frames with an identifier of 1A0 (default)	
Identifier	Byte 0
1A0	Buttons (2:0)

### CANOPEN LSS ANALOG OUTPUT CONFIGURATION

Ten bit analog data is transmitted in the six byte data field of frames with an identifier of 2A0 (default)			
Identifier	Byte 0	Byte 1	Byte 2
2A0	A_IN0 (7:0)	A_IN0 (9:8)	A_IN1 (7:0)
Identifier	Byte 3	Byte 4	Byte 5
2A0	A_IN1 (9:8)	A_IN2 (7:0)	A_IN2 (9:8)

\* Custom CAN bus firmware available upon request.

# HF series

Proportional multi-axis fingertip controllers • non-contacting Hall effect technology



## TERMINATION (CAN OUTPUTS ONLY)

- HF series joysticks configured with CAN outputs (Output options NN-QQ **only**) feature a **JST B6B-PH-S(LF)(SN)** header (male receptacle) (Fig 1) and are supplied with a mating wire harness (Fig 2)
- Header specifications: JST B6B-PH-S(LF)(SN) - 6 position, 2mm pitch, single row header (Fig 1)
- Mating wire harness specifications: Six conductor, 22AWG, 56cm PTFE, JST PHR-6 to stripped and tinned wire leads (Fig 2)

Fig. 1

Fig. 2



### HEADER PINOUT AND MATING WIRE HARNESS COLOR DEFINITION

HEADER PINOUT			MATING WIRE HARNESS
JST B6B-PH-S(LF)(SN) HEADER PIN #	CAN bus FUNCTION	CANopen FUNCTION	WIRE COLOR
1	Supply power	Supply power	Red
2	Ground	Ground	Black
3	ID select MSB	Node ID select MSB	Orange
4	ID select LSB	Node ID select LSB	Blue
5	CAN Hi	CAN Hi	Green
6	CAN Lo	CAN Lo	White

\* Custom CAN bus firmware available upon request.

Proportional multi-axis fingertip controllers • non-contacting Hall effect technology



## CANOPEN LSS INTERFACE SPECIFICATIONS

The CANopen LSS interface option follows the CiA305 and CiA401 standards for CAN in automation. The node ID, baud rate and additional configurations can be set and stored in the EEPROM by Service Data Object. The default settings are as follows:

SETTINGS	DEFAULT CONFIGURATION
Baud rate	250 kbits/s
Node ID	20h
Analog (axis) outputs	2A0h (280h + Node ID)
Buttons	1A0h (180h + Node ID)
Heartbeat (500ms)	720h (700h + Node ID)
Axis Resolution	Unsigned 10-bit



## CAN BUS SPECIFICATIONS

### DIMENSIONS

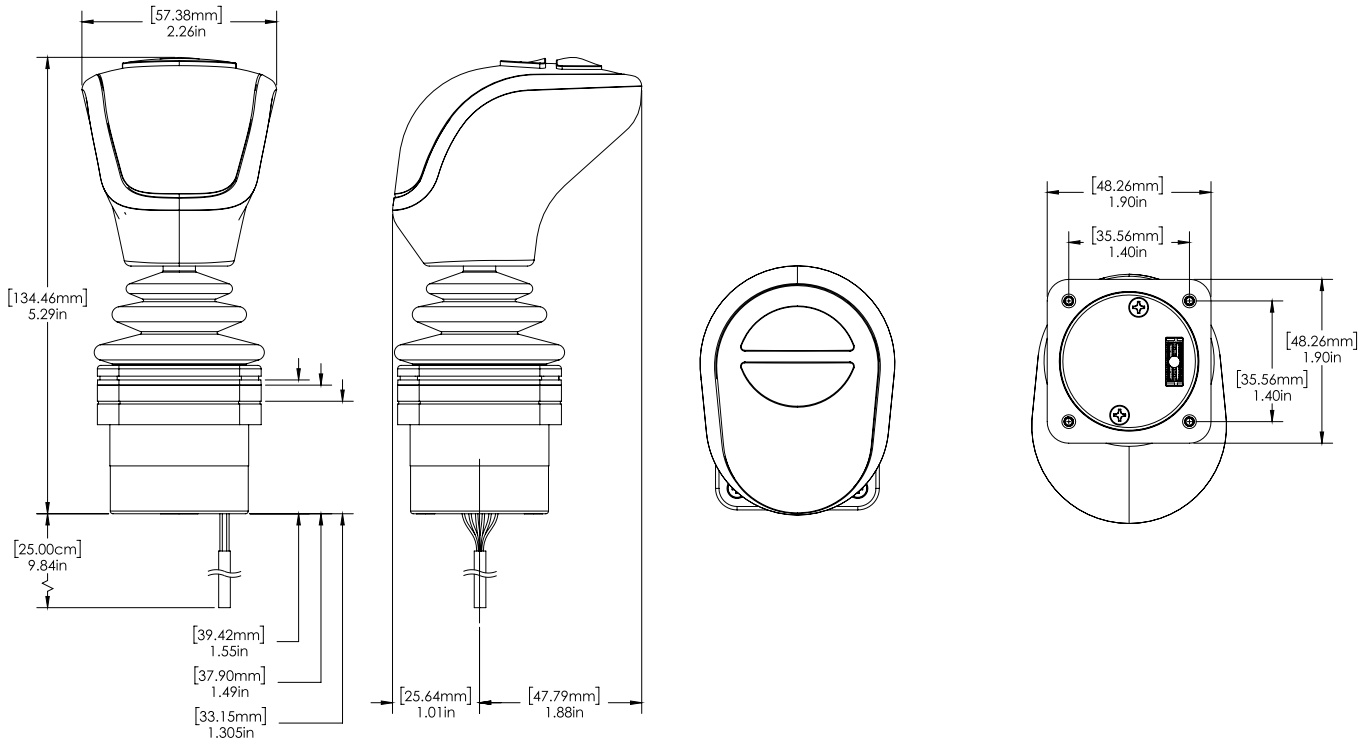

# HF series

Proportional multi-axis fingertip controllers • non-contacting Hall effect technology



## USB SPECIFICATIONS

- Supply Voltage Range: 5.00VDC
- Maximum current: 70mA
- USB version: 2.0

### USB GAME CONTROLLER

Featuring USB 2.0 HID compliant interface, APEM's USB joysticks are recognized as standard HID "game controller" devices. Adhering to the HID specification, APEM's USB joysticks are plug-and-play with most versions of Windows. Joystick button and axis assignments are dependent upon the controlled application.

#### Features

- USB 2.0 HID compliant "game controller" device
- Easy to install and operate
- Functions determined by controlled application
- 12-bit (0 to 4095) axis resolution

#### Termination (supplied cable)

- USB Male Type A Connector (198 cm)

### USB CURSOR EMULATION

The Cursor Emulation option converts multi-axis joystick output into a mouse or cursor control device. The Cursor Emulation option is ideal for vehicle applications subjected to dirt and high vibration which makes operating a traditional cursor control device difficult. Cursor simulation is only compatible with Window OS.

#### Features

- HID compliant "mouse" device

#### Button Function

- B1: Left Mouse Click
- B2: Right Mouse Click

#### Termination (supplied cable)

- USB Male Type A Connector (198 cm)



## VOLTAGE REGULATOR SPECIFICATIONS

The Voltage Regulator allows APEM's Hall effect joysticks to operate with a range of supply voltages..

### Voltage Regulator - Unipolar

- Supply Voltage Range: 8-35VDC
- Output Voltage Range: see output options
- Maximum Current: 90mA

### SUPPORTED OPERATING SYSTEMS: USB GAME CONTROLLER AND CURSOR EMULATION

#### Windows Operating System

- Windows 7
- Windows 8.1
- Windows 10

#### Linux Operating System

APEM's USB joysticks are compatible with Linux, although system compatibility is not guaranteed. The user is responsible for verifying specific Linux OS compatibility.

#### Custom Firmware

Custom configurations and firmware is available upon request. Available options include:

- 8-bit axis resolution
- 10-bit axis resolution
- Signed bit axis resolution
- Custom USB product name

#### Voltage Regulator - Bipolar

- Supply Voltage Range: 11-35VDC
- Output Voltage Range:  $\pm 10$ VDC
- Maximum Current: 90mA

#### Termination (supplied cable)

- 28 AWG 16.5cm  $\pm 1.25$ cm PTFE



Proportional multi-axis fingertip controllers • non-contacting Hall effect technology



## BUILD YOUR PART NUMBER



SERIES

HANDLE

10	Ball tip (2 axis)
11	Tapered (2 axis)
22	1 Pushbutton (2 axis)
27	1 Pushbutton (2 axis), IP67 sealed
33	3 Axis
44	1 Pushbutton (3 axis)
45	2 Pushbuttons (3 axis)
46	Low profile (3 axis)
50	3 Axis, IP67 Sealed
51	3 Axis, 1 Pushbutton, IP67 sealed
52	3 Axis, 2 Pushbuttons, IP67 sealed
55	3 Axis, 2 Pushbuttons, IP67 sealed

LIMITER PLATE

S	Square	
R	Round	
X	Slotted	
Y	Slotted	
P	Plus	
C	Cross	
W	Guided Feel Square	
Z	Guided Feel Round	

MOUNTING

- 1 Drop-in
- 4 Rear Mount \*

\* Rear mount not available with handle 55

OUTPUT OPTIONS<sup>1</sup>

0	0V-5V
1	0.5V-4.5V
2	0.25V-4.75V
3	1V-4V
4	0V to 5V - Sensor 1 0V to 5V - Sensor 2
5	0.5V to 4.5V - Sensor 1 0.5V to 4.5V - Sensor 2
6	0.25V to 4.75V - Sensor 1 0.25V to 4.75V - Sensor 2
7	1V to 5V - Sensor 1 1V to 5V - Sensor 2
8	0V to 5V - Sensor 1 5V to 0V - Sensor 2
9	0.5V to 4.5V - Sensor 1 4.5V to 0.5V - Sensor 2
10	0.25V to 4.75V - Sensor 1 4.75V to 0.25V - Sensor 2
11	1V to 4V - Sensor 1 4V to 1V - Sensor 2
0U	USB-Horizontal, mini B termination <sup>2</sup>
2U	USB-Vertical cable exit <sup>3</sup>
1J	Cursor Emulation
0V	0V TO 5V (Voltage Regulator)*
BV	±10V (Voltage Regulator)**
2C	CAN bus J1939
3C	CANopen

- 1 Output voltage is ratiometric to supply voltage
- 2 Cable length is 6' from side of joystick to USB connector
- 3 Cable length is 7' from side of joystick to USB connector

\* Requires operating voltage 6V ≥ 35V  
\*\* Requires operating voltage 11V ≥ 35V

# HF series

Proportional multi-axis fingertip controllers • non-contacting Hall effect technology

HANDLE 10

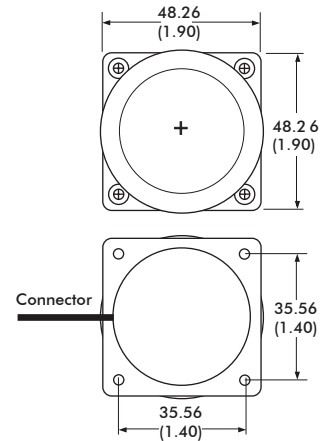
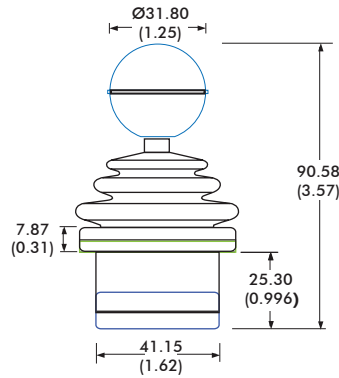

HANDLE 11

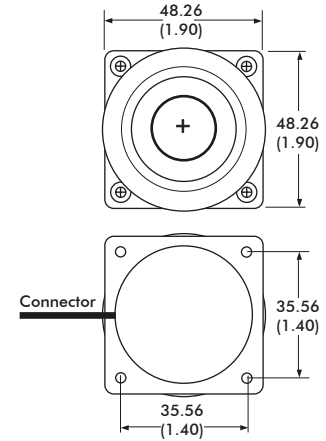
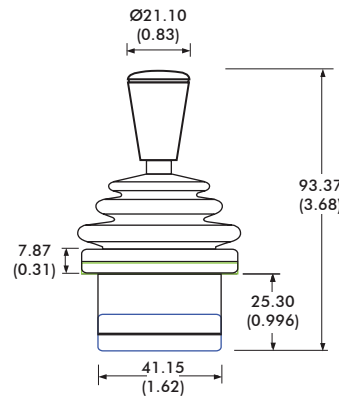

HANDLE 22

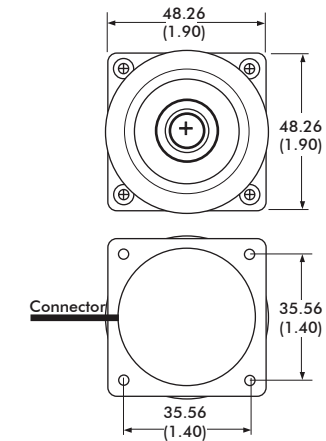
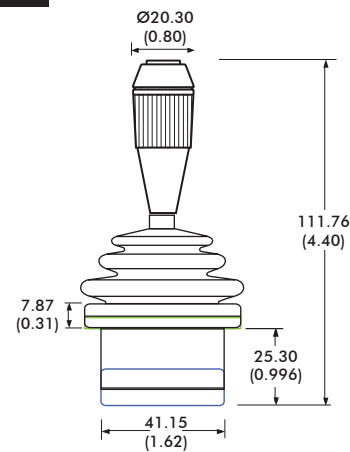

HANDLE 27

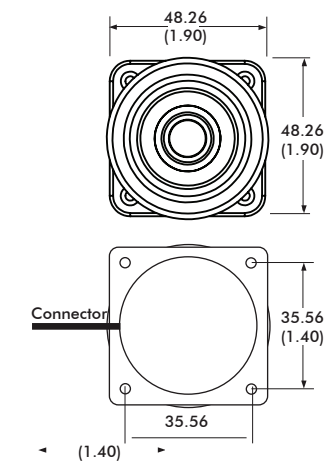
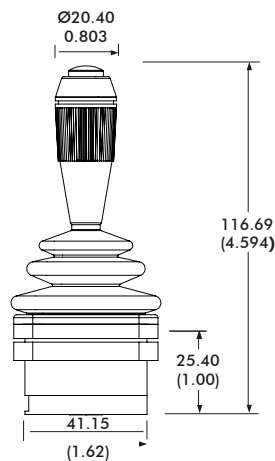

# HF series

Proportional multi-axis fingertip controllers • non-contacting Hall effect technology

HANDLE 33

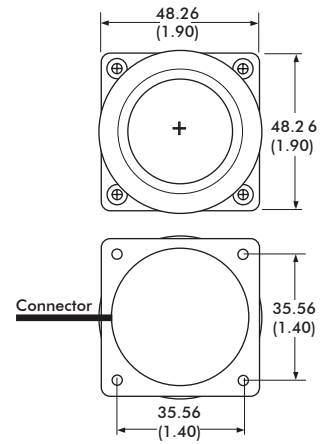
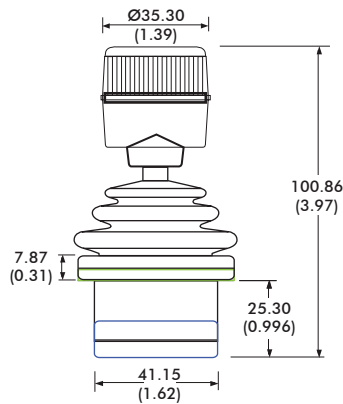

HANDLE 44

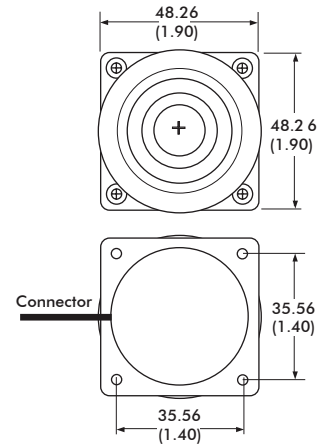
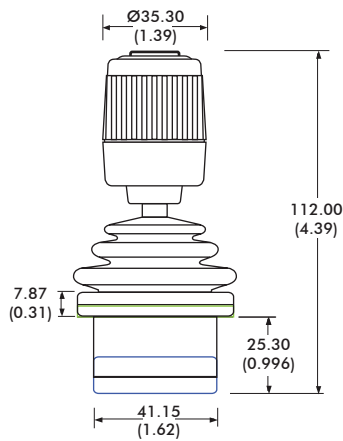

HANDLE 45

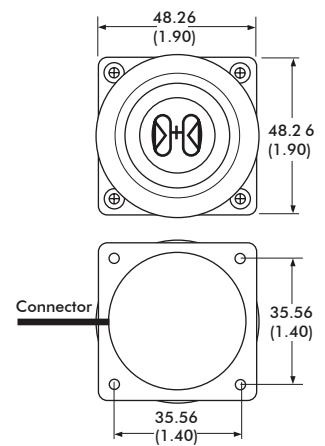
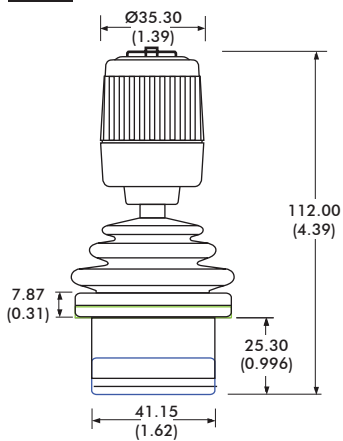

HANDLE 46

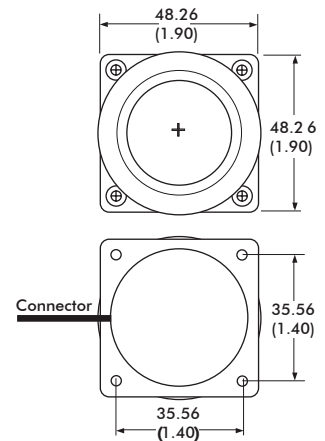
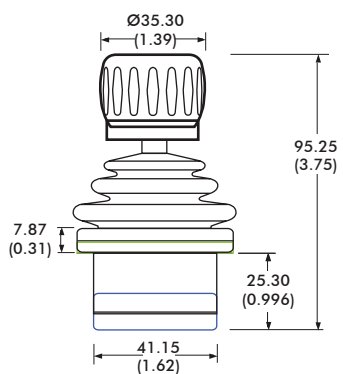

# HF series

Proportional multi-axis fingertip controllers • non-contacting Hall effect technology

**HANDLE 50**

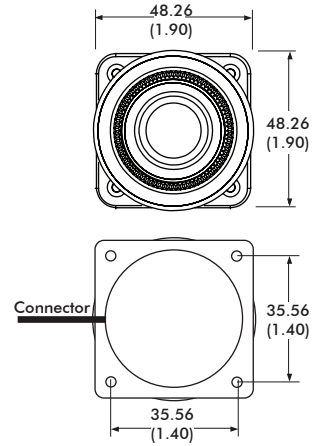
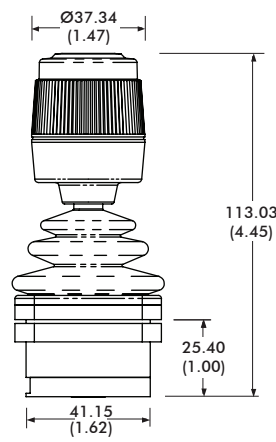

**HANDLE 51**

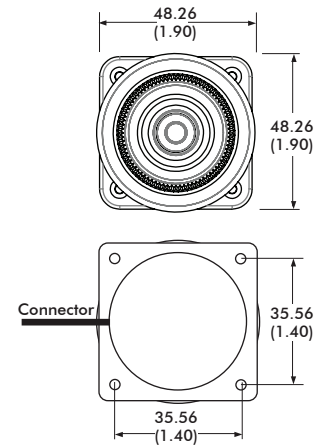
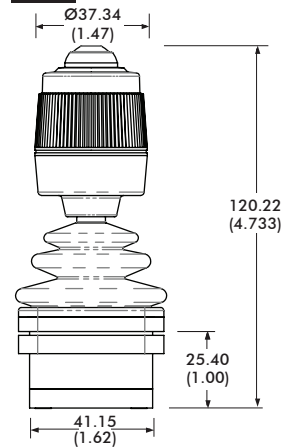

**HANDLE 52**

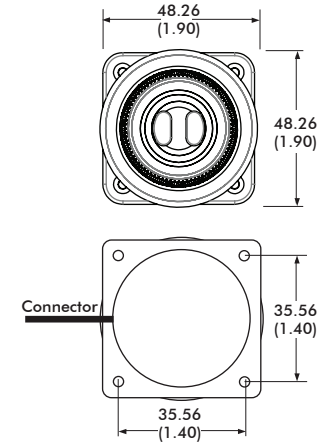
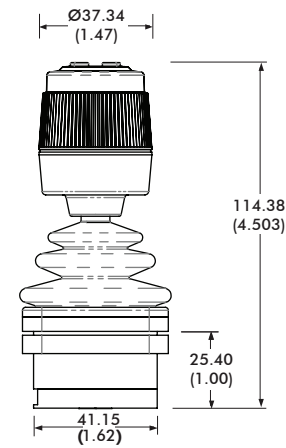

**HANDLE 55**

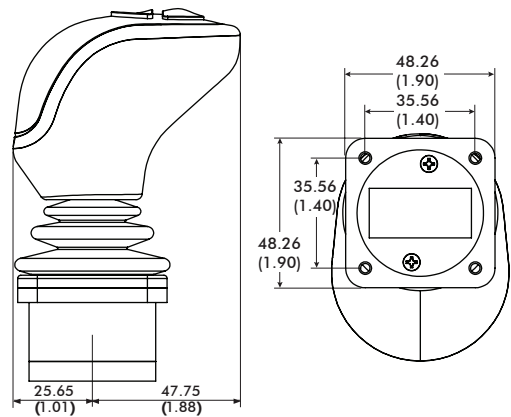
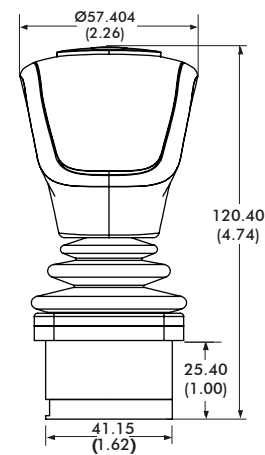

## X-ON Electronics

Largest Supplier of Electrical and Electronic Components

*Click to view similar products for [Joysticks](#) category:*

*Click to view products by [Apem](#) manufacturer:*

Other Similar products are found below :

[M11L0A1](#) [C1000C1P](#) [S10L0A1M](#) [G3-A1AM151NNNN](#) [TH500P00D4](#) [C1000C1PMJ0](#) [S10L061J](#) [60C22-M7-4-020S](#) [67A-DF-3C-060C](#)  
[60A00-8-050C](#) [60A00-4-050C](#) [60C22-M7-4-040S](#) [G3-0425](#) [S30L081F50](#) [3440SAT6476](#) [60A18-4-090C](#) [S30L081J](#) [M11L001C](#) [M11L0X1P](#)  
[USBM31Q081RMJ4S](#) [USBC200051JMJS](#) [TW08BLK12](#) [S30L0M1CSJBLK](#) [HF11R11](#) [HG-44MIS000-2654](#) [HG-44MIS000-U-2655](#)  
[4P182F1E55475](#) [TS4A1S00A](#) [BD140D01GR0000](#) [BD150SD4BL1200](#) [3140SAL6475](#) [TW01BLK11](#) [TW01GRY1](#) [ZD4PA203](#)  
[HF44S10UMJ0](#) [TS3N2S00A](#) [TS1R1U00A](#) [TS1R1S09A](#) [TS1D2S00A](#) [HFX45S02](#) [HFX10S00](#) [HF11P11](#) [4R28-2S1E-55-00](#)  
[BD150A01RE0000](#) [BD150D02BK1200](#) [ZD4PA24](#) [ZD4PA22](#) [ZD4PA12](#) [ZD4PA14](#) [J1-00105-S-G](#)