

## Evaluation Kit

### APPLICABLE PARTS (SOLD SEPARATELY)

- SA01

### INTRODUCTION

This easy-to-use kit provides a platform for the evaluation of PWM amplifiers using the SA01 pin-out configuration. It can be used to analyze a multitude of standard or proprietary circuit configurations, and is flexible enough to do most standard amplifier test configurations. The board is designed for surface mounting all components except the switching amplifier.

The schematic is shown in Figure 2. Note that all of the components shown on the schematic will probably not be used for any single circuit. Some components will simply be omitted, while others require installation of a jumper to complete the signal path.

Only components unique to the EK01 are provided in this kit. Hardware similar to that shown in Figure 7 must be obtained locally. The PC board and the foot print of the heatsink measure 3" by 5".

**Figure 1: PCB Layout**

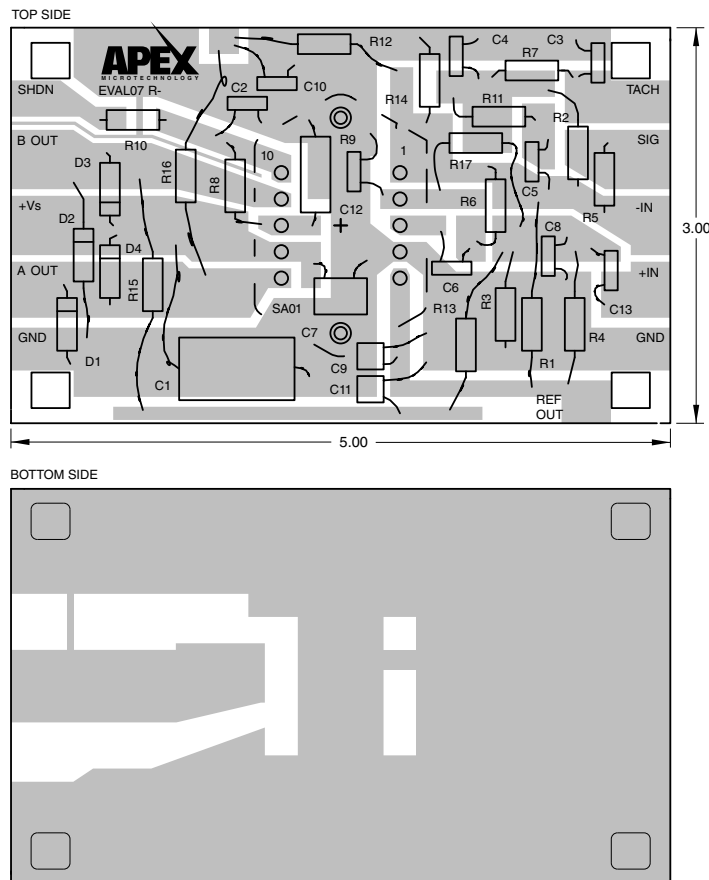

**Note:** Figure not shown to scale

Figure 2: PCB Schematic

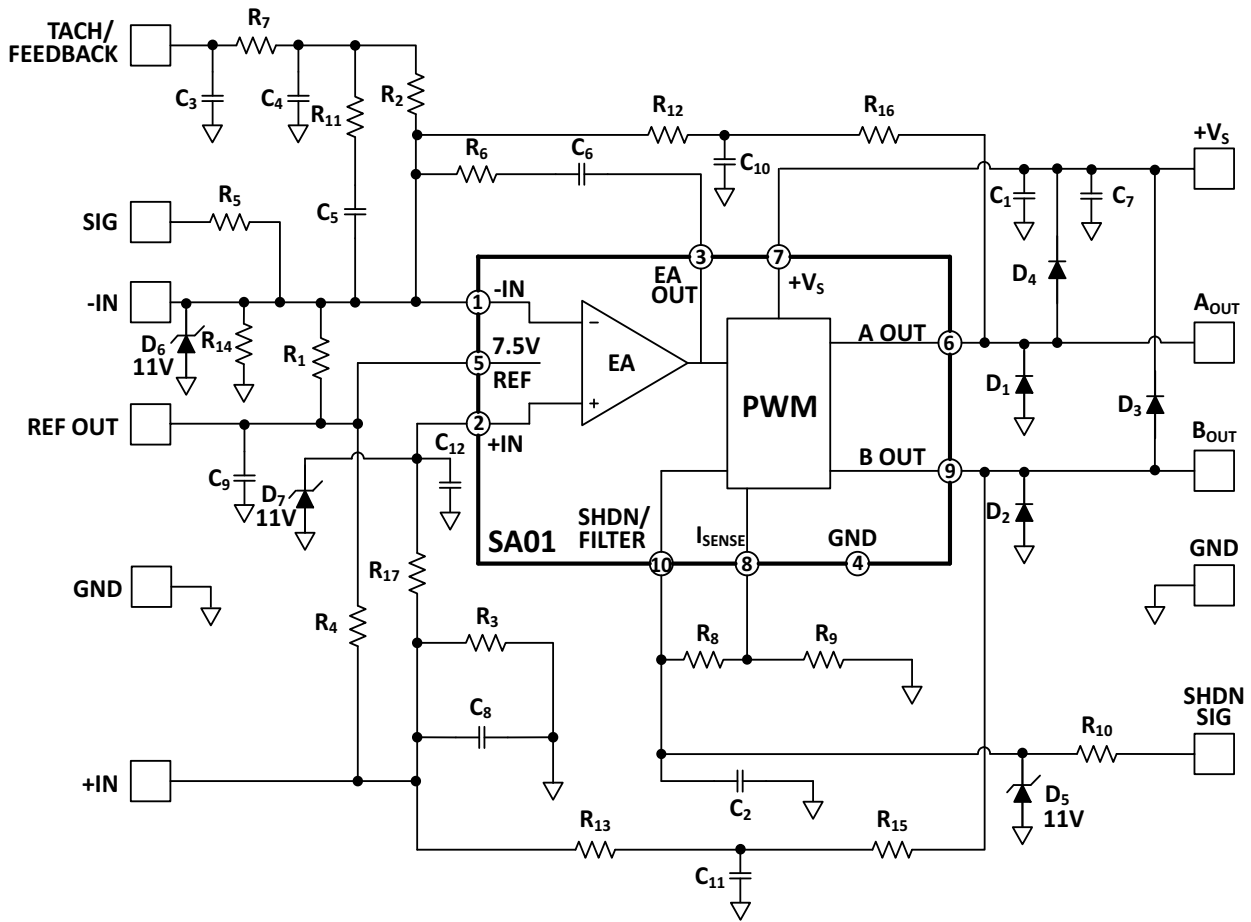

Figure 3: Open Loop Operation

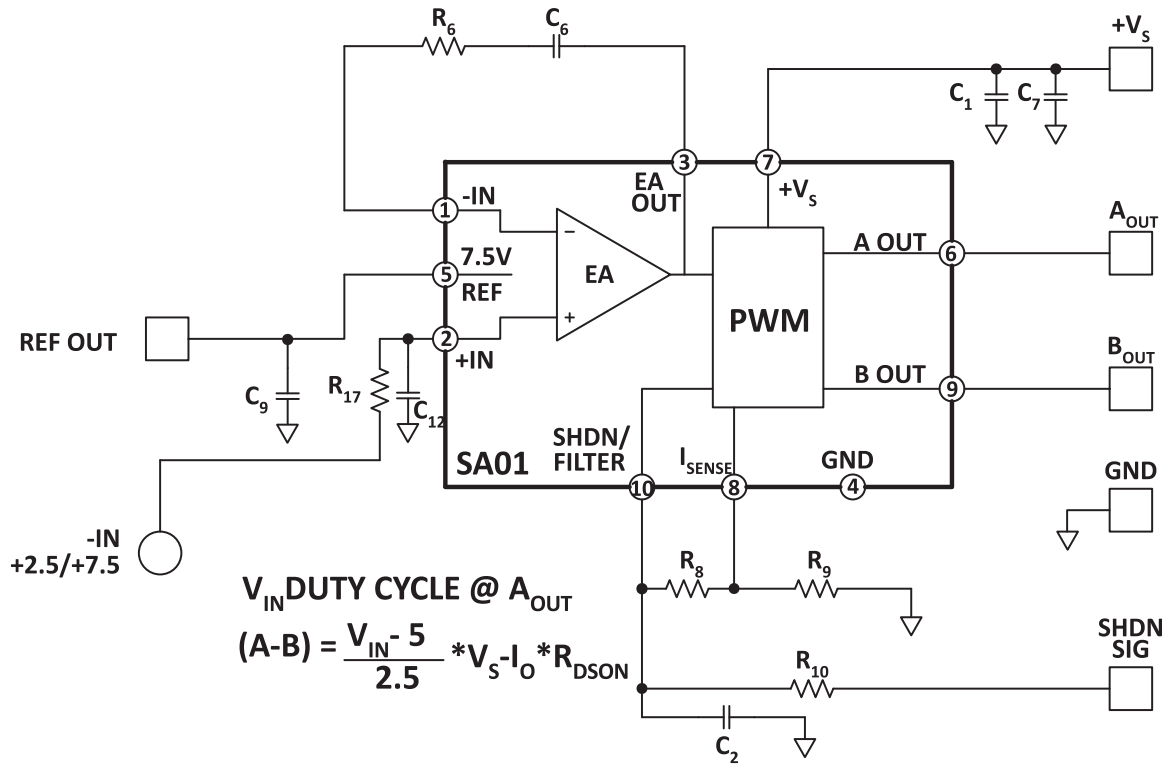

Figure 4: Voltage Control

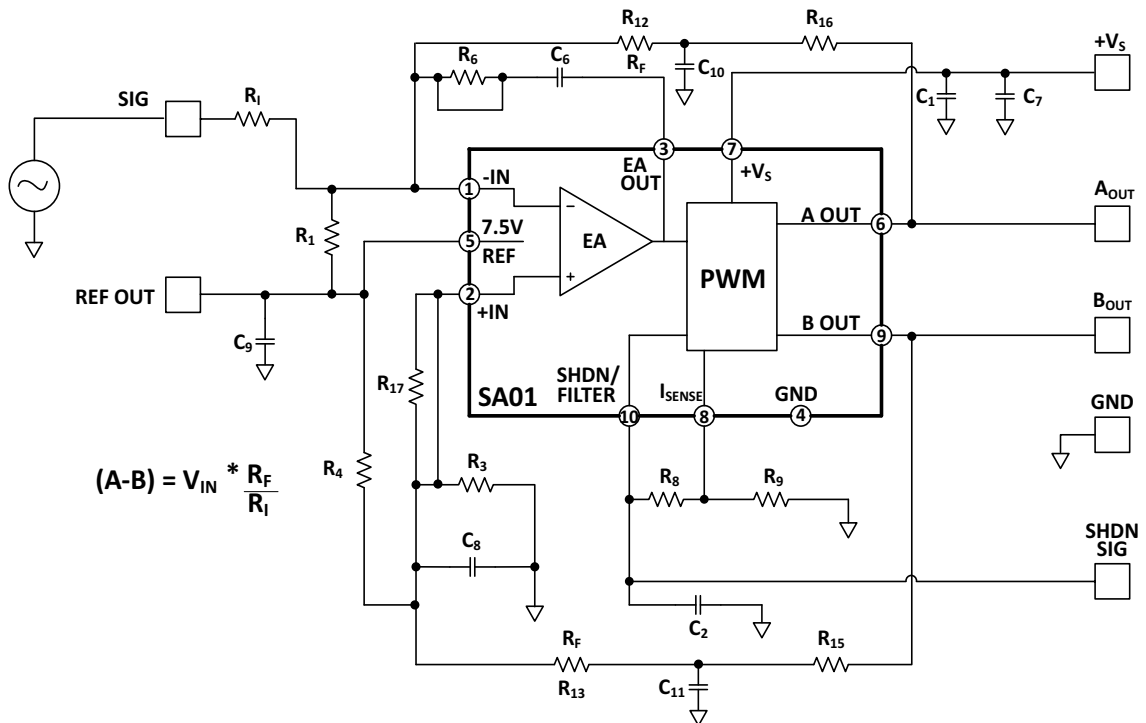

Figure 5: Position Control

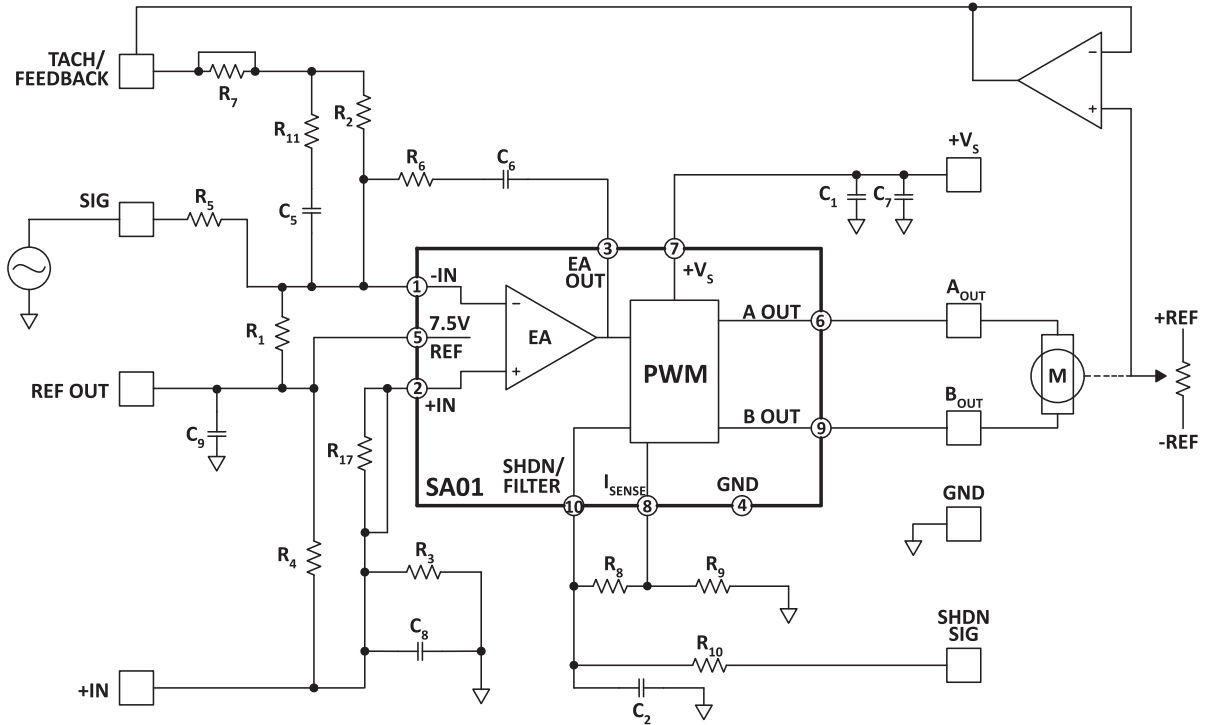
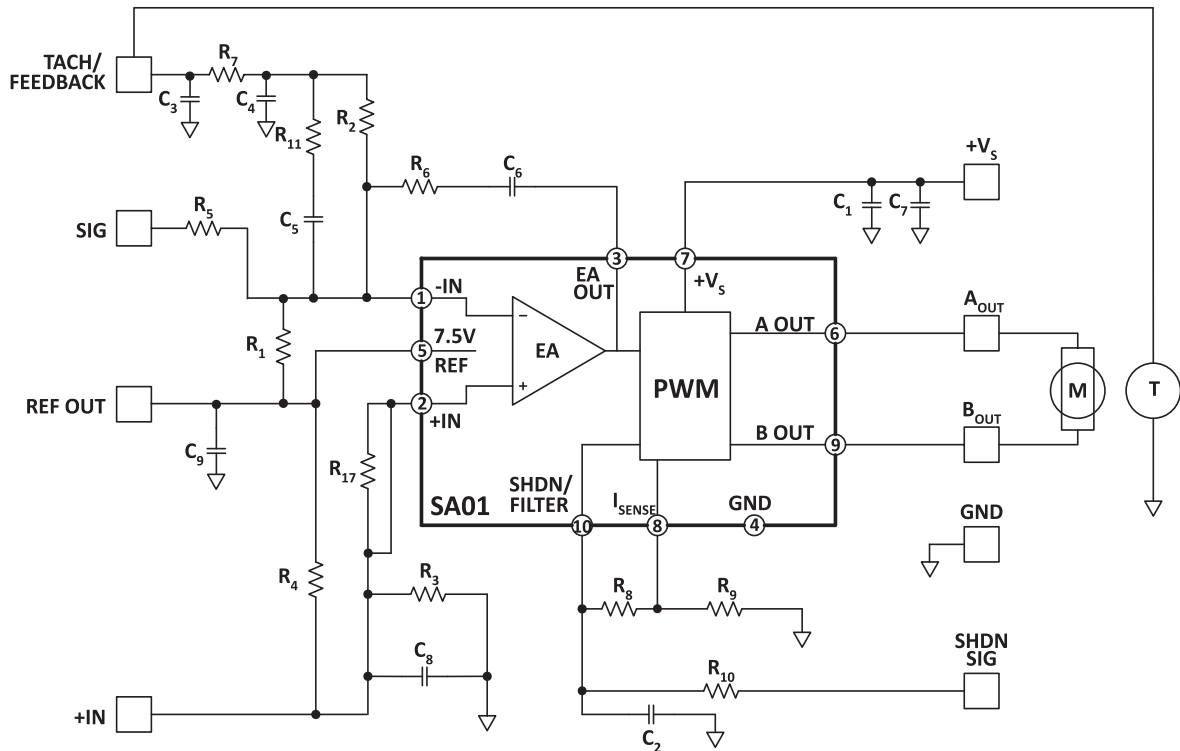

Figure 6: Speed Control



## TYPICAL COMPONENT FUNCTIONS

Component	Description
R1	Provides -IN bias from the Reference voltage.
R2	Sets DC scaling for external feedback such as tachometers, position sensors or current sensors.
R3	With R4 sets DC operating point of +IN, with R13 and R15 sets gain of voltage feedback circuit.
R4	With R3 sets DC operating point of +IN.
R5	Input scaling of the control signal.
R6	With C6 sets the corner frequency of the integrator.
R7	With C3 & C4 forms a low pass filter for the external feedback loop. Often used with tachometers.
R8	With C2 forms a low pass filter for the current limit circuit.
R9	Current sense. Often is a piece of resistance wire.
R10	With R8 divides shutdown signal voltage feeding SHDN/FILTER pin.
R11	With C5 sets corner frequency for external feedback loop.
R12, 13, 15, 16	Provides voltage feedback for a voltage controlled output.
R14	Helps set gain or scale input voltage levels.
R17	With C12 provides low pass filtering of +IN signal.
C1	Power supply bypass.
C2	With R8 form a low pass filter for the current limit circuit, also filters the SHDN signal.
C3, 4	With R7 forms a low pass filter for the external feed back loop. Often used with tachometers.
C5	With R11 sets corner frequency for external feedback loop.
C6	With R6 sets the corner frequency of the integrator.
C7	Power supply bypass, must have very low ESR in MHz range.
C8	Filters reference or feedback voltage at +IN.
C9	Bypass for the reference voltage.
C10, 11	With R15 and R16 provides low pass filtering of voltage feedback.
C12	With R17 provides low pass filtering of +IN signal.
C13	Provides AC coupling of +IN signal.
D1 - D4	Output protection flyback diodes.
D5 - D7	Input protection zener diodes.

## PARTS LIST

Reference	Manufacturer Part #	Description	QTY
	HS16	Heatsink	1
	MS04	PC Mount Cage Jacks	1 bag (12 each)
	EVAL07	PC Board	1
	60SPG00001	Spacer Gromets	4
	TW10	Thermal Washer	1 box (10 each)

## BEFORE YOU GET STARTED

- A SA01 PWM Amplifier is not included with EK01 and must be purchased separately.
- All Apex Microtechnology amplifiers should be handled using proper ESD precautions.
- Always use the heatsink included in this kit with thermal grease or thermal washer, TW10.
- Torque the part to the specified 8 to 10 in-lbs (0.9 to 1.13 N\*m).
- Always use adequate power supply bypassing.
- Do not change connections while the circuit is powered.
- Initially set all power supplies to the minimum operating levels allowed in the device data sheet.
- Check for oscillations.

## ASSEMBLY

1. From the non-silk screen side, insert and solder cage jacks. Be sure each one is fully seated.
2. From the non-silk screen side, push spacer grommets into PC board until fully seated. Grommets will snug when screws are inserted for heatsink mounting.
3. Apply TW10 thermal washer or a thin, even coat of thermal grease to the bottom of the SA01. If grease is from a tube make sure there is no sign separation of solids and liquids. If from a jar, stir it prior to application.
4. Use #14 sleeving to insulate and align at least 2 opposite pins of the amplifier.
5. Mount amplifier to heatsink using #6 screws and nuts. Do not over torque.
6. Install components as needed. External connections may be soldered directly or standard banana jacks may be soldered to these pads.
7. Insert amplifier pins into cage jacks and fasten board to heatsink.

**Figure 7: Assembly**

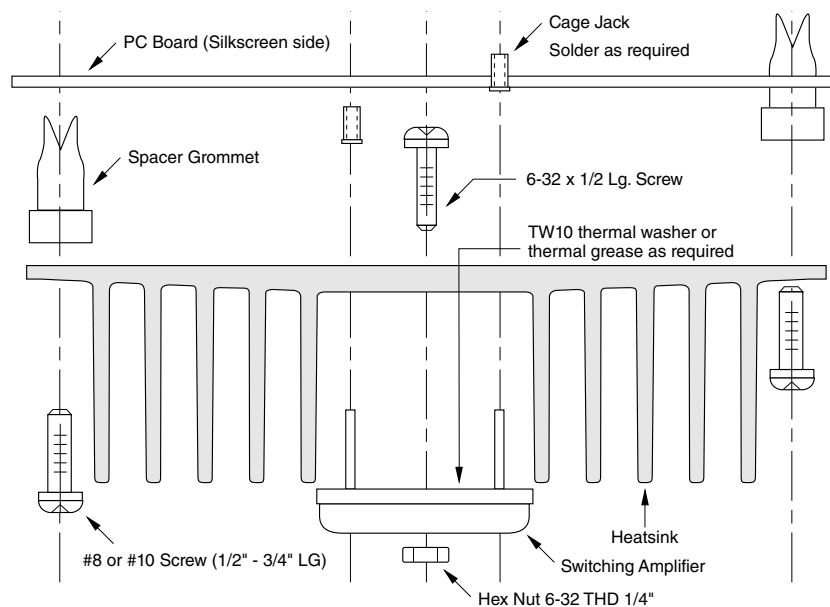

**Note: Not to size**

---

## **NEED TECHNICAL HELP? CONTACT APEX SUPPORT!**

For all Apex Microtechnology product questions and inquiries, call toll free 800-546-2739 in North America. For inquiries via email, please contact [apex.support@apexanalog.com](mailto:apex.support@apexanalog.com). International customers can also request support by contacting their local Apex Microtechnology Sales Representative. To find the one nearest to you, go to [www.apexanalog.com](http://www.apexanalog.com)

---

### IMPORTANT NOTICE

Apex Microtechnology, Inc. has made every effort to insure the accuracy of the content contained in this document. However, the information is subject to change without notice and is provided "AS IS" without warranty of any kind (expressed or implied). Apex Microtechnology reserves the right to make changes without further notice to any specifications or products mentioned herein to improve reliability. This document is the property of Apex Microtechnology and by furnishing this information, Apex Microtechnology grants no license, expressed or implied under any patents, mask work rights, copyrights, trademarks, trade secrets or other intellectual property rights. Apex Microtechnology owns the copyrights associated with the information contained herein and gives consent for copies to be made of the information only for use within your organization with respect to Apex Microtechnology integrated circuits or other products of Apex Microtechnology. This consent does not extend to other copying such as copying for general distribution, advertising or promotional purposes, or for creating any work for resale.

APEX MICROTECHNOLOGY PRODUCTS ARE NOT DESIGNED, AUTHORIZED OR WARRANTED TO BE SUITABLE FOR USE IN PRODUCTS USED FOR LIFE SUPPORT, AUTOMOTIVE SAFETY, SECURITY DEVICES, OR OTHER CRITICAL APPLICATIONS. PRODUCTS IN SUCH APPLICATIONS ARE UNDERSTOOD TO BE FULLY AT THE CUSTOMER OR THE CUSTOMER'S RISK.

Apex Microtechnology, Apex and Apex Precision Power are trademarks of Apex Microtechnology, Inc. All other corporate names noted herein may be trademarks of their respective holders.

## X-ON Electronics

Largest Supplier of Electrical and Electronic Components

*Click to view similar products for [Development Boards & Kits - Other Processors](#) category:*

*Click to view products by [Apex Microtechnology](#) manufacturer:*

Other Similar products are found below :

[EVB-MEC1418MECC](#) [20-101-1252](#) [CC-ACC-18M433](#) [STM8S/32-D/RAIS](#) [RTK0EN0001D01001BZ](#) [MAXQ622-KIT#](#)  
[YR0K50571MS000BE](#) [QB-R5F104PJ-TB](#) [CC-ACC-ETHMX](#) [OV-7604-C7-EVALUATION-BOARD](#) [SK-AD02-D62Q1747TB](#) [SK-BS01-D62Q1577TB](#) [ST7MDT1-EMU2](#) [GROVE BASE KIT FOR RASPBERRY PI](#) [CAB F-F\(40-17-RAINBOW\)](#) [CAB M-M\(40-17-RAINBOW\)](#)  
[CY3280-MBR3](#) [CY8CKIT-143A](#) [CY8CPROTO-062-4343W](#) [RASPBERRY PI PICO](#) [EK-MPC5744P](#) [KITAURIXTC234TFTTOBO1](#)  
[GENESYS ZU-5EV](#) [ENW89854AXKF](#) [ENWF9201AVEF](#) [QB-R5F104LE-TB](#) [LV18F V6 64-80-PIN TQFP MCU CARD EMPTY](#) [LV-24-33](#)  
[V6 44-PIN TQFP MCU CARD EMPTY](#) [LV-24-33](#) [V6 64-PIN TQFP MCU CARD EMPTY](#) [LV-24-33](#) [V6 80-PIN TQFP 1 MCU CARD](#)  
[EMPTY](#) [32X32 RGB LED MATRIX PANEL - 6MM PITCH](#) [3.3 - 5 VTRANSLATOR](#) [READY FOR XMEGA CASING \(WHITE\)](#) [RELAY4](#)  
[BOARD](#) [ETHERNET CONNECTOR](#) [RFID CARD 125KHZ - TAG](#) [RFID READER](#) [RFM12B-DEMO](#) [MAROON](#) [3G CLICK \(FOR](#)  
[EUROPE AND AUSTRALIA\)](#) [MAX232](#) [MAX3232 BOARD](#) [ARTY S7-50](#) [TINKERKIT HALL SENSOR](#) [TOUCHPANEL](#)  
[TOUCHPANEL CONTROLLER](#) [MIKROBOARD FOR AVR WITH ATMEGA128](#) [MIKROBOARD FOR PSOC WITH CY8C27643](#)  
[MIKROBUS CAPE](#) [MIKRODRIVE](#)