

## Evaluation Kit

### APPLICABLE PARTS (SOLD SEPARATELY)

- MP106

### INTRODUCTION

This easy to use kit provides a platform with good circuit board layout and grounding to evaluate MP106 Power Amplifier. The evaluation board provides options to install a load capacitor and series resistor to evaluate the MP106 performance with a print head. All necessary components are provided with the kit. External connections to the evaluation kit can be made through the connectors at the edges of the circuit. The circuit provides a line termination of 50Ω.

Figure 1: Circuit Configure Diagram

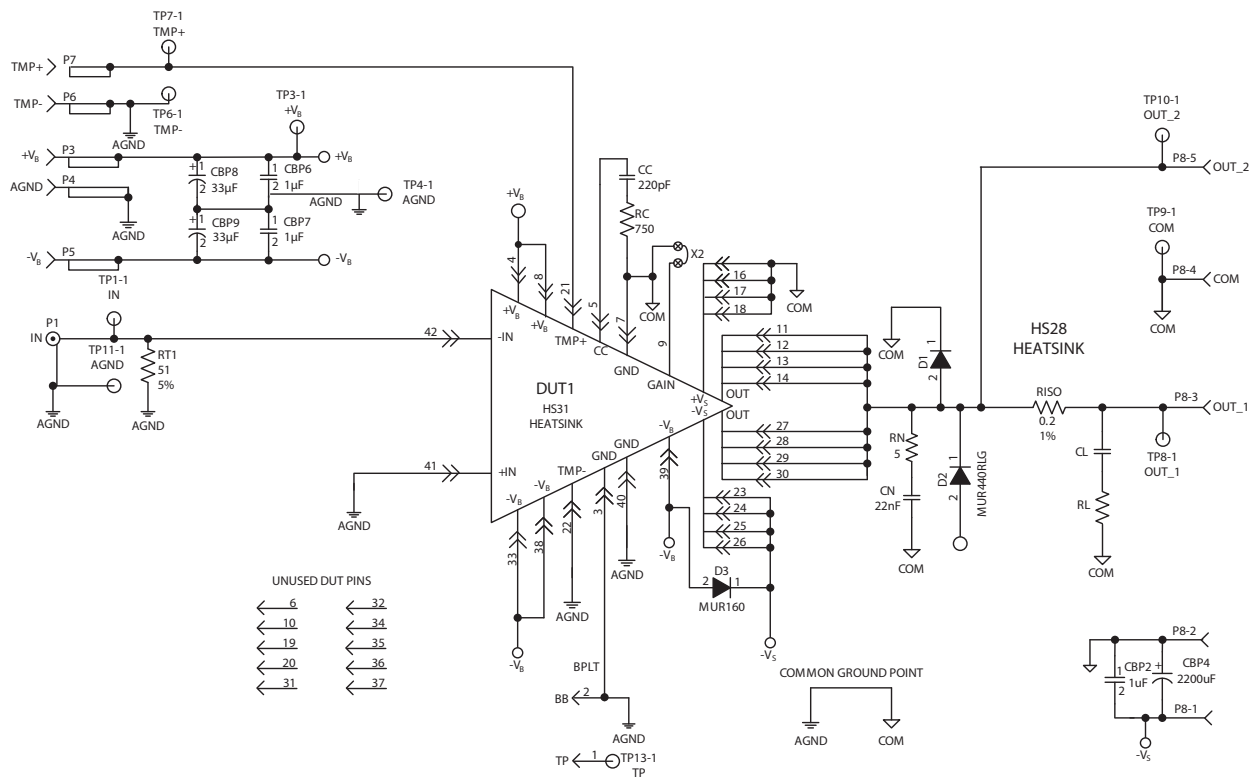
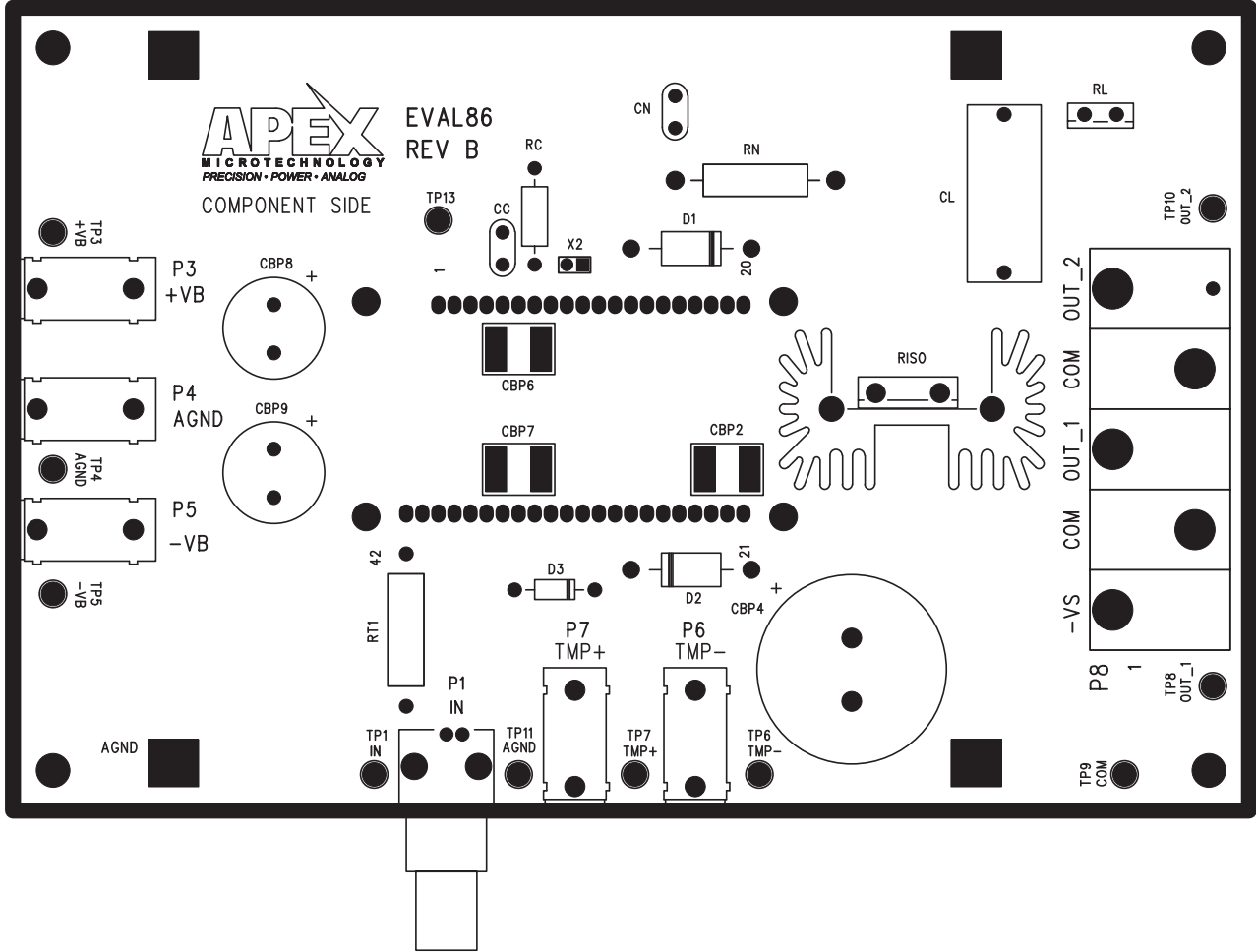

Figure 2: Board Layout



**PARTS LIST**

Reference	Apex Part #	Description	Qty
<b><u>Resistors</u></b>			
RT1	PR03000205109JAC00	51Ω, 3W, 5%	1
RC	CF14JT750R	750Ω, 1/4W, 5%	1
RN	RS01A5R000FE70	5Ω, 1W, 1%	1
RISO	MP9100-0.20-1%	0.2Ω, 100W, Metal	1
<b><u>Printed Circuit Board</u></b>			
EVAL 86	EVAL86	PRINTED CIRCUIT BOARD	1
<b><u>Capacitors</u></b>			
CC	CD16FD221JO3F	Mica, 220pF, 500 V,	1
CN	C322C223K1R5TA	Ceramic, 22nF, 100V	1
CBP4	LGU2D221MELY	Alum, 220uF, 200V	1
CBP2, CBP6, CBP7	C5750X7R2E105K230KA	Film, 1uF, 250V	3
CBP8, CBP9	KME400VB33RM16X31LL	Electrolytic, 33uF, 400V	2
<b><u>Diodes</u></b>			
D1, D2	MUR440RLG	Rectifier, Ultra-fast	2
D3	MUR160RLG	Rectifier, Ultra-fast	1
<b><u>Hardware</u></b>			
	HS31	Heatsink for Amplifier	1
	HS28	Heatsink for RISO	1
	MS11	Cage Jacks	2
	146510CJ	BNC Connector, PC Mount	1
	TS01	5 block terminal strip	1
	571-0100	Banana jacks, pc mount	5
	91735A190	Screw, Panhead, #8	4
	94997A350	Screw, Round head, #8	4
	90272A105	Screw, Panhead, #4	4
	60SPG00004	Spacer Grommets	4
	2221	Standoff, hex, #8	4
<b><u>Miscellaneous</u></b>			
	SPC02SVJN-RC	JUMPER, SLIP ON	10
	PRPC002SAAN-RC	HEADER, CONNECTOR	10
	5001	TEST POINT, PC MINI	10

## BEFORE YOU GET STARTED

- All Apex Microtechnology amplifiers should be handled using proper ESD precautions.
- Always use the heat sink included in this kit.
- Always use adequate power supply bypassing.
- Do not change the connections while the circuit is powered.
- Initially set all power supplies to the minimum operations levels allowed in the device data sheet.
- Check for oscillations.
- Please refer to Application Note, AN01 for general operating conditions.

## ASSEMBLY INSTRUCTIONS

During the assembly, please refer to the circuit schematics, assembly drawings, and the data sheet of the part being used on the evaluation kit.

1. Note that each side of the circuit board is identified as either the component side or the DUT side. The component side has the designators printed on that side.
2. All through hole components (except the cage jacks) are installed on the component side of the board and soldered on the DUT side.
3. 42 pin receptacles are supplied with this evaluation kit. Break it in two strips 20 and 22 pin receptacles. Insert the carrier strip through the DUT side, and solder the cage jacks on the component side. Once the cage jacks are soldered, remove the carrier strip, leaving only cage jacks soldered on the board.
4. Install CBP2, CBP6, CBP7, CBP8 and CBP9 on the component side of the board.
5. Install diodes, D1, D2, D3 and capacitor CBP4 on the component side of the board. Ensure that the orientation of the components match the circuit schematic drawing.
6. Break off a 2-position pin header from the provided row of 10 header connectors and install in X1.
7. Next install all the smaller components on the board. This is done because it becomes difficult to install a smaller part on the board once all the larger components are installed.
8. Mount the BNC connector provided with the kit (146510CJ) and solder it to the board. Also mount the banana jacks on the board. Install other miscellaneous components like jumpers and test points to complete your application circuit.
9. From the DUT side of the PCB, snap the spacer-grommets into the holes at the four corners of the PCB. Notice that the holes are slightly rectangular and match the spacer-grommets long and short sides to the holes in the PCB.
10. Apply a thin, uniform layer of thermal grease to the amplifier; a straight edge may be useful here. Position the amplifier over the mounting holes in the heatsink. Firmly push the amplifier onto the heatsink while slightly rotating the amplifier back and forth, ending with the mounting holes of the amplifier over the mounting holes in the heatsink.
11. Use 4-40x $\frac{1}{4}$ ' machine screws to mount the amplifier to the heatsink. Do not over-tighten the screws as this provides no thermal benefit and may break the hardware.
12. Carefully lower the PCB assembly until the pins of the amplifier engage the cage jacks and then continue pushing the PCB assembly in the area between the amplifier's pins until the four spacer grommets at the four corners of the PCB touch the heatsink. At this point the PCB should not be bowed.
13. Use #8 sheet metal screws to mount the PCB to the heat sink at the four spacer-grommets.
14. #8 hex stand offs (91841A009) are also provided with the kit. Install the # 8 x 0.375" screws (91735A190), provided with the kit, from the component side. Attach the standoffs to these screws on the corners of the board. Refer to the assembly drawings while installing the standoffs.

15. Connect the external connections via the BNC connector and banana jacks. Hook up power supplies and signals as necessary. The amplifier is now ready for evaluation.

**Figure 3: Top View**

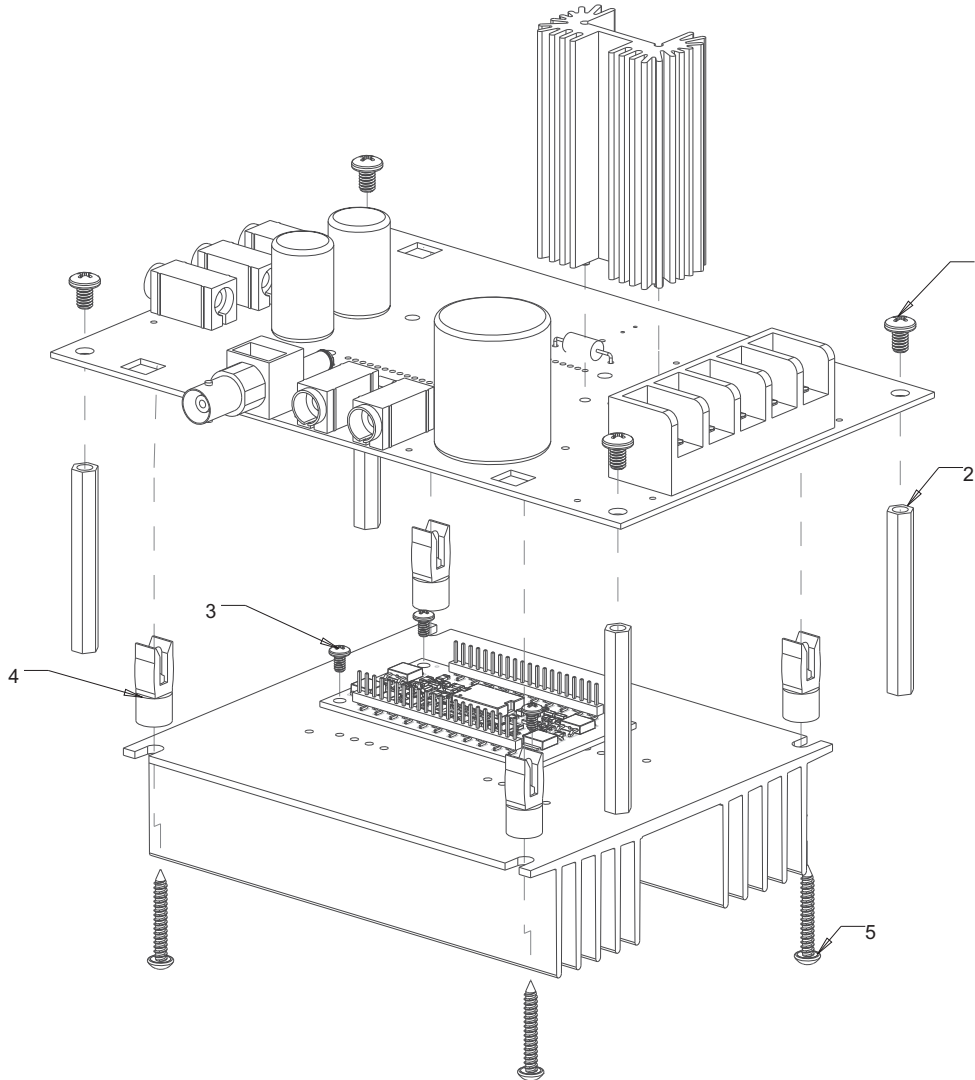

1. 4 X #8 X 0.375" SCREW
2. 4 X #8 X 2.00" HEX STANDOFFS
3. 4 X #4 X 0.187" SCREW
4. 4 X SPACER GROMMETS
5. 4 X #8 X 0.98" SCREW

Figure 4: Bottom View

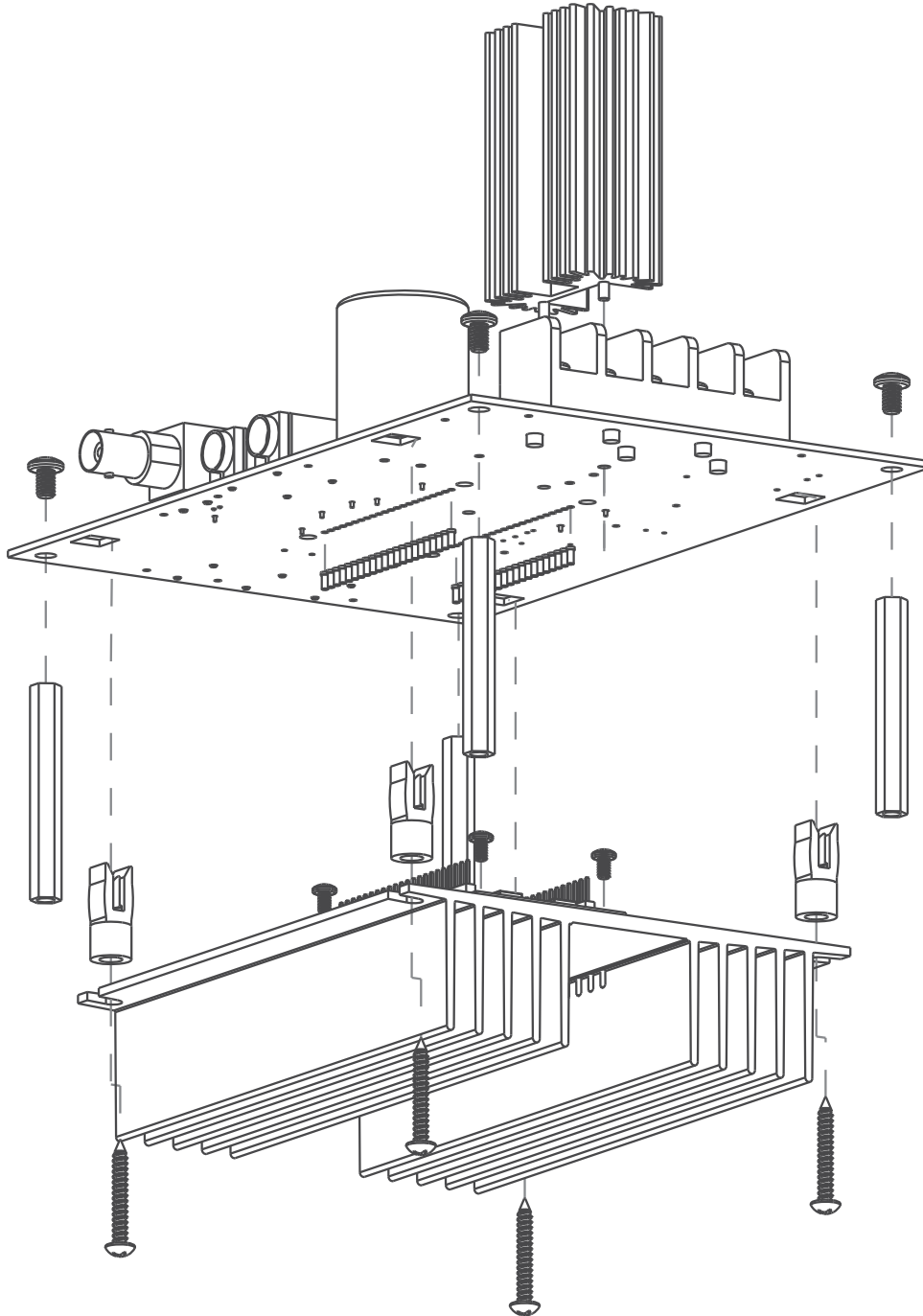

## TEST ASSEMBLY

### EQUIPMENT NEEDED

1. Power Supply
2. Function Generator
3. Oscilloscope
4. Proper Heat Sink System (if operating at high current)

### TEST SETUP

The positive power supply pin (+VS) is grounded. Connect the negative power supply using a banana jack to terminal -VS and ground to terminal COM. Connect the positive and negative boost supply (+VB and -VB) to terminals P3 and P5 and connect ground connection to terminal P4.

Test the evaluation kit at low power supply voltage first. The -Vs power supply should be switched on before switching on the boost supplies.

When the board is not loaded, or loaded with a resistive load, the output voltage can be checked at terminal Out\_2. If a reactive load is connected, the load should be connected to terminal Out\_1. Out\_1 terminal is connected to an isolation resistor (RISO) and a snubber circuit.

**Note:** For added precaution, power on the circuit with the amplifier removed. Check the voltage at each cage jack without the DUT, for correct voltage / signal at each respective pin. Once this is done, plug in the DUT and check for the correct signal.

### TEST RESULTS

For the test, a 540nF capacitive load was used. The input was set to 2.02V pulse, with a 100mV offset, and the output is around 30V. The test results can be seen in figure 5. The output of the amplifier is set with a fixed riding edge and falling edge slew rate. The output is 15 times that of the input.

**Figure 5: Output Waveforms**

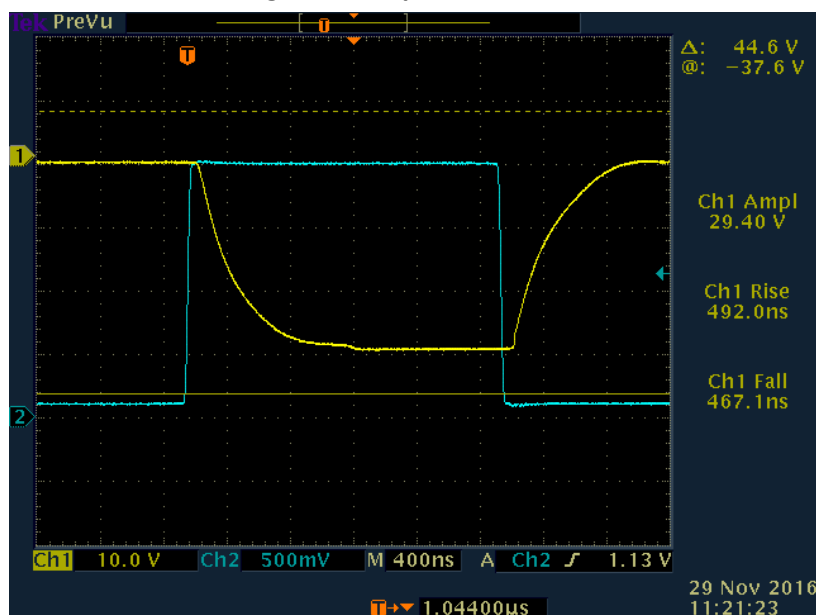

---

## **NEED TECHNICAL HELP? CONTACT APEX SUPPORT!**

For all Apex Microtechnology product questions and inquiries, call toll free 800-546-2739 in North America. For inquiries via email, please contact [apex.support@apexanalog.com](mailto:apex.support@apexanalog.com). International customers can also request support by contacting their local Apex Microtechnology Sales Representative. To find the one nearest to you, go to [www.apexanalog.com](http://www.apexanalog.com)

---

### IMPORTANT NOTICE

Apex Microtechnology, Inc. has made every effort to insure the accuracy of the content contained in this document. However, the information is subject to change without notice and is provided "AS IS" without warranty of any kind (expressed or implied). Apex Microtechnology reserves the right to make changes without further notice to any specifications or products mentioned herein to improve reliability. This document is the property of Apex Microtechnology and by furnishing this information, Apex Microtechnology grants no license, expressed or implied under any patents, mask work rights, copyrights, trademarks, trade secrets or other intellectual property rights. Apex Microtechnology owns the copyrights associated with the information contained herein and gives consent for copies to be made of the information only for use within your organization with respect to Apex Microtechnology integrated circuits or other products of Apex Microtechnology. This consent does not extend to other copying such as copying for general distribution, advertising or promotional purposes, or for creating any work for resale.

APEX MICROTECHNOLOGY PRODUCTS ARE NOT DESIGNED, AUTHORIZED OR WARRANTED TO BE SUITABLE FOR USE IN PRODUCTS USED FOR LIFE SUPPORT, AUTOMOTIVE SAFETY, SECURITY DEVICES, OR OTHER CRITICAL APPLICATIONS. PRODUCTS IN SUCH APPLICATIONS ARE UNDERSTOOD TO BE FULLY AT THE CUSTOMER OR THE CUSTOMER'S RISK.

Apex Microtechnology, Apex and Apex Precision Power are trademarks of Apex Microtechnology, Inc. All other corporate names noted herein may be trademarks of their respective holders.



## X-ON Electronics

Largest Supplier of Electrical and Electronic Components

*Click to view similar products for [Development Boards & Kits - Other Processors](#) category:*

*Click to view products by [Apex Microtechnology](#) manufacturer:*

Other Similar products are found below :

[EVB-MEC1418MECC](#) [20-101-1252](#) [CC-ACC-18M433](#) [STM8S/32-D/RAIS](#) [RTK0EN0001D01001BZ](#) [MAXQ622-KIT#](#)  
[YR0K50571MS000BE](#) [QB-R5F104PJ-TB](#) [CC-ACC-ETHMX](#) [OV-7604-C7-EVALUATION-BOARD](#) [SK-AD02-D62Q1747TB](#) [SK-BS01-D62Q1577TB](#) [ST7MDT1-EMU2](#) [GROVE BASE KIT FOR RASPBERRY PI](#) [CAB F-F\(40-17-RAINBOW\)](#) [CAB M-M\(40-17-RAINBOW\)](#)  
[CY3280-MBR3](#) [CY8CKIT-143A](#) [CY8CPROTO-062-4343W](#) [RASPBERRY PI PICO](#) [EK-MPC5744P](#) [KITAURIXTC234TFTTOBO1](#)  
[GENESYS ZU-5EV](#) [ENW89854AXKF](#) [ENWF9201AVEF](#) [QB-R5F104LE-TB](#) [LV18F V6 64-80-PIN TQFP MCU CARD EMPTY](#) [LV-24-33](#)  
[V6 44-PIN TQFP MCU CARD EMPTY](#) [LV-24-33](#) [V6 64-PIN TQFP MCU CARD EMPTY](#) [LV-24-33](#) [V6 80-PIN TQFP 1 MCU CARD](#)  
[EMPTY](#) [32X32 RGB LED MATRIX PANEL - 6MM PITCH](#) [3.3 - 5 VTRANSLATOR](#) [READY FOR XMEGA CASING \(WHITE\)](#) [RELAY4](#)  
[BOARD](#) [ETHERNET CONNECTOR](#) [RFID CARD 125KHZ - TAG](#) [RFID READER](#) [RFM12B-DEMO](#) [MAROON](#) [3G CLICK \(FOR](#)  
[EUROPE AND AUSTRALIA\)](#) [MAX232](#) [MAX3232 BOARD](#) [ARTY S7-50](#) [TINKERKIT HALL SENSOR](#) [TOUCHPANEL](#)  
[TOUCHPANEL CONTROLLER](#) [MIKROBOARD FOR AVR WITH ATMEGA128](#) [MIKROBOARD FOR PSOC WITH CY8C27643](#)  
[MIKROBUS CAPE](#) [MIKRODRIVE](#)