

Evaluation Kit

APPLICABLE PARTS (SOLD SEPARATELY)

- MSA240KC
- MSA260KC

INTRODUCTION

This easy-to-use kit provides a platform for the evaluation of PWM circuits using the MSA240KC/260KC pin out. With ample bread boarding areas it is flexible enough to analyze a multitude of standard or proprietary circuit configurations. Critical connections for power supply bypassing are pre-wired. Components not usually readily available in engineering labs are provided. External connection to the evaluation kit can be made via the terminal block and banana jacks at the edges of the circuit board.

Figure 1: PCB

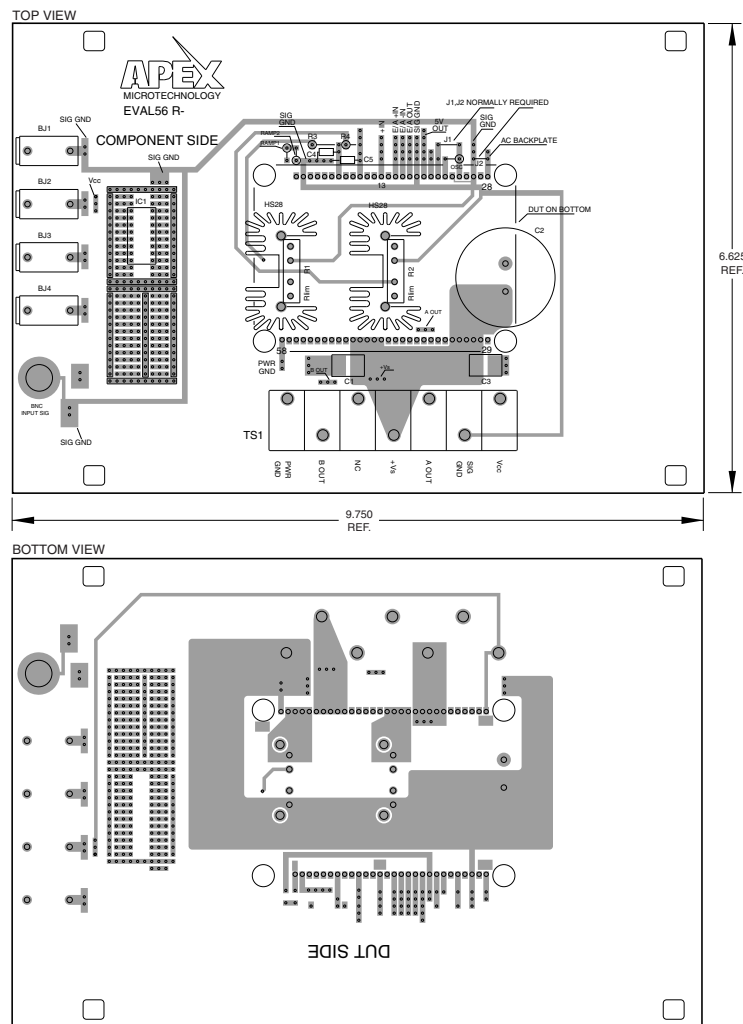
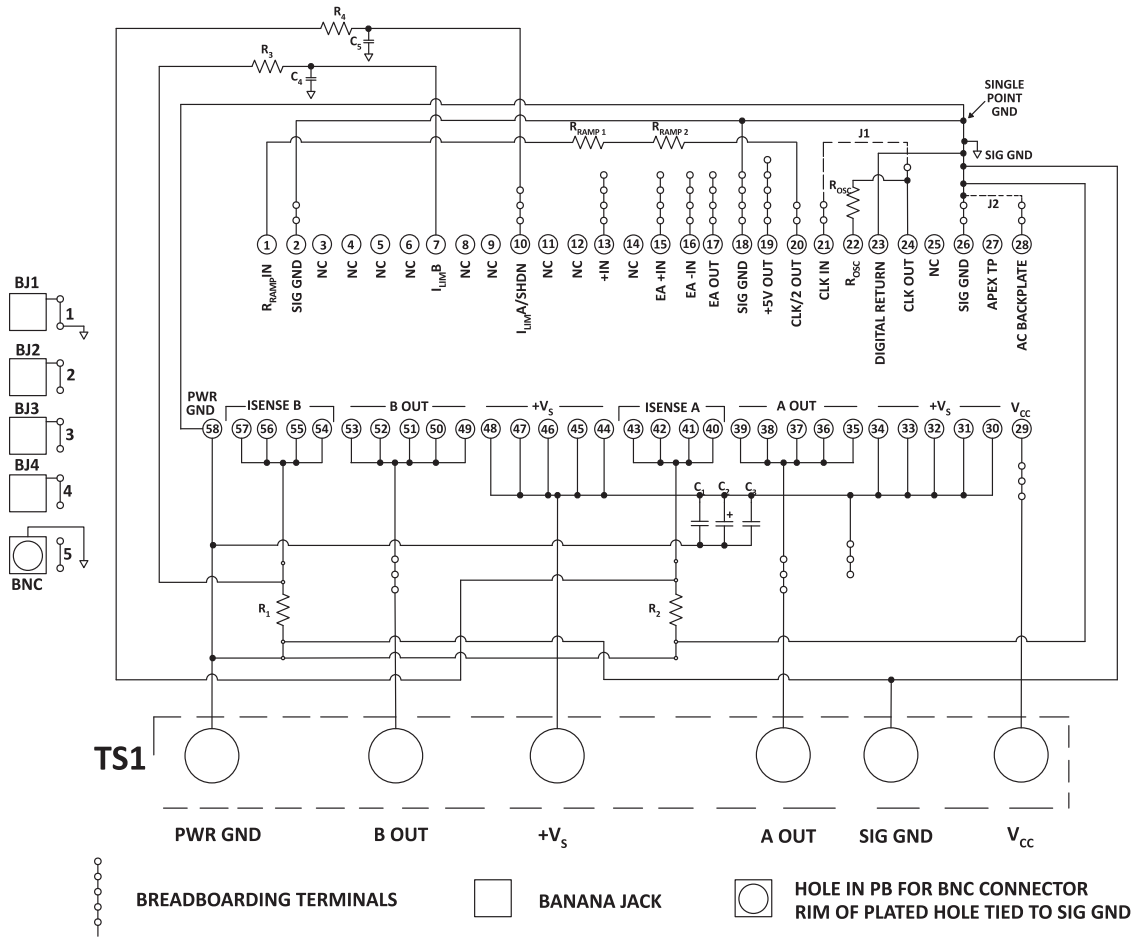

Figure 2: Schematic Diagram



NOTE: BREAD BOARDING ARRAY NOT SHOWN
 NOTE: J1 AND J2 NORMALLY REQUIRED.

PARTS LIST

Reference	Manufacturer Part #	Description/Vendor	QTY
	HS28	Heat Sink	2
	HS26	Heat Sink	1
	MS11	30-pin socket carrier strip	2
	EVAL56	PC Board	1
	60SPG00004	Spacer Grommets/Micro Plastics	4
BJ1-4	571-0100	Banana Jack, Deltron 571-0100	4
C1,3	ZX7R105KTL	1uf 500V Cap, Novacap ST2225B105K501LLXW	2
For identification note this capacitor has “legs”.			
C2*	82DA222M100KC2D	2200uF 100V, United Chemi-Con	1
C2*	KMH450VN471M35X50T2	470uF 450V, United Chemi-Con	1
TS1	TS02	Terminal Strip	1
R1,2*	PBV-R020-1	0.020Ω Resistor	2
R1,2*	PBV-R010-1	0.010Ω Resistor	2
R1,2*	PBV-R015-1	0.015Ω Resistor	2

*Chosen per directions

BEFORE YOU GET STARTED

- All Apex Microtechnology amplifiers should be handled using proper ESD precautions.
- Do not change connections while the circuit is powered.
- Initially set all power supplies to the minimum operating voltage allowed in the device data sheet.
- Always use the heatsink provided in this kit and proper power supply bypassing.
- Please refer to Application Note 1, AN01, for general operating considerations.

ASSEMBLY

During assembly refer to Figure 3 and the data sheet for the product you are using, either the MSA240KC or MSA260KC.

1. Note that each side of the circuit board is identified as either the component side or “DUT side”.
2. Two 30-pin socket strips have been supplied with this kit that have been loaded with cage jacks. Using wire cutters trim the carrier to remove two sockets from one of the strips. Insert the socket strips from the “DUT side” of the board and solder the jacks from the “component side” of the board, making sure that each socket strip is fully seated before soldering. After soldering the jacks remove and discard the plastic carrier.
3. Solder the surface mount capacitors at C1 and C3 on the “component side” of the board.
4. From the “component side” mount banana jacks at BJ1-4 and solder from the “DUT Side” of the circuit board. Cut off excess lead lengths. Note that BJ1 is connected to SIG GND.
5. Several low ohm value resistors are provided with this evaluation kit: 0.020Ω, 0.015Ω and 0.010Ω. These are used to implement current limiting in the output circuit. Select the value most appropriate for your application. Refer to the product data sheet to determine which resistor value you should use.
6. From the “component side” of the PCB mount the HS28 heat sink closest to C2 (to be added later) and solder the mounting tabs of the heat sink from the “DUT side” with a high capacity soldering iron.

7. Apply a thin layer of thermal grease on the back of the chosen current limiting sense resistor R2 and insert the resistor into the PCB. Mount the resistor to the HS28 heat sink using #4 screw and nut hardware (not supplied). Place the screw into the mounting hole from the narrow-channel side of the heat sink and place the nut on the screw from the wide-channel side of the heat sink. Do not over tighten the screw. Finally, solder the resistor terminals to the PCB and **cut off the excess lead length**.
8. Mount the remaining HS28 heat sink similarly to step 6.
9. Repeat step 7 for R1 and the second HS28 heat sink.
10. Mount the electrolytic capacitor at C2 from the “component side” of the PCB. Match the polarity markings on the capacitor with the polarity markings on the PCB. Use the correct voltage capacitors for the product you are using: A 100V capacitor for the MSA240KC, or a 450V capacitor for the MSA260KC. Be sure the capacitors have snapped into the PCB and solder from the “DUT side” of the PCB. Be sure to fill the holes with solder.
11. Mount the terminal strip to the “component side” of the PCB. Make sure the terminal strip is fully seated and solder the pins from the “DUT side” of the PCB. Be sure to fill the mounting holes with solder.
12. Mount a BNC connector (not supplied) to the PCB at location 5 (near the banana jacks) if desired. The body of the BNC connector is tied to SIG GND.
13. Mount other components to complete your application circuit using the pads and holes provided. Refer to the data sheet for your model and note that:

$$R_{RAMP} = 2XR_{OSC}$$

It is therefore convenient to use 3 resistors of equal value and make up R_{RAMP} from two of those resistors. Note on the PCB locations for R_{RAMP1} and R_{RAMP2} to do this.

14. From the “DUT side” of the PCB snap the spacer- grommets into the holes at the four corners of the PCB. Notice that the holes are slightly rectangular and match the spacer-grommet's long and short sides to the holes in the PCB.
15. Apply a thin, uniform layer of thermal grease to the amplifier; a straight edge may be useful here. Position the amplifier over the mounting holes in the heatsink. Firmly push the amplifier onto the heatsink while slightly rotating the amplifier back and forth, ending with the mounting holes of the amplifier over the mounting holes in the heatsink.
16. Attach the amplifier to the heatsink with 4-40x½' male-female hex spacers (not supplied). These spacers serve as alignment pins and aide in the assembly of the PCB to the heatsink. Alternatively, use 4-40x¼' machine screws to mount the amplifier to the heatsink. Do not over-tighten the spacers or screws as this provides no thermal benefit and may break the hardware.
17. Place the PCB assembly on the heatsink/amplifier assembly so that the hex spacers come through the aligning holes near the corners of the amplifier location in the PCB. Carefully lower the PCB assembly until the pins of the amplifier engage the cage jacks. Alternately, sight through the aligning holes in the PCB and match-up the PCB to the screws used to mount the amplifier. In either case be sure the pins of the amplifier are engaged with the cage jacks and then continue pushing the PCB assembly in the area between the amplifier's pins until the four spacer grommets at the four corners of the PCB touch the heatsink. At this point the PCB should not be bowed.
18. Using #8 X 1" sheet metal screws (not provided) mount the PCB to the heat sink at the four spacer-grommets.
19. Hook up power and signals as necessary. The amplifier is now ready for testing.

Figure 3: Assembly

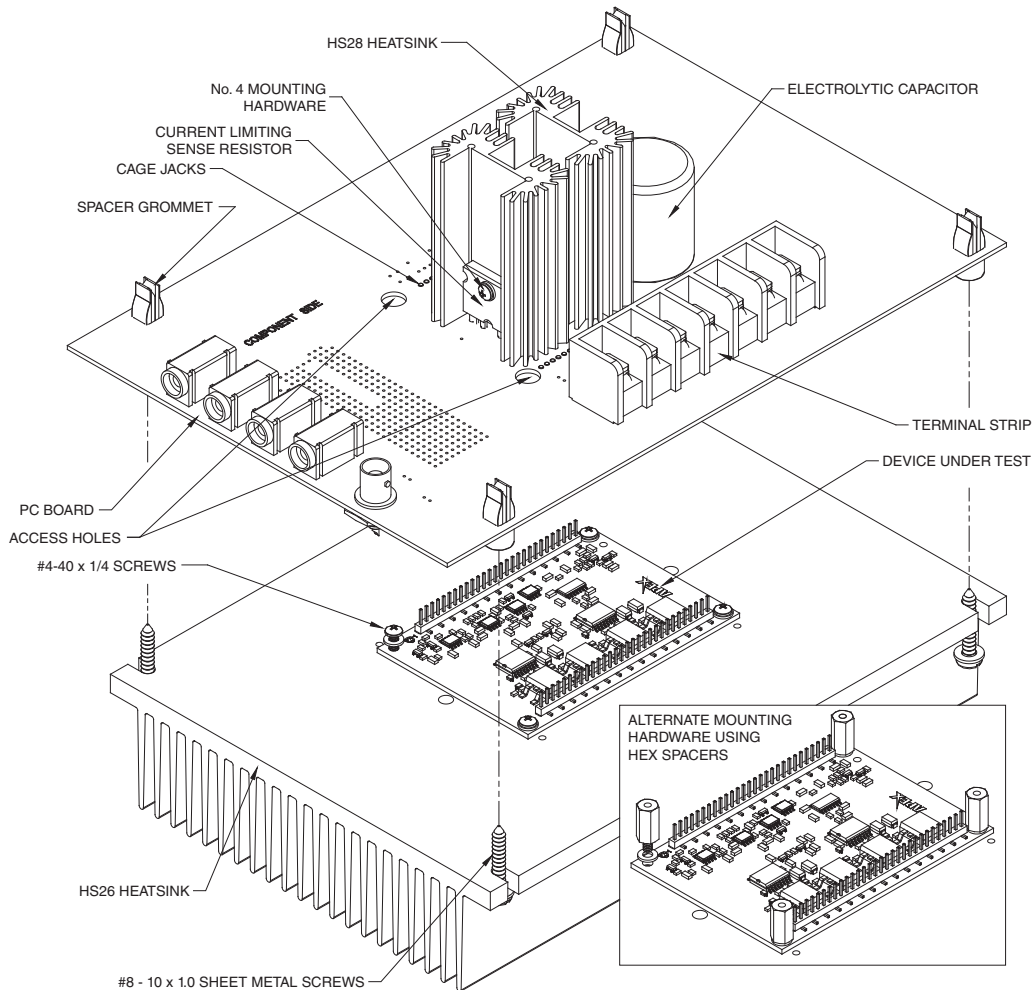

NEED TECHNICAL HELP? CONTACT APEX SUPPORT!

For all Apex Microtechnology product questions and inquiries, call toll free 800-546-2739 in North America. For inquiries via email, please contact apex.support@apexanalog.com. International customers can also request support by contacting their local Apex Microtechnology Sales Representative. To find the one nearest to you, go to www.apexanalog.com

IMPORTANT NOTICE

Apex Microtechnology, Inc. has made every effort to insure the accuracy of the content contained in this document. However, the information is subject to change without notice and is provided "AS IS" without warranty of any kind (expressed or implied). Apex Microtechnology reserves the right to make changes without further notice to any specifications or products mentioned herein to improve reliability. This document is the property of Apex Microtechnology and by furnishing this information, Apex Microtechnology grants no license, expressed or implied under any patents, mask work rights, copyrights, trademarks, trade secrets or other intellectual property rights. Apex Microtechnology owns the copyrights associated with the information contained herein and gives consent for copies to be made of the information only for use within your organization with respect to Apex Microtechnology integrated circuits or other products of Apex Microtechnology. This consent does not extend to other copying such as copying for general distribution, advertising or promotional purposes, or for creating any work for resale.

APEX MICROTECHNOLOGY PRODUCTS ARE NOT DESIGNED, AUTHORIZED OR WARRANTED TO BE SUITABLE FOR USE IN PRODUCTS USED FOR LIFE SUPPORT, AUTOMOTIVE SAFETY, SECURITY DEVICES, OR OTHER CRITICAL APPLICATIONS. PRODUCTS IN SUCH APPLICATIONS ARE UNDERSTOOD TO BE FULLY AT THE CUSTOMER OR THE CUSTOMER'S RISK.

Apex Microtechnology, Apex and Apex Precision Power are trademarks of Apex Microtechnology, Inc. All other corporate names noted herein may be trademarks of their respective holders.

X-ON Electronics

Largest Supplier of Electrical and Electronic Components

Click to view similar products for [Development Boards & Kits - Other Processors](#) category:

Click to view products by [Apex Microtechnology](#) manufacturer:

Other Similar products are found below :

[EVB-MEC1418MECC](#) [20-101-1252](#) [CC-ACC-18M433](#) [STM8S/32-D/RAIS](#) [RTK0EN0001D01001BZ](#) [MAXQ622-KIT#](#)
[YR0K50571MS000BE](#) [QB-R5F104PJ-TB](#) [CC-ACC-ETHMX](#) [OV-7604-C7-EVALUATION-BOARD](#) [SK-AD02-D62Q1747TB](#) [SK-BS01-D62Q1577TB](#) [ST7MDT1-EMU2](#) [GROVE BASE KIT FOR RASPBERRY PI](#) [CAB F-F\(40-17-RAINBOW\)](#) [CAB M-M\(40-17-RAINBOW\)](#)
[CY3280-MBR3](#) [CY8CKIT-143A](#) [CY8CPROTO-062-4343W](#) [RASPBERRY PI PICO](#) [EK-MPC5744P](#) [KITAURIXTC234TFTTOBO1](#)
[GENESYS ZU-5EV](#) [ENW89854AXKF](#) [ENWF9201AVEF](#) [QB-R5F104LE-TB](#) [LV18F V6 64-80-PIN TQFP MCU CARD EMPTY](#) [LV-24-33](#)
[V6 44-PIN TQFP MCU CARD EMPTY](#) [LV-24-33](#) [V6 64-PIN TQFP MCU CARD EMPTY](#) [LV-24-33](#) [V6 80-PIN TQFP 1 MCU CARD](#)
[EMPTY](#) [32X32 RGB LED MATRIX PANEL - 6MM PITCH](#) [3.3 - 5 VTRANSLATOR](#) [READY FOR XMEGA CASING \(WHITE\)](#) [RELAY4](#)
[BOARD](#) [ETHERNET CONNECTOR](#) [RFID CARD 125KHZ - TAG](#) [RFID READER](#) [RFM12B-DEMO](#) [MAROON](#) [3G CLICK \(FOR](#)
[EUROPE AND AUSTRALIA\)](#) [MAX232](#) [MAX3232 BOARD](#) [ARTY S7-50](#) [TINKERKIT HALL SENSOR](#) [TOUCHPANEL](#)
[TOUCHPANEL CONTROLLER](#) [MIKROBOARD FOR AVR WITH ATMEGA128](#) [MIKROBOARD FOR PSOC WITH CY8C27643](#)
[MIKROBUS CAPE](#) [MIKRODRIVE](#)