

Evaluation Kit

APPLICABLE PARTS (SOLD SEPARATELY)

- SA310KR

INTRODUCTION

This kit contains everything needed for rapid prototyping with the SA310KR 3-phase driver. With a multitude of circuit options, the EK76 offers versatility when it comes to connecting inputs, measuring outputs, and conditioning signals to the specific application environment. High- and low- input signals for each phase may be supplied from any 3 V to 18 V digital controller via standard pin header or SMA connectors. A removable 50 Ω termination resistor is offered for impedance-matched inputs. Coaxial measurement points are offered for high-fidelity waveform measurement, so erroneous overshoot/ringing are cut down to a minimum. The layout is carefully optimized for signal and power transmission, while permitting easy integration with system controllers and 3-phase loads.

ABSOLUTE MAXIMUM RATINGS

All specifications listed in the SA310 datasheet apply to this board, except as noted below. This board uses components that limit SA310's full operating range in exchange for convenience to the customer.

Parameter	Symbol	Max	Units	Limited By
Output Current, continuous, within SOA	I_{OUT}	20	A	DUT-socket
Power Dissipation, SA310	P_D	60	W	DUT-HS

Figure 1: Circuit Diagram

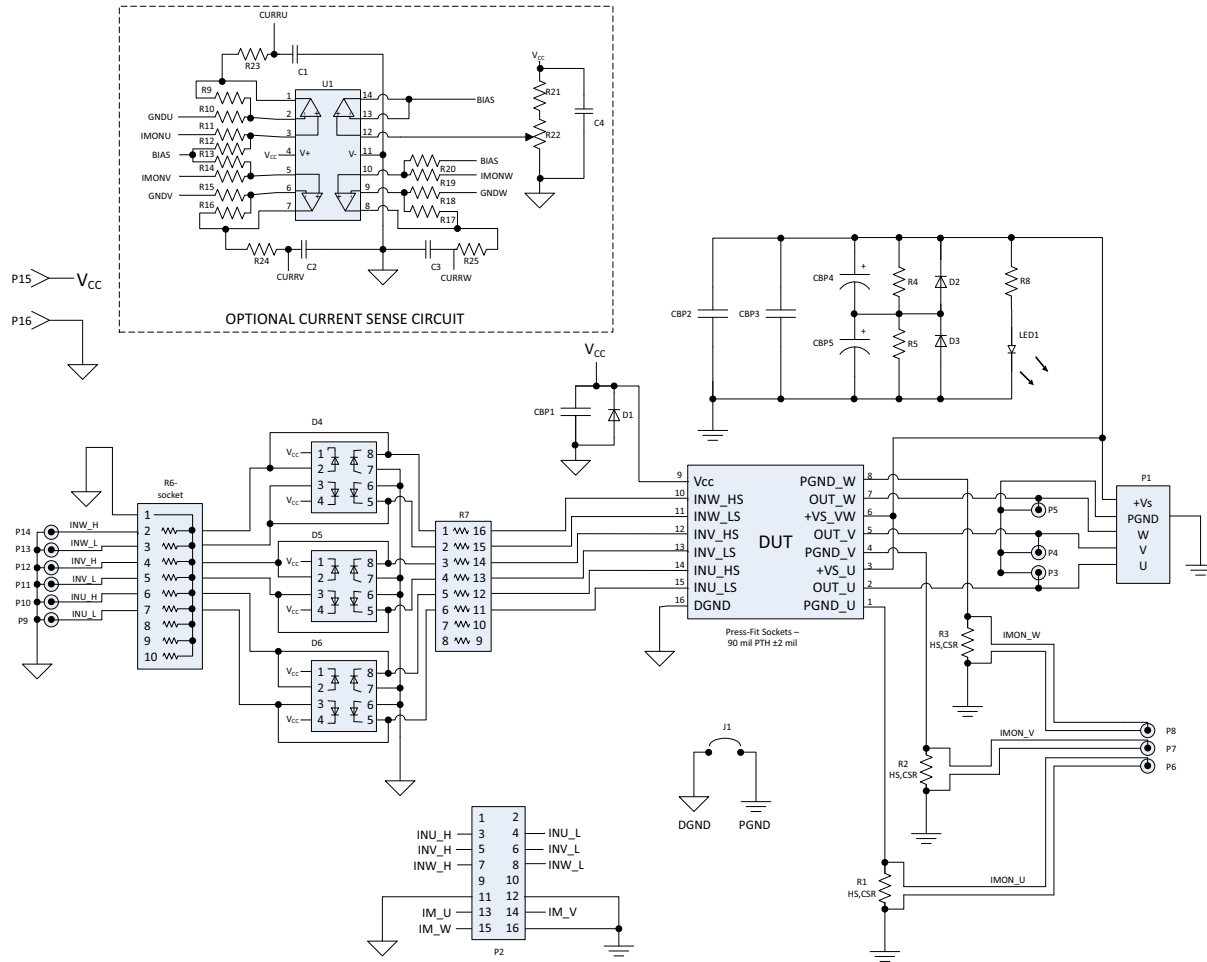

PARTS LIST

Reference	Manufacturer Part #	Description	QTY
<u>Printed Circuit Board</u>			
EVAL94	EVAL94	Printed Circuit Board	1
<u>Resistors</u>			
R1, 2, 3	CSR03	Res, 10mΩ, 16W, 5%, TO-220	3
R4,5	CFR-50JB-52-430K	Res, 430kΩ, 1/2W, 5%, Axial	2
R6	4610X-101-510LF	Res, 9 array, 51Ω, 0.2W, SIP	1
R6-socket	PPTC101LFBN-RC	SIP Socket, 10pin	1
R7	4116R-1-221LF	Res, 8 array, 220Ω, TH DIP	1
R8	RR03J150KTB	Res, 150kΩ, 3W, 5%, Axial	1
<u>Capacitors</u>			
CBP1	OX7RR105KWN	Ceramic Cap, 1 μF, 200V	1
CBP2, 3	2220Y1K00474KXTWS2	Ceramic Cap, 470nF, 1KV, X7R, 2220	2
CBP4, 5	380LX122M400A082	Electrolytic Cap, 1200μF, 400V	2
<u>Diodes</u>			
D1	P6KE27A-TP	TVS diode, 23.1V standoff, 5W	1
D2, 3	P6KE400A	TVS diode, 342V standoff, 5W	2
D4, 5, 6	UC3611N	Diode, 4 array, 50V, 3A	3
LED1	LTL2R3KRD-EM	LED, red, 2mA nominal	1
<u>Hardware</u>			
DUT-socket	6342-0-15-15-42-27-10-0	Pin Receptacle, 20A	16
P1	TS01	5-Block Terminal Strip	1
P2	M20-9980845	Pin header, 2 x 8, 0.1" pitch	1
P3, 4, 5	731711900	BNC connector, vertical, PC mount	3
P15, 16	571-0100	Banana Jack, horizontal, PC mount	2
DUT-HS	HS39	Heatsink, Power DIP, slotted, 1.7°C/W	1
CSR-HS	CR101-75AE	Heatsink, 3 x TO-220, clip-on	1
	CLA-TO-21E	Heatsink Cam Clips	3
DUT-TW	TW22	Thermal Washer, KR package	1
	94639A288	3/16" nylon spacer	6
	91841A007	#6-32 nut	6
	90272A151	#6-32 x 3/4" panhead screw	2
	90272A150	#6-32 x 5/8" panhead screw	4
	91735A190	#8-32 x 1/4" panhead screw	4
	2221	#8-32 x 2" standoff	4
	TFT20014NA005-6"	Teflon Tubing	1

Optional Components (Not Included)

P6-14	CON-SMA-EDGE-S	SMA Connector	9
U2	LM6134BIN/NOPB	Quad Op Amp, 14 DIP through hole	1
C1, 2, 3	-	CAP 0805 Not Populated	3
C4	C0805C104M5RACTU	CAP 0805 100nF 50V X7R	1
R9, 12, 13, 16, 17, 20	ERA-6AEB4992V	RES 0805 49.9kΩ 1/8W 0.1%	6
R10, 11, 14, 15, 18, 19	ERA-6AEB103V	RES 0805 10kΩ 1/8W 0.1%	6
R21	RMCF0805JT39K0	RES 0805 39kΩ 1/8W 5%	1
R22	3386P-1-103LF	Trimmer, 10kΩ, Through hole	1
R23, 24, 25	RMCF0805ZTOR00	RES 0805 0Ω Jumper	3

BEFORE YOU GET STARTED

- All Apex Microtechnology amplifiers should be handled using proper ESD precautions.
- Always use the heat sink included in this kit.
- Always use adequate power supply bypassing.
- Do not change the connections while the circuit is powered.
- Initially set all power supplies to the minimum operations levels allowed in the device data sheet.
- Check for oscillations.
- Please refer to Application Note, AN01 for general operating conditions.

ASSEMBLY INSTRUCTIONS

During the assembly, please refer to the circuit schematics, assembly drawings, and the data sheet of the part being used on the evaluation kit.

1. Note that each side of the EVAL94 circuit board is identified as either the Component side or the DUT (Device Under Test) side. The component side has the designators printed on that side.
2. First, insert the 16 pin receptacles from the DUT side, into the DUT position. These will be a tight fit, so a flat piece of metal is recommended as a finger-shield to fully engage the receptacles with the plated through-holes. This tight fit is meant to keep perpendicularity between the PCB and the pin direction. Ensure the hexagonal portions go completely through the holes, and the circular flange rests on the DUT side of the PCB. Solder the pin receptacles from the Component side.
3. Solder the surface-mount capacitors CBP1, CBP2, and CBP3 on the Component side.
4. If current-sense offset or gain adjustment is required, install the optional components U2 and surrounding resistors/capacitors. These components are not included, as this is only necessary in unique applications where current sense must be tightly managed. See "Current Sense" section below.
5. Install the smaller components, including R4-8, D1-6, LED1, and P2. Note that R6 includes a socket to easily swap between high-impedance inputs (R6 not installed) and 50-Ohm terminated inputs (R6 installed). Each element of this resistor can dissipate up to 200mW. Match the direction of R6 with the PCB designator when installing. Also match all diode orientations with their respective designators.
6. Use a piece of heavy wire (16 to 14 AWG, 1.3 to 1.8 mm) to short J1. This should be the only connection between digital ground (DGND) and power ground (PGND).
7. Install P3, P4, and P5 BNC connectors for output sense with an oscilloscope. This is best done by soldering the center pin first to anchor the component in place, then soldering the 4 external lugs.
8. Install R1, R2, and R3. Their heights must be set by the widened portion of the pins resting on the Component side of the PCB. This will place the plastic package 4mm above the PCB.
9. Apply a thin layer of thermal grease (not included) the backside of R1, R2, and R3. Place the CSR-HS (CR101-75AE; the smaller of the two included heatsinks) behind these resistors, with the mounting lugs engaging the PCB holes. Solder these mounting lugs while keeping the heatsink perpendicular to the board.
10. From either side, slide the cam clips (CLA-TO-21E) into the hooked slot of the CSR-HS. The tabs should be pointed at a 45° angle down and away from the heatsink. Once the clip is in front of a resistor, flip the tab all the way up to apply pressure to each resistor.
11. Install P1, P15, and P16.
12. Install electrolytic bypass capacitors CBP4 and CBP5, ensuring that the orientation matches the circuit schematic drawing.
13. P6 through P14 have edge-connector pads. These pads are designed for edge-mount SMA connectors (not included). If SMA connection is not desired, leave these pads unpopulated. Otherwise, use recommended part number CON-SMA-EDGE-S (or similar) and solder these to the board.

14. Make sure all leads protruding out the DUT side are clipped to under 1/8 inch (3mm).
15. When installing the DUT-HS, start by temporarily fastening the central 2 holes to the board. Pass the #6-32 x 3/4" screws through the heatsink and place a nylon spacer on each. Carefully pass this assembly through the matching holes on the PCB and fasten with #6-32 nuts on the component side.
16. Now, make a similar assembly at each corner of the heatsink. Pass the #6-32 x 5/8" screws through the heatsink while holding a nylon spacer between the board and heatsink (pliers would be helpful). Fasten with #6-32 nuts on the component side and tighten.
17. Undo the first two screws and nuts, but leave the nylon spacers sandwiched between the heatsink and board.
18. Cut the Teflon tubing into 1/4 inch (6mm) pieces and slide the pieces onto the pins of the DUT. This is an added precaution to prevent the heatsink or thermal washer from shorting against the pins. One sleeve on each of 4 corners of the DUT is sufficient. Do not cut Teflon longer than the recommended length, as this will prevent proper seating of the DUT on the heatsink.
19. Place a single TW22 thermal washer over the heatsink area where the DUT will go. Place the DUT in this space, so its pins pass through the TW22 and the heatsink slots. Rest the pins over the pin receptacles from step 2. Engaging all 16 receptacles requires much force. Rather than applying this force by hand, reinstall the #6-32 x 3/4" screws and nuts, this time passing through the DUT tabs and TW22. With the #6-32 nut on the component side, tighten the screws in small increments, switching frequently between the two screws. Make sure the TW22 is loose and centered up until the final tightening, or else the metallic foil can short out the DUT's pins.
20. Use the #8-32 x 1/4" screws to mount a 2-inch standoff on each corner of the PCB.

HEATSINK GUIDELINES

Determining heatsink size for SA310 depends on several factors. Refer to SA310 datasheet for more information on calculating power dissipation, thermal resistance, and finding thermal ratings.

MOTOR CONTROL

P2 is designed to match the "remote amplifier" connector on Precision Motion Device's DK78113 developer kit for the Juno Velocity & Torque Control IC. Follow the instructions in the DK78113 User Manual to connect a remote amplifier. Applications requiring torque control will require the Current Sense gain and offset circuit described below. Use default values when pairing with the Juno device.

Other motor control ICs may be used with EK76, but these may require different wiring and/or current sense circuits.

CURRENT SENSE

The optional current sense gain and offset circuit is designed to interface with various ADCs in closed-loop current/torque control. Follow the below schematic and equations to determine the proper component values.

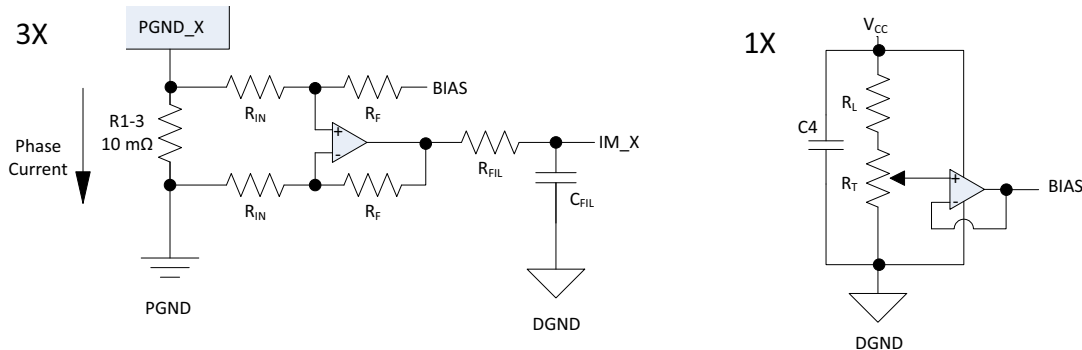

Value	Applicable Designators on EVAL94	Equation	Default Value	Units	Suggested Tolerance
V _{OS}	Bias	ADC min input (or higher)	1.65	V	-
V _{OUT_MAX}	-	ADC max input (or lower)	3.3	V	-
I _{OUT_MAX}	-	< 80 A	33	A	-
Gain	-	$(V_{OUT_MAX} - V_{OS}) / (I_{OUT_MAX} * 10 \text{ m}\Omega)$	5	V/V	-
R _F	R9, 12, 13, 16, 17, 20	$1.8\text{k} < R_F < 100\text{k}$	50k	Ω	0.1%
R _{IN}	R10, 11, 14, 15, 18, 19	R_F / Gain	10k	Ω	0.1%
R _T	R22 (potentiometer)	$1\text{k} < R_T < 100\text{k}$	10k	Ω	-
R _L	R21	Roughly $R_T((V_{CC}/2V_{OS}) - 1)$	39k	Ω	-
C4	C4	$C4 = 100\text{n}$	100n	F	X7R
f _{FIL}	-	Typically $200\text{k} < f_{FIL} < 1\text{M}$	∞	Hz	-
R _{FIL}	R23, 24, 25	Typically $100 < R_{FIL} < 1\text{k}$	0	Ω	-
C _{FIL}	C1, 2, 3	$1 / (2\pi * f_{FIL} * R_{FIL})$	0	F	-

After assembly of the EK76 including the above Current Sense circuit, R22 must be trimmed to reach the desired value of V_{OS}. To do this, attach a Voltmeter to measure the voltage between pins 11 (negative) and 13 (positive) of P2. Apply the low-voltage supply VCC (+VS should NOT be active). Adjust R22 until the desired value for V_{OS} is shown on the Voltmeter.

The following equation represents the Low-Side Phase Current (I_{PHASE}) as a function of voltage measured at IM_X (V_M):

$$I_{PHASE} = \frac{V_M - V_{OS}}{\text{Gain} \cdot 0.01\Omega}$$

Figure 2: Top View

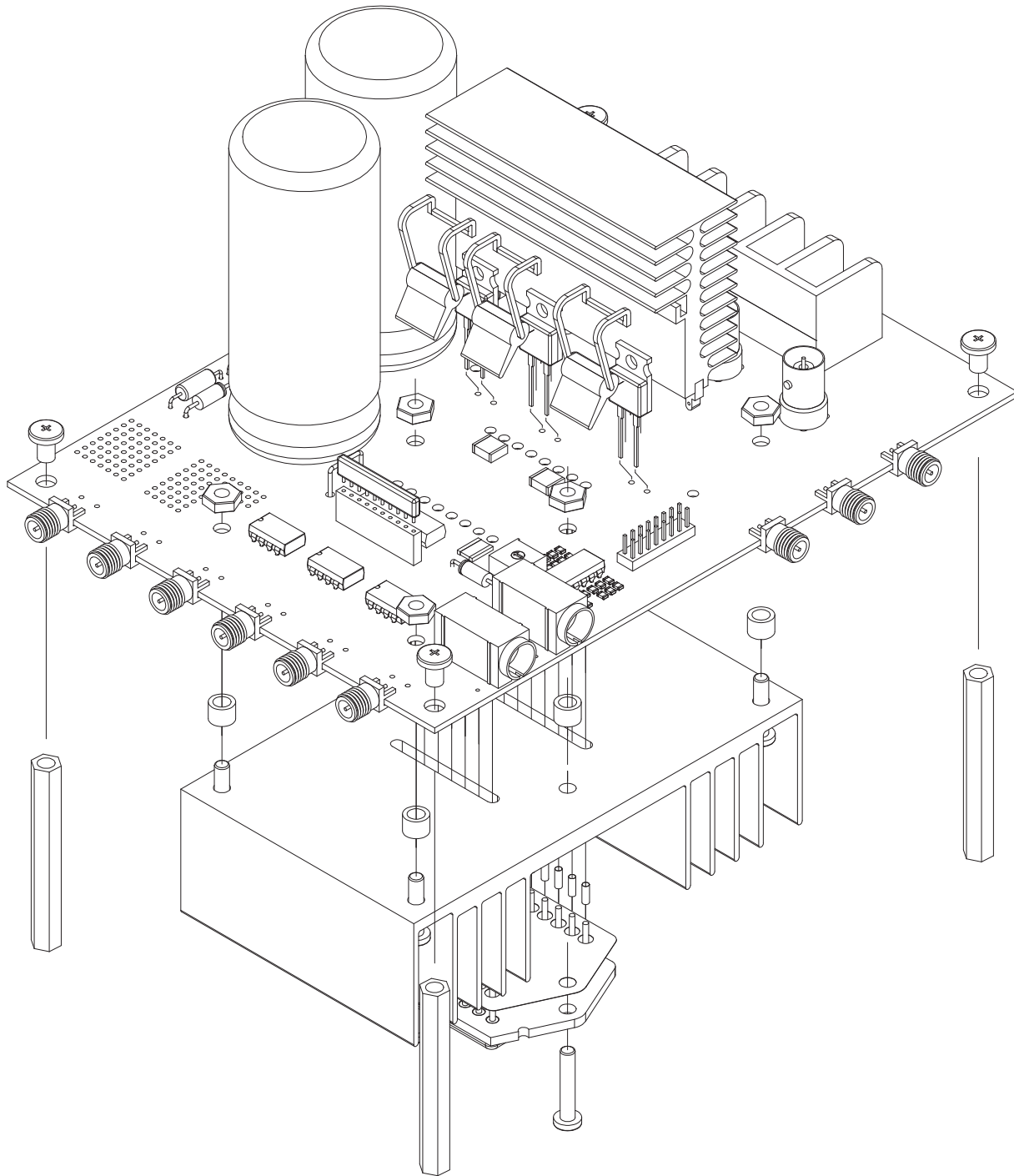
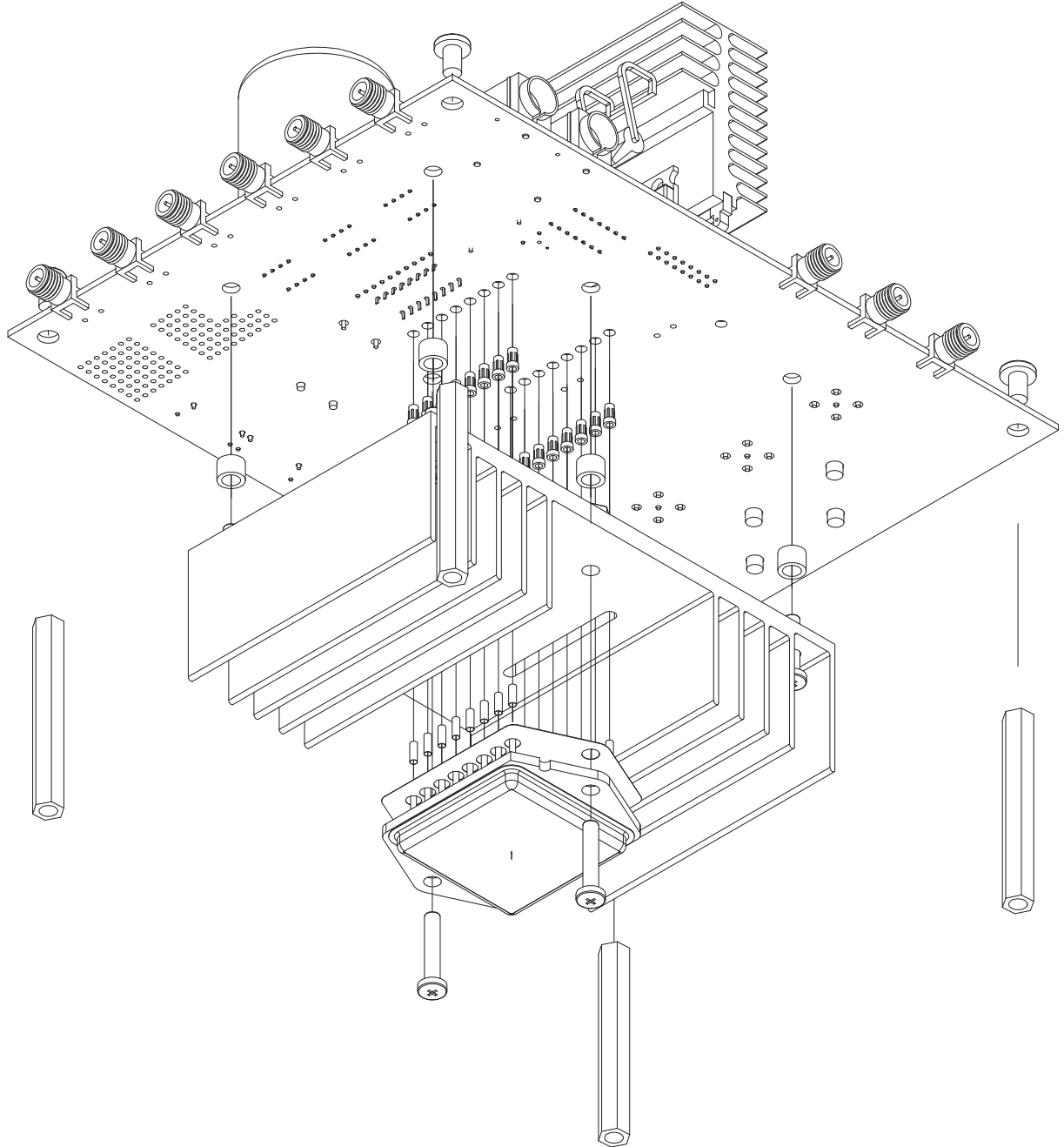

Figure 3: Bottom View



TEST ASSEMBLY

EQUIPMENT NEEDED

1. Power Supplies
2. Digital Controller or 6+ Channel Pattern Generator
3. Oscilloscope
4. Proper Heatsinking System

TEST SETUP

Make sure all supplies are turned off before connection. Connect the power supplies V_{CC} (via P15 and P16) and $+V_S$ (via P1). See SA310 datasheet for acceptable voltage levels. The $+V_S$ LED will be visibly bright for voltages 30V and above. For lower voltages, consider using a smaller-value resistor for R8.

When sequencing power supplies, use the following order:

Power ON: V_{CC} , then $+V_S$

Power OFF: $+V_S$, then V_{CC}

It is recommended to first test the device with no load attached. Ensure the output waveform follows the expected results before connecting a load. Consider power dissipation in the amplifier, sense resistors, and the load.

The BNC connectors P3, P4, and P5 are designed for coaxial measurement of the output; these are not meant to carry significant current. **ONLY USE P1 FOR HIGH-CURRENT CONNECTIONS.** To use P3-P5, for voltages within the oscilloscope's input rating, BNC cables may be used to connect directly to the oscilloscope. For higher voltages, use a high-voltage oscilloscope probe with a probe-tip-to-BNC adapter. Alternatively, use high-voltage BNC attenuators in series with the BNC cable.

NEED TECHNICAL HELP? CONTACT APEX SUPPORT!

For all Apex Microtechnology product questions and inquiries, call toll free 800-546-2739 in North America. For inquiries via email, please contact apex.support@apexanalog.com. International customers can also request support by contacting their local Apex Microtechnology Sales Representative. To find the one nearest to you, go to www.apexanalog.com

IMPORTANT NOTICE

Apex Microtechnology, Inc. has made every effort to insure the accuracy of the content contained in this document. However, the information is subject to change without notice and is provided "AS IS" without warranty of any kind (expressed or implied). Apex Microtechnology reserves the right to make changes without further notice to any specifications or products mentioned herein to improve reliability. This document is the property of Apex Microtechnology and by furnishing this information, Apex Microtechnology grants no license, expressed or implied under any patents, mask work rights, copyrights, trademarks, trade secrets or other intellectual property rights. Apex Microtechnology owns the copyrights associated with the information contained herein and gives consent for copies to be made of the information only for use within your organization with respect to Apex Microtechnology integrated circuits or other products of Apex Microtechnology. This consent does not extend to other copying such as copying for general distribution, advertising or promotional purposes, or for creating any work for resale.

APEX MICROTECHNOLOGY PRODUCTS ARE NOT DESIGNED, AUTHORIZED OR WARRANTED TO BE SUITABLE FOR USE IN PRODUCTS USED FOR LIFE SUPPORT, AUTOMOTIVE SAFETY, SECURITY DEVICES, OR OTHER CRITICAL APPLICATIONS. PRODUCTS IN SUCH APPLICATIONS ARE UNDERSTOOD TO BE FULLY AT THE CUSTOMER OR THE CUSTOMER'S RISK.

Apex Microtechnology, Apex and Apex Precision Power are trademarks of Apex Microtechnology, Inc. All other corporate names noted herein may be trademarks of their respective holders.

X-ON Electronics

Largest Supplier of Electrical and Electronic Components

Click to view similar products for [Power Management IC Development Tools](#) category:

Click to view products by [Apex Microtechnology](#) manufacturer:

Other Similar products are found below :

[EVB-EP5348UI](#) [MIC23451-AAAYFL EV](#) [MIC5281YMME EV](#) [124352-HMC860LP3E](#) [DA9063-EVAL](#) [ADP122-3.3-EVALZ](#) [ADP130-0.8-EVALZ](#) [ADP130-1.8-EVALZ](#) [ADP1740-1.5-EVALZ](#) [ADP1870-0.3-EVALZ](#) [ADP1874-0.3-EVALZ](#) [ADP199CB-EVALZ](#) [ADP2102-1.25-EVALZ](#) [ADP2102-1.875EVALZ](#) [ADP2102-1.8-EVALZ](#) [ADP2102-2-EVALZ](#) [ADP2102-3-EVALZ](#) [ADP2102-4-EVALZ](#) [AS3606-DB](#) [BQ25010EVM](#) [BQ3055EVM](#) [ISLUSBI2CKIT1Z](#) [LM2734YEVAL](#) [LP38512TS-1.8EV](#) [EVAL-ADM1186-1MBZ](#) [EVAL-ADM1186-2MBZ](#) [ADP122UJZ-REDYKIT](#) [ADP166Z-REDYKIT](#) [ADP170-1.8-EVALZ](#) [ADP171-EVALZ](#) [ADP1853-EVALZ](#) [ADP1873-0.3-EVALZ](#) [ADP198CP-EVALZ](#) [ADP2102-1.0-EVALZ](#) [ADP2102-1-EVALZ](#) [ADP2107-1.8-EVALZ](#) [ADP5020CP-EVALZ](#) [CC-ACC-DBMX-51](#) [ATPL230A-EK](#) [MIC23250-S4YMT EV](#) [MIC26603YJL EV](#) [MIC33050-SYHL EV](#) [TPS60100EVM-131](#) [TPS65010EVM-230](#) [TPS71933-28EVM-213](#) [TPS72728YFFEVM-407](#) [TPS79318YEQEV](#) [ISL85033EVAL2Z](#) [UCC28810EVM-002](#) [XILINXPWR-083](#)