

## Evaluation Kit

### APPLICABLE PARTS (SOLD SEPARATELY)

- PA22LL

### INTRODUCTION

This kit contains everything needed for rapid prototyping with the PA22LL Operational Amplifier. The EK79 offers versatility when it comes to connecting inputs, measuring outputs, and conditioning signals to the specific application environment. An additional prototyping area makes it possible to analyze a multitude of standard or proprietary circuit configurations. On board temperature sensing terminals allow for real time output stage junction temperature monitoring. EK79 also provides flexibility for modifying the gain, in inverting or non-inverting mode as well as an optional Improved Howland Current Pump configuration feature.

### ABSOLUTE MAXIMUM RATINGS

All specifications listed in the PA22LL datasheet apply to this PCB.

Figure 1: PCB Layout

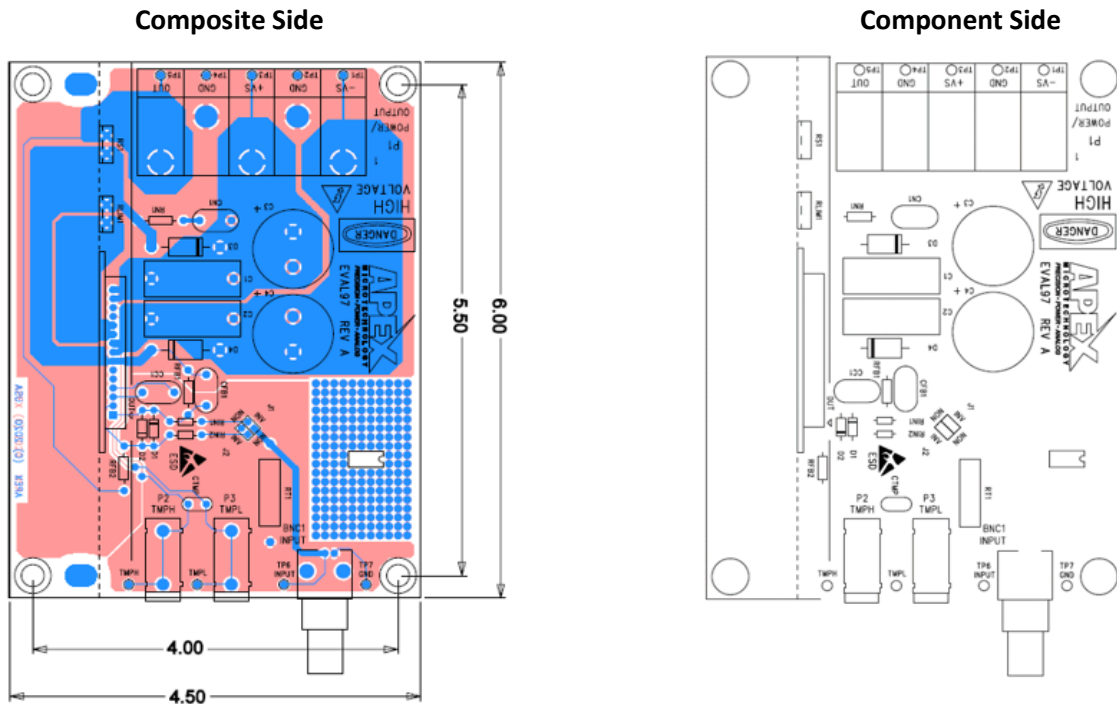

Top Metal Layer

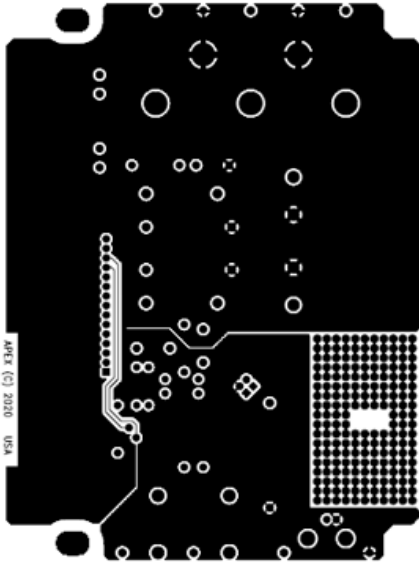

Bottom Metal Layer

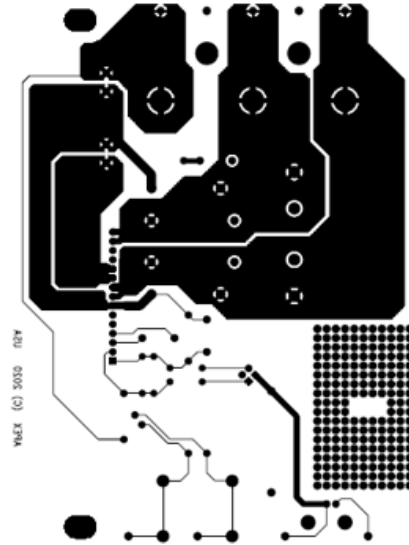
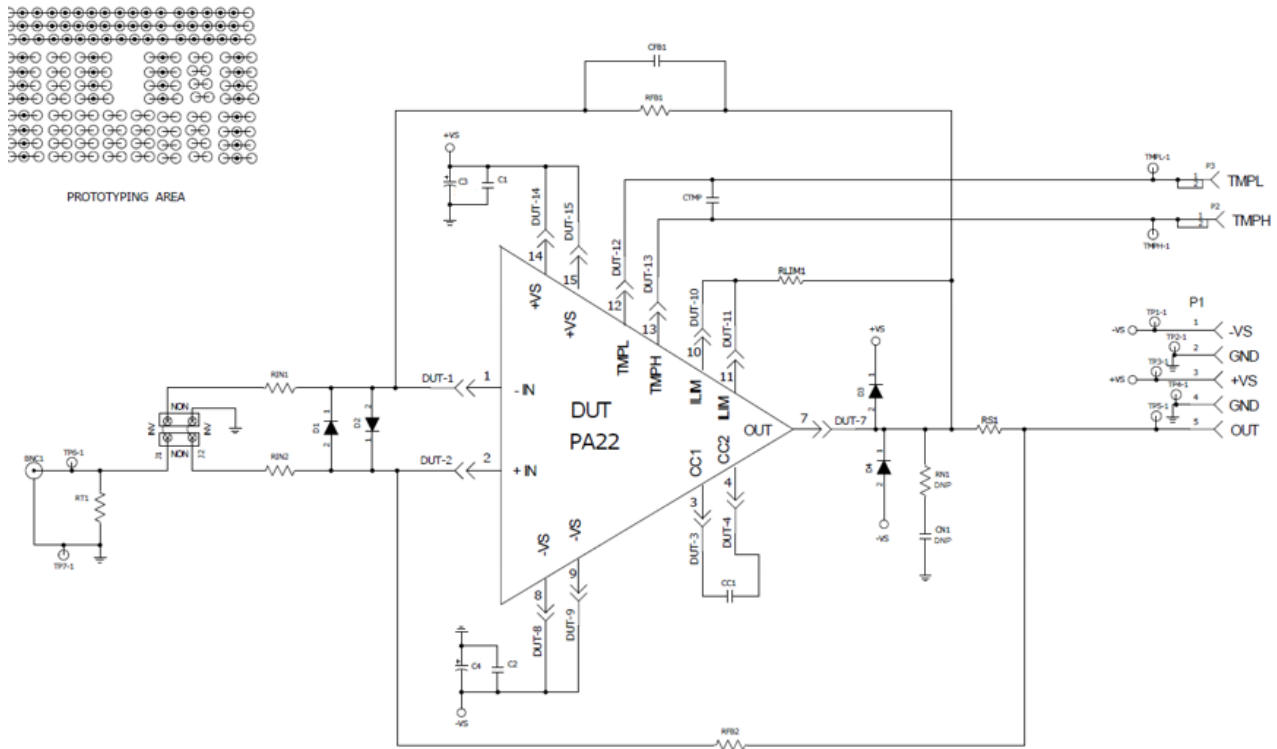

Figure 2: Circuit Diagram



**PARTS LIST**

Reference	Manufacturer Part #	Description	QTY
<b><u>Printed Circuit Board</u></b>			
EVAL97	EVAL97	Printed Circuit Board	1
<b><u>Resistors</u></b>			
RT1	PR03000205109JAC00	51Ω 3W Axial Resistor	1
RIN1, RIN2	SFR16S0004750FR500	RES, 475Ω, 1/2W, 1%, TH	2
RFB1, RFB2	CMF5549K900FHEB	RES, 49.9K,1/2W,1%, TH	1
RLIM1	CSR06	0.2Ω MP930 30W TO-220 Res.	1
<b><u>Capacitors</u></b>			
C1, C2	QXP2E105KRPT	1 μF 250V PP cap	2
C3, C4	EKM401VSN121MP30S	120 μF 400V Electrolytic	2
CC1	CC45SL3AD470JYVNA	CAP CER 47PF 1KV RADIAL	1
CTMP1	C322C471J2G5TA7301	CAP CER 470PF 200V COG/NP0 RAD	1
<b><u>Diodes</u></b>			
D1, D2	1N4148-T	1N4148 75V Diode	2
D3, D4	MUR440G	MUR440 400V 4A Diode	2
<b><u>Hardware</u></b>			
J1, J2	PRPC002SAAN-RC	pin header 2x1	2
J1, J2-covers	SPC02SVJN-RC	shorting jumper	2
BNC1	146510CJ	BNC Connector, right angle	1
P1	TS01	5-terminal strip	1
P2, P3	571-0100	4MM BLACK PCB SOCKET	2
HS1	HS32	Heatsink Clip-on 1.33 °C/W	1
HS1-clips	CLAMP05	Clamp for HS32	4
DUT1-socket	8637-0-15-15-21-27-10-0	Cage Jacks, 0.019" pin diameter	18
HS1-fasteners	92005A218	Panhead Screw M4 x 8mm	2
Standoffs	2221	Hex Standoff #8-32 x 2"	4
Standoffs-fasteners	91735A190	Panhead Screw #8-32 x 0.25"	4
Thermal Washer	TW15	Thermal Washer, LL Package, pack of 10	1

**Table 1** identifies the components that should be installed in the schematic for a particular EK79 configuration. The top row lists all the possible configurations. The letter 'X' indicates components which are common to all configurations. The symbol '✓' indicates the specific type of component to be selected from the parts list above. The parts list shows all the components that are supplied with the kit.

Table 1:

	Voltage Mode (Default)	Howland Pump
RFB2, CFB1(optional)		✓
RS1	Isolation Resistor or Short with Wire	Sense Resistor
CC1		X
RLIM1		X
RT1		X
J1, J2		X
RIN1, RIN2		X
D1, D2, D3, D4		X
C1, C2, C3, C4		X

## BEFORE YOU GET STARTED

- All Apex Microtechnology amplifiers should be handled using proper ESD precautions.
- Always use the heat sink included in this kit.
- Always use adequate power supply bypassing.
- Do not change the connections while the circuit is powered.
- Initially set all power supplies to the minimum operations levels allowed in the device data sheet.
- Check for oscillations.
- Please refer to Application Note, AN01 for general operating conditions.

## ASSEMBLY INSTRUCTIONS

During the assembly, please refer to the circuit schematics, assembly drawings, and the data sheet of the part being used on the evaluation kit.

1. The top side of the Eval97 has designators printed near all component locations as well as input/output terminals.
2. All the components should be installed on the top side of the board near their associated designator and soldered in.
3. First, insert 15 pin receptacles of the **DUT1-socket** (cage jacks) into the DUT pin positions. These will be a somewhat loose fit until they are soldered in, so a flat piece of metal is recommended as a finger-shield to fully engage the receptacles with the plated through-holes. This piece of metal (or any flat surface object that can conveniently press against pin receptacles) is meant to keep perpendicularity between the PCB and the pin direction. Ensure the hexagonal portions go completely through the holes, and the circular flange rests on the top side of the PCB. Solder the pin receptacles from the bottom side of the PCB preferably as attempting to solder from the top side can render the receptacles unusable if they get solder inside them. There is much less chance of this happening when soldering from the bottom because the pin receptacles extend out beyond the bottom edge of the board to a point that makes it difficult to get solder inside when using a solder iron to attach the receptacles to the PCB.
4. After cage jacks have been soldered in, continue by installing all the of the smaller sized through-hole components on the board. This should include all of the axial style components: **RT1, RIN1, RIN2, RFB1 (RN1, RS1 & RFB2** if applicable) and **D1-D4**. This is a logical practice as it becomes difficult to properly seat a smaller profile component on the board once any larger profile component has been installed. It is also useful to place all components with their printed value facing up, if possible, as well as in the same orientation as their nearby designator printed on the PCB. This same convention also needs to be followed with any diode installation because they are a unidirectional component that will not function correctly if installed in reverse configuration. Note: If Howland Current Pump configuration is not being utilized and no isolation resistance between op amp circuit and output is required, a shorting wire can be installed across RS1.
5. Next, all medium profile radial style components should be installed (**RLIM1** will be discussed in later step). These include pin headers **J1, J2**, compensation capacitor **CC1** and temperature sense capacitor **CTMP1 (CFB1 & CN1** if applicable). Be careful to solder pin headers **J1** and **J2** to the PCB as close to perpendicular as possible to ensure ease of **J1 and J2 shorting cover** installation and removal when varying input configuration.
6. Now that most of the small to medium sized components have been placed, it is time to mount the BNC input connector, Power supply terminals and Temperature sensing cable jacks along with the remaining large sized capacitors **C1-C4**. Order of connector installation should proceed as follows: The 4MM PCB sockets **P2** and **P3** install primarily, followed by the 5 terminal strip for P1 and finally the Right angle BNC connector for **BNC1**.

7. **C1-C4** are the largest profile components included in the kit and therefore should be installed after all other components so that they don't obstruct or needlessly complicate the placement of smaller profile components. Order of capacitor installation should proceed as follows: **C1** and **C2** should install primarily followed by the electrolytic **C3** and **C4** capacitors, ensuring that the orientation of **C3** and **C4** matches the polarity marks that are printed on the top side of the PCB.
8. At this point, the only components left to install should be those that require a heatsink attachment and any accompanying hardware and fasteners. The components RLIM1 and RS1(optional) will be soldered into the PCB as well as attached to the heatsink. This requires that they first be clipped into the heatsink HS1 (HS32) using the supplied HS1-clips (CLAMP05) to get an idea of how far the leads must be inserted through the PCB (prior to soldering) in order to be properly secured for maximum thermal conductivity through the heat tab to the heatsink. A couple simple ways to do this would be either by marking the leads at the specific depth they need to be inserted before removing the heatsink and soldering to PCB, or by placing a small solder tack weld on the resistor leads when they are inserted to the proper depth before removing the heatsink and soldering to PCB (WARNING: Attempting to solder the resistive components to the PCB while they are attached to the heatsink is not recommended as it may prove difficult to supply enough heat to melt solder fully while the devices are attached to such a large thermal load). This technique is meant to prevent RLIM1 and/or RS1 from being soldered too deeply into the PCB such that the CLAMP05 heatsink clips aren't able to reach the center of the T0-220 package that RLIM1 and RS1 are housed in. The clips should reach near the center of the package to ensure full contact between the face of heatsink and rear face of T0-220 package heat tab. Additionally, if needed, the pins of the T0-220 package can be carefully bent to ensure flush mounting of the back of the T0-220 package to the HS32 heatsink. You should find that when properly aligned, the edges of the heatsink are flush with the edges of the PCB board that are in proximity. This is illustrated in **FIGURE 3** below.
9. Applying a thin layer of thermal grease (not included) to the backside of RLIM1 and RS1 is also recommended to facilitate as much thermal conductivity as possible. Thermal grease should be applied subsequent to soldering the resistors into the PCB to reduce the chance of spreading any on your garments or the surrounding circuitry.
10. Once RLIM1 and/or RS1 have been installed, the PA22LL can now be clipped into the area slightly right of center on the **HS32** heatsink, when looking from top down. Be sure to affix a **TW15 thermal washer** to the heat tab of the PA22LL before placing it on the heatsink and clipping it in. You will find that it may take a few attempts at aligning the PA22LL in the heatsink so that it fits into the installed cage jack sockets and so that the **HS32** also sits flush with the edges of the PCB and doesn't hang over either side too much.
11. Heatsink clips **HS1-clips** can either be snapped into place from the front or slid in between the HS32 fins from either side. You want to be sure that the clip is placed centrally with relation to the component that needs pressure applied (i.e. the center of the PA22LL, RLIM1 or RS1). Clip placement is illustrated in **FIGURE 3** below.
12. Make sure all leads of soldered components that may be protruding out of the DUT side are cut to under 1/8 inch (3mm).
13. After clipping PA22LL into the HS32 heatsink, inserting the PA22LL into the PCB socket and finally clipping RLIM1 and/or RS1 to the heatsink, you are ready to fasten the HS32 heatsink to the PCB with the supplied **Panhead screws M4 x 8mm**. Once mounted, the threaded groove running along the bottom side of the HS32 heatsink will align with the holes directly beneath it on the PCB. Carefully screw the **HS1 fasteners** (Panhead Screws) through the holes into the bottom of the HS32 heatsink. A snug hand tightening of these screws is acceptable as over-tightening may cause stripping of the threads inside the heatsink.
14. Use the **Standoff Fasteners** (#8-32 x 1/4" screws) to mount the supplied 2-inch **Standoffs** (Hex Standoff #8-32 x 2") on each corner of the PCB.
15. The assembly of the EK79 is now complete and you should be ready to move on to power up and test.

**HEATSINK MOUNTING/PART MATING GUIDELINES**

The DUT (device under test), in this case the PA22LL, along with RLIM1 and RS1(if applicable) should always be clipped into the HS32 heatsink during power up and operation of the EK79.

**Figure 3:**

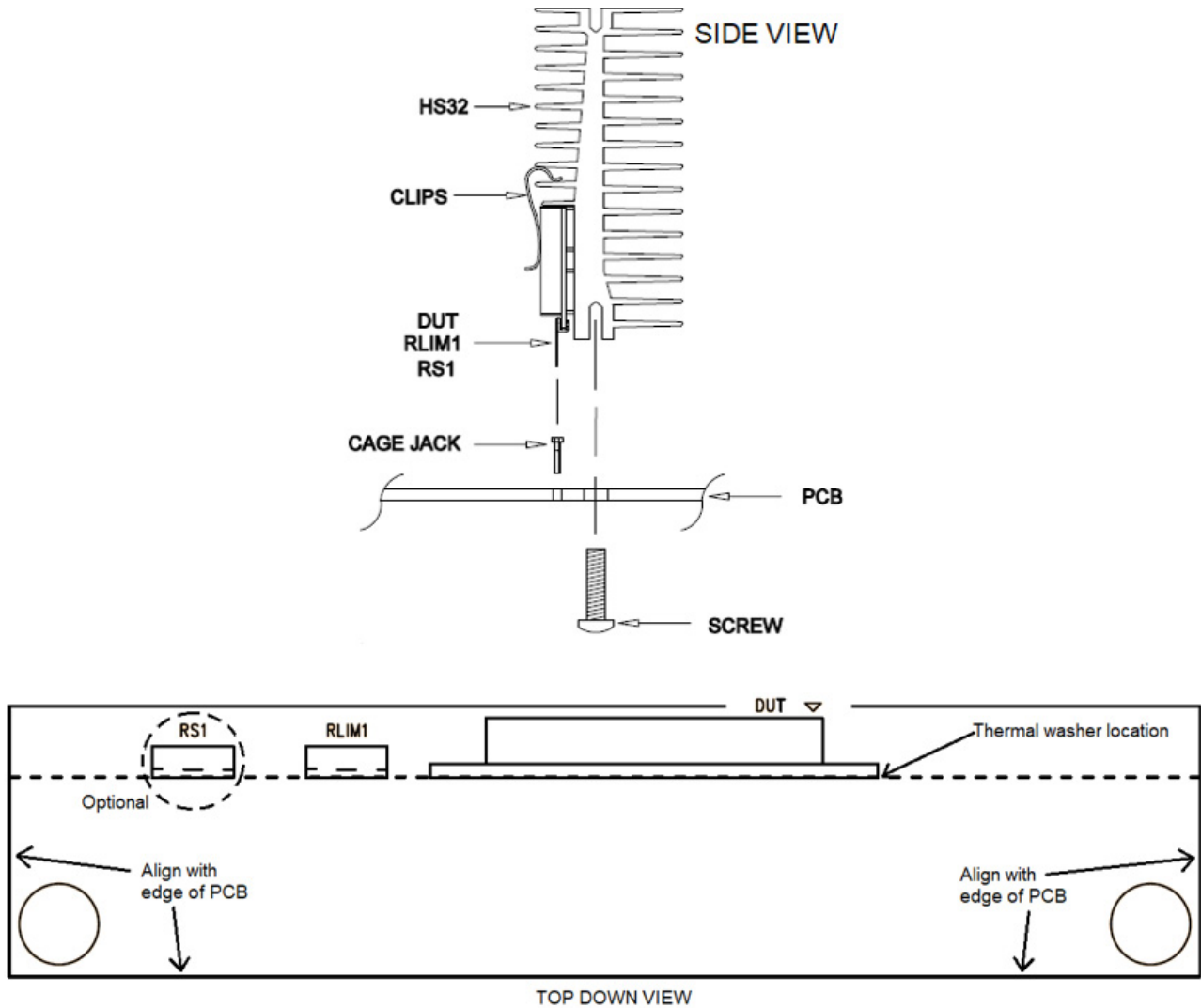

**INVERTING CONFIGURATION**

In order to operate in Inverting configuration, the **J1 and J2 shorting covers** need to be placed in parallel with the silkscreen markings on the PCB that indicate inverting configuration (**INV**) (45 degree CW orientation from vertical). This effectively shorts the non-inverting input to ground and connects the inverting input to the BNC signal input.

**Figure 4: Simplified Inverting Configuration Schematic**

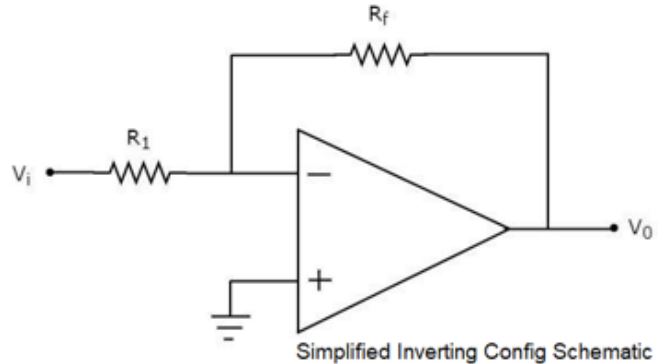

**NON-INVERTING CONFIGURATION**

In order to operate in Non-inverting configuration, the **J1 and J2 shorting covers** need to be placed in parallel with the silkscreen markings on the PCB that indicate non-inverting configuration (**NON**) (45 degree CCW orientation from vertical). This effectively shorts the inverting input to ground and connects the non-inverting input to the BNC signal input.

**Figure 5: Simplified Non-Inverting Configuration Schematic**

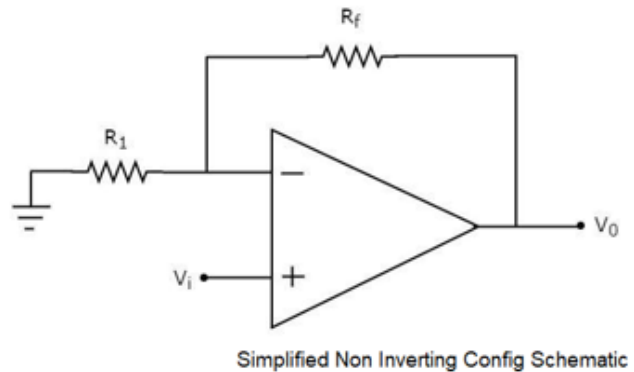



## PHASE COMPENSATION

The external compensation capacitor  $C_C$  is connected between pins 3 and 4. Unity gain stability can be achieved with any capacitor value larger than 220pF for a minimum phase margin of 45° driving resistive loads. At higher gains, more phase shift can usually be tolerated, and the compensation capacitor value can be reduced to result in higher bandwidth and slew rate. Use the typical operating curves as a guide to select  $C_C$  for the application. An NPO (COG) type capacitor rated for the full supply voltage (250V) is required.

Gain (V/V)	Suggested $C_{COMP}$ (pF)	Typical Slew Rate (V/ $\mu$ s)
$\geq 64$	3.3	123
$\geq 16$	12	95
$\geq 4$	47	35
$\geq 2$	100	16
$\geq 1$	220	8

## TEMPERATURE SENSE

PA22 offers accurate junction-temperature sense. This uses two parallel bipolar transistors mounted directly on top of select power die for near-junction temperature measurement. Connect pins 12 and 13 to the D- and D+ pins of LTC2997 (or similar device), respectively. The LTC2997 will properly bias the bipolar transistors and translate the signal to a Proportional To Absolute Temperature (PTAT) voltage. Apex does not recommend reading temperature without an LTC2997 or similar device.

## 'IMPROVED' HOWLAND CURRENT PUMP OPERATION

When using the PA22LL in an Improved Howland Current Pump configuration, the optional components (**RFB2**, **RS1**, **CFB1**) listed in the far right column of **TABLE 1** need to be purchased and installed according to assembly instructions.

If wanting to utilize the Howland Current Pump configuration, it would be advantageous to purchase closely matched components on the order of 0.01%. These components include **RIN1**, **RIN2**, **RFB1** and **RFB2** specifically. Extremely close resistor value matching is critical if gain accuracy is a concern because even resistors that have as little as 1% tolerance can result in a worst case large magnitude gain error. Please refer to Apex Application Note AN13 for further explanation.

The 'Improved' Howland Current Pump configuration allows for better output swing than the Basic Howland Current Pump. The current gain is set by **RS1**, modified by the ratio of **RIN1/RFB1** (which is typically 1/1). Consequently, you can use low values for **RS1** and keep all the other resistors high in value, such as 50k or 1 Megaohm. In the "Improved" Howland, note that it is not just the ratio of **RIN2/RFB2** that must match **RIN1/RFB1**; it is the ratio **RIN1 / (RFB2 + RS1)** that must be equal to **RIN1/RFB1**. If you do the intuitive analysis as mentioned above, you can see that if **RIN1 = RFB1**, **RFB2** will normally be **(RIN1 - RS1)**. Please refer to Apex Application Note AN13.

Figure 6:

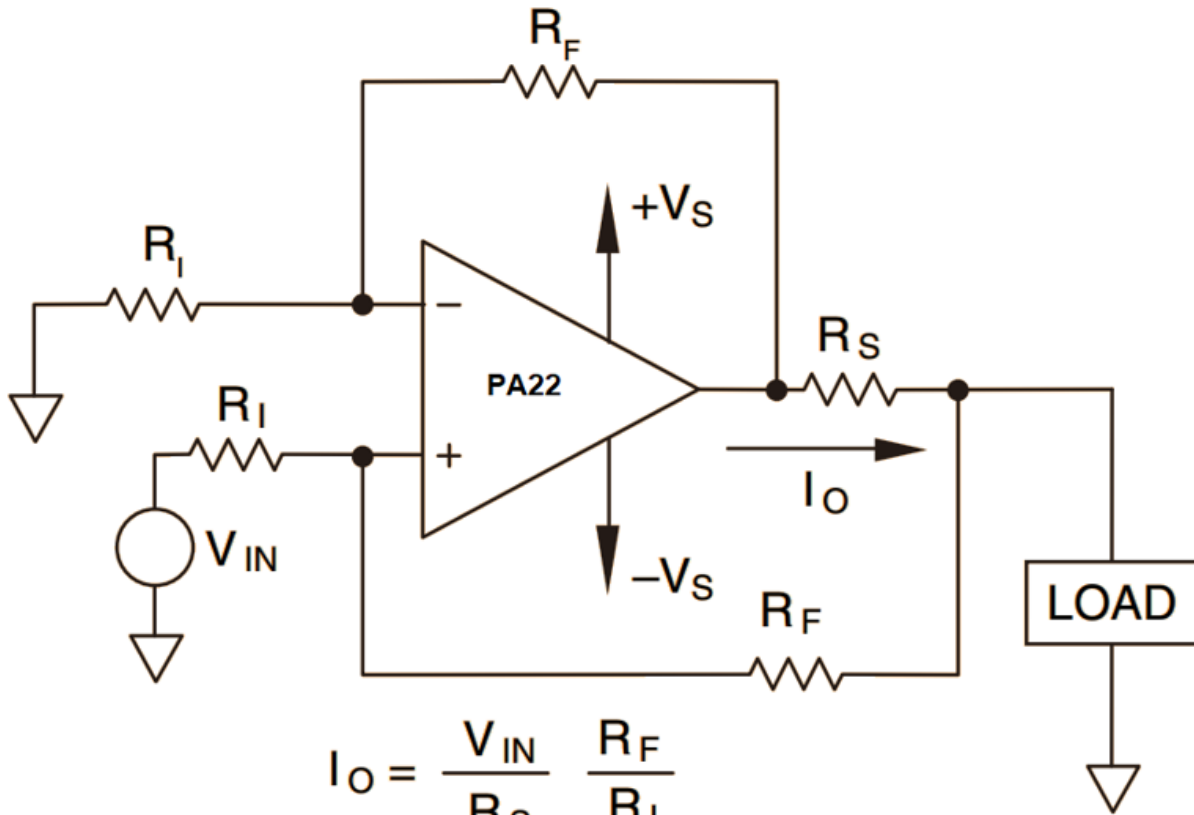

$$I_O = \frac{V_{IN}}{R_S} \frac{R_F}{R_I}$$

FOR:  $R_S \ll R_F$  or  $R_I$

---

## **TEST ASSEMBLY**

### ***EQUIPMENT NEEDED***

1. Power Supplies
2. Digital Multimeter
3. Oscilloscope
4. Proper Device Heatsinking

## **TEST SETUP**

Make sure all supplies are turned off before connection to the EK79. Connect the power supplies  $-V_S$  and  $+V_S$  (via P1). See PA22 datasheet for acceptable voltage levels. Both negative and positive power supplies should be powered on simultaneously.

It is recommended to first test the device with no load attached. It is always prudent to ensure that the output waveform conforms to the expected results based on the input waveform before connecting anything externally to the output of the EK79. Consider power dissipation in the amplifier, sense resistors, and the load. Once proper operation of the EK79 is confirmed with the PA22LL, then any external output loads should be connected.

---

## **NEED TECHNICAL HELP? CONTACT APEX SUPPORT!**

For all Apex Microtechnology product questions and inquiries, call toll free 800-546-2739 in North America. For inquiries via email, please contact [apex.support@apexanalog.com](mailto:apex.support@apexanalog.com). International customers can also request support by contacting their local Apex Microtechnology Sales Representative. To find the one nearest to you, go to [www.apexanalog.com](http://www.apexanalog.com)

---

### **IMPORTANT NOTICE**

Apex Microtechnology, Inc. has made every effort to insure the accuracy of the content contained in this document. However, the information is subject to change without notice and is provided "AS IS" without warranty of any kind (expressed or implied). Apex Microtechnology reserves the right to make changes without further notice to any specifications or products mentioned herein to improve reliability. This document is the property of Apex Microtechnology and by furnishing this information, Apex Microtechnology grants no license, expressed or implied under any patents, mask work rights, copyrights, trademarks, trade secrets or other intellectual property rights. Apex Microtechnology owns the copyrights associated with the information contained herein and gives consent for copies to be made of the information only for use within your organization with respect to Apex Microtechnology integrated circuits or other products of Apex Microtechnology. This consent does not extend to other copying such as copying for general distribution, advertising or promotional purposes, or for creating any work for resale.

APEX MICROTECHNOLOGY PRODUCTS ARE NOT DESIGNED, AUTHORIZED OR WARRANTED TO BE SUITABLE FOR USE IN PRODUCTS USED FOR LIFE SUPPORT, AUTOMOTIVE SAFETY, SECURITY DEVICES, OR OTHER CRITICAL APPLICATIONS. PRODUCTS IN SUCH APPLICATIONS ARE UNDERSTOOD TO BE FULLY AT THE CUSTOMER OR THE CUSTOMER'S RISK.

Apex Microtechnology, Apex and Apex Precision Power are trademarks of Apex Microtechnology, Inc. All other corporate names noted herein may be trademarks of their respective holders.

## X-ON Electronics

Largest Supplier of Electrical and Electronic Components

*Click to view similar products for [Amplifier IC Development Tools](#) category:*

*Click to view products by [Apex Microtechnology](#) manufacturer:*

Other Similar products are found below :

[MIOP 42109](#) [MADL-011014-001SMB](#) [AD8137YCP-EBZ](#) [MCP6XXXEV-AMP3](#) [MCP6XXXEV-AMP4](#) [TS1001DB](#) [TS1005DB-SOT](#)  
[VCA8500BOARD](#) [DEM-OPA-MSOP-2B](#) [DEM-OPA-SO-3A](#) [DEM-OPA-SSOP-3D](#) [XB1014-QT-EV1](#) [XR1009ISO8EVB](#) [XR1009IST5EVB](#)  
[XR2008ISO8EVB](#) [LMH6882EVALNOPB](#) [OPA1S2384EVM](#) [THS4551RGTEVM](#) [TS1002DB](#) [TS1003DB](#) [TS1003DB-SOT](#) [TS1005DB](#)  
[UPC3237TK-EVAL-A](#) [ISL28218SOICEVAL1Z](#) [ISL28210SOICEVAL1Z](#) [ISL28127SOICEVAL1Z](#) [ISL28006FH-ADJEVAL1Z](#)  
[ISL28006FH-100EVAL1Z](#) [ADL5321-EVALZ](#) [ADM00443](#) [IS31AP4991-SLS2-EB](#) [CEB002](#) [AMC1200EVM](#) [STEVAL-CCA057V5](#)  
[STEVAL-CCA057V4](#) [EVAL-AD5750EBZ](#) [ADM00375](#) [ADL5246-EVALZ](#) [AD8417RM-EVALZ](#) [AD8417R-EVALZ](#) [AD8368-EVALZ](#)  
[AD8260-EVALZ](#) [DEM-OPA-SOT-1A](#) [DEM-OPA-SO-1C](#) [DC1057A](#) [OPA2836IDGSEVM](#) [THS7319EVM](#) [XR2009ISO8EVB](#)  
[XR2008IMP8EVB](#) [XR1008IST5EVB](#)