

High Voltage Power Operational Amplifier



FEATURES

- ◆ RoHS COMPLIANT
- ◆ MONOLITHIC MOS TECHNOLOGY
- ◆ LOW COST
- ◆ HIGH VOLTAGE OPERATION – 350V
- ◆ LOW QUIESCENT CURRENT TYP. – 2.2mA
- ◆ NO SECOND BREAKDOWN
- ◆ HIGH OUTPUT CURRENT – 120 mA PEAK

APPLICATIONS

- ◆ TELEPHONE RING GENERATOR
- ◆ PIEZO ELECTRIC POSITIONING
- ◆ ELECTROSTATIC TRANSDUCER & DEFLECTION
- ◆ DEFORMABLE MIRROR FOCUSING
- ◆ PACKAGING OPTIONS
- 7-pin DDPACK Surface Mount Package (PA340CC)

DESCRIPTION

The PA340 is a high voltage monolithic MOSFET operational amplifier achieving performance features previously found only in hybrid designs while increasing reliability. Inputs are protected from excessive common mode and differential mode voltages. The safe operating area (SOA) has no second breakdown limitations. External compensation provides the user flexibility in choosing optimum gain and bandwidth for the application.

The surface mount package of the PA340CC is an industry standard non-hermetic plastic 7-pin DDPACK.

FIGURE 1: Equivalent Schematic

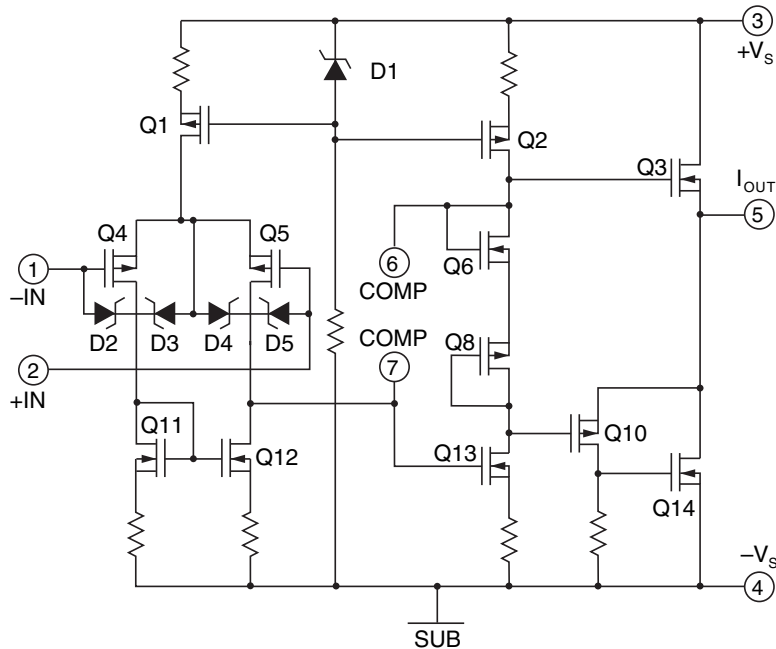

High voltage considerations should be taken when designing board layouts for the PA340. The PA340 may require a derate in supply voltage depending on the spacing used for board layout. The 14-mil minimum spacing of the 7-pin DDPACK is adequate to standoff the 350V rating of the PA340. However, a supply voltage derate to 250V is required if the spacing of circuit board artwork is less than 11 mils.

The metal tab of the PA340CC package is directly tied to -Vs.

TYPICAL APPLICATION



For C_c values, see graph on page 4.
 Note: C_c must be rated for full supply voltage.

FIGURE 2. External Connections.

Ref: APPLICATION NOTE 20: "Bridge Mode Operation of Power Amplifiers"

Two PA340 amplifiers operated as a bridge driver for a piezo transducer provides a low cost 660 volt total drive capability. The $R_N C_N$ network serves to raise the apparent gain of A2 at high frequencies. If R_N is set equal to R the amplifiers can be compensated identically and will have matching bandwidths.

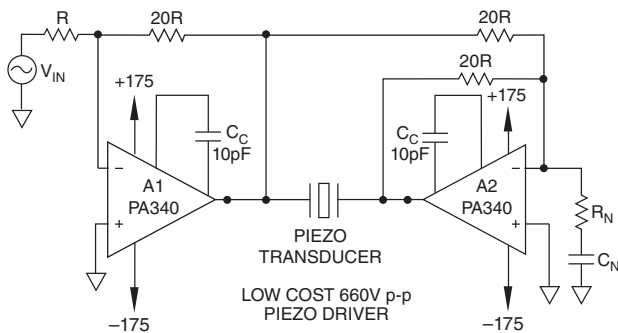

FIGURE 3. Low Cost 660V_{p-p} Piezo Driver

1. CHARACTERISTICS AND SPECIFICATIONS

ABSOLUTE MAXIMUM RATINGS

Parameter	Symbol	Min	Max	Units
SUPPLY VOLTAGE, $+V_s$ to $-V_s$			350	V
OUTPUT CURRENT, continuous within SOA			60	mA
OUTPUT CURRENT, peak (Note 3)			120	mA
POWER DISSIPATION, continuous @ $T_c = 25^\circ\text{C}$			14	W
INPUT VOLTAGE, differential		-16	+16	V
INPUT VOLTAGE, common mode		$-V_s$	$+V_s$	V
TEMPERATURE, pin solder - 10 sec			220	$^\circ\text{C}$
TEMPERATURE, junction (Note 2)			150	$^\circ\text{C}$
TEMPERATURE, storage		-65	150	$^\circ\text{C}$
TEMPERATURE RANGE, powered (case)		-40	125	$^\circ\text{C}$

SPECIFICATIONS (PER AMPLIFIER)

Parameter	Test Conditions (Note 1)	Min	Typ	Max	Units
INPUT					
OFFSET VOLTAGE, initial			12	40	mV
OFFSET VOLTAGE, vs. temperature (Note 3)	25°C to 85°C		17	250	$\mu\text{V}/^\circ\text{C}$
OFFSET VOLTAGE, vs. temperature (Note 3)	-25°C to 25°C		18	500	$\mu\text{V}/^\circ\text{C}$
OFFSET VOLTAGE, vs. supply			4.5		$\mu\text{V}/\text{V}$
OFFSET VOLTAGE, vs. time			80		$\mu\text{V}/\text{kh}$
BIAS CURRENT, initial			50	200	pA
BIAS CURRENT, vs. supply			2		pA/V
OFFSET CURRENT, initial			50	200	pA
INPUT IMPEDANCE, DC			10^{11}		Ω
INPUT CAPACITANCE			3		pF
COMMON MODE, voltage range		$+V_s - 12$			V
COMMON MODE, voltage range		$-V_s + 12$			V
COMMON MODE REJECTION, DC	$V_{CM} = \pm 90\text{VDC}$	84	115		dB
NOISE, broad band	10kHz BW, $R_s = 1\text{K}\Omega$		337		$\mu\text{V RMS}$
GAIN					
OPEN LOOP at 15Hz	$R_L = 5\text{K}\Omega$	90	103		dB
GAIN BANDWIDTH PRODUCT	@1MHz		10		MHz
POWER BANDWIDTH	280V p-p		35		kHz

Parameter	Test Conditions (Note 1)	Min	Typ	Max	Units
OUTPUT					
VOLTAGE SWING	$I_o = 40\text{mA}$	$\pm V_s \mp 12$	$\pm V_s \mp 10$		V
CURRENT, peak (Note 3)		120			mA
CURRENT, continuous		60			mA
SETTLING TIME to 0.1%	10V step, $A_v = -10$		2		μs
SLEW RATE	$C_c = 4.7\text{pF}$		32		V/ μS
RESISTANCE, 10mA (Note 4)	$R_{CL} = 0\Omega$		91		Ω
RESISTANCE, 40mA (Note 4)	$R_{CL} = 0\Omega$		65		Ω
POWER SUPPLY					
VOLTAGE		± 10	± 150	± 175	V
CURRENT, quiescent			2.2	2.5	mA
THERMAL					
RESISTANCE, AC junction to case	$F > 60\text{Hz}$		5.9	6.85	$^{\circ}\text{C/W}$
RESISTANCE, DC junction to case	$F < 60\text{Hz}$		7.7	8.9	$^{\circ}\text{C/W}$
RESISTANCE, junction to air (Note 5)	Full temperature range		27		$^{\circ}\text{C/W}$
TEMPERATURE RANGE, case	Meets full range specifications	-25	25	+85	$^{\circ}\text{C}$

NOTES:

1. Unless otherwise noted $T_c = 25^{\circ}\text{C}$, $C_c = 6.8\text{pF}$. DC input specifications are \pm value given. Power supply voltage is typical rating.
2. Long term operation at the maximum junction temperature will result in reduced product life. Derate internal power dissipation to achieve high MTTF. For guidance, refer to heatsink data sheet.
3. Guaranteed but not tested.
4. Since the PA340 has no current limit, load impedance must be large enough to limit output current to 120mA.
5. Heat tab attached to 3/32" FR-4 board with 2oz. copper. Topside copper area (heat tab directly attached) = 1000 sq. mm, backside copper area = 2500 sq. mm, board area = 2500 sq. mm.

CAUTION The PA340 is constructed from MOSFET transistors. ESD handling procedures must be observed.

2. TYPICAL PERFORMANCE GRAPHS

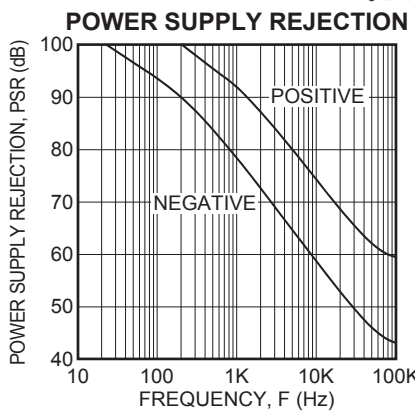
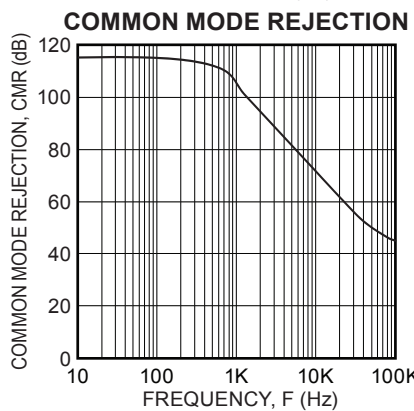
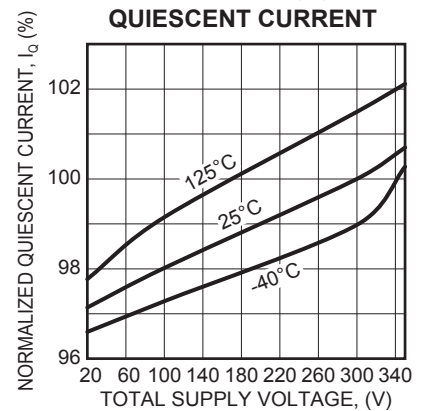
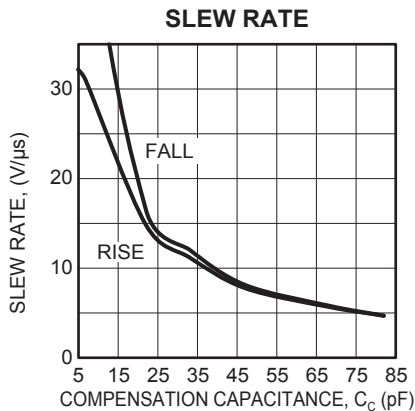
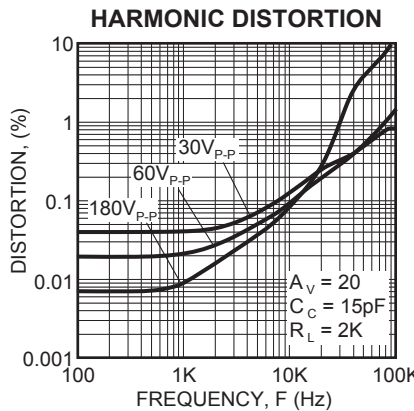
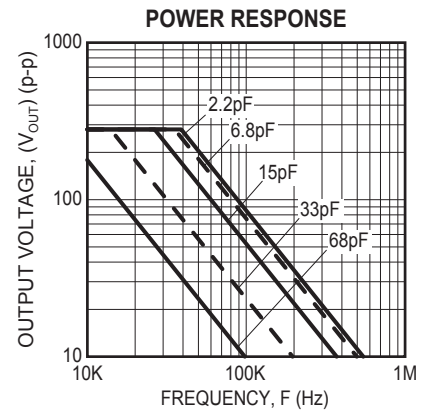
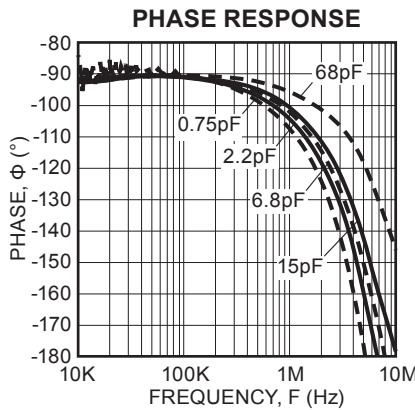
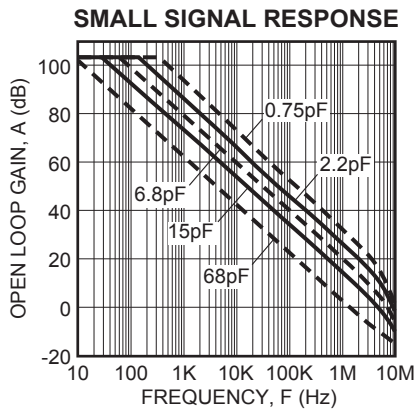
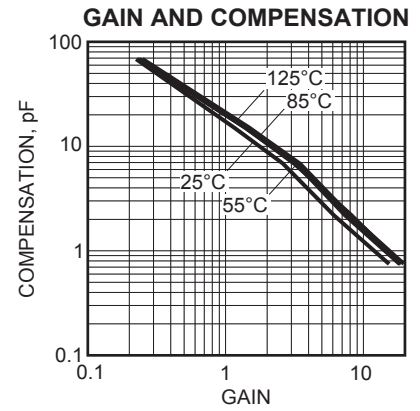
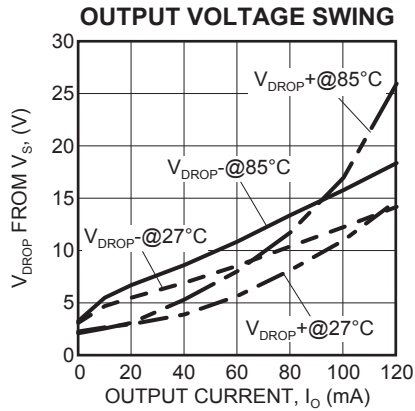
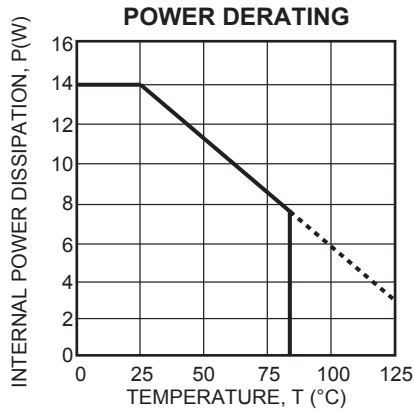

3. APPLICATION INFORMATION

Please read Application Note 1 "General Operating Considerations" which covers stability, power supplies, heat sinking, mounting, current limit, SOA interpretation, and specification interpretation. Visit www.apexanalog.com for design tools that help automate tasks such as calculations for stability, internal power dissipation, current limit, heat sink selection, Apex Microtechnology's complete Application Notes library, Technical Seminar Workbook and Evaluation Kits.

3.1 PHASE COMPENSATION

Open loop gain and phase shift both increase with increasing temperature. The PHASE COMPENSATION typical graph shows closed loop gain and phase compensation capacitor value relationships for four case temperatures. The curves are based on achieving a phase margin of 50°. Calculate the highest case temperature for the application (maximum ambient temperature and highest internal power dissipation) before choosing the compensation. Keep in mind that when working with small values of compensation, parasitics may play a large role in performance of the finished circuit. The compensation capacitor must be rated for at least the total voltage applied to the amplifier and should be a temperature stable type such as NPO or COG.

3.2 OTHER STABILITY CONCERNS

There are two important concepts about closed loop gain when choosing compensation. They stem from the fact that while "gain" is the most commonly used term, β (the feedback factor) is really what counts when designing for stability.

1. Gain must be calculated as a non-inverting circuit (equal input and feedback resistors can provide a signal gain of -1, but for calculating offset errors, noise, and stability, this is a gain of 2).
2. Including a feedback capacitor changes the feedback factor or gain of the circuit. Consider $R_{IN} = 4.7k$, $R_f = 47k$ for a gain of 11. Compensation of 4.7 to 6.8pF would be reasonable. Adding 33pF parallel to the 47K rolls off the circuit at 103kHz, and at 2MHz has reduced gain from 11 to roughly 1.5 and the circuit is likely to oscillate.

As a general rule the DC summing junction impedance (parallel combination of the feedback resistor and all input resistors) should be limited to 5K ohms or less. The amplifier input capacitance of about 6pF, plus capacitance of connecting traces or wires and (if used) a socket will cause undesirable circuit performance and even oscillation if these resistances are too high. In circuits requiring high resistances, measure or estimate the total sum point capacitance, multiply by R_{IN}/R_f and parallel R_f with this value. Capacitors included for this purpose are usually in the single digit pF range. This technique results in equal feedback factor calculations for AC and DC cases. It does not produce a roll off, but merely keeps β constant over a wide frequency range. Paragraph 6 of Application Note 19 details suitable stability tests for the finished circuit.

3.3 SAFE OPERATING AREA

The MOSFET output stage of the PA340 is not limited by second breakdown considerations as in bipolar output stages. However there are still three distinct limitations:

1. Voltage withstand capability of the transistors.
2. Current handling capability of the die metallization.
3. Temperature of the output MOSFETS.

These limitations can be seen in the SOA (see Safe Operating Area graphs). Note that each pulse capability line shows a constant power level (unlike second breakdown limitations where power varies with voltage stress). These lines are shown for a case temperature of 25°C. Pulse stress levels for other case temperatures can be calculated in the same manner as DC power levels at different temperatures. The output stage is protected against transient flyback by the parasitic diodes of the output stage MOSFET structure. However, for protection against sustained high energy flyback external fast-recovery diodes must be used.

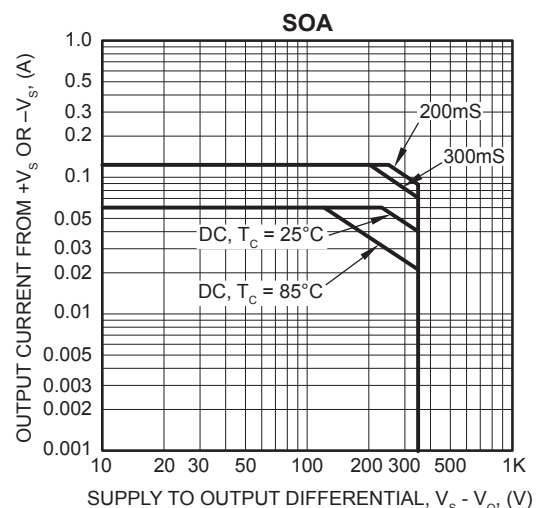

FIGURE 4. Safe Operating Area

3.4 HEATSINKING

The PA340CC 7-pin DDPACK surface mountable package has a large exposed integrated copper heatslug to which the monolithic amplifier is directly attached. The PA340CC requires surface mount techniques of heatsinking. A solder connection to a copper foil area as defined in Note 5 of Page 3 is recommended for circuit board layouts. This may be adequate heatsinking but the large number of variables suggests temperature measurements to be made on the top of the package. Do not allow the temperature to exceed 85°C.

3.5 OVERVOLTAGE PROTECTION

Although the PA340 can withstand differential input voltages up to 16V, in some applications additional external protection may be needed. Differential inputs exceeding 16V will be clipped by the protection circuitry. However, if more than a few milliamps of current is available from the overload source, the protection circuitry could be destroyed. For differential sources above 16V, adding series resistance limiting input current to 1mA will prevent damage. Alternatively, 1N4148 signal diodes connected anti-parallel across the input pins is usually sufficient. In more demanding applications where bias current is important, diode connected JFETs such as 2N4416 will be required. See Q1 and Q2 in Figure 5. In either case the differential input voltage will be clamped to 0.7V. This is sufficient overdrive to produce the maximum power bandwidth.

In the case of inverting circuits where the +IN pin is grounded, the diodes mentioned above will also afford protection from excessive common mode voltage. In the case of non-inverting circuits, clamp diodes from each input to each supply will provide protection. Note that these diodes will have substantial reverse bias voltage under normal operation and diode leakage will produce errors.

Some applications will also need over-voltage protection devices connected to the power supply rails. Unidirectional zener diode transient suppressors are recommended. The zeners clamp transients to voltages within the power supply rating and also clamp power supply reversals to ground. Whether the zeners are used or not the system power supply should be evaluated for transient performance including power-on overshoot and power-off polarity reversals as well as line regulation. See Z1 and Z2 in Figure 5.

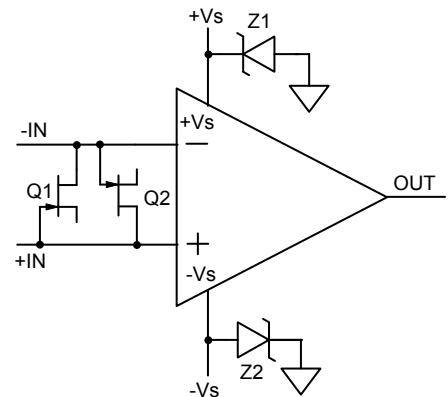

FIGURE 5. Overvoltage Protection

NEED TECHNICAL HELP? CONTACT APEX SUPPORT!

For all Apex Microtechnology product questions and inquiries, call toll free 800-546-2739 in North America.

For inquiries via email, please contact apex.support@apexanalog.com.

International customers can also request support by contacting their local Apex Microtechnology Sales Representative.

To find the one nearest to you, go to www.apexanalog.com

IMPORTANT NOTICE

Apex Microtechnology, Inc. has made every effort to insure the accuracy of the content contained in this document. However, the information is subject to change without notice and is provided "AS IS" without warranty of any kind (expressed or implied). Apex Microtechnology reserves the right to make changes without further notice to any specifications or products mentioned herein to improve reliability. This document is the property of Apex Microtechnology and by furnishing this information, Apex Microtechnology grants no license, expressed or implied under any patents, mask work rights, copyrights, trademarks, trade secrets or other intellectual property rights. Apex Microtechnology owns the copyrights associated with the information contained herein and gives consent for copies to be made of the information only for use within your organization with respect to Apex Microtechnology integrated circuits or other products of Apex Microtechnology. This consent does not extend to other copying such as copying for general distribution, advertising or promotional purposes, or for creating any work for resale.

APEX MICROTECHNOLOGY PRODUCTS ARE NOT DESIGNED, AUTHORIZED OR WARRANTED TO BE SUITABLE FOR USE IN PRODUCTS USED FOR LIFE SUPPORT, AUTOMOTIVE SAFETY, SECURITY DEVICES, OR OTHER CRITICAL APPLICATIONS. PRODUCTS IN SUCH APPLICATIONS ARE UNDERSTOOD TO BE FULLY AT THE CUSTOMER OR THE CUSTOMER'S RISK.

Apex Microtechnology, Apex and Apex Precision Power are trademarks of Apex Microtechnology, Inc. All other corporate names noted herein may be trademarks of their respective holders.

X-ON Electronics

Largest Supplier of Electrical and Electronic Components

Click to view similar products for [Operational Amplifiers - Op Amps](#) category:

Click to view products by [Apex Microtechnology](#) manufacturer:

Other Similar products are found below :

[LM258AYDT](#) [LM358SNG](#) [430227FB](#) [UPC824G2-A](#) [LT1678IS8](#) [042225DB](#) [058184EB](#) [UPC259G2-A](#) [NTE925](#) [AZV358MTR-G1](#)
[AP4310AUMTR-AG1](#) [HA1630D02MMEL-E](#) [HA1630S01LPEL-E](#) [NJU77806F3-TE1](#) [NCV20034DR2G](#) [LM324EDR2G](#) [LM2902EDR2G](#)
[NTE778S](#) [NTE871](#) [NTE924](#) [NTE937](#) [MCP6V17T-E/MNY](#) [MCP6V19-E/ST](#) [MCP6V36UT-E/LTY](#) [MXD8011HF](#) [SCY6358ADR2G](#)
[LTC2065HUD#PBF](#) [NJM2904CRB1-TE1](#) [2SD965T-R](#) [RS6332P XK](#) [BDM8551](#) [BDM321](#) [MD1324](#) [COS8052SR](#) [COS8552SR](#) [COS8554SR](#)
[COS2353SR](#) [COS724TR](#) [ASOPD4580S-R](#) [RS321BKXF](#) [ADA4097-1HUIZ-RL7](#) [NCV4333DTBR2G](#) [EL5420CRZ-T7A](#) [AS324MTR-E1](#)
[AS358MMTR-G1](#) [MCP6472T-E/MS](#) [MCP6491T-ELTY](#) [MCP662-E/MF](#) [TLC073IDGQR](#) [TLC081AIP](#)