

Power Operational Amplifier

FEATURES

- High Voltage - 300V
- High Output Current – 1.5A
- 70 Watt Dissipation Capability
- 175 MHz Gain Bandwidth
- 250 V/ μ s Slew Rate



APPLICATIONS

- PZT Drive
- Magnetic Deflection
- Programmable Power Supplies
- 70V Line Audio to 70W

DESCRIPTION

The PA96 is a state of the art high voltage, high current operational amplifier designed to drive resistive, capacitive and inductive loads. For optimum linearity, the output stage is biased for class A/B operation. External compensation provides user flexibility in maximizing bandwidth at any gain setting. The safe operating area (SOA) can be observed for all operating conditions by selection of user programmable current limit. For continuous operation under load, a heatsink of proper rating is required.

The hybrid integrated circuit utilizes thick film (cermet) resistors, ceramic capacitors and semiconductor chips to maximize reliability, minimize size and give top performance. Ultrasonically bonded aluminum wires provide reliable interconnections at all operating temperatures. The 8-pin TO-3 package is hermetically sealed and electrically isolated. The use of compressible isolation washers voids the warranty.

TYPICAL CONNECTION

Figure 1: Typical Connection

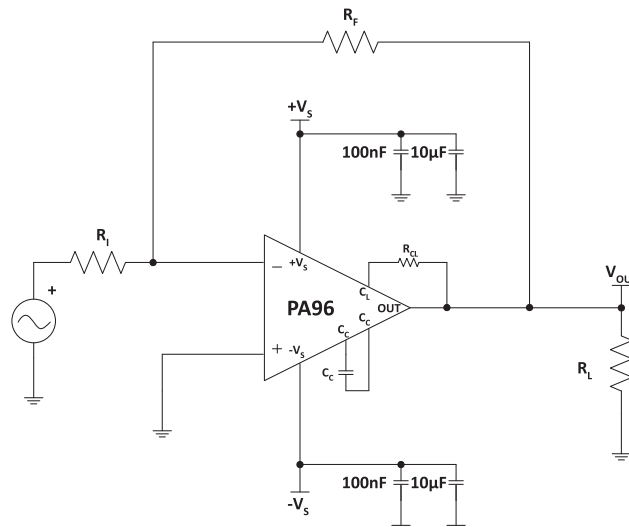

PINOUT AND DESCRIPTION TABLE

Figure 2: External Connections

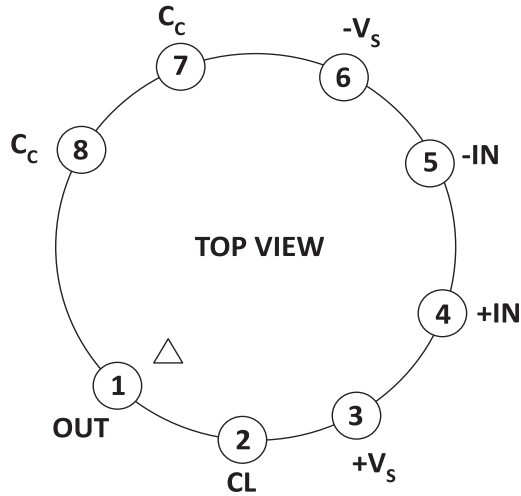

Pin Number	Name	Description
1	OUT	The output. Connect this pin to load and to the feedback resistors.
2	CL	Connect to the current limit resistor, and then the OUT pin. Output current flows into/out of this pin through R_{CL} .
3	+Vs	The positive supply rail.
4	+IN	The non-inverting input.
5	-IN	The inverting input.
6	-Vs	The negative supply rail.
7, 8	CC	Compensation capacitor connection. Select value based on Phase Compensation. See applicable section.

SPECIFICATIONS

The power supply voltage specified under typical (TYP) applies unless noted as a test condition.

ABSOLUTE MAXIMUM RATINGS

Parameter	Symbol	Min	Max	Units
Supply Voltage, total	$+V_S$ to $-V_S$		300	V
Output Current, source, continuous	I_O		1.5	A
Power Dissipation, internal, DC	P_D		70	W
Input Voltage, differential	V_{IN} (Diff)		± 15	V
Input Voltage, common mode	V_{cm}	$-V_S$	$+V_S$	V
Temperature, pin solder, 10s max.			350	$^{\circ}\text{C}$
Temperature, junction ¹	T_J		150	$^{\circ}\text{C}$
Temperature Range, storage		-65	150	$^{\circ}\text{C}$
Operating Temperature Range, case	T_C	-55	125	$^{\circ}\text{C}$

1. Long term operation at the maximum junction temperature will result in reduced product life. Derate power dissipation to achieve high MTTF.

CAUTION

The internal substrate contains beryllia (BeO). Do not break the seal. If accidentally broken, do not crush, machine, or subject to temperatures in excess of 850 $^{\circ}\text{C}$ to avoid generating toxic fumes.

INPUT

Parameter	Test Conditions	Min	Typ	Max	Units
Offset Voltage			1	5	mV
Offset Voltage vs. temperature	Full temp range		20	50	$\mu\text{V}/^{\circ}\text{C}$
Offset Voltage vs. supply				20	$\mu\text{V}/\text{V}$
Bias Current, initial				200	μA
Bias Current vs. Supply				0.1	$\mu\text{A}/\text{V}$
Offset Current, initial				50	μA
Input Resistance, DC			10^{11}		Ω
Input Capacitance			4		pF
Common Mode Voltage Range ¹		$\pm V_S - 13$			V
Common Mode Rejection, DC		92			dB
Noise	100 kHz bandwidth, 1 k Ω R_S		6		$\mu\text{V RMS}$

1. $+V_S$ and $-V_S$ denote the positive and negative supply rail respectively. Total V_S is measured from $+V_S$ to $-V_S$.

GAIN

Parameter	Test Conditions	Min	Typ	Max	Units
Open Loop @ 15 Hz	$R_L = 1\text{ k}\Omega$, $C_C = 100\text{ pF}$	96	114		dB
Gain Bandwidth Product @ 1 MHz	$V_S = 150\text{ V}$, $-V_S = 150\text{ V}$, $A = -100$, $R_F = 100\text{ k}\Omega$	100	175		MHz
Phase Margin	Full temp range, using recommended C_C for gain.	60			°
PBW	250V p-p output, 100 Ω , +150V Supplies, $C_c = 0\text{ pF}$		100		kHz

OUTPUT

Parameter	Test Conditions	Min	Typ	Max	Units
Voltage Swing ¹	$I_O = 1.5\text{ A}$	$+V_S - 12$	$+V_S - 5.6$		V
Voltage Swing ¹	$I_O = -1.5\text{ A}$	$-V_S + 12$	$-V_S + 10$		V
Voltage Swing ¹	$I_O = 0.1\text{ A}$	$+V_S - 8$			V
Voltage Swing ¹	$I_O = -0.1\text{ A}$	$-V_S + 8$			V
Current, continuous, DC		1.5			A
Slew Rate	$A_V = -100$, $\pm 150\text{ V}$ Supplies, 250 Ω load negative slope, Positive slope much faster	200	250		V/ μs
Settling Time, to 0.1%	$A_V = -100$, 1V Step, $C_C = 0\text{ pF}$		2		μs
Resistance, open loop	DC, 1A Load		7	10	Ω

1. $+V_S$ and $-V_S$ denote the positive and negative supply rail respectively. Total V_S is measured from $+V_S$ to $-V_S$.

POWER SUPPLY

Parameter	Test Conditions	Min	Typ	Max	Units
Voltage		± 15	± 100	± 150	V
Current, Quiescent total		25	30	35	mA
Current, Quiescent output stage only			10		mA

THERMAL

Parameter	Test Conditions	Min	Typ	Max	Units
Resistance, AC Junction to Case ¹	Full temp range, $f > 60$ Hz		1.2	1.3	°C/W
Resistance, DC Junction to Case	Full temp range, $f < 60$ Hz		1.6	1.8	°C/W
Resistance, Junction to Ambient			30		°C/W
Temperature Range, case	Meets full range specs	-25		85	°C

1. Rating applies if the output current alternates between both output transistors at a rate faster than 60 Hz.

TYPICAL PERFORMANCE GRAPHS

Figure 3: Open Loop Frequency Response

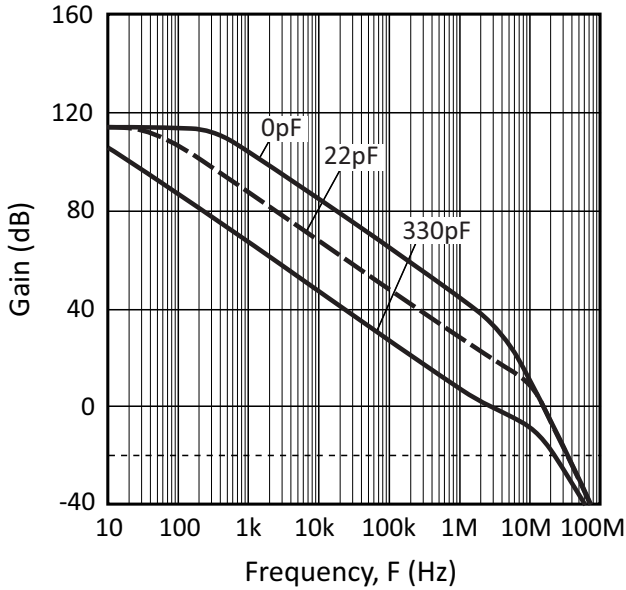

Figure 4: Open Loop Phase Response

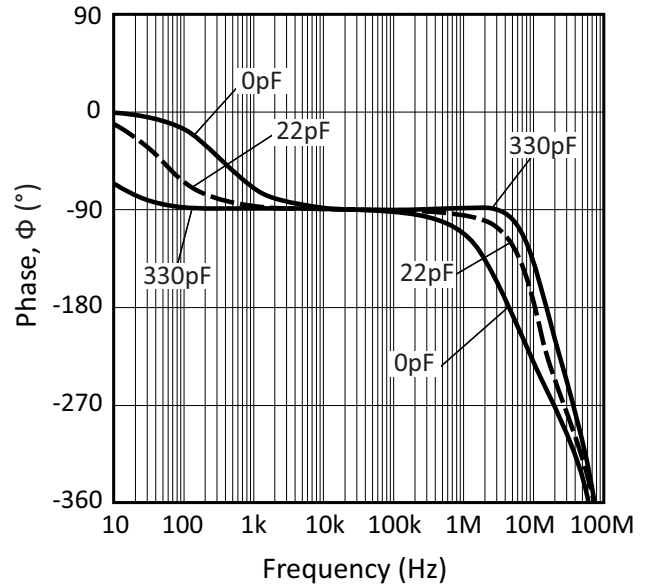

Figure 5: Gain Bandwidth vs. +Supply Voltage

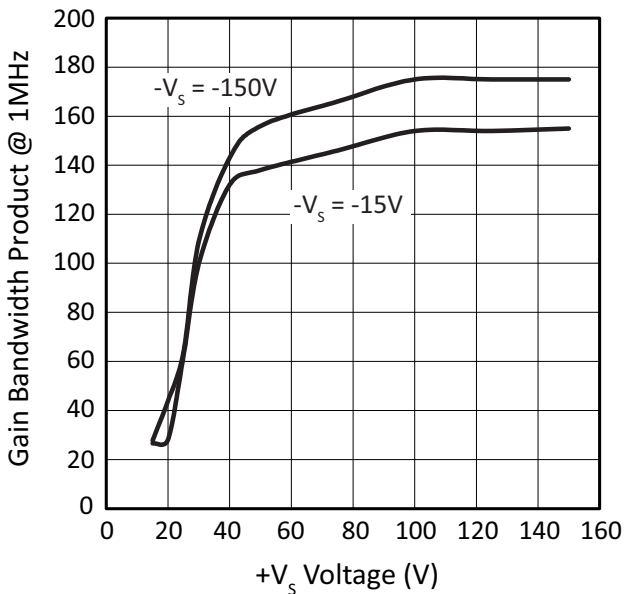

Figure 6: Rail to Rail Pulse Response

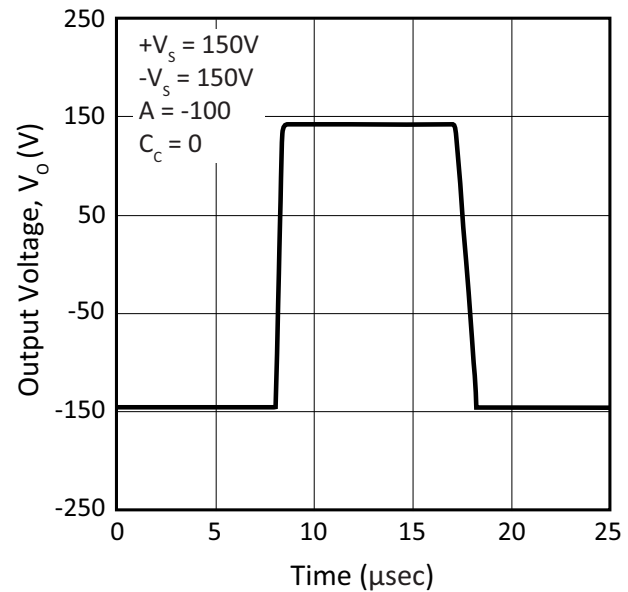

Figure 7: Small Signal Pulse Response

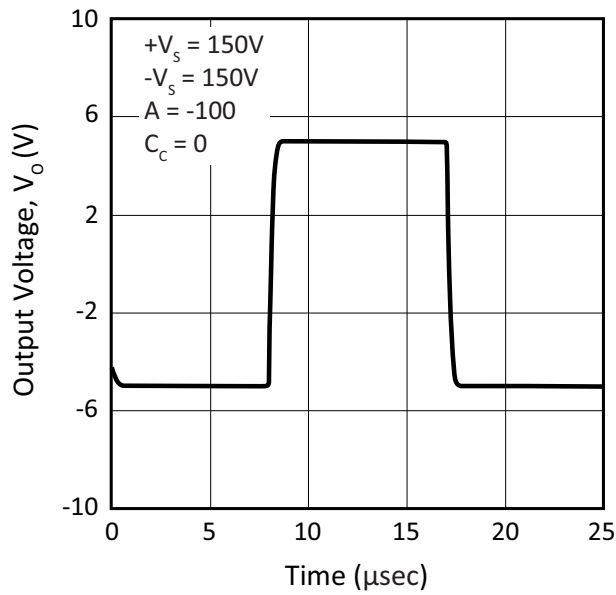

Figure 8: Large Signal Pulse Response

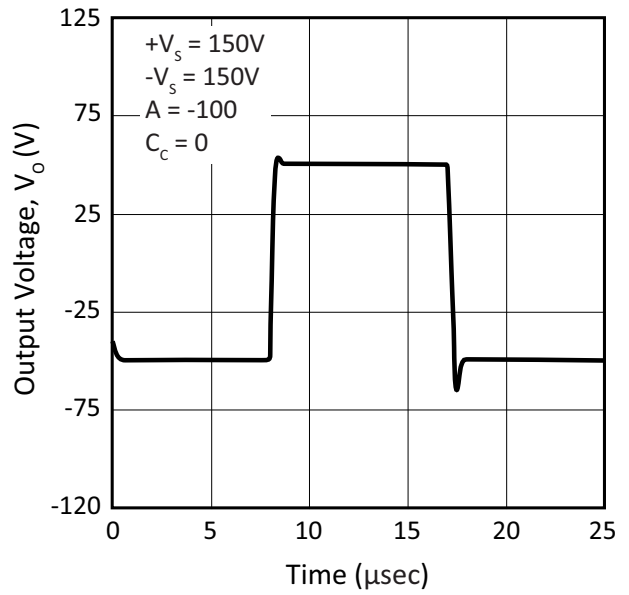

Figure 9: Output Voltage Swing

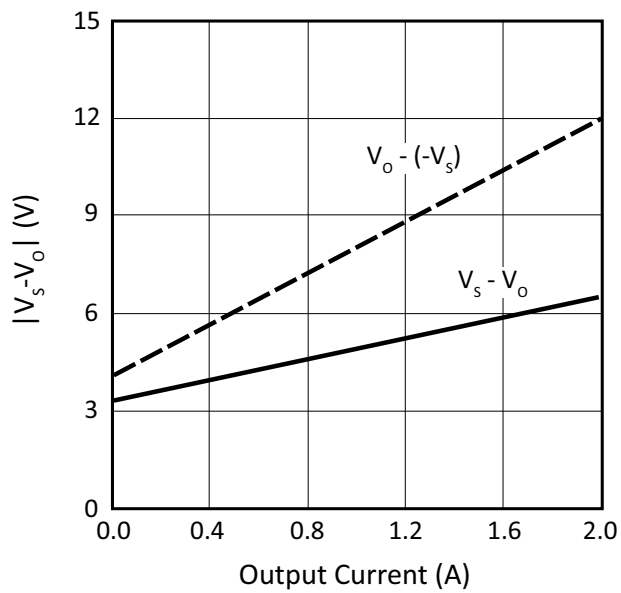

Figure 10: DC Offset vs. Power Supply

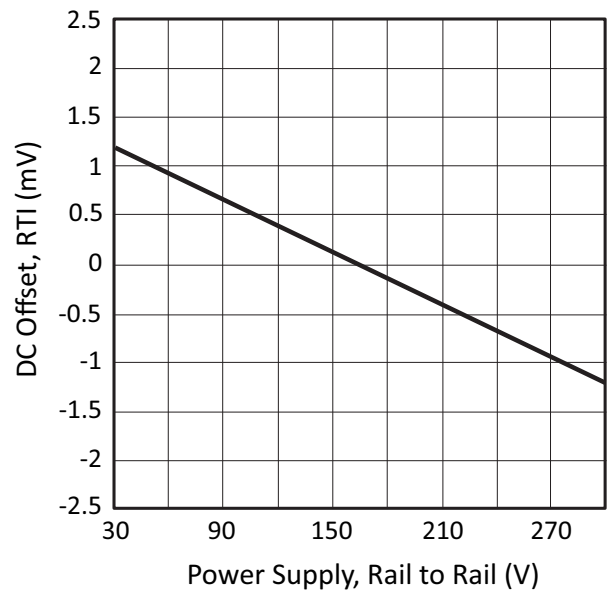

Figure 11: Quiescent Current vs. Temperature

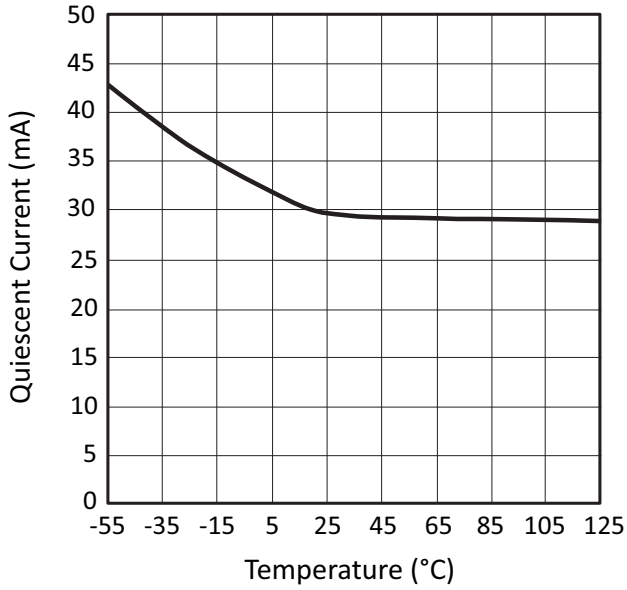

Figure 12: Quiescent Current vs. Power Supply

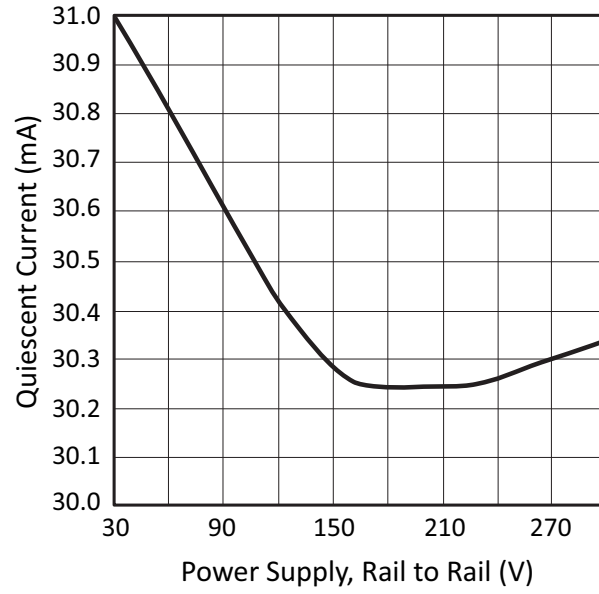
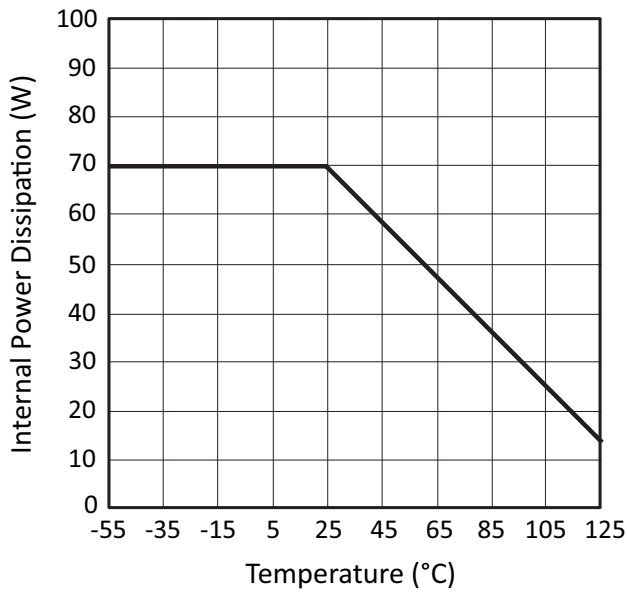
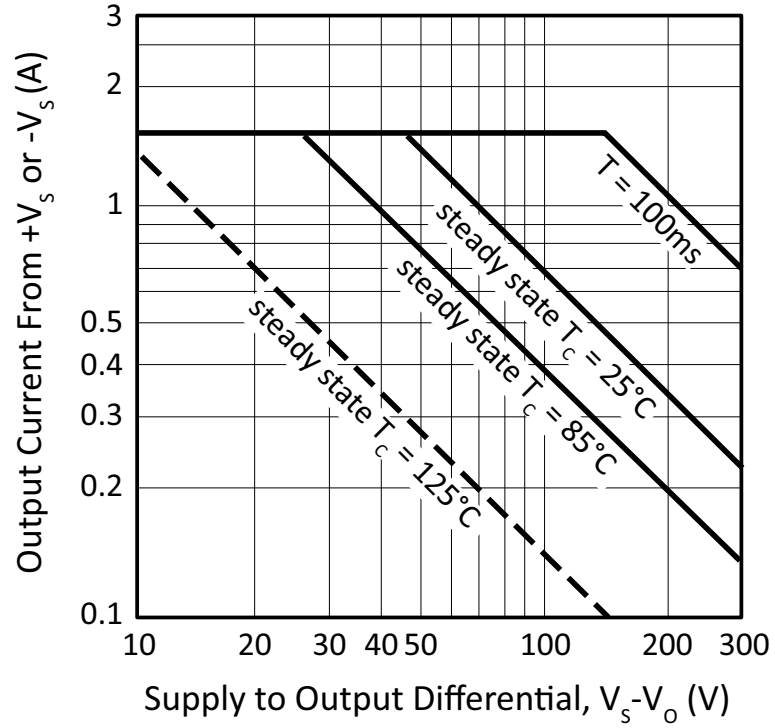

Figure 13: Power Derating



SAFE OPERATING AREA (SOA)

Figure 14: SOA



GENERAL

Please read Application Note 1 “General Operating Considerations” which covers stability, supplies, heat sinking, mounting, current limit, SOA interpretation, and specification interpretation. Visit www.apexanalog.com for Apex Microtechnology’s complete Application Notes library, Technical Seminar Workbook, and Evaluation Kits.

TYPICAL APPLICATION

The MOSFET output stage of the PA96 provides superior SOA performance compared to bipolar output stages where secondary breakdown is a concern. The extended SOA is ideal in applications where the load is highly reactive and may impose simultaneously both high voltage and high current across the output stage transistors. In the figure above a piezo-electric transducer is driven to high currents and high voltages by the PA96.

Figure 15: Typical Application (PZT Position Control)

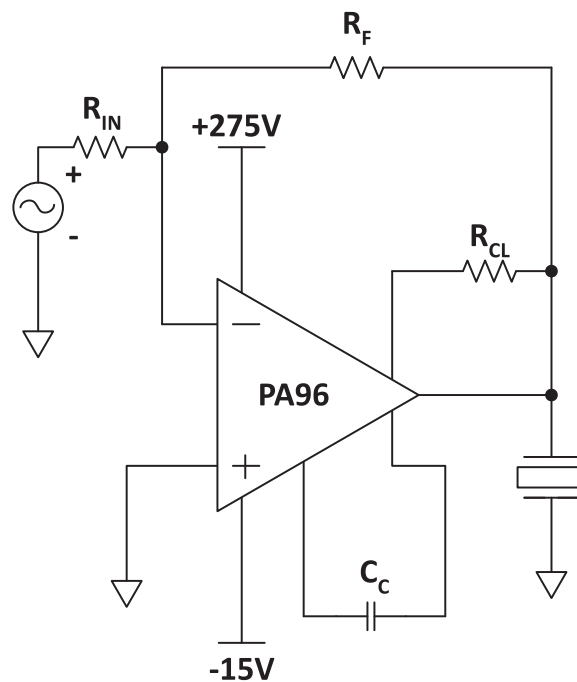

SPECIAL PRECAUTIONS

The PA96 operates with up 300V rail to rail voltage, and delivers up to 1.5A of current. Precautions should be taken for the safety of the user and the amplifier.

Although the non-operating common mode input range is rail to rail, the differential input voltage must not exceed ± 15 V.

Therefore; if the feedback ratio is less than 10, even if caused by disconnecting a signal source, typical power turn on transients can destroy the amplifier.

Similarly in a voltage follower application a large differential transient can be generated if the slew rate of the input is greater than that of the voltage follower.

Therefore it is prudent to clamp the input with series back to back diodes as shown below.

Figure 16:

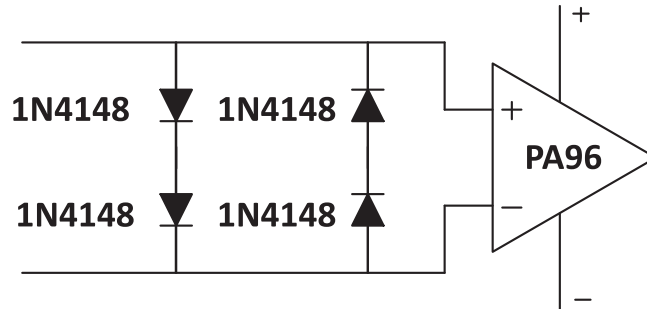

If experimentally optimizing the compensation capacitor, turn off the supplies and let them bleed to low voltage before installing each new value. Otherwise internal current pulses of up to 3 amps can be induced. Also, do you want your fingers around 300V?

Essentially the full rail to rail power supply voltage may be applied to the compensation capacitor. A 400V COG or Mica capacitor is recommended.

POWER BANDWIDTH

The power bandwidth is $1/(\pi \times \text{the negative edge slew time})$. The slew time is determined by the compensation capacitor, load, and internal device capacitance; it is independent of closed loop gain. The uncompensated power bandwidth is typically 100 kHz for a 250Vp-p output signal into 100 Ω . It typically increases to above 300 kHz with no load.

COMPENSATION TABLE

The following table tabulates recommended compensation capacitor values vs. gain. These values will typically result in less than 2% overshoot and a -3db small signal bandwidth of greater than 1 MHz, except under operating conditions where uncompensated gain bandwidth is too low to support a 1 MHz bandwidth. (See Gain Bandwidth vs. Plus Power Supply curves). Note that other factors such as capacitance in parallel with the feedback resistor may reduce circuit bandwidth from that determined from the gain bandwidth curve.

Cc	Inverting Gain	
	From	To
150pf	1	2
51pf	2	5
33pf	5	10
22pf	10	20
10pf	20	50
5pf	50	100
None	100	up

Cc	Non-Inverting Gain	
	From	To
330pf	1	2
150pf	2	3
51pf	3	6
33pf	6	10
22pf	10	20
10pf	20	50
5pf	50	100
None	100	up

CURRENT LIMIT

For proper operation the current limit resistor, R_{CL} , must be connected as shown in the external connections diagram. The minimum value is 0.2Ω , with a maximum practical value of 100Ω . For optimum reliability the resistor should be set as high as possible. The value is calculated as:

$$I_L(A) = \frac{0.68V}{R_{CL}(\Omega)}$$

Note that the 0.68V is reduced by 2mV every °C rise in temperature.

Also note that the current limit can be set such that the SOA is exceeded on a continuous basis. As an example if the current limit was set at 1.5A and the supply was at 150V, a short to ground would produce 225 watts internal dissipation, greatly exceeding the 83 watt steady state SOA rating. Under some conditions of load and compensation the amplifier may oscillate at a low level when current limit is active, even though the amplifier is stable otherwise. The current will be limited to the programmed value in this situation. To minimize such occurrences, use a non-reactive resistor to program current limit.

PACKAGE OPTIONS

PACKAGE STYLE CE

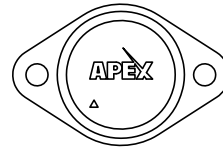
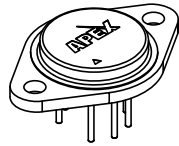

Ordinate dimensions for CAD layout

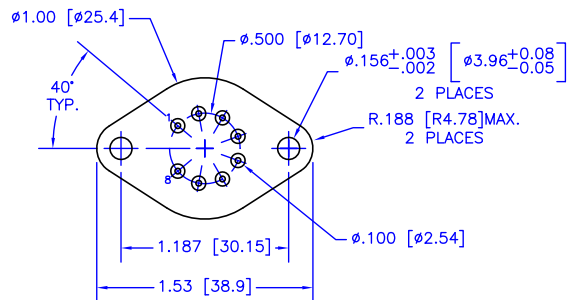
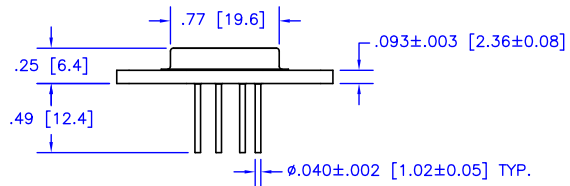
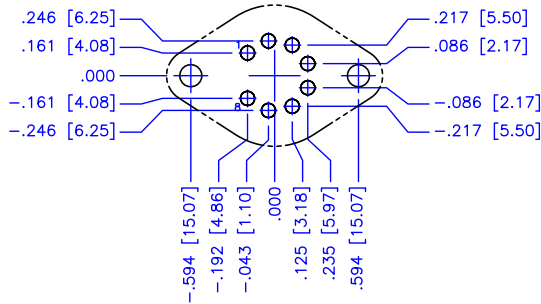

NOTES:

1. Dimensions are inches & [mm].
2. Triangle printed on lid denotes pin 1.
3. Header flatness within pin circle is .0005" TIR, max.
4. Header flatness between mounting holes is .0015" TIR, max.
5. Standard pin material: Solderable nickel-plated Alloy 52.
6. Header material: Nickel-plated cold-rolled steel.
7. Welded hermetic package seal
8. Isolation: 500 VDC any pin to case.
9. Package weight: .53 oz [15 g]

NEED TECHNICAL HELP? CONTACT APEX SUPPORT!

For all Apex Microtechnology product questions and inquiries, call toll free 800-546-2739 in North America. For inquiries via email, please contact apex.support@apexanalog.com. International customers can also request support by contacting their local Apex Microtechnology Sales Representative. To find the one nearest to you, go to www.apexanalog.com

IMPORTANT NOTICE

Apex Microtechnology, Inc. has made every effort to insure the accuracy of the content contained in this document. However, the information is subject to change without notice and is provided "AS IS" without warranty of any kind (expressed or implied). Apex Microtechnology reserves the right to make changes without further notice to any specifications or products mentioned herein to improve reliability. This document is the property of Apex Microtechnology and by furnishing this information, Apex Microtechnology grants no license, expressed or implied under any patents, mask work rights, copyrights, trademarks, trade secrets or other intellectual property rights. Apex Microtechnology owns the copyrights associated with the information contained herein and gives consent for copies to be made of the information only for use within your organization with respect to Apex Microtechnology integrated circuits or other products of Apex Microtechnology. This consent does not extend to other copying such as copying for general distribution, advertising or promotional purposes, or for creating any work for resale.

APEX MICROTECHNOLOGY PRODUCTS ARE NOT DESIGNED, AUTHORIZED OR WARRANTED TO BE SUITABLE FOR USE IN PRODUCTS USED FOR LIFE SUPPORT, AUTOMOTIVE SAFETY, SECURITY DEVICES, OR OTHER CRITICAL APPLICATIONS. PRODUCTS IN SUCH APPLICATIONS ARE UNDERSTOOD TO BE FULLY AT THE CUSTOMER OR THE CUSTOMER'S RISK.

Apex Microtechnology, Apex and Apex Precision Power are trademarks of Apex Microtechnology, Inc. All other corporate names noted herein may be trademarks of their respective holders.

X-ON Electronics

Largest Supplier of Electrical and Electronic Components

Click to view similar products for [Operational Amplifiers - Op Amps](#) category:

Click to view products by [Apex Microtechnology](#) manufacturer:

Other Similar products are found below :

[LM258AYDT](#) [LM358SNG](#) [430227FB](#) [UPC824G2-A](#) [LT1678IS8](#) [042225DB](#) [058184EB](#) [UPC259G2-A](#) [NTE925](#) [AZV358MTR-G1](#)
[AP4310AUMTR-AG1](#) [HA1630D02MMEL-E](#) [HA1630S01LPEL-E](#) [NJU77806F3-TE1](#) [NCV20034DR2G](#) [LM324EDR2G](#) [LM2902EDR2G](#)
[NTE778S](#) [NTE871](#) [NTE924](#) [NTE937](#) [MCP6V17T-E/MNY](#) [MCP6V19-E/ST](#) [MCP6V36UT-E/LTY](#) [MXD8011HF](#) [SCY6358ADR2G](#)
[LTC2065HUD#PBF](#) [NJM2904CRB1-TE1](#) [2SD965T-R](#) [RS6332P XK](#) [BDM8551](#) [BDM321](#) [MD1324](#) [COS8052SR](#) [COS8552SR](#) [COS8554SR](#)
[COS2353SR](#) [COS724TR](#) [ASOPD4580S-R](#) [RS321BKXF](#) [ADA4097-1HUIZ-RL7](#) [NCV4333DTBR2G](#) [EL5420CRZ-T7A](#) [AS324MTR-E1](#)
[AS358MMTR-G1](#) [MCP6472T-E/MS](#) [MCP6491T-ELTY](#) [MCP662-E/MF](#) [TLC073IDGQR](#) [TLC081AIP](#)