

Power Booster Amplifier

FEATURES

- Wide Supply Range — $\pm 30V$ to $\pm 100V$
- High Output Current — Up to 2A Continuous
- Voltage and Current Gain
- High Slew Rate — $50V/\mu s$ Minimum
- Programmable Output Current Limit
- High Power Bandwidth — 160 kHz Minimum
- Low Quiescent Current — 12mA Typical



APPLICATIONS

- High Voltage Instrumentation
- Electrostatic Transducers & Deflection
- Programmable Power Supplies up to $180V_{p-p}$

DESCRIPTION

The PB50 is a high voltage, high current amplifier designed to provide voltage and current gain for a small signal, general purpose op amp. Including the power booster within the feedback loop of the driver amplifier results in a composite amplifier with the accuracy of the driver and the extended output voltage range and current capability of the booster. The PB50 can also be used without a driver in some applications, requiring only an external current limit resistor to function properly.

The output stage utilizes complementary MOSFETs, providing symmetrical output impedance and eliminating secondary breakdown limitations imposed by Bipolar Junction Transistors. Internal feedback and gain-set resistors are provided for a pin-strappable gain of 3. Additional gain can be achieved with a single external resistor. Compensation is not required for most driver/gain configurations, but can be accomplished with a single external capacitor. Although the booster can be configured quite simply, enormous flexibility is provided through the choice of driver amplifier, current limit, supply voltage, voltage gain, and compensation.

This hybrid circuit utilizes a beryllia (BeO) substrate, thick film resistors, ceramic capacitors and semiconductor chips to maximize reliability, minimize size and give top performance. Ultrasonically bonded aluminum wires provide reliable interconnections at all operating temperatures. The 8-pin TO-3 package is electrically isolated and hermetically sealed using one-shot resistance welding. The use of compressible isolation washers voids the warranty.

TYPICAL CONNECTIONS

Figure 1: Typical Connections

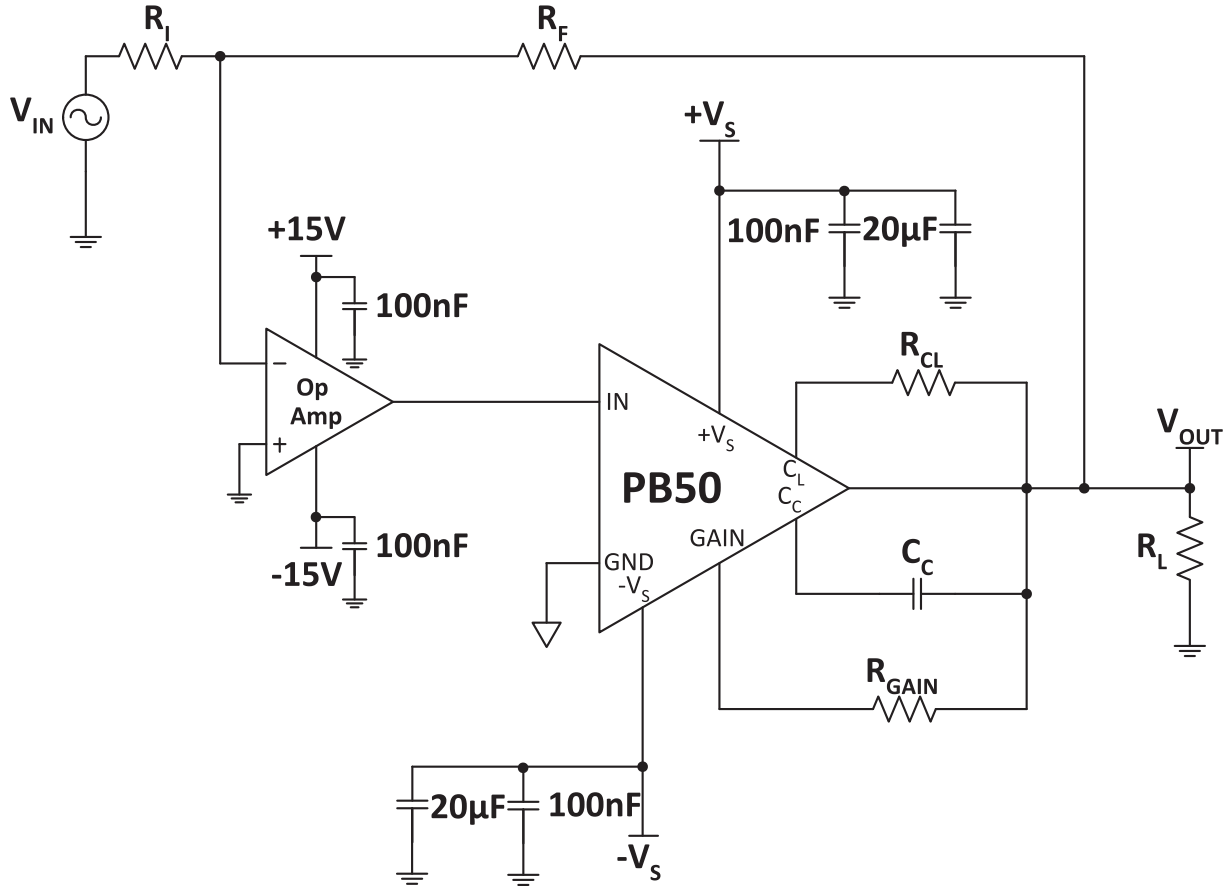

PINOUT AND DESCRIPTION TABLE

Figure 2: External Connections

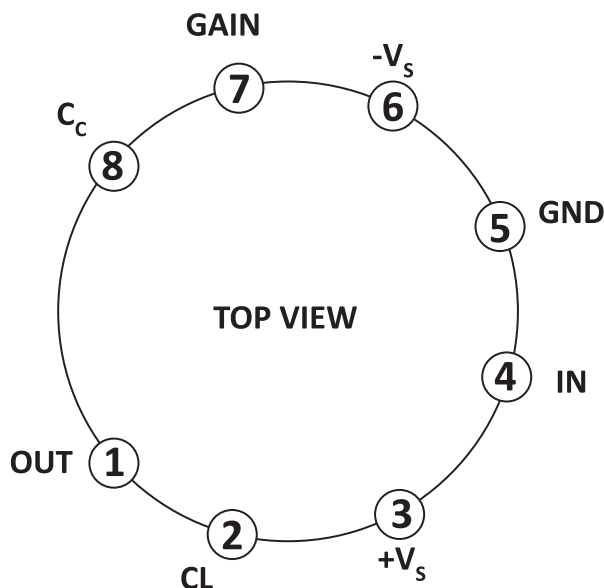

Pin Number	Name	Description
1	OUT	The output. Connect this pin to load and to the feedback resistors.
2	CL	Connect to the current limit resistor. Output current flows into/out of this pin through R_{CL} . The output pin and the load are connected to the other side of R_{CL} .
3	+Vs	The positive supply rail.
4	IN	The input.
5	GND	Ground. Connect to same ground as referenced by input amplifier.
6	-Vs	The negative supply rail.
7	GAIN	Gain resistor pin. Connect R_{GAIN} between GAIN and OUT. This will specify the gain for the power booster itself, not the composite amplifier. See applicable section.
8	CC	Compensation capacitor connection. Select value based on Phase Compensation. See applicable section.

SPECIFICATIONS

The power supply voltage specified under typical (TYP) applies, $T_C = 25^\circ\text{C}$ unless otherwise noted.

ABSOLUTE MAXIMUM RATINGS

Parameter	Symbol	Min	Max	Units
Supply Voltage, total	$+V_s$ to $-V_s$		200	V
Output Current, within SOA	I_O		2	A
Power Dissipation, internal @ $T_C = 25^\circ\text{C}$ ¹	P_D		35	W
Input Voltage, referred to common	V_{cm}	-15	+15	V
Temperature, pin solder, 10s max.			350	$^\circ\text{C}$
Temperature, junction ¹	T_J		150	$^\circ\text{C}$
Temperature, storage		-65	+150	$^\circ\text{C}$
Operating Temperature Range, case	T_C	-55	+125	$^\circ\text{C}$

1. Long term operation at the maximum junction temperature will result in reduced product life. Derate internal power dissipation to achieve high MTTF (Mean Time to Failure).

CAUTION

The PB50 is constructed from MOSFET transistors. ESD handling procedures must be observed. The internal substrate contains beryllia (BeO). Do not break the seal. If accidentally broken, do not crush, machine, or subject to temperatures in excess of 850°C to avoid generating toxic fumes.

INPUT

Parameter	Test Conditions	Min	Typ	Max	Units
Offset Voltage, initial			± 0.75	± 1.75	V
Offset Voltage vs. temperature	Full temp range		-4.5	-7	mV/ $^\circ\text{C}$
Input Impedance, DC		25	50		k Ω
Input Capacitance			3		pF
Closed Loop Gain Range		3	10	25	V/V
Gain Accuracy, internal R_g , R_f	$A_V = 3$		± 10	± 15	%
Gain Accuracy, external R_f	$A_V = 10$		± 15	± 25	%
Phase Shift	$F = 10$ kHz, $A_{V_{CL}} = 10$, $C_C = 22$ pF		10		$^\circ$
	$F = 200$ kHz, $A_{V_{CL}} = 10$, $C_C = 22$ pF		60		$^\circ$

OUTPUT

Parameter	Test Conditions	Min	Typ	Max	Units
Voltage Swing	$I_o = 2A$	$\pm V_S - 11$	$\pm V_S - 9$		V
Voltage Swing	$I_o = 1A$	$\pm V_S - 10$	$\pm V_S - 7$		V
Voltage Swing	$I_o = 0.1A$	$\pm V_S - 8$	$\pm V_S - 5$		V
Current, continuous		2			A
Slew Rate	Full temp range	50	100		V/ μ s
Capacitive Load	Full temp range		2200		pF
Settling Time to 0.1%	$R_L = 100 \Omega$, 2V step		2		μ s
Power Bandwidth	$V_C = 100V_{pp}$	160	320		kHz
Small Signal Bandwidth	$C_C = 22pF$, $A_V = 25$, $\pm V_S = \pm 100V$		100		kHz
Small Signal Bandwidth	$C_C = 22pF$, $A_V = 3$, $\pm V_S = \pm 30V$		1		MHz

POWER SUPPLY

Parameter	Test Conditions	Min	Typ	Max	Units
Voltage, $\pm V_S$ ¹	Full temp range	± 30 ²	± 60	± 100	V
Current, quiescent	$V_S = \pm 30$		9	12	mA
	$V_S = \pm 60$		12	18	mA
	$V_S = \pm 100$		17	25	mA

1. $+V_S$ and $-V_S$ denote the positive and negative supply rail respectively.
2. $+V_S$ must be at least 15V above COM, $-V_S$ must be at least 30V below COM.

THERMAL

Parameter	Test Conditions	Min	Typ	Max	Units
Resistance, AC junction to case ¹	Full temp range, $F > 60$ Hz		1.8	2	$^{\circ}C/W$
Resistance, DC junction to case	Full temp range, $F < 60$ Hz		3.2	3.5	$^{\circ}C/W$
Resistance, junction to air	Full temp range		30		$^{\circ}C/W$
Temperature Range, case	Meets full range specifications	-25	25	85	$^{\circ}C$

1. Rating applies if the output current alternates between both output transistors at a rate faster than 60 Hz.

TYPICAL PERFORMANCE GRAPHS

Figure 3: Power Derating

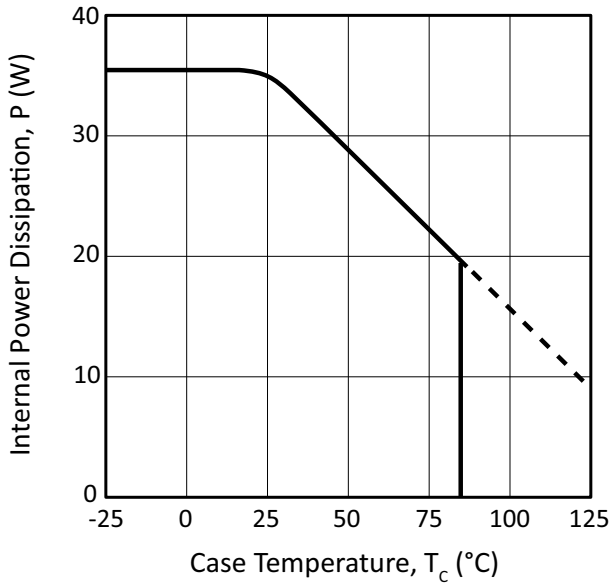

Figure 4: Current Limit

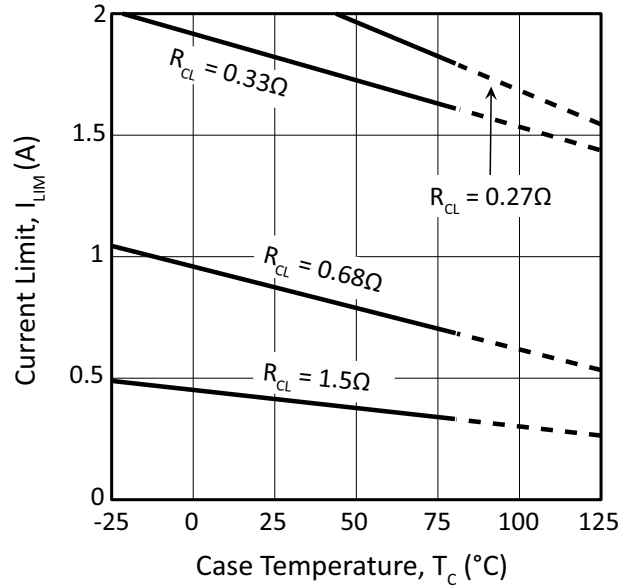

Figure 5: Output Voltage Swing

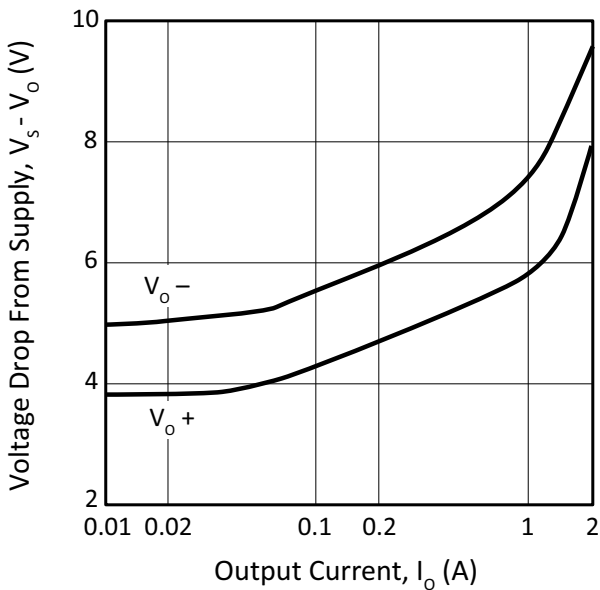
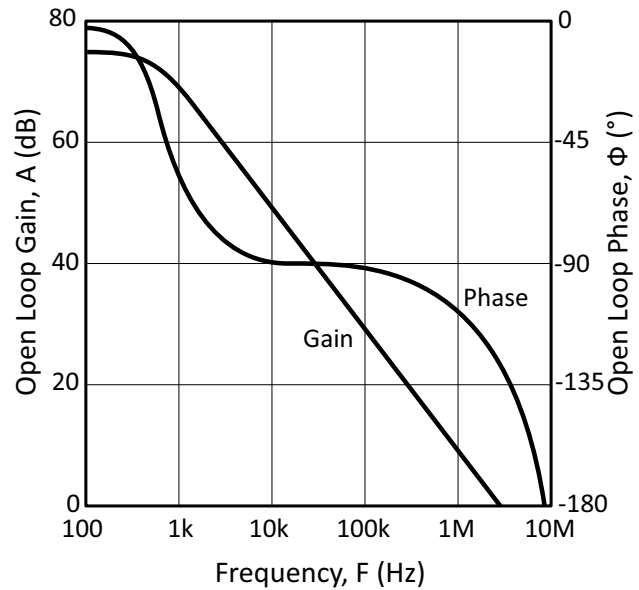
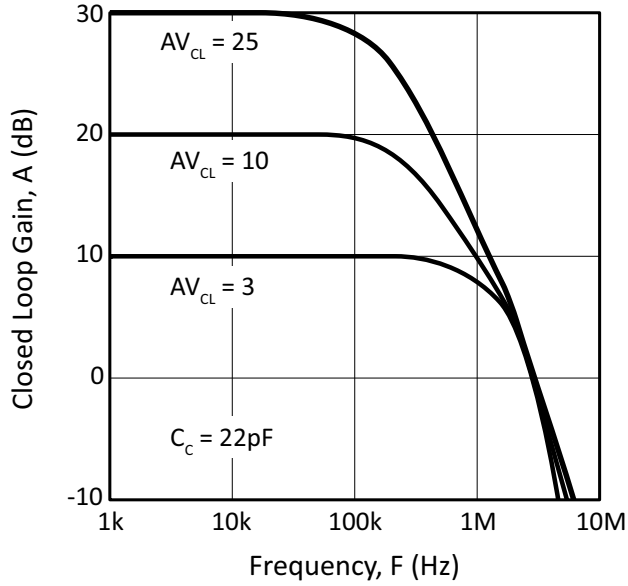

Figure 6: Small Signal Response (Open Loop Gain and Phase)



**Figure 7: Small Signal Response
 (Closed Loop Gain)**



**Figure 8: Small Signal Response
 (Closed Loop Phase)**

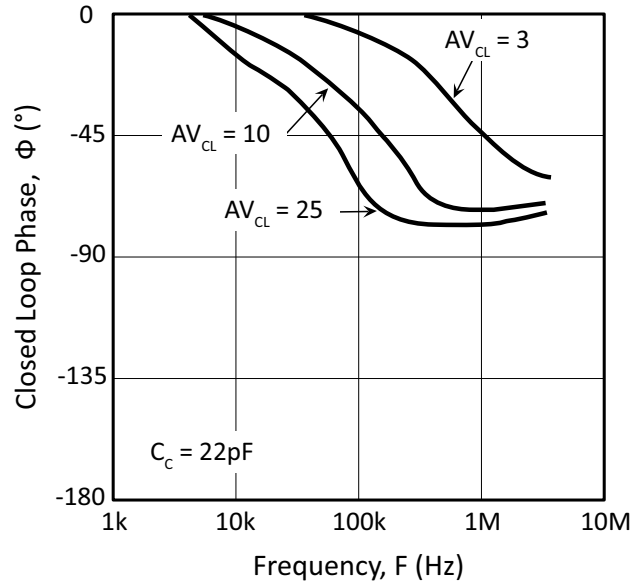

Figure 9: Quiescent Current

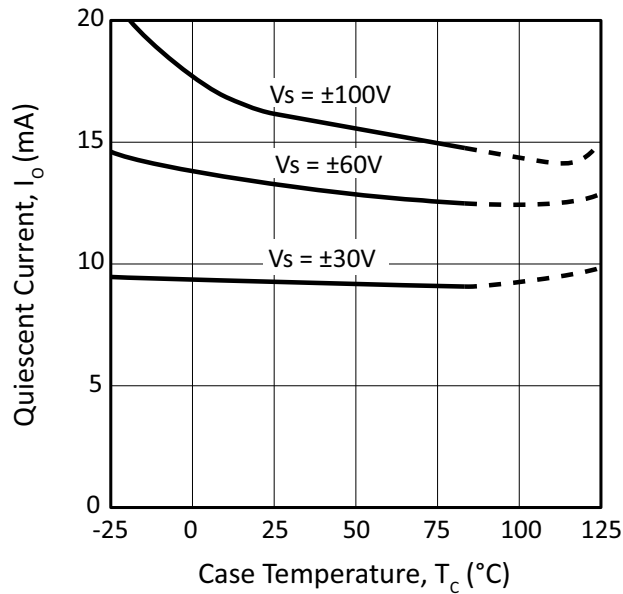

Figure 10: Input Offset Voltage

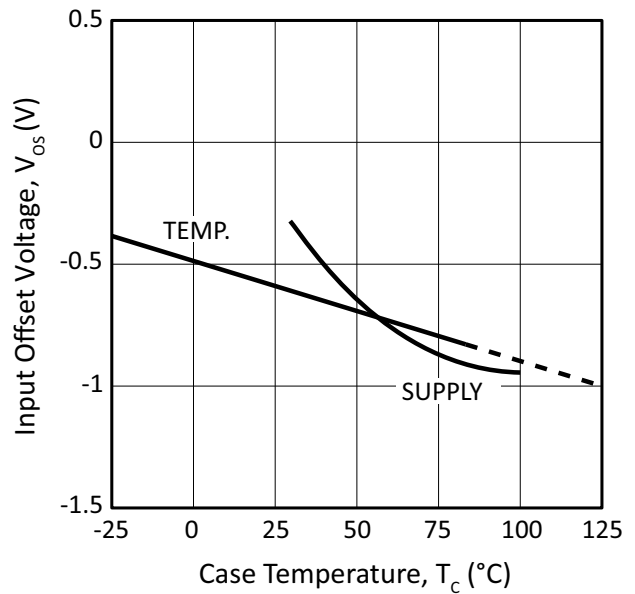

Figure 11: Slew Rate vs. Temperature

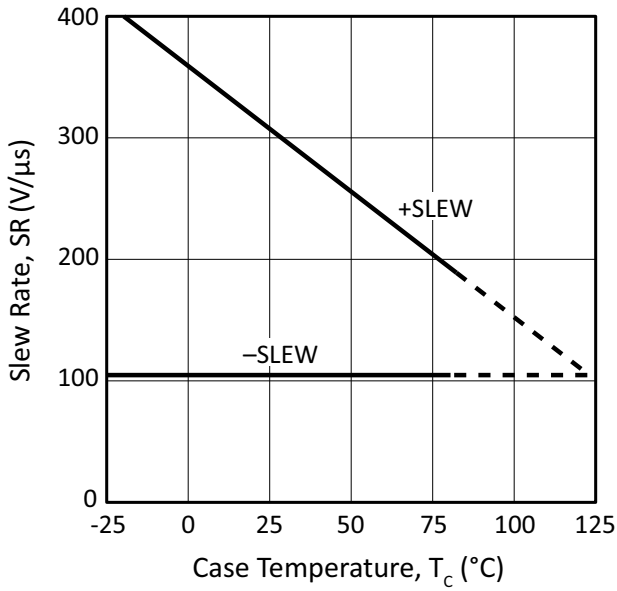

Figure 12: Power Response

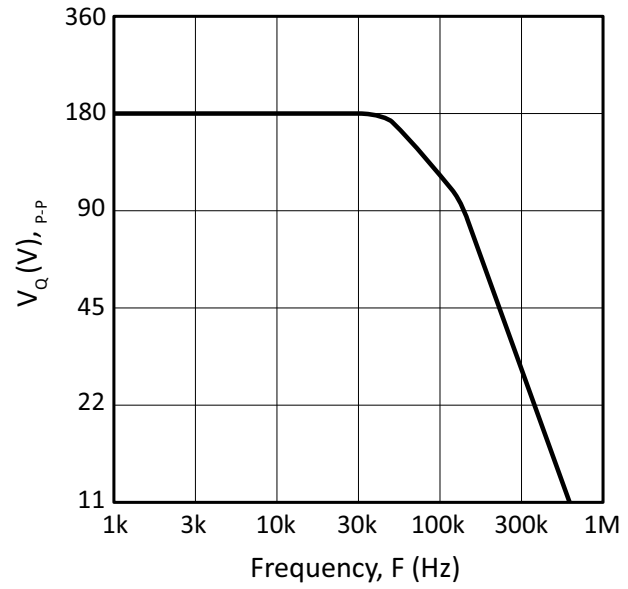

Figure 13: Harmonic Distortion (No Driver)

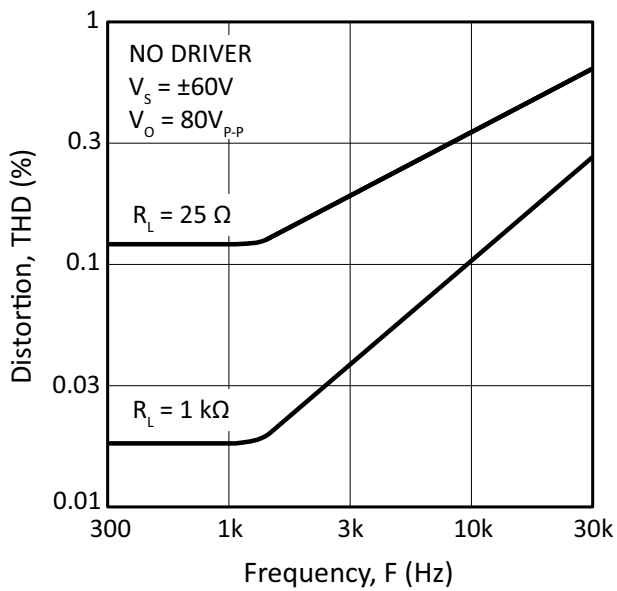
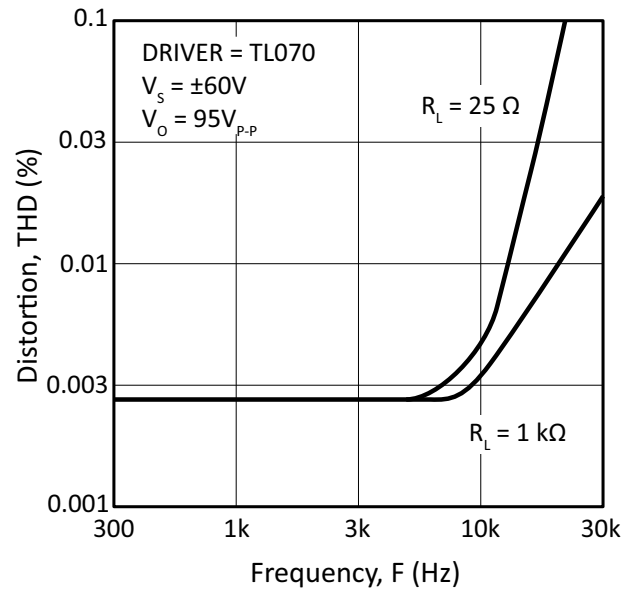

Figure 14: Harmonic Distortion



SAFE OPERATING AREA (SOA)

Note: The output stage is protected against transient flyback. However, for protection against sustained, high energy flyback, external fast-recovery diodes should be used.

Figure 15: SOA

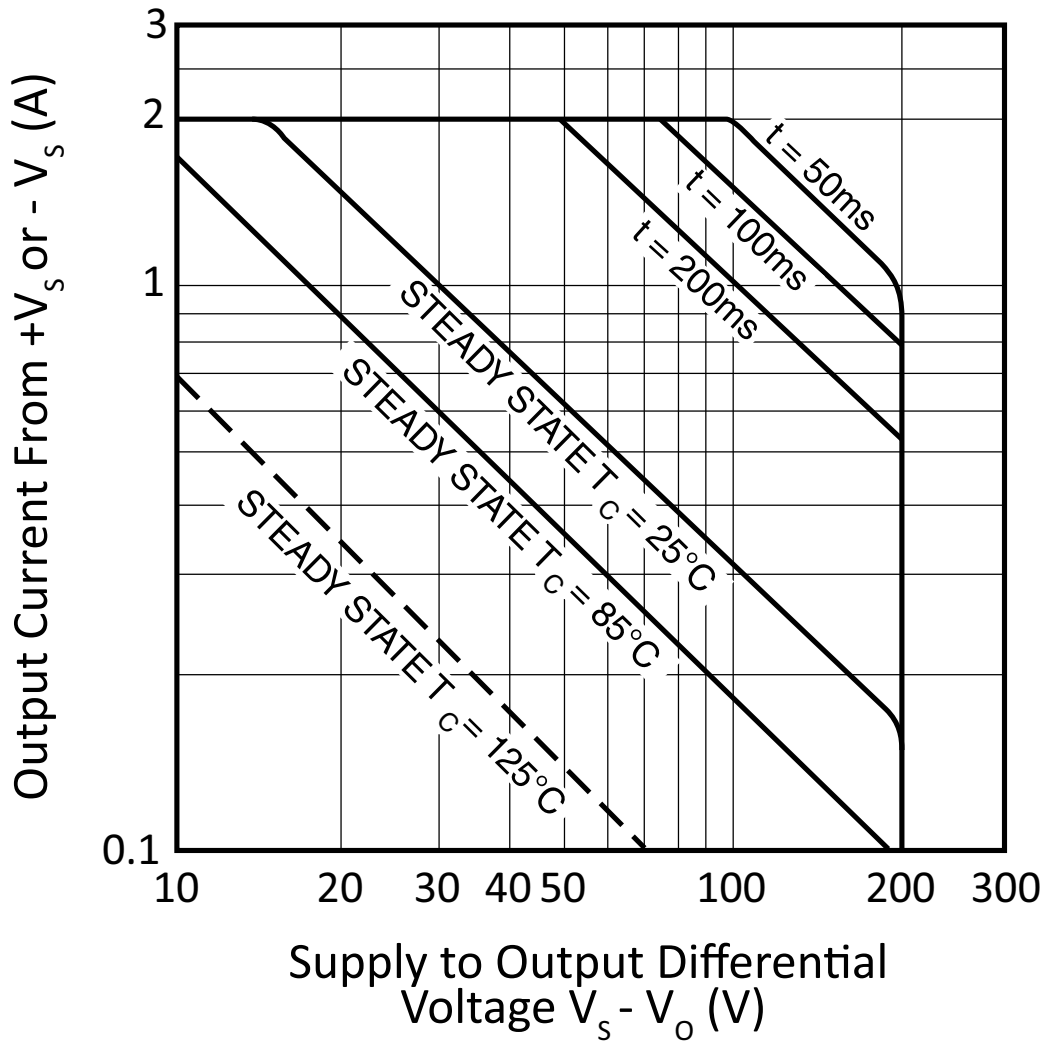

GENERAL

Please read Application Note 1 “General Operating Considerations” which covers stability, supplies, heat sinking, mounting, current limit, SOA interpretation, and specification interpretation. Visit www.apexanalog.com for Apex Microtechnology’s complete Application Notes library, Technical Seminar Workbook, and Evaluation Kits.

TYPICAL APPLICATIONS

Figure 16: Typical Applications

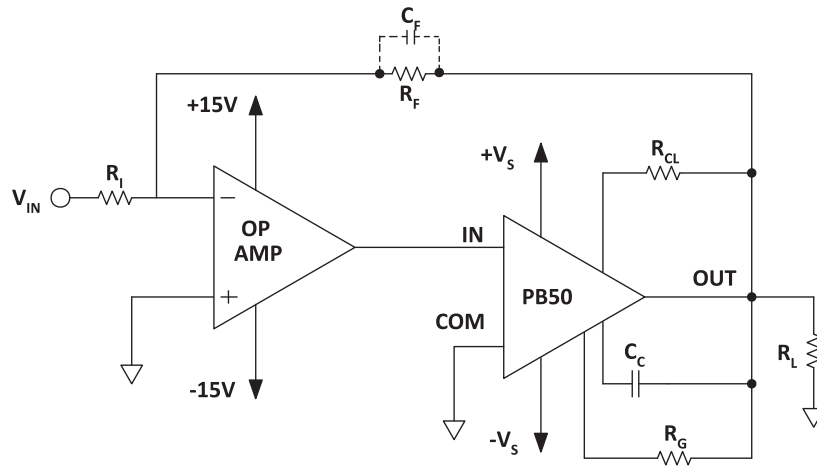

CURRENT LIMIT

For proper operation, the current limit resistor (R_{CL}) must be connected as shown in the typical connection diagram. The minimum value is 0.27Ω with a maximum practical value of 47Ω . For optimum reliability the resistor value should be set as high as possible. The value is calculated as follows: $+I_L =$

$$I_{CL} = \frac{0.65V}{R_{CL}} + 0.01A \quad -I_{CL} = \frac{0.65V}{R_{CL}}$$

COMPOSITE AMPLIFIER CONSIDERATIONS

Cascading two amplifiers within a feedback loop has many advantages, but also requires careful consideration of several amplifier and system parameters. The most important of these are gain, stability, slew rate, and output swing of the driver. Operating the booster amplifier in higher gains results in a higher slew rate and lower output swing requirement for the driver, but makes stability more difficult to achieve.

GAIN SET

$$R_G = [(Av - 1) \cdot 3.1k] - 6.2k$$

$$Av = \frac{R_G + 6.2k}{3.1k} + 1$$

The booster’s closed-loop gain is given by the equation above. The composite amplifier’s closed loop gain is determined by the feedback network, that is: $-R_f/R_i$ (inverting) or $1+R_f/R_i$ (non-inverting). The driver amplifier’s “effective gain” is equal to the composite gain divided by the booster gain.

Example: Inverting configuration (figure 1) with

- R i = 2 k, R f = 60 k, R gain = 0:
- Av (booster) = $(6.2 k/3.1 k) + 1 = 3$
- Av (composite) = $60 k / 2 k = - 30$
- Av (driver) = $- 30/3 = -10$

STABILITY

Stability can be maximized by observing the following guidelines:

1. Operate the booster in the lowest practical gain.
2. Operate the driver amplifier in the highest practical effective gain.
3. Keep gain-bandwidth product of the driver lower than the closed loop bandwidth of the booster.
4. Minimize phase shift within the loop.

A good compromise for (1) and (2) is to set booster gain from 3 to 10 with total (composite) gain at least a factor of 3 times booster gain. Guideline (3) implies compensating the driver as required in low composite gain configurations. Phase shift within the loop (4) is minimized through use of booster and loop compensation capacitors Cc and Cf when required. Typical values are 5pF to 33pF.

Stability is the most difficult to achieve in a configuration where driver effective gain is unity (ie; total gain = booster gain). For this situation, Table 1 gives compensation values for optimum square wave response with the op amp drivers listed.

TABLE 1: TYPICAL VALUES FOR CASE WHERE OP AMP EFFECTIVE GAIN = 1.

DRIVER	C _{CH}	C _F	C _C	FPBW	SR
OP07	-	22p	22p	4kHz	1.5
741	-	18p	10p	20kHz	7
LF155	-	4.7p	10p	60kHz	>60
LF156	-	4.7p	10p	80kHz	>60
TL070	22p	15p	10p	80kHz	>60
For: R _F = 33 k, R _I = 3.3 k, R _G = 22 k					

Figure 17: Non-inverting Composite Amplifier

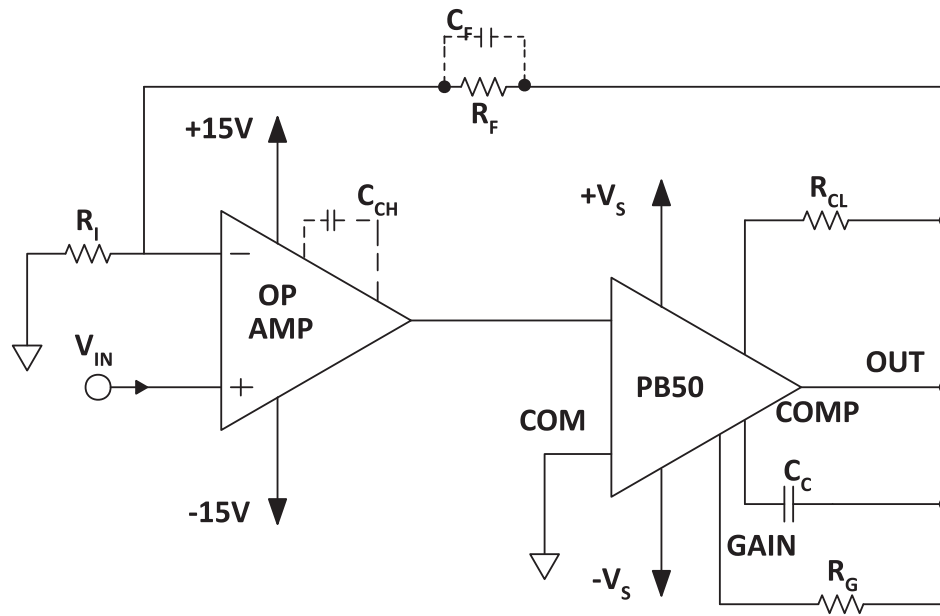

SLEW RATE

The slew rate of the composite amplifier is equal to the slew rate of the driver times the booster gain, with a maximum value equal to the booster slew rate.

OUTPUT SWING

The maximum output voltage swing required from the driver op amp is equal to the maximum output swing from the booster divided by the booster gain. The V_{OS} of the booster must also be supplied by the driver, and should be subtracted from the available swing range of the driver. Note also that effects of V_{OS} drift and booster gain accuracy should be considered when calculating maximum available driver swing.

PACKAGE OPTIONS

PACKAGE STYLE CE

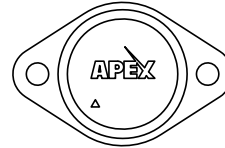
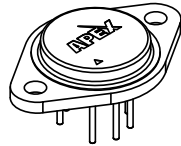

Ordinate dimensions for CAD layout

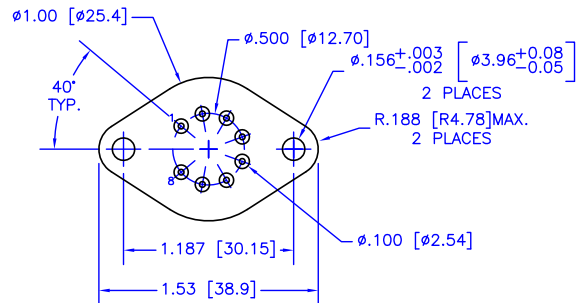
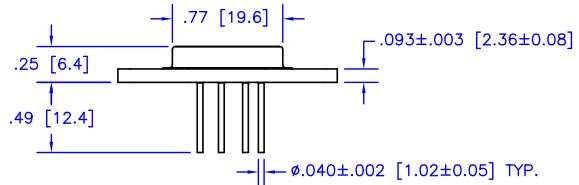
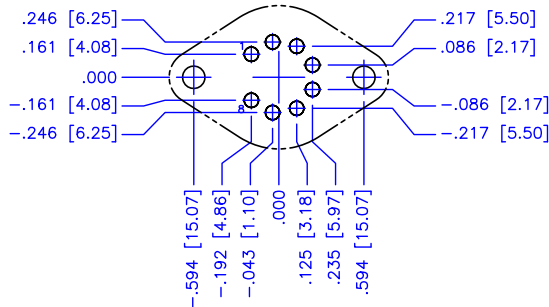

NOTES:

1. Dimensions are inches & [mm].
2. Triangle printed on lid denotes pin 1.
3. Header flatness within pin circle is .0005" TIR, max.
4. Header flatness between mounting holes is .0015" TIR, max.
5. Standard pin material: Solderable nickel-plated Alloy 52.
6. Header material: Nickel-plated cold-rolled steel.
7. Welded hermetic package seal
8. Isolation: 500 VDC any pin to case.
9. Package weight: .53 oz [15 g]

NEED TECHNICAL HELP? CONTACT APEX SUPPORT!

For all Apex Microtechnology product questions and inquiries, call toll free 800-546-2739 in North America. For inquiries via email, please contact apex.support@apexanalog.com. International customers can also request support by contacting their local Apex Microtechnology Sales Representative. To find the one nearest to you, go to www.apexanalog.com

IMPORTANT NOTICE

Apex Microtechnology, Inc. has made every effort to insure the accuracy of the content contained in this document. However, the information is subject to change without notice and is provided "AS IS" without warranty of any kind (expressed or implied). Apex Microtechnology reserves the right to make changes without further notice to any specifications or products mentioned herein to improve reliability. This document is the property of Apex Microtechnology and by furnishing this information, Apex Microtechnology grants no license, expressed or implied under any patents, mask work rights, copyrights, trademarks, trade secrets or other intellectual property rights. Apex Microtechnology owns the copyrights associated with the information contained herein and gives consent for copies to be made of the information only for use within your organization with respect to Apex Microtechnology integrated circuits or other products of Apex Microtechnology. This consent does not extend to other copying such as copying for general distribution, advertising or promotional purposes, or for creating any work for resale.

APEX MICROTECHNOLOGY PRODUCTS ARE NOT DESIGNED, AUTHORIZED OR WARRANTED TO BE SUITABLE FOR USE IN PRODUCTS USED FOR LIFE SUPPORT, AUTOMOTIVE SAFETY, SECURITY DEVICES, OR OTHER CRITICAL APPLICATIONS. PRODUCTS IN SUCH APPLICATIONS ARE UNDERSTOOD TO BE FULLY AT THE CUSTOMER OR THE CUSTOMER'S RISK.

Apex Microtechnology, Apex and Apex Precision Power are trademarks of Apex Microtechnology, Inc. All other corporate names noted herein may be trademarks of their respective holders.

X-ON Electronics

Largest Supplier of Electrical and Electronic Components

Click to view similar products for [Operational Amplifiers - Op Amps](#) category:

Click to view products by [Apex Microtechnology](#) manufacturer:

Other Similar products are found below :

[LM258AYDT](#) [LM358SNG](#) [430227FB](#) [UPC824G2-A](#) [LT1678IS8](#) [042225DB](#) [058184EB](#) [UPC259G2-A](#) [NTE925](#) [AZV358MTR-G1](#)
[AP4310AUMTR-AG1](#) [HA1630D02MMEL-E](#) [HA1630S01LPEL-E](#) [NJU77806F3-TE1](#) [NCV20034DR2G](#) [LM324EDR2G](#) [LM2902EDR2G](#)
[NTE778S](#) [NTE871](#) [NTE924](#) [NTE937](#) [MCP6V17T-E/MNY](#) [MCP6V19-E/ST](#) [MCP6V36UT-E/LTY](#) [MXD8011HF](#) [SCY6358ADR2G](#)
[LTC2065HUD#PBF](#) [NJM2904CRB1-TE1](#) [2SD965T-R](#) [RS6332PXK](#) [BDM8551](#) [BDM321](#) [MD1324](#) [COS8052SR](#) [COS8552SR](#) [COS8554SR](#)
[COS2353SR](#) [COS724TR](#) [ASOPD4580S-R](#) [RS321BKXF](#) [ADA4097-1HUIZ-RL7](#) [NCV4333DTBR2G](#) [EL5420CRZ-T7A](#) [AS324MTR-E1](#)
[AS358MMTR-G1](#) [MCP6472T-E/MS](#) [MCP6491T-ELTY](#) [MCP662-E/MF](#) [TLC073IDGQR](#) [TLC081AIP](#)