



Weller®



WXR 3

- DE** Originalbetriebsanleitung
GB Translation of the original instructions
ES Traducción del manual original
FR Traduction de la notice originale
IT Traduzione delle istruzioni originali
PT Tradução do manual original
NL Vertaling van de oorspronkelijke gebruiksaanwijzing
SV Översättning av bruksanvisning i original
DK Oversættelse af den originale brugsanvisning
FI Alkuperäisten ohjeiden käännös
GR Μετάφραση του πρωτοτύπου των οδηγιών χρήσης
TR Orijinal işletme talimatı çevirisi
- CZ** Překlad původního návodu k používání
PL Tłumaczeniem instrukcji oryginalnej
HU Eredeti használati utasítás fordítása
SK Preklad pôvodného návodu na použitie
SL Prevod izvirnih navodil
EE algupärase kasutusjuhendi tõlge
LV Instrukciju tulkojumam no oriģinālvalodas
LT Originalios instrukcijos vertimas
BG Превод на оригиналната инструкция
RO Traducere a instructiunilor originale
HR Prijevod originalnih uputa
RU Оригинальное руководство по эксплуатации

Air

WXHAP 200

Water



WXP 65



WXP 120



WXP 200

Vac



WXMT



WXDV 120



WXDP 120

WX



Air **Vac**

400 380 350
WXP 200 WXP 120 WXP 65

Weller
Made in Germany

ON / OFF
I / O

Diagram description: A central Weller WXR 3 control unit is shown. It features three input ports labeled r-1, r-2, and r-3. Below these are three buttons labeled Air, Vac, and Pick Up. A power switch with a power icon and 'ON / OFF I / O' text is located on the right side. A power cord with a lightning bolt icon is plugged into the top right. Lines connect the three input ports to the three boxes above. Lines connect the Air, Vac, and Pick Up buttons to the 'Pick Up' box below. A power icon is also connected to the power switch.

Pick Up



WVP



WRK

Quick Reference WXR 3

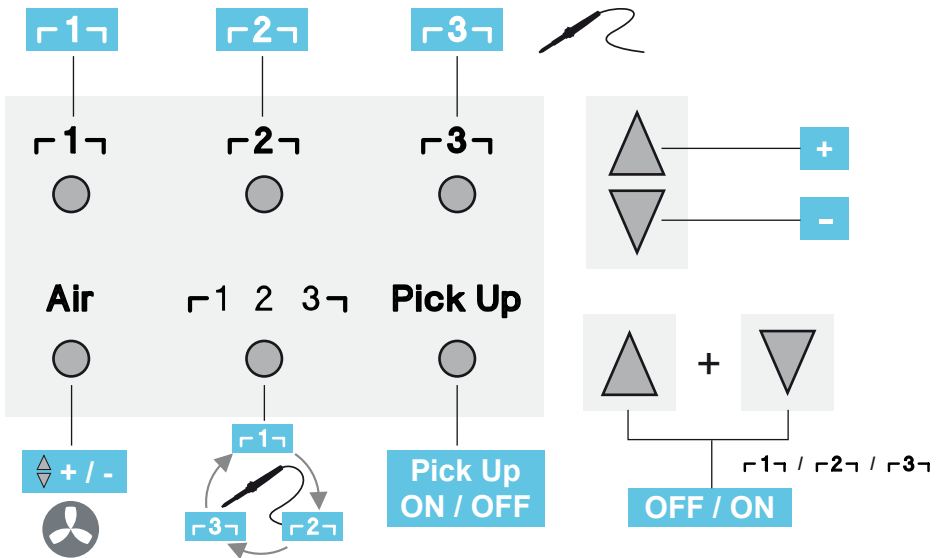

DE Menüaufruf
 GB Open Menu
 ES Acceso al Menú
 FR Appel du menu
 IT Richiama il menu
 PT Activação do menu
 NL Oproep Menu
 SV Öppna menyn

DK Hentning af menu
 FI Valikon haku näyttöön
 GR Κλήση μενού
 TR Menüsinü açma
 CZ Spuštění Nabídky položek
 PL Wywołanie menu
 HU Menü előhívása
 SK Vyvolanie menu

SL Priklic menija
 EE Menüü avamine
 LV Izvēlnes izsaukšana
 LT Meniu iškvietia
 BG Повикване на менюто
 RO Apelarea meniului
 HR Pozivanje izbornika
 RU ВЫЗОВ МЕНЮ

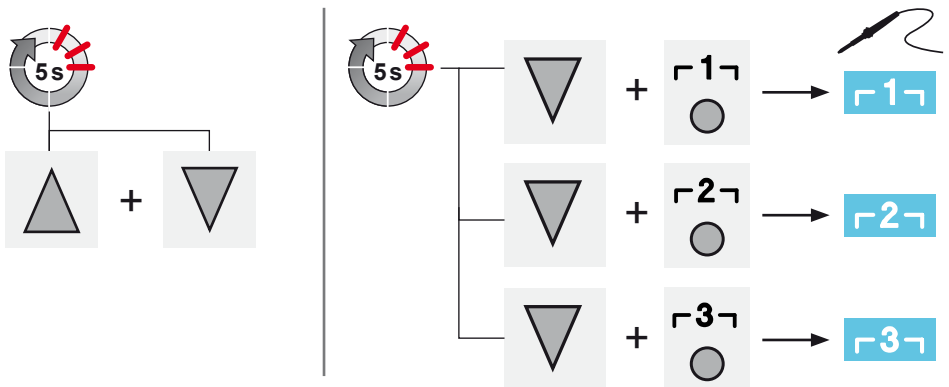

DE Lieferumfang
 GB Included in delivery
 ES Piezas suministradas
 FR Fourniture
 IT Dotazione
 PT Fornecimento
 NL Meegeleverd van de levering
 SV Leveransomfattning

DK Leveringsomfang
 FI Toimitussisältö
 GR Υλικά παράδοσης
 TR Teslimat kapsamı
 CZ Rozsah dodávky
 PL Zakres dostawy
 HU Szállítási terjedelem
 SK Rozsah dodávky

SL Obseg pošiljke
 EE Tame sisu
 LV Piegādes komplekts
 LT Komplektas
 BG Обем на доставката
 RO Pachetul de livrare
 HR Popratna oprema
 RU Комплект поставки



DE Zubehör
 GB Accessory
 ES Accesorio
 FR Accessoires
 IT Accessorio
 PT Acessório
 NL Toebehoren
 SV Tillbehör

DK Tilbehør
 FI Lisälaite
 GR Εξαρτήματα
 TR Aksesuar
 CZ Příslušenství
 PL Wyposażenie
 HU Tartozékok
 SK Príslušenstvo

SL Oprema
 EE Tarvikud
 LV Piederumi
 LT Priedas
 BG Принадлежности
 RO Accesorii
 HR Pribor
 RU Оснастка



PC
 T005 87 647 11



WFE/WHP
 T005 87 647 12



WX
 T005 87 647 10



WX Hub
 T005 87 647 26



WX Foot switch
 T005 87 647 46



WXS B 200



WHP 1000
 WHP 3000, 600 W
 WHP 3000, 1200 W
 WXHP 120, 120 W



Zero Smog 6V / WFE 4S
 Zero Smog 20T / WFE 20D
 Zero Smog 4V



WFV 60A
 T005 87 627 46

DE Inbetriebnahme
 GB Starting up the device
 ES Puesta en servicio del aparato
 FR Mise en service de l'appareil
 IT Messa in funzione dell'apparecchio
 PT Colocação do aparelho em serviço
 NL Toestel in gebruik nemen
 SV Ta lödstationen i drift
 DK Ibrugtagning af apparatet
 FI Laitteen käyttöönotto
 GR Θέση της συσκευής σε λειτουργία
 TR Cihazı işletime alma

CZ Uvedení zařízení do provozu
 PL Uruchamianie urządzenia
 HU A készülék üzembe helyezésé
 SK Uvedenie zariadenia do prevádzky
 SL Začetek dela z napravo
 EE Seadme kasutuselevõtt
 LV Iekārtas lietošanas sākšana
 LT Prietaiso paruošimas eksploatuoti
 BG Включване на уреда
 RO Punerea în funcțiune a aparatului
 HR Uređaj pustiti u rad
 RU Ввод устройства в эксплуатацию

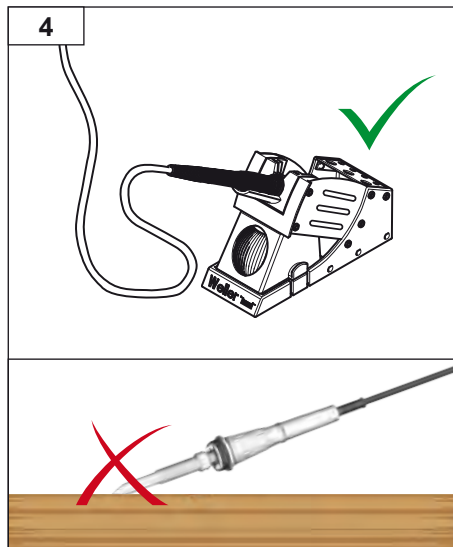
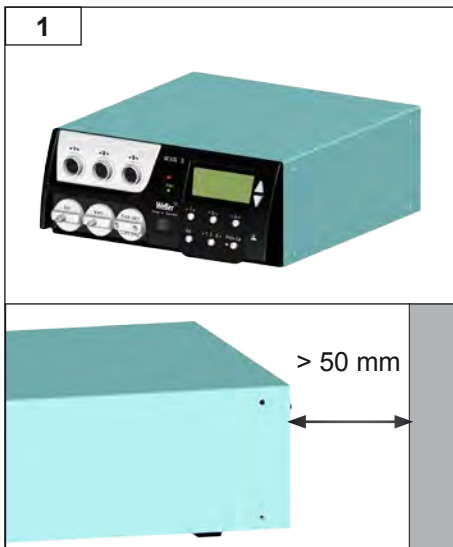

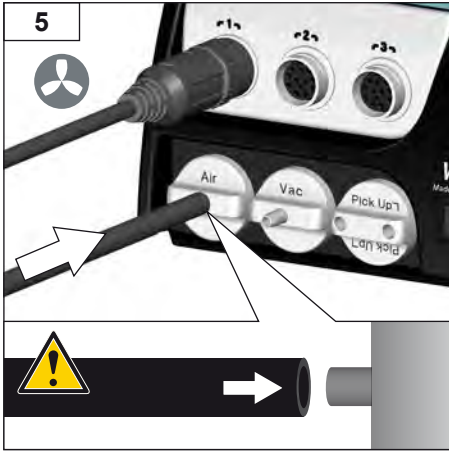

TIP



WXHAP 200

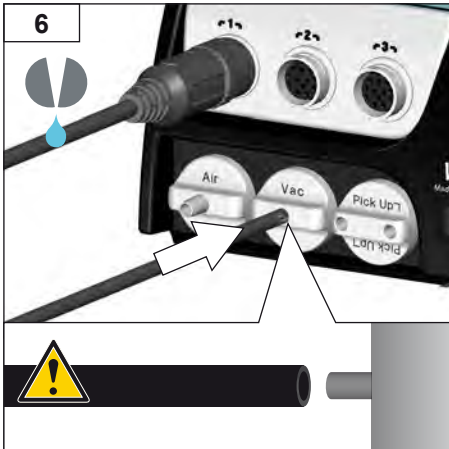

TIP



WXDP 120



WXDV 120

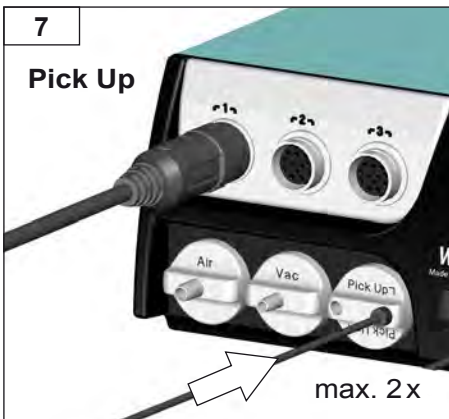

TIP



WVP



WRK

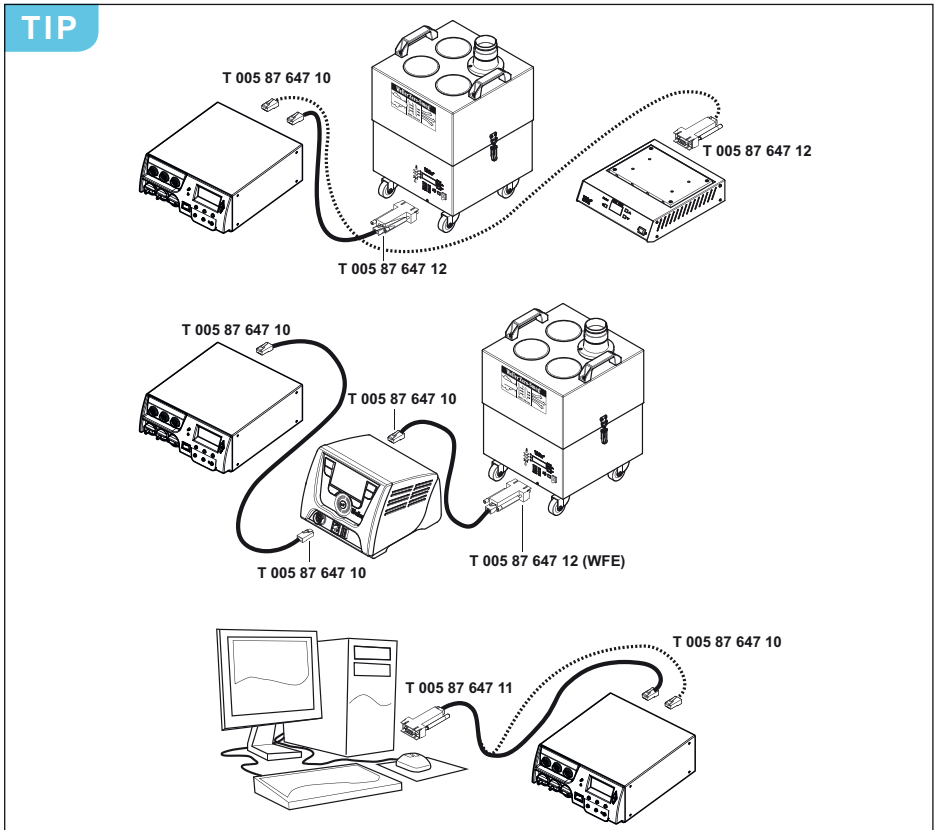
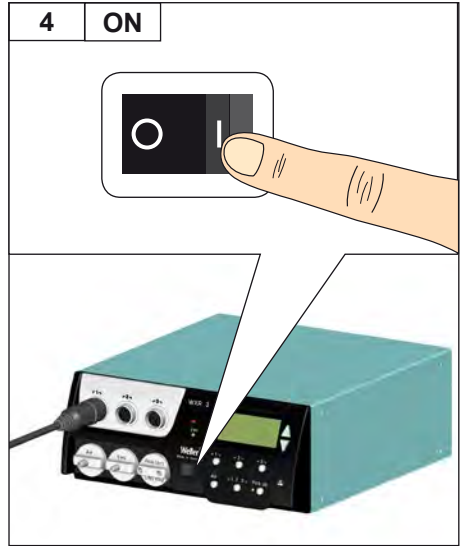
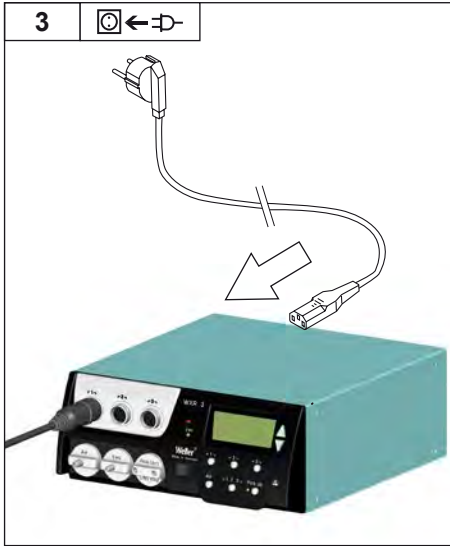

DE Filterwechsel
 GB Filter change
 ES Cambio de filtro
 FR Remplacement du filtre
 IT Sostituzione del filtro
 PT Troca do filtro
 NL Wissel van de filter
 SV Byte av filter
 DK Filterskift
 FI Suodattimen vaihto
 GR Αλλαγή φίλτρου
 TR Filtre deęişimi

CZ Výměna filtru
 PL Wymiana filtra
 HU Szűrőcsere
 SK Výmena filtra
 SL Menjava filtra
 EE Filtri vahetamine
 LV Filtra nomaiņa
 LT Filtrų keitimas
 BG Смяна на филтъра
 RO Schimbarea filtrului
 HR Mjenjanje filtra
 RU Замена фильтров

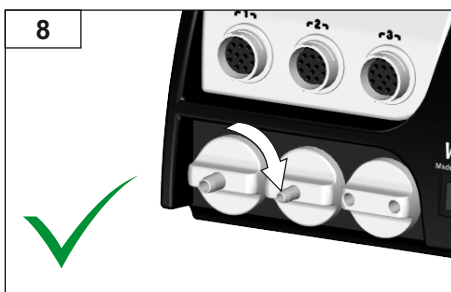
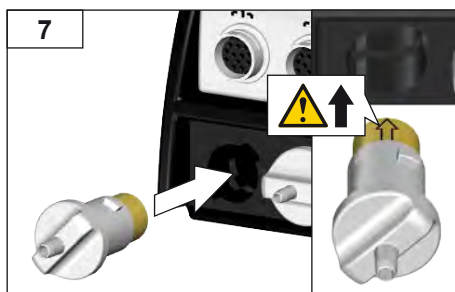
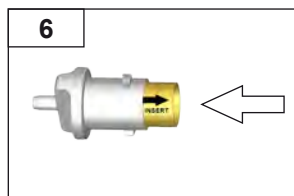
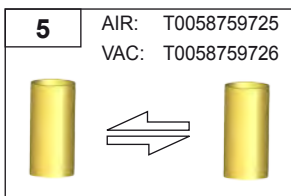
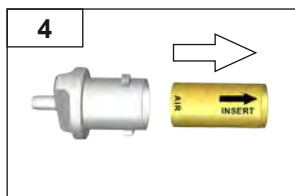
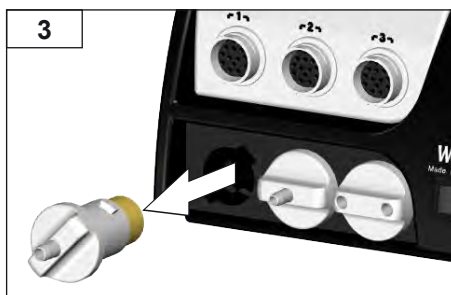
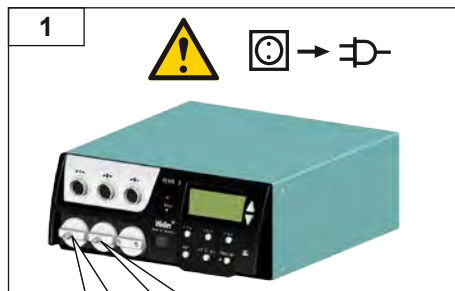

DE Kanal auswählen
 GB Select channel
 ES Seleccionar canal
 FR Sélectionner un canal
 IT Selezione del canale
 PT Seleccionar o canal
 NL Kanaal selecteren
 SV Välj kanal.
 DK Vælg kanal
 FI Kanavan valinta
 GR Επιλογή καναλιού
 TR Kanal seçimi

CZ Volba kanálu
 PL Wybór kanału
 HU Csatorna kiválasztás
 SK Zvoľte kanál
 SL Izbira kanala
 EE kanali valimine
 LV Kanāla izvēle
 LT Pasirinkite kanalą
 BG Изберете канал
 RO Selectarea canalului
 HR Odaberite kanal
 RU Выбор канала



DE Kanal wechseln
 GB Change channel
 ES Cambiar de canal
 FR Changer de canal
 IT Cambio del canale
 PT Mudar o canal
 NL Kanaal wisselen
 SV Byt kanal
 DK Skift kanal
 FI Kanavan vaihto
 GR Αλλαγή καναλιού
 RU Канал дежйtirme

CZ Změna kanálu
 PL Zmiana kanału
 HU Csatornaváltás
 SK Zmeňte kanál
 SL Menjava kanala
 EE kanali vahetamine
 LV Kanāla nomaīņa
 LT Pakeiskite kanalą
 BG Прoмяна на канал
 RO Schimbarea canalului
 HR Promijenite kanal
 RU Смена канала

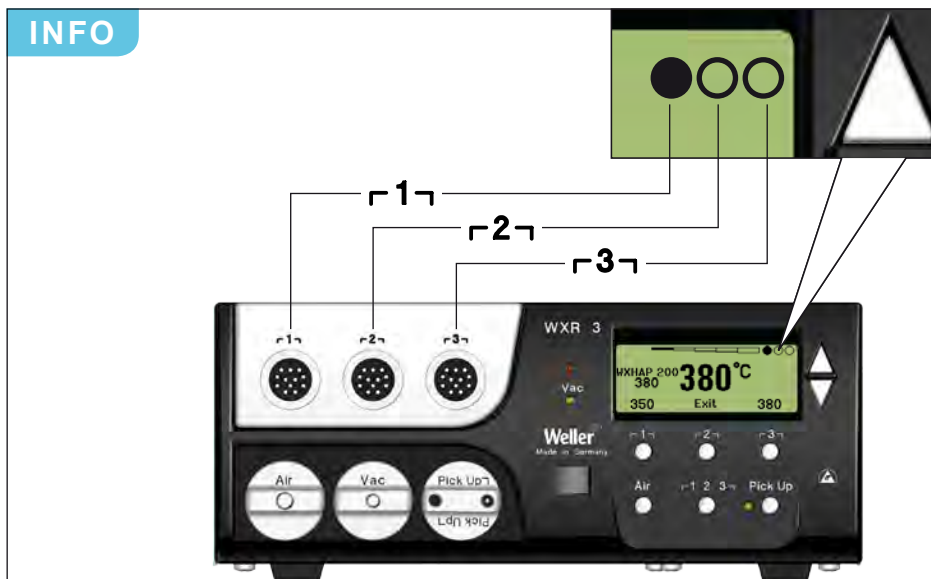

DE Heißluft
 GB Hot air
 ES Aire caliente
 FR Air chaud
 IT Aria calda
 PT Ar quente
 NL Hete lucht
 SV Hetluft
 DK Varmluft
 FI Kuumailma
 GR Καυτός αέρας
 TR Sıcak hava

CZ Horký vzduch
 PL Gorące powietrze
 HU Forrólevegő
 SK Horúci vzduch
 SL Vroč zrak
 EE kuum õhk
 LV Karsts gaiss
 LT Karštas oras
 BG Горещ въздух
 RO Aer cald
 HR Vrući zrak
 RU Нагретый воздух

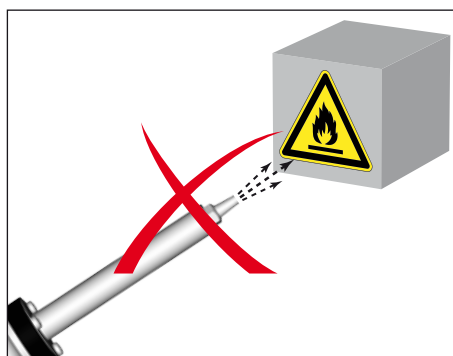
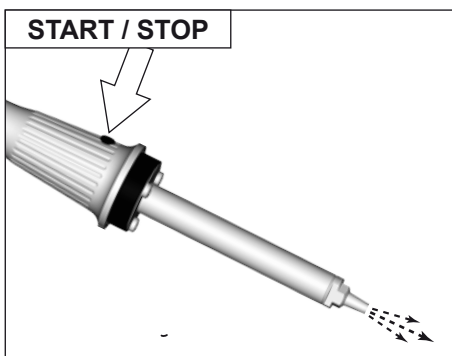
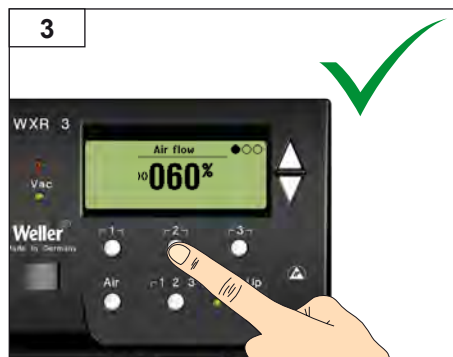
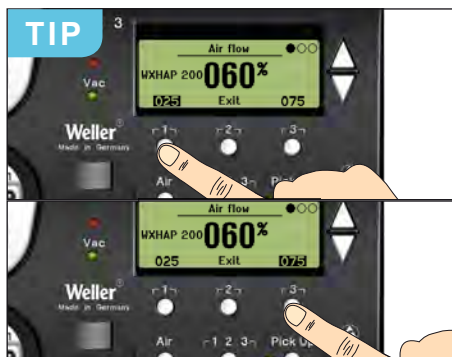
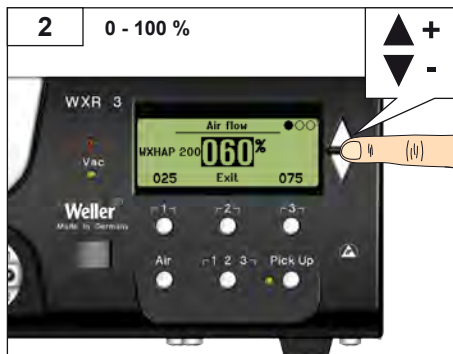

DE Pick Up - Vakuum
 GB PickUp vacuum
 ES Pick Up - Vacío
 FR Pick Up - vide
 IT Vuoto Pick-up
 PT Vácuo PickUp
 NL Pick Up - vacuüm
 SV PickUp-vakuum
 DK Pick Up - vakuum
 FI Pick Up - tyhjiö
 GR Pick Up - Κενό
 RU Kaldırma vakumu

CZ Pick-up vakuom
 PL Pick Up - próżnia
 HU Pick Up - vákuum
 SK Pick Up - vákuum
 SL Pobiranje – podtlak
 EE Pick Up - vaakum
 LV Pacelšana – vakuums
 LT PICK UP vakuumas
 BG колено вакуум
 RO Pick Up - vid
 HR Pick Up - vakuum
 RU Отбор вакуума

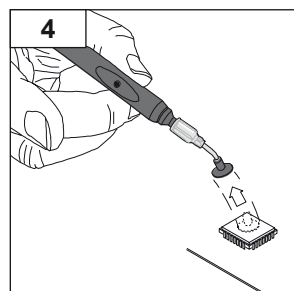
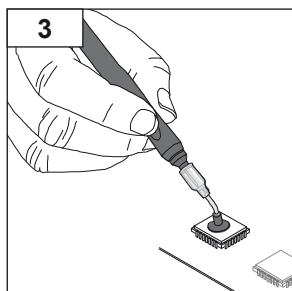
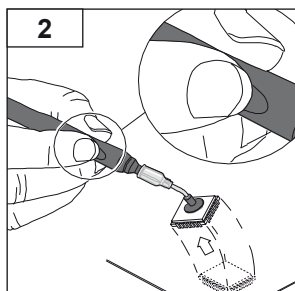
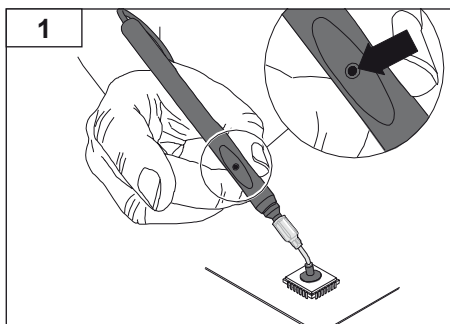
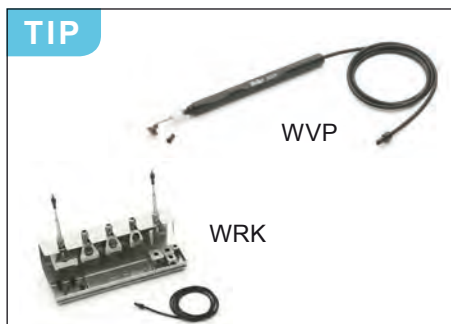

DE Kanal ein-/ ausschalten
 GB Switching the channel on/ off
 ES Conexión/ Desconexión del canal
 FR Activation / désactivation du canal
 IT Attivazione/ Disattivazione di un canale
 PT Desligar/ ligar o canal
 NL Kanaal uit-/ inschakelen
 SV Koppla in/ ur kanal
 DK Deaktivering/ aktivering af kanal
 FI Kanavan pois-/ päällekytkentä
 GR Απενεργοποίηση/ ενεργοποίηση καναλιού
 TR Kanal kapatma/ açma

CZ Vypnutí/ zapnutí kanálu
 PL Włączenie / wyłączenie kanału
 HU Csatorna ki-/ bekapcsolása
 SK Vypnutie/ zapnutie kanálu
 SL Vkllop/ izklop kanala
 EE Kanali välja/ sisselülitamine
 LV Kanālu izslēgšana/ ieslēgšana
 LT Kanalo išjungimas / įjungimas
 BG Вкл- / изключване на канал
 RO Conectarea/deconectarea canalului
 HR Uključivanje/isključivanje kanala
 RU Выключение/включение канала



DE Solltemperatur
 GB Nominal temperature
 ES Temperatura de referencia
 FR Température de consigne
 IT Temperatura nominale
 PT Temperatura nominal
 NL Gewenste temperatuur
 SV Börtemperatur
 DK Nominel temperatur
 FI Ohjelämpötila
 GR Ονομαστική θερμοκρασία
 TR Nominal sıcaklık

CZ Nominal sıcaklık
 PL Temperatura zadana
 HU Temperatura hőmérséklet
 SK Požadovaná teplota
 SL želena temperatura
 EE Sihttemperatuur
 LV Vēlamā temperatūra
 LT Nustatytoji temperatūra
 BG Заддена температура
 RO Temperatura nominală
 HR Zadana temperatura
 RU Заданная температура

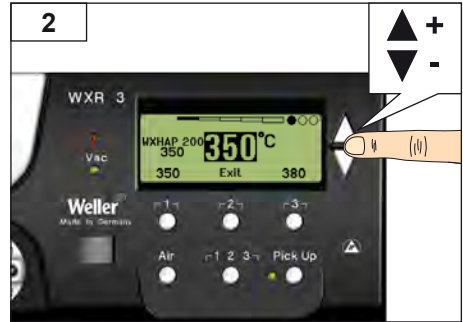

DE Festtemperatur auswählen
 GB Select fixed temperature
 ES Seleccionar un valor fijo de temperatura
 FR Sélectionner la température fixe
 IT Selezione della temperatura fissa
 PT Seleccionar temperatura fixa
 NL Vaste temperatuur selecteren
 SV Välj fast temperatur
 DK Vælg fast temperatur
 FI Kiinteän lämpötilan valinta
 GR Επιλογή της σταθερής θερμοκρασίας
 TR Sabit sıcaklık seçilmesi

CZ Volba pevné teploty
 PL Wybór stałej temperatury
 HU Rögzített hőmérséklet kiválasztása
 SK Zvoľte do pamäte fixnú teplotu
 SL Izbira stalne temperature
 EE Püsitemperatuuri valimine
 LV Fiksētās temperatūras izvēle
 LT Nustatytosios temperatūros parinktis
 BG Избор на непроменлива температура
 RO Selectarea temperaturii fixe
 HR Odabir fiksne temperature
 RU Выбор фиксированной температуры

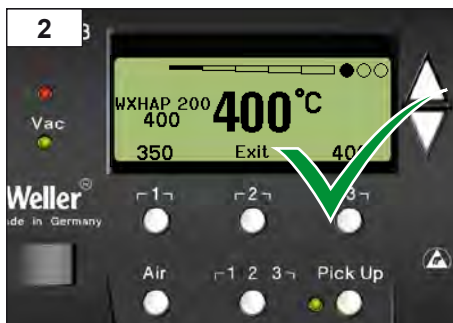

DE Festtemperatur einstellen und speichern
 GB Set and save fixed temperature
 ES Ajustar / guardar un valor fijo de temperatura
 FR Régler et mémoriser la température fixe
 IT Impostazione e memorizzazione della temperatura fissa
 PT Ajustar e memorizar temperatura fixa
 NL Vaste temperatuur instellen en opslaan
 SV Ställ in fast temperatur och spara den
 DK Indstil og gem fast temperatur
 FI Kiinteän lämpötilan säätö ja tallennus
 GR Ρύθμιση / αποθήκευση της σταθερής θερμοκρασίας
 TR Sabit sıcaklık ayarlanmalıdır / kaydedilmelidir
 CZ Nastavení a uložení pevné teploty

PL Ustawianie i zapis stałej temperatury
 HU Rögzített hőmérséklet beállítása / mentése
 SK Nastavte a uložte do fixnú teplotu
 SL Nastavitev stalne temperature in shranitev
 EE Püsitemperatuuri reguleerimine / salvestamine
 LV Fiksētās temperatūras iestatīšana / saglabāšana
 LT Nustatytosios temperatūros nustatymas ir išsaugojimas
 BG Задаване и запамятване на непроменлива температура
 RO Setarea și salvarea temperaturii fixe
 HR Namještanje i spremanje fiksne temperature
 RU Установка и сохранение фиксированной температуры

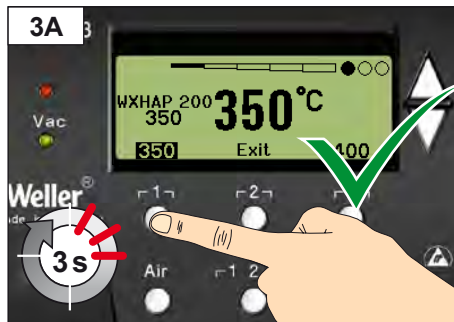
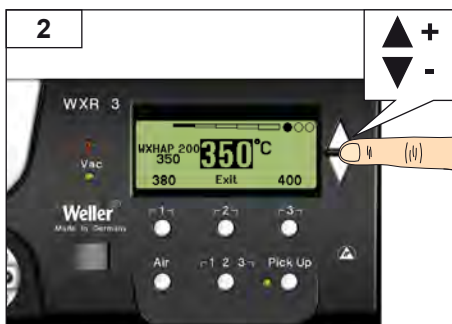
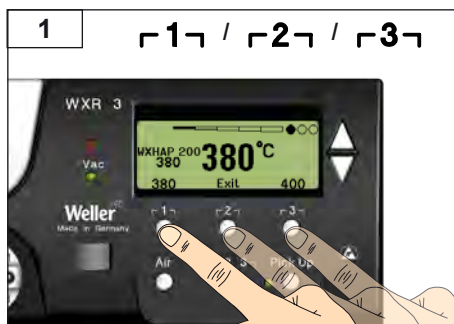

DE	Aufruf Parametermenü	CZ	Spuštění Nabídky položek Parametry
GB	Open Parameter menu	PL	Wywołanie menu parametrów
ES	Acceso al Menú de parámetros	HU	Paramétermenü előhívása
FR	Appel du menu Paramètres	SK	Vývolanie menu parametrov
IT	Richiama il menu Parametri	SL	Priklic menija parametrov
PT	Ativação do menu de parâmetros	EE	Parameetrimenüü avamine
NL	Oproep parametermenu	LV	Parametru izvēlnes izsaukšana
SV	Öppna parametermenyn	LT	Parametrų meniu iškvietia
DK	Hentning af parametermenu	BG	Разпределение на бутоните
FI	Parametrialikon haku näyttöön	RO	Alocarea tastelor
GR	Κλήση μενού των παραμέτρων	HR	Dodjela tipki
TR	Parametre menüsünü açma	RU	Вызов меню параметров

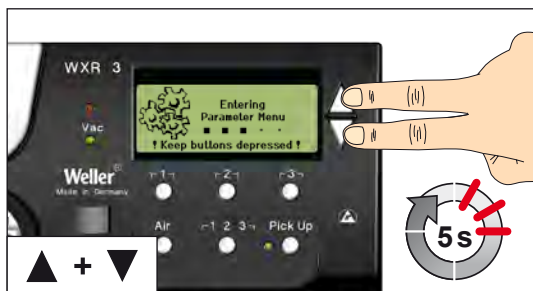

DE Auswahl/Einstellung Wert
 GB Select/set value
 ES Selección/Ajuste del valor
 FR Sélection / réglage valeur
 IT Selezione/Impostazione del valore
 PT Selecção/regulação do valor
 NL Keuze/instelling waarde
 SV Val/inställning av värde
 DK Valg/indstilling værdi
 FI Arvon valinta/asetus
 GR Επιλογή/ρύθμιση τιμής
 TR Değer seçimi/ayarı

CZ Volba/Nastavení Hodnota
 PL Wybór / ustawienie wartości
 HU Érték kiválasztása / beállítás
 SK Výber/nastavenie hodnoty
 SL Izbira/nastavitev vrednosti
 EE Väärtuse valik/seadmine
 LV Vērtības izvēle/iestatīšana
 LT Parinkties / nustatymo vertė
 BG Избор/ настройка стойност
 RO Selectarea/setarea valorii
 HR Odabir/namještanje vrijednosti
 RU Выбор/регулировка значения



DE Parametermenü verlassen
 GB Exit parameter menu
 ES Saldrá del menú de parámetros
 FR Le menu Paramètres est quitté
 IT Il menu Parametri viene terminato
 PT O menu de parâmetros é abandonado
 NL Parametermenu wordt verlaten
 SV Parametermenyn stängs
 DK Parametermenuen forlades
 FI Parametrialikosta poistutaan
 GR Το μενού των παραμέτρων εγκαταλείπεται
 TR Parametre menüsünden çıkılır

CZ Nabídka položek Parametry se ukončí
 PL Następuje wyjście z menu parametrów
 HU Kilépés a paramétermenüből
 SK Opustíte menu parametrov
 SL Zapustili boste meni parametrov.
 EE Väljutakse parameetrimenüüst
 LV Parametru izvēlnē tiek aizvērts
 LT Parametų meniu uždaromas
 BG Излизане от менюто за параметрите
 RO Părăsirea meniului de parametri
 HR Napuštanje Izbornika s parametrima
 RU Выход из меню параметров

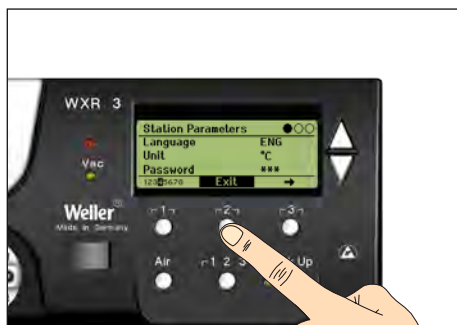

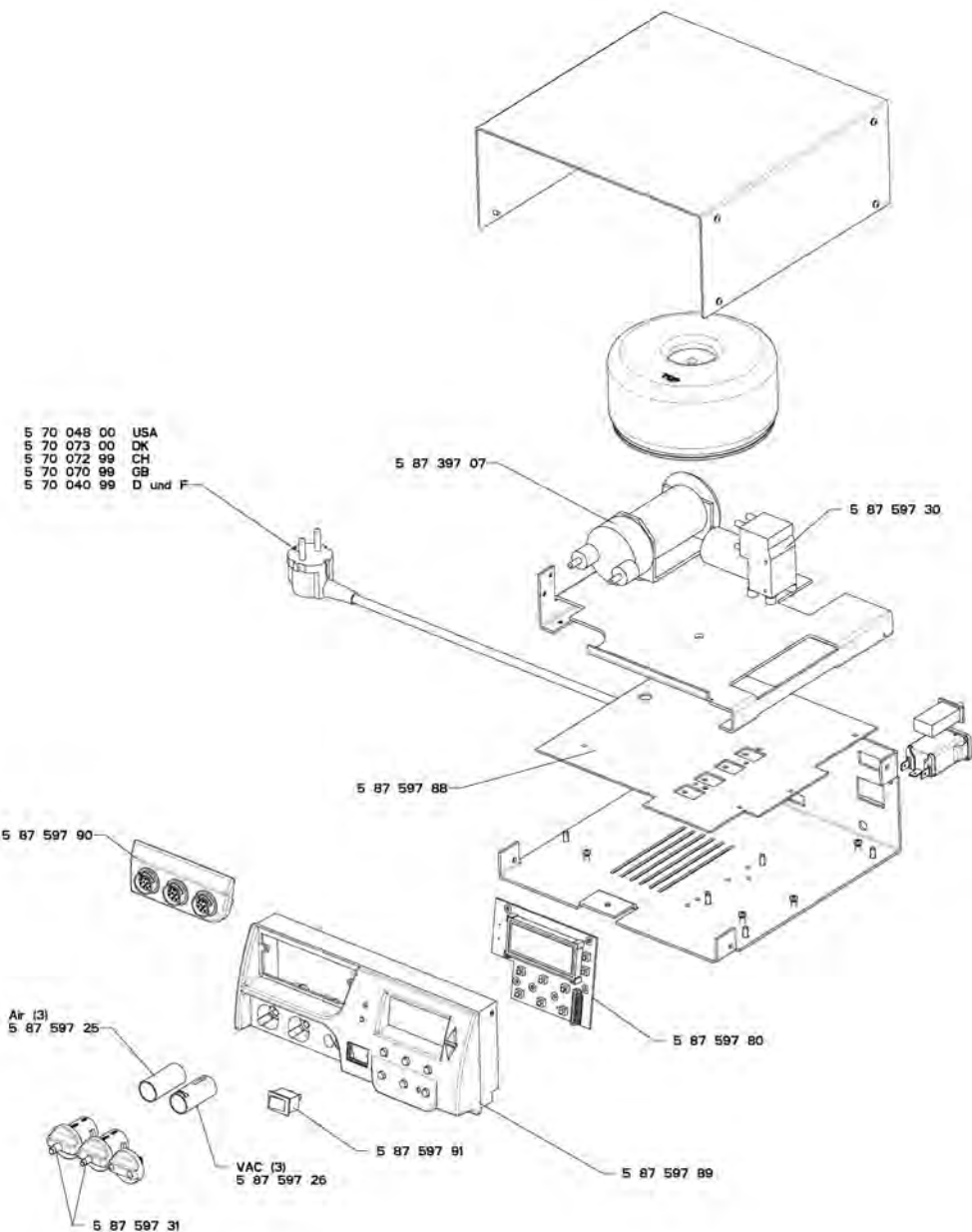

GERMANY

Weller Tools GmbH
Carl-Benz-Straße 2
74354 Besigheim

Tel: +49 (0)7143 580-0
Fax: +49 (0)7143 580-108

SWEDEN

Apex Tool Group AB
Fabriksgatan 4
531 30 Lidköping

Tel: +46 (0) 510 77 71 720

AUSTRALIA

Apex Tools
P.O. Box 366, 519 Nurigong Street
Albury, N.S.W. 2640
Australia

Tel: +61 (2)6058-0300
Fax: +61 (2)6021-7403

ITALY

Apex Tool S.r.l.
Viale Europa 80
20090 Cusago (MI)

Tel: +39 (02)9033101
Fax: +39 (02)90394231

SWITZERLAND

Apex Tool Switzerland Sàrl
Crêt-St-Tombet 15
2022 Bevaix

Tel: +41 (0) 24 426 12 06
Fax: +41 (0) 24 425 09 77

INDIA

Apex Tool Group India Pvt. Ltd.
Regus business centre
Level 2, Elegance, Room no. 214
Mathura Road, Jasola
New Dehli - 110025

FRANCE

Apex Tool Group SNC
25 Avenue Maurice Chevalier
77832 Ozoir-la-Ferrière

Tel: +33 (0)1.64.43.22.00
Fax: +33 (0)1.64.43.21.62

USA

Apex Tool Group, LLC
14600 York Rd. Suite A
Sparks, MD 21152

Tel: +1 (800)688-8949
Fax: +1 (800)234-0472

CHINA

Apex Tool Group
A-8 building
No. 38 Dongsheng Road
Heqing Industrial Park, Pudong
Shanghai 201201

Tel: +86 (21)60880288
Fax: +86 (21)60880289

GREAT BRITAIN

Apex Tool Group (UK Operations) Ltd
4th Floor Pennine House
Washington, Tyne & Wear
NE37 1LY

Tel: +44 (0) 191 419 7700
Fax: +44 (0) 191 417 9421

CANADA

Apex Tools – Canada
5925 McLaughlin Rd.
Mississauga, Ontario L5R 1B8

Tel. +1 (905) 501-4785
Fax. +1 (905) 387-2640

SOUTH EAST ASIA

Apex Power Tools India Pvt. Ltd.
Gala No. 1, Plot No. 5
S. No. 234, 235 & 245
India land Global Industrial Park
(Next to Tata Johnson Control)
Taluka-Mulsi, Phase-I
Hinjawadi Pune (411057)
Maharashtra, India
toolsindia@apextoolgroup.com

X-ON Electronics

Largest Supplier of Electrical and Electronic Components

Click to view similar products for [Soldering & Desoldering Stations](#) category:

Click to view products by [Apex Tool Group](#) manufacturer:

Other Similar products are found below :

[GS1116](#) [T0053650699](#) [BH-010](#) [T0058768747](#) [CA0202](#) [CA0201](#) [WXD2N](#) [T0058757898](#) [T0058768743N](#) [T0051512199N](#) [145-2000-ESDN](#)
[T0058758721N](#) [WTL1000-1](#) [WXD2020N](#) [TS2300D](#) [WELPB102](#) [0019208](#) [0780550](#) [CVC-9CH0025S](#) [CVC-8CH0010S](#) [CV-H5-DSHP](#)
[CL2466](#) [SL916-NI](#) [0016344](#) [00B.SA.0](#) [0120CDK](#) [0352830](#) [0551903](#) [0965970](#) [0DIG20A45](#) [0IC1100A](#) [0ICV2000XV](#) [0.SA.0](#) [0T56](#) [CL-](#)
[SFE/1 FILTERS](#) [PX0410/03P/5055](#) [RA150](#) [35464](#) [10G.SA.0](#) [10LL4](#) [3.TA](#) [AT850D/P](#) [TMT-HA300](#) [TMT-PH200](#) [TMT-PH300](#) [5-048](#) [5-](#)
[050](#) [5-051](#) [5-052](#) [5-054](#)