



Unparalleled: This planetary gearbox maintains its maximum efficiency even at the highest speeds

PE Planetary Gearheads are notably light and extremely powerful, yet suitable for complex production cycles due to a low friction bearing design and optimized lubrication. A genuine powerhouse at an attractive price.

1 Light, but powerful

The **PE** excels with its above-average weight to torque ratio, and it is 25% lighter than comparable conventional drives. You accordingly benefit from the highest dynamics needed for multiple axis systems.

2 Efficient and reliable

High performance at a fair price: This principle also applies to our **PE** planetary gearbox. It is powerful, yet efficient, and delivers a high performance for attractive acquisition costs.

3 Low heat generation at the highest speeds

Even in extreme situations, the **PE** will never let you down thanks to its low-friction bearing design and optimized lubrication. The low heat generation allows a continuous high speed without sacrifice to performance.

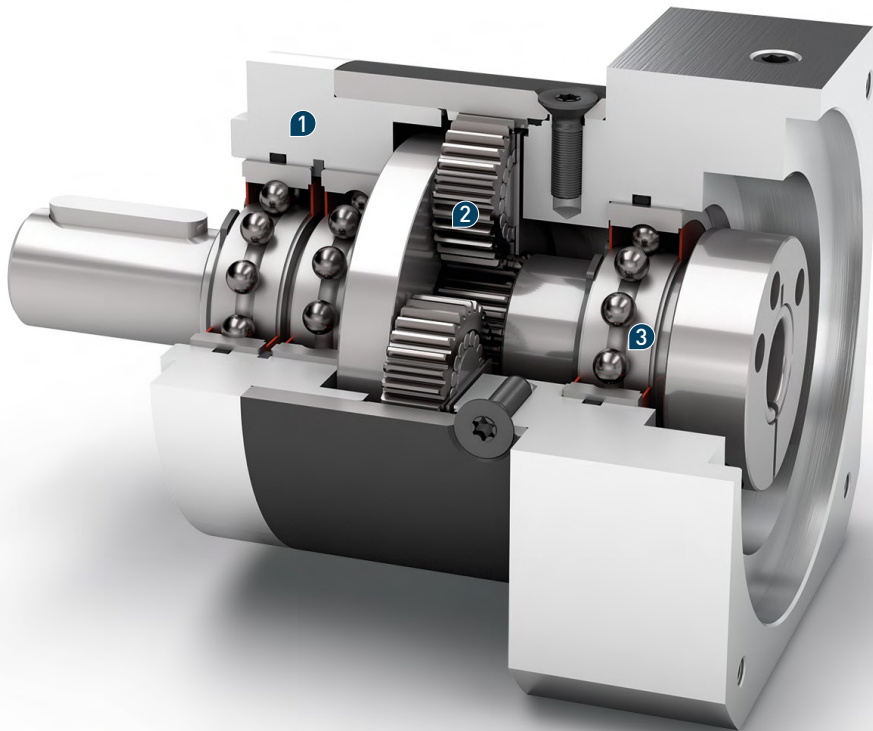

- + For any mounting position
- + Individual adaptation of the input flange to the motor
- + Lifetime lubrication for maintenance-free operation
- + Equidirectional rotation
- + Wide range of output shaft designs
- + Clamping systems with optimized mass moment of inertia
- + Precise gearing

Code	Gearbox characteristics			40PE	60PE	80PE	120PE*	160PE*	z ⁽¹⁾
	Service life	t _L	h	30,000					
	Efficiency at full load ⁽²⁾	η	%	98					1
97					2				
92					3				
	Min. operating temperature	T _{min}	°C	-25 (-13)					
	Max. operating temperature	T _{max}	(°F)	90 (194)					
	Protection class			IP 54					
S	Standard lubrication			Grease					
F	Food grade lubrication			Grease					
L	Low temperature lubrication ⁽³⁾			Grease					
	Installation position			Any					
S	Standard backlash	j _t	arcmin	< 15	< 10	< 7	< 7	< 6	1
				< 19	< 12	< 9	< 9	< 10	2
				< 22	< 15	< 11	< 11	-	3
	Torsional stiffness ⁽²⁾	c _g	Nm/arcmin (lb _r .in/ arcmin)	0.7 - 1.0 (6 - 9)	1.7 - 2.3 (15 - 20)	4.3 - 5.8 (38 - 51)	10.8 - 14.5 (96 - 128)	31.0 - 37.5 (274 - 332)	1
				0.8 - 1.0 (7 - 9)	1.9 - 2.3 (17 - 20)	4.7 - 5.8 (42 - 51)	11.7 - 14.5 (104 - 128)	30.5 - 37.5 (270 - 332)	2
				0.8 - 1.0 (7 - 9)	1.8 - 2.3 (16 - 20)	4.5 - 5.8 (40 - 51)	11.2 - 14.5 (99 - 128)	-	3
	Gearbox weight	m _G	kg (lb _m)	0.35 (0.8)	0.9 (2.0)	2.1 (4.6)	6 (13.2)	18 (39.7)	1
				0.45 (1.0)	1.1 (2.4)	2.6 (5.7)	8 (17.6)	22 (48.5)	2
				0.55 (1.2)	1.3 (2.9)	3.1 (6.8)	10 (22.1)	-	3
S	Standard surface			Housing: Steel – nitrocarburized and post-oxidized (black)					
	Running noise ⁽⁴⁾	Q _g	dB(A)	58	58	60	65	70	
	Max. bending moment based on the gearbox input flange ⁽⁵⁾	M _b	Nm (lb _r .in)	3 (27)	8 (71)	16 (142)	40 (354)	140 (1239)	
	Motor flange precision			DIN 42955-N					

Output shaft loads				40PE	60PE	80PE	120PE*	160PE*	z ⁽¹⁾
	Radial force for 20,000h ⁽⁶⁾⁽⁷⁾	F _{r 20.000 h}	N (lb _r)	200 (45)	400 (90)	750 (169)	1750 (394)	5000 (1125)	
	Axial force for 20,000h ⁽⁶⁾⁽⁷⁾	F _{a 20.000 h}		200 (45)	500 (113)	1000 (225)	2500 (563)	7000 (1575)	
	Radial force for 30,000h ⁽⁶⁾⁽⁷⁾	F _{r 30.000 h}		160 (36)	340 (77)	650 (146)	1500 (338)	4200 (945)	
	Axial force for 30,000h ⁽⁶⁾⁽⁷⁾	F _{a 30.000 h}		160 (36)	450 (101)	900 (203)	2100 (473)	6000 (1350)	
	Static radial force ⁽⁷⁾⁽⁸⁾	F _{r Stat}		200 (45)	700 (158)	1250 (281)	2000 (450)	5000 (1125)	
	Static axial force ⁽⁷⁾⁽⁸⁾	F _{a Stat}		240 (54)	800 (180)	1600 (360)	3800 (855)	11000 (2475)	
	Tilting moment for 20,000 h ⁽⁶⁾⁽⁸⁾	M _{K 20.000 h}	Nm (lb _r .in)	5 (44)	14 (124)	31 (274)	101 (894)	474 (4195)	
	Tilting moment for 30,000 h ⁽⁶⁾⁽⁸⁾	M _{K 30.000 h}		4 (35)	12 (106)	27 (239)	86 (761)	398 (3522)	

Moment of inertia				40PE	60PE	80PE	120PE*	160PE*	z ⁽¹⁾
	Mass moment of inertia ⁽²⁾	J	kgcm ² (lb _r .in.s ² 10 ⁻⁴)	0.014 - 0.027 (0.124 - 0.239)	0.065 - 0.128 (0.575 - 1.133)	0.359 - 0.654 (3.177 - 5.788)	1.378 - 2.361 (12.195 - 20.895)	3.726 - 11.999 (32.975 - 106.191)	1
				0.015 - 0.026 (0.133 - 0.230)	0.066 - 0.121 (0.584 - 1.071)	0.365 - 0.613 (3.230 - 5.425)	1.414 - 2.288 (12.514 - 20.249)	3.502 - 10.087 (30.993 - 89.270)	2
				0.015 - 0.025 (0.133 - 0.221)	0.066 - 0.076 (0.584 - 0.673)	0.365 - 0.590 (3.230 - 5.222)	1.413 - 2.196 (12.505 - 19.435)	-	3

*Contact Applied Motion Products for Price and Availability of 120 and 160 mm Gearboxes.

(1) Number of stages

(2) Contact Applied Motion Products for ratio-dependent values.

(3) T_{min} = -40°C (-40°F). Optimal operating temperature max. 50°C (122°F)

(4) Sound pressure level from 1m, measured on input running at n₁=3000 rpm no load; i=5

(5) Max. motor weight* in kg = 0.2 x M_G / motor length in m

* with symmetrically distributed motor weight

* with horizontal and stationary mounting

(6) These values are based on an output shaft speed of n₂=100 rpm

(7) Based on center of output shaft

(8) Other (sometimes higher) values following changes to T_{2N1}, F_r, F_a, cycle, and service life of bearing. Application specific configuration with NCP

Output torques			40PE	60PE	80PE	120PE*	160PE*	i ⁽¹⁾	z ⁽²⁾
Nominal output torque ⁽³⁾⁽⁴⁾	T _{2N}	Nm (lb _r .in)	11 (97)	28 (248)	85 (752)	115 (1018)	400 (3540)	3	1
			15 (133)	38 (336)	115 (1018)	155 (1372)	450 (3983)	4	
			14 (124)	40 (354)	110 (974)	195 (1726)	450 (3983)	5	
			8.5 (75)	25 (221)	65 (575)	135 (1195)	-	7	
			6 (53)	18 (159)	50 (443)	120 (1062)	450 (3983)	8	
			5 (44)	15 (133)	38 (336)	95 (841)	-	10	
			16.5 (146)	44 (389)	130 (1151)	210 (1859)	-	9	2
			20 (177)	44 (389)	120 (1062)	260 (2301)	800 (7080)	12	
			18 (159)	44 (389)	110 (974)	230 (2036)	700 (6195)	15	
			20 (177)	44 (389)	120 (1062)	260 (2301)	800 (7080)	16	
			20 (177)	44 (389)	120 (1062)	260 (2301)	800 (7080)	20	
			18 (159)	40 (354)	110 (974)	230 (2036)	700 (6195)	25	
			20 (177)	44 (389)	120 (1062)	260 (2301)	800 (7080)	32	
			18 (159)	40 (354)	110 (974)	230 (2036)	700 (6195)	40	
			7.5 (66)	18 (159)	50 (443)	120 (1062)	450 (3983)	64	
			20 (177)	44 (389)	110 (974)	260 (2301)	-	60	
			20 (177)	44 (389)	120 (1062)	260 (2301)	-	80	
			20 (177)	44 (389)	120 (1062)	260 (2301)	-	100	
			18 (159)	44 (389)	110 (974)	230 (2036)	-	120	
			20 (177)	44 (389)	120 (1062)	260 (2301)	-	160	
			18 (159)	40 (354)	110 (974)	230 (2036)	-	200	
			20 (177)	44 (389)	120 (1062)	260 (2301)	-	256	
			18 (159)	40 (354)	110 (974)	230 (2036)	-	320	
			7.5 (66)	18 (159)	50 (443)	120 (1062)	-	512	
Max. output torque ⁽⁴⁾⁽⁵⁾	T _{2max}	Nm (lb _r .in)	17.5 (155)	45 (398)	136 (1204)	184 (1628)	640 (5664)	3	1
			24 (212)	61 (540)	184 (1628)	248 (2195)	720 (6372)	4	
			22 (195)	64 (566)	176 (1558)	312 (2761)	720 (6372)	5	
			13.5 (119)	40 (354)	104 (920)	216 (1912)	-	7	
			10 (89)	29 (257)	80 (708)	192 (1699)	720 (6372)	8	
			8 (71)	24 (212)	61 (540)	152 (1345)	-	10	
			26 (230)	70 (620)	208 (1841)	336 (2974)	-	9	2
			32 (283)	70 (620)	192 (1699)	416 (3682)	1280 (11328)	12	
			29 (257)	70 (620)	176 (1558)	368 (3257)	1120 (9912)	15	
			32 (283)	70 (620)	192 (1699)	416 (3682)	1280 (11328)	16	
			32 (283)	70 (620)	192 (1699)	416 (3682)	1280 (11328)	20	
			29 (257)	64 (566)	176 (1558)	368 (3257)	1120 (9912)	25	
			32 (283)	70 (620)	192 (1699)	416 (3682)	1280 (11328)	32	
			29 (257)	64 (566)	176 (1558)	368 (3257)	1120 (9912)	40	
			12 (106)	29 (257)	80 (708)	192 (1699)	720 (6372)	64	
			32 (283)	70 (620)	176 (1558)	416 (3682)	-	60	
			32 (283)	70 (620)	192 (1699)	416 (3682)	-	80	
			32 (283)	70 (620)	192 (1699)	416 (3682)	-	100	
			29 (257)	70 (620)	176 (1558)	368 (3257)	-	120	
			32 (283)	70 (620)	192 (1699)	416 (3682)	-	160	
			29 (257)	64 (566)	176 (1558)	368 (3257)	-	200	
			32 (283)	70 (620)	192 (1699)	416 (3682)	-	256	
			29 (257)	64 (566)	176 (1558)	368 (3257)	-	320	
			12 (106)	29 (257)	80 (708)	192 (1699)	-	512	

*Contact Applied Motion Products for Price and Availability of 120 and 160 mm Gearboxes.

⁽¹⁾ Ratios (i=n₁/n₂)

⁽²⁾ Number of stages

⁽³⁾ Application specific configuration with NCP

⁽⁴⁾ Values for feather key (code "A"): for repeated load

⁽⁵⁾ 30,000 rotations of the output shaft permitted; see page 128

Output torques			40PE	60PE	80PE	120PE*	160PE*	i ⁽¹⁾	z ⁽²⁾
Emergency stop torque ⁽³⁾	T _{2Stop}	Nm (lb _r .in)	22,5 (199)	66 (584)	180 (1593)	390 (3452)	800 (7080)	3	1
			30 (266)	88 (779)	240 (2124)	520 (4602)	900 (7965)	4	
			36 (319)	80 (708)	220 (1947)	500 (4425)	900 (7965)	5	
			26 (230)	80 (708)	178 (1575)	340 (3009)	-	7	
			27 (239)	80 (708)	190 (1682)	380 (3363)	900 (7965)	8	
			27 (239)	80 (708)	200 (1770)	480 (4248)	-	10	
			33 (292)	88 (779)	260 (2301)	500 (4425)	-	9	
			40 (354)	88 (779)	240 (2124)	520 (4602)	1600 (14160)	12	
			36 (319)	88 (779)	220 (1947)	500 (4425)	1400 (12390)	15	
			40 (354)	88 (779)	240 (2124)	520 (4602)	1600 (14160)	16	
			40 (354)	88 (779)	240 (2124)	520 (4602)	1600 (14160)	20	
			36 (319)	80 (708)	220 (1947)	500 (4425)	1400 (12390)	25	
		40 (354)	88 (779)	240 (2124)	520 (4602)	1600 (14160)	32		
		36 (319)	80 (708)	220 (1947)	500 (4425)	1400 (12390)	40		
		27 (239)	80 (708)	190 (1682)	380 (3363)	900 (7965)	64		
		40 (354)	88 (779)	220 (1947)	520 (4602)	-	60		
		40 (354)	88 (779)	240 (2124)	520 (4602)	-	80		
		40 (354)	88 (779)	240 (2124)	520 (4602)	-	100		
		36 (319)	88 (779)	220 (1947)	500 (4425)	-	120		
		40 (354)	88 (779)	240 (2124)	520 (4602)	-	160		
		36 (319)	80 (708)	220 (1947)	500 (4425)	-	200		
		40 (354)	88 (779)	240 (2124)	520 (4602)	-	256		
		36 (319)	80 (708)	220 (1947)	500 (4425)	-	320		
		27 (239)	80 (708)	190 (1682)	380 (3363)	-	512		

Input speeds			40PE	60PE	80PE	120PE*	160PE*	i ⁽¹⁾	z ⁽²⁾
Average thermal input speed at T _{2N} and S1 ⁽⁴⁾⁽⁵⁾	n _{1N}	rpm	5000	4500	4000 ⁽⁶⁾	3400 ⁽⁶⁾	1350 ⁽⁶⁾	3	1
			5000	4500	3900 ⁽⁶⁾	3500 ⁽⁶⁾	1450 ⁽⁶⁾	4	
			5000	4500	4000 ⁽⁶⁾	3500 ⁽⁶⁾	1700 ⁽⁶⁾	5	
			5000	4500	4000	3500	-	7	
			5000	4500	4000	3500	2200 ⁽⁶⁾	8	
			5000	4500	4000	3500	-	10	
			5000	4500	4000 ⁽⁶⁾	3500 ⁽⁶⁾	-	9	
			5000	4500	4000 ⁽⁶⁾	3500 ⁽⁶⁾	1600 ⁽⁶⁾	12	
			5000	4500	4000	3500 ⁽⁶⁾	1900 ⁽⁶⁾	15	
			5000	4500	4000	3500 ⁽⁶⁾	1800 ⁽⁶⁾	16	
			5000	4500	4000	3500	2100 ⁽⁶⁾	20	
			5000	4500	4000	3500	2400 ⁽⁶⁾	25	
		5000	4500	4000	3500	2700 ⁽⁶⁾	32		
		5000	4500	4000	3500	3000 ⁽⁶⁾	40		
		5000	4500	4000	3500	3000	64		
		5000	4500	4000	3500	-	60		
		5000	4500	4000	3500	-	80		
		5000	4500	4000	3500	-	100		
		5000	4500	4000	3500	-	120		
		5000	4500	4000	3500	-	160		
		5000	4500	4000	3500	-	200		
		5000	4500	4000	3500	-	256		
		5000	4500	4000	3500	-	320		
		5000	4500	4000	3500	-	512		
Max. mechanical input speed ⁽⁴⁾	n _{1Limit}	rpm	18000	13000	7000	6500	6500		

*Contact Applied Motion Products for Price and Availability of 120 and 160 mm Gearboxes.

⁽¹⁾ Ratios (i=n₁/n₂)

⁽²⁾ Number of stages

⁽³⁾ Permitted 1000 times

⁽⁴⁾ Application-specific speed configurations with NCP

⁽⁵⁾ See page 128 for the definition

⁽⁶⁾ Average thermal input speed at 50% T_{2N} and S1

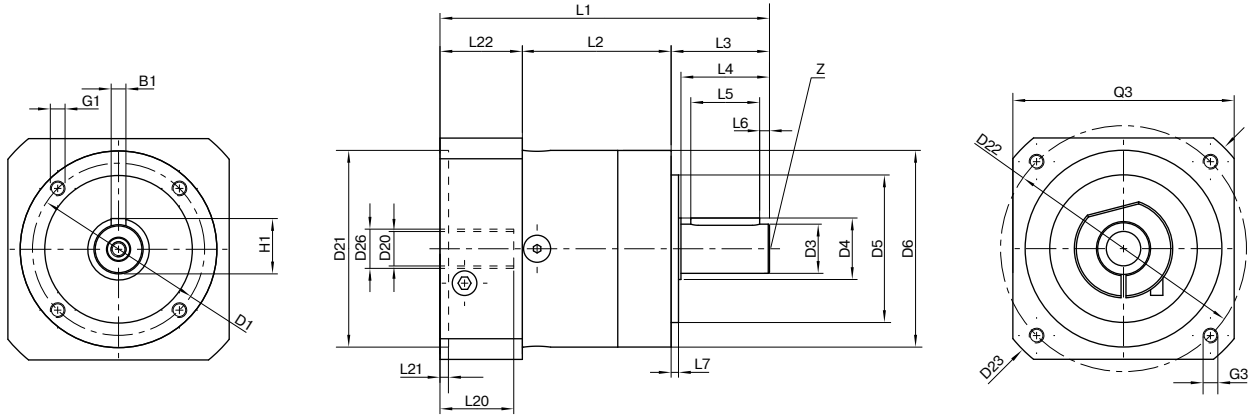

Drawing corresponds to a 60PE / 1-stage / output shaft with feather key / 11 mm clamping system / motor adaptation – one part / B5 flange type motor

Geometry ⁽¹⁾			40PE	60PE	80PE	120PE*	160PE*	z ⁽²⁾	Code
Pitch circle diameter output	D1		34 (1.339)	52 (2.047)	70 (2.756)	100 (3.937)	145 (5.709)		
Shaft diameter output	D3	h7	10 (0.394)	14 (0.551)	20 (0.787)	25 (0.984)	40 (1.575)		
Shaft collar output	D4		12 (0.472)	17 (0.669)	25 (0.984)	35 (1.378)	55 (2.165)		
Centering diameter output	D5	h7	26 (1.024)	40 (1.575)	60 (2.362)	80 (3.150)	130 (5.118)		
Housing diameter	D6		40 (1.575)	60 (2.362)	80 (3.150)	115 (4.528)	160 (6.299)		
Mounting thread x depth	G1	4x	M4x6	M5x8	M6x10	M10x16	M12x20		
Min. total length	L1		88.5 (3.484)	106 (4.173)	133.5 (5.256)	176.5 (6.949)	255.5 (10.059)	1	
			101.5 (3.996)	118.5 (4.665)	150.5 (5.925)	204 (8.031)	305 (12.008)	2	
			114 (4.488)	131 (5.157)	168 (6.614)	231.5 (9.114)	-	3	
Housing length	L2		39 (1.535)	47 (1.850)	60 (2.362)	74 (2.913)	104 (4.094)	1	
			52 (2.047)	59.5 (2.343)	77.5 (3.051)	101.5 (3.996)	153.5 (6.043)	2	
			64.5 (2.539)	72 (2.835)	95 (3.740)	129 (5.079)	-	3	
Shaft length output	L3		26 (1.024)	35 (1.378)	40 (1.575)	55 (2.165)	87 (3.425)		
Centering depth output	L7		2 (0.079)	3 (0.118)	3 (0.118)	4 (0.157)	5 (0.197)		
Clamping system diameter input	D26		Motor dependent						
Motor shaft diameter j6/k6	D20		Motor dependent						
Max. permis. motor shaft length	L20		Motor dependent						
Min. permis. motor shaft length			Motor dependent						
Centering diameter input	D21		Motor dependent						
Centering depth input	L21		Motor dependent						
Pitch circle diameter input	D22		Motor dependent						
Motor flange length	L22		Motor dependent						
Diagonal dimension input	D23		Motor dependent						
Mounting thread x depth	G3	4x	Motor dependent						
Flange cross section input	Q3	■	Motor dependent						
Output shaft with feather key (DIN 6885-1)			A 3x3x18	A 5x5x25	A 6x6x28	A 8x7x40	A 12x8x65		A
Feather key width (DIN 6885-1)	B1		3 (0.118)	5 (0.197)	6 (0.236)	8 (0.315)	12 (0.472)		
Shaft height including feather key (DIN 6885-1)	H1		11.2 (0.441)	16 (0.630)	22.5 (0.886)	28 (1.102)	43 (1.693)		
Shaft length from shoulder	L4		23 (0.906)	30 (1.181)	36 (1.417)	50 (1.969)	80 (3.150)		
Feather key length	L5		18 (0.709)	25 (0.984)	28 (1.102)	40 (1.575)	65 (2.559)		
Distance from shaft end	L6		2.5 (0.098)	2.5 (0.098)	4 (0.157)	5 (0.197)	8 (0.315)		
Center hole (DIN 332, type DR)	Z		M3x9	M5x12.5	M6x16	M10x22	M16x36		
Smooth output shaft									B
Shaft length from shoulder	L4		23 (0.906)	30 (1.181)	36 (1.417)	50 (1.969)	80 (3.150)		

*Contact Applied Motion Products for Price and Availability of 120 and 160 mm Gearboxes.

⁽¹⁾ Dimensions in mm (in)

⁽²⁾ Number of stages

X-ON Electronics

Largest Supplier of Electrical and Electronic Components

Click to view similar products for [Motor Drives](#) category:

Click to view products by [Applied Motion](#) manufacturer:

Other Similar products are found below :

[GMA02](#) [R7DBP02L](#) [1300920283](#) [ST10-S](#) [GMA11](#) [GMA20](#) [R88DUA03LAAC100V30W](#) [R88DUA12HA](#) [R88DUP03LAAC100V30W](#)
[STR2](#) [VFD002EL11A](#) [MFMCB0030GET](#) [MFECA0030EAM](#) [1302263150](#) [1300920078](#) [R88D-GT04H](#) [R88D-GN04H-ML2](#) [R7D-BP01H](#)
[R88D-KN04L-ECT](#) [70354063](#) [79294435](#) [27358015](#) [15275008](#) [ST5-Q-EN](#) [1SFA896103R1100](#) [1SFA896103R7000](#) [1SFA896112R1100](#)
[R88D-GP08H](#) [GNCF8-11](#) [KLC35BE](#) [ST10-Q-RN](#) [1302263161](#) [SV2D10-Q-AE](#) [VX5A1300](#) [R88A-CA1C005SF-E](#) [R88A-CR1B005NF-E](#)
[SEH 71-4B](#) [LUCC12BL](#) [LUCC12FU](#) [LU9BN11L](#) [LULC08](#) [GV2P01](#) [UDS1UR6M50CANCZ183](#) [LC1D09M7](#) [103H7126-1740](#) [103H7823-1741](#) [111.3761.20.00E](#) [111.3761.30.00E](#) [808070RAT250](#) [FMJ7201FB1](#)