

SiNet™ Hub 444

Multi-Axis Motion Hub with I/O

Features

- Networks all Applied Motion Stepper or Servo *Si™* products for multi-axis motion applications
- For real time execution of commands downloaded from a host PC or PLC using Applied Motion's *Si Command Language™ (SCL)*
- Programmable for stand alone single or multi-axis operations with Applied Motion's easy to use *SiNet Hub Programmer™* Windows software (software and programming cable included)
- Communication via RS232
- Four optically isolated programmable inputs
- Four optically isolated programmable outputs
- Optional DIN rail mounting kit

Description

The SiNet™ Hub 444 allows up to 4 Stepper or Servo *Si™* drives to be controlled in host mode from a single PC or PLC's RS-232 serial port or will run in stand-alone mode.

Each indexer-drive acquires its unique address from the port to which it is connected. This simple addressing scheme minimizes the cost of the drives, and more importantly, the cost of configuring and/or replacing drives in your system. Connections are made with low cost, reliable telephone cabling.

Any of our popular, cost effective programmable Stepper or Servo *Si™* drives or *Si™* motor controls can be used with the SiNet™ Hub 444. By choosing the power level and features you need for each axis of your application, SiNet™ can provide a cost effective single or multi-axis motion solution.

The SiNet™ Hub 444 is powered by the drive that's connected to port #1, saving you the cost and installation expense of using a separate power supply. Our *Si™* Command Language (SCL) allows a host PC or PLC to execute relative, absolute and homing moves, make status inquiries, sample inputs, set outputs, and more.

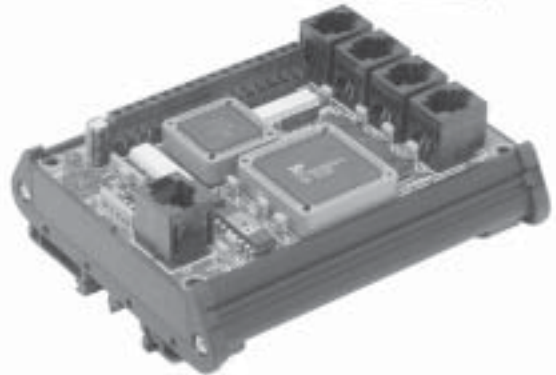
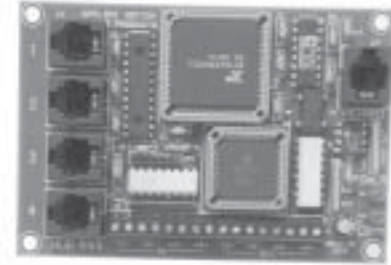

If your application requires a single axis to operate in "host mode", you can connect any of our programmable *Si™* drives directly to your PC via the SiNet Hub 444 and invoke the *Si™* Command Language (SCL).

Our SiNet Programmer™ Windows software allows the user to create and store multi-axis motion control programs in the SiNet™ Hub 444 and run them without a PC. Thus allowing the user to create a complex multi-axis motion system controlled from an operator interface or trigger.

Recommended Drives

<u>Stepper</u>	<u>Servo</u>	<u>Control</u>
Si3540	BLSi7080	Si-100
Si5580	BL7080i	
1240i		
3540i		
7080i		

SiNet Hub Technical Specifications

Power	Power is provided by Si™ indexer-drive on Port 1. Provides up to 50 mA for MMI via PC/MMI port.
Communication	Ports 1 - 4: RS232, 9600 bps, 8 data bits, one stop bit, no parity. MMI: same. PC in router mode: same. PC when running SiNet Programmer software: 19200 bps. Max cable length, any port: 50 feet.
Physical	Constructed on .062" fiberglass printed circuit board with 4 .156" mounting holes (nylon spacers included). 4.2" x 2.85" x 0.72". Two red LEDs. Operating temperature range: 0 - 70° C. Optional DIN rail mounting kit (fits ENS0022 35 mm rail).
Program.	Move distances: +/- 16,000,000 steps Move speeds: .025 to 50 rev/sec Accel/Decel range: 1 to 3000 rev/sec/sec Time delays: .01 to 300 seconds Loop counts: 1 to 65,535 Number of nested loops: unlimited Number of subroutines: unlimited Subroutine stack depth: 5 calls maximum Number of comments: limited only by 200 line program length MMI variables for storing speeds, distances and loop counts entered by operator: 50 Maximum size of messages displayed by an MMI Prompt: 60 characters (80 for an MMI Menu instruction) Maximum total size of all MMI Prompt messages: 1500 characters Steps/revolution: 2,000 - 50,800 (200 - 50,800 with Si-100 indexer)
Connectors	RJ11 for drives and PC/MMI. Screw terminals for programmable inputs and outputs. Accept AWG 16-28 wire.
Programmable Inputs	Optically isolated, 2200 ohms internal impedance, 5–24 VDC.
Programmable Outputs	Optically isolated (photo darlington), 28 VDC max, 100 mA max.

SiNet Hub 444 Technical Drawings

MECHANICAL OUTLINE:

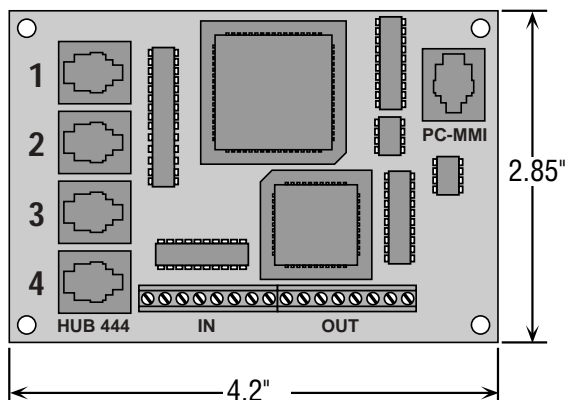

BLOCK DIAGRAM:

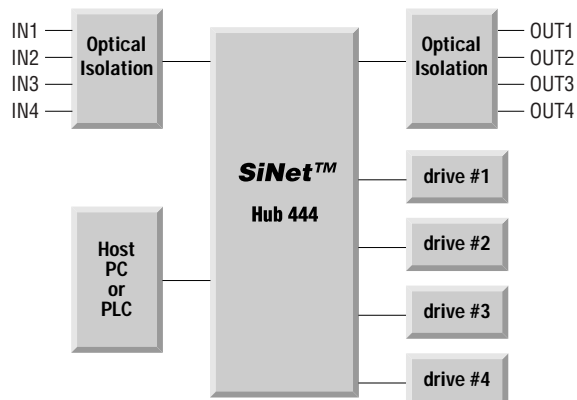

X-ON Electronics

Largest Supplier of Electrical and Electronic Components

Click to view similar products for [Motor Drives](#) category:

Click to view products by [Applied Motion](#) manufacturer:

Other Similar products are found below :

[GMA02](#) [R7DBP02L](#) [1300920283](#) [ST10-S](#) [GMA11](#) [GMA20](#) [R88DUA03LAAC100V30W](#) [R88DUA12HA](#) [R88DUP03LAAC100V30W](#)
[STR2](#) [VX5A1400](#) [VFD002EL11A](#) [MFMCB0030GET](#) [MFECA0030EAM](#) [1302263150](#) [1300920078](#) [R88D-GT04H](#) [R88D-GN04H-ML2](#)
[R7D-BP01H](#) [R88D-KN04L-ECT](#) [70354063](#) [79294435](#) [27358015](#) [15275008](#) [ST5-Q-EN](#) [1SFA896103R1100](#) [1SFA896103R7000](#)
[1SFA896112R1100](#) [R88D-GP08H](#) [GNCF8-11](#) [KLC35BE](#) [ST10-Q-RN](#) [1302263161](#) [SV2D10-Q-AE](#) [VX5A1300](#) [R88A-CA1C005SF-E](#)
[R88A-CR1B005NF-E](#) [SEH 71-4B](#) [U-PKZ0\(400V50HZ\)](#) [LUCC12BL](#) [LUCC12FU](#) [LU9BN11L](#) [LULC08](#) [GV2P01](#)
[UDS1UR6M50CANCZ183](#) [LC1D09M7](#) [103H7126-1740](#) [103H7823-1741](#) [111.3761.20.00E](#) [111.3761.30.00E](#)