

Description

The SLVU2.8-4 is designed to protect low voltage, CMOS semiconductors from transients caused by electrostatic discharge (ESD), cable discharge events (CDE), lightning and other induced voltage surges. Low capacitance compensation diode is integrated into the TVS to lower the typical capacitance to 1pf per line. The SLVU2.8-4 complies with the IEC 61000-4-2 (ESD) standard with $\pm 15\text{kV}$ air and $\pm 8\text{kV}$ contact discharge. The SLVU2.8-4 is assembled into a 8-pin lead-free SO-8 package, The combination of low leakage, signal integrity and flow through design makes the SLVU2.8-4 an ideal application such as 10/100/1000 Ethernet.

Features

- 600W peak pulse power (8/20 μs)
- Protects two line pairs (four lines)
- Ultra low leakage: nA level
- Low operating voltage: 2.8V
- Very low capacitance: 2pF
- Ultra low clamping voltage
- JEDEC SO-8 package
- Complies with following standards:
 - IEC 61000-4-2 (ESD) immunity test
 - Air discharge: $\pm 30\text{kV}$
 - Contact discharge: $\pm 30\text{kV}$
 - IEC61000-4-5 (Lightning) 30A (8/20 μs)
- RoHS Compliant

Mechanical Characteristics

- Package: SO-8
- Lead Finish: Matte Tin
- Moisture Sensitivity: Level 3 per J-STD-020
- Terminal Connections: See Diagram Below
- Marking Information: See Below

Applications

- Base Station
- Analog Inputs
- Switch Systems
- 10/100/1000 Ethernet
- WAN/LAN Equipment
- Desktops, Servers, and Notebooks
- Low Voltage Interfaces

Marking Information

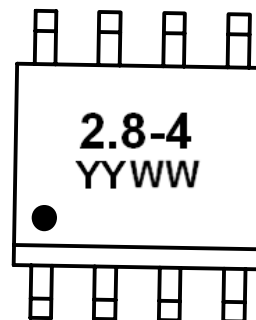

2.8-4= Device Marking Code
 YYWW = Date Code
 Dot denotes Pin1

Dimensions and Pin Configuration

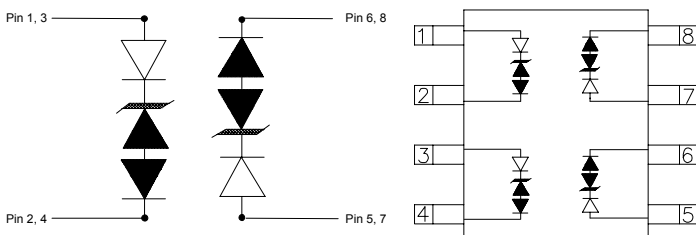

Circuit and Pin Schematic

SO-8 Outline

Ordering Information

Part Number	Packaging	Reel Size
SLVU2.8-4	2500/Tape & Reel	13 inch

Absolute Maximum Ratings ($T_A=25^\circ\text{C}$ unless otherwise specified)

Parameter	Symbol	Value	Unit
Peak Pulse Power (8/20 μs)	Ppk	600	W
Peak Pulse Current (8/20 μs)	I _{PP}	30	A
ESD per IEC 61000-4-2 (Air)	V _{ESD}	± 30	kV
ESD per IEC 61000-4-2 (Contact)		± 30	
Operating Temperature Range	T _J	-55 to +125	$^\circ\text{C}$
Storage Temperature Range	T _{stg}	-55 to +150	$^\circ\text{C}$

Electrical Characteristics ($T_A=25^\circ\text{C}$ unless otherwise specified)

Parameter	Symbol	Min	Typ	Max	Unit	Test Condition
Reverse Working Voltage	V _{RWM}			2.8	V	
Breakdown Voltage	V _{BR}	3.0			V	I _T = 2 μA
	V _{SB}	3.0			V	I _{SB} = 50mA
Reverse Leakage Current	I _R		0.001	1	μA	V _{RWM} = 2.8V
Clamping Voltage	V _C			8.5	V	I _{PP} = 5A (8 x 20 μs pulse)
Clamping Voltage	V _C			18	V	I _{PP} = 25A (8 x 20 μs pulse)
Clamping Voltage	V _C			20	V	I _{PP} = 30A (8 x 20 μs pulse)
Junction Capacitance	C _J		2	3	pF	V _R = 0V, f = 1MHz

Typical Performance Characteristics ($T_A=25^{\circ}\text{C}$ unless otherwise Specified)

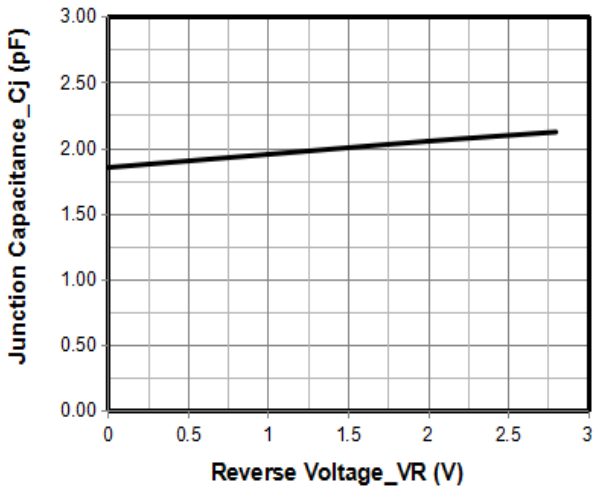

Junction Capacitance vs. Reverse Voltage

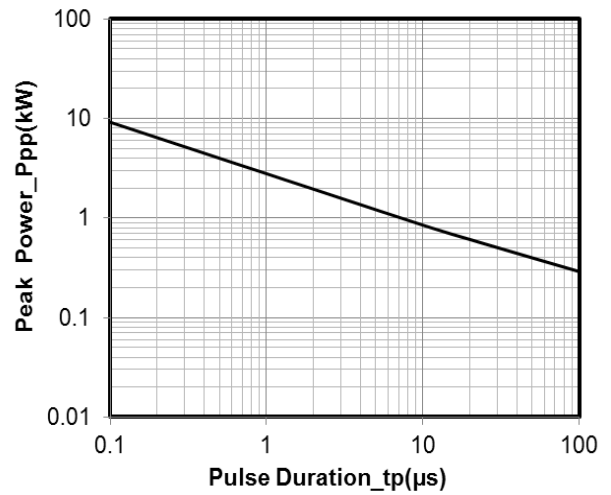

Peak Pulse Power vs. Pulse Time

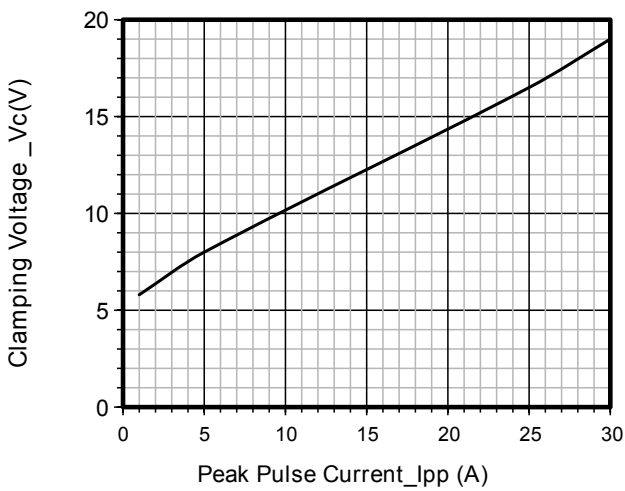

Clamping Voltage vs. Peak Pulse Current

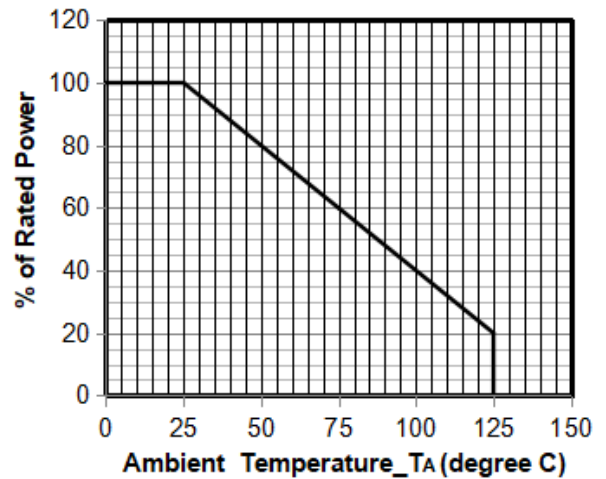

Power Derating Curve

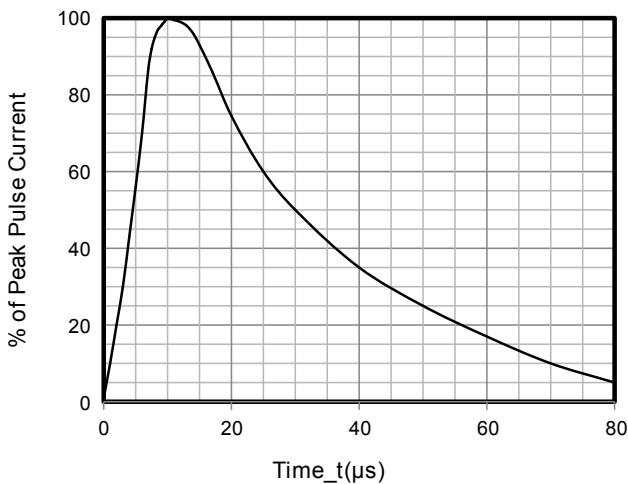

8 X 20μs Pulse Waveform

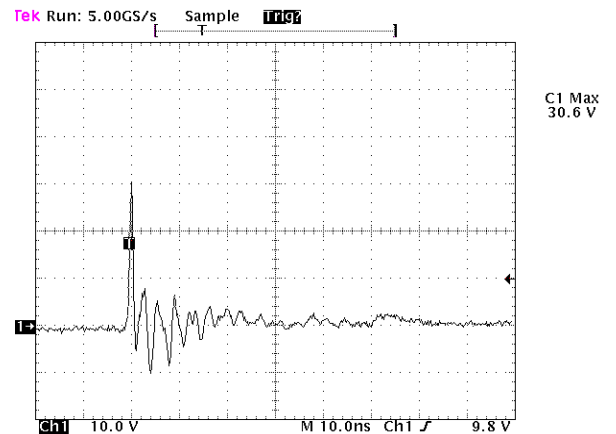

Note: Data is taken with a 10x attenuator

ESD Clamping Voltage
8 kV Contact per IEC61000-4-2

Typical Application

The SLVU2.8-4 is designed such that the data lines are routed through the device. The first line pair enters at pins 1 and 2 and exit at pins 8 and 7 respectively. The second line pair enters at pins 3 and 4 and exits at pins 6 and 5. The traces must be connected at the bottom of the device as shown.

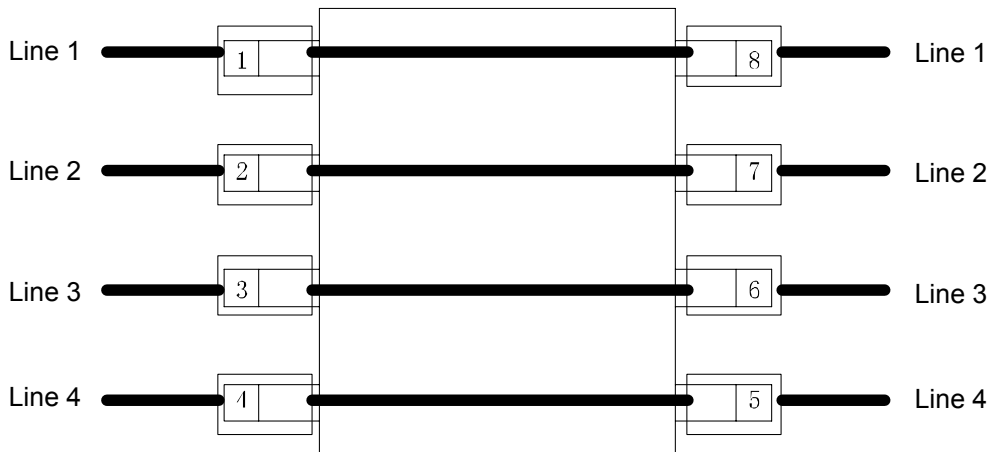

Low capacitance protection of two differential line pairs

SLVU2.8-4 on Ethernet Application

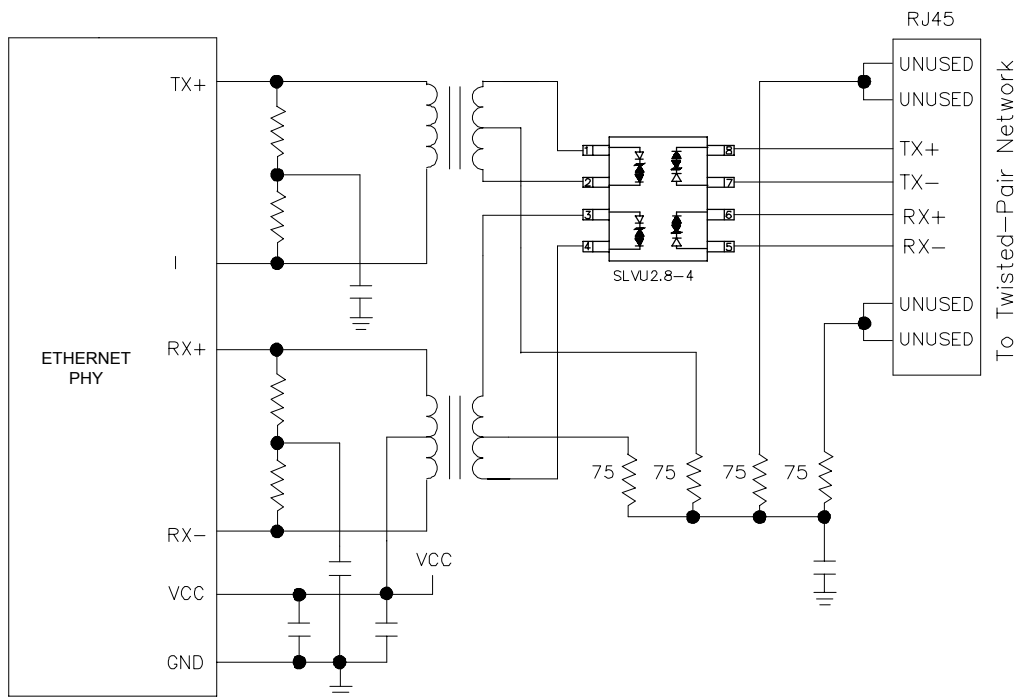

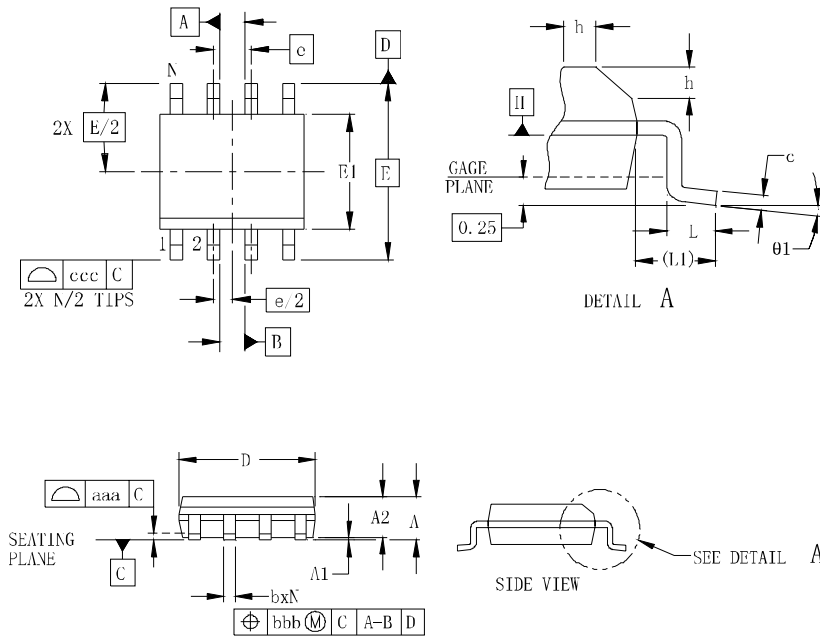
SO-8 Package Outline Drawing

SYM	DIMENSIONS					
	MILLIMETERS			INCHES		
	MIN	NOM	MAX	MIN	NOM	MAX
A	1.35		1.75	0.053		0.069
A1	0.10		0.25	0.004		0.010
A2	1.25		1.65	0.049		0.065
b	0.31		0.51	0.012		0.020
c	0.17		0.25	0.007		0.010
D	4.80	4.90	5.00	0.189	0.193	0.197
E1	3.80	3.90	4.00	0.150	0.154	0.157
E	6.00 BSC			0.236 BSC		
e	1.27 BSC			0.050 BSC		
h	0.25		0.50	0.010		0.020
L	0.40	0.72	1.04	0.016	0.028	0.041
L1	(1.04)			(0.041)		
N	8			8		
θ1	0°		8°	0°		8°
aaa	0.10			0.004		
bbb	0.25			0.010		
ccc	0.20			0.008		

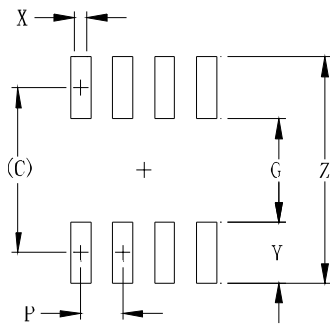
Suggested Land Pattern

SYM	DIMENSIONS	
	MILLIMETERS	INCHES
C	(5.20)	0.205
G	3.00	0.118
P	1.27	0.050
X	0.60	0.024
Y	2.20	0.087
Z	7.40	0.291

Contact Information

Applied Power Microelectronics Co., Ltd.
 Website: <http://www.appliedpowermicro.com>
 Email: sales@appliedpowermicro.com
 Phone: +86 (0519) 8399 3606

X-ON Electronics

Largest Supplier of Electrical and Electronic Components

Click to view similar products for [ESD Suppressors / TVS Diodes](#) category:

Click to view products by [Applied Power](#) manufacturer:

Other Similar products are found below :

[NTE4902](#) [P4SMAJ15A](#) [P4SMAJ26A](#) [SMAJ400CA-TP](#) [TGL34-47CA](#) [ESDAULC45-1BF4](#) [SM1605E3/TR13](#) [SMF20A-TP](#) [P4SMAJ12A](#)
[CPDUR24V-HF](#) [CPDQC5V0USP-HF](#) [CPDQC5V0-HF](#) [MPLAD30KP280A](#) [MPLAD30KP45CAE3](#) [MMBZ27VCLQ-7-F](#) [MMAD1108/TR13](#)
[MPLAD30KP24A](#) [MPLAD30KP30CAE3](#) [ACPDQC5V0R-HF](#) [DFLT170A-7](#) [NTE4900](#) [NTE4926](#) [NTE4938](#) [JANTX1N6144A](#)
[JANTX1N6057A](#) [SMF22A-TP](#) [SMF12A-TP](#) [SLVU2.8-TP](#) [SMLJ6.5CA-TP](#) [SMAJ6.5CA-TP](#) [MMAD1108E3/TR13](#) [JANTX1N6160A](#)
[D5V0M1U2LP3-7](#) [SMAJ400A-TP](#) [AOZ8811DT-03](#) [AOZ8831DI-05](#) [AOZ8831DT-03](#) [SMAJ188CA](#) [3SMC33CA BK](#) [CPDQC3V3C-HF](#)
[CPDQC12VE-HF](#) [GRPADATAJANTX1N6041A](#) [MPLAD30KP170CA](#) [82357120100](#) [5.0SMLJ15CA-TP](#) [5KP18A-TP](#) [P6KE8.2A-TP](#)
[MPLAD30KP43CAE3](#) [SMAJ43A-TP](#) [D26V0H1U2LP16-7](#)