

SYMBOL DEFINITION		MISSING SYMBOLS	
A DIMENSION WITHOUT AN INSPECTION REPORT SYMBOL DOES NOT REQUIRE INSPECTION. IT MAY BE CONTROLLED ON THE INDIVIDUAL COMPONENT DRAWING.	TOTAL NO OF INSPECTIONS REQUIRED	NO MISSING SYMBOL NUMBER	
	LAST NO. USED		
	20		
	18		

DWS STATUS		REVISION HISTORY		AUTH		DR		APVD		
DATE	STG	REV	N/P	CHG	ZONE					
30JUL02	R	05	-	-		CLEARED REV COLUMN & ALL PARTS - UPDATED PDM ATTRIBUTES	226419	EVV	EVV	TTP
06JUN03	R	06	-	-		15454820 - WAS ON SHT 3	240417	MRF	JOS	MPL
09JUN03	R	07	-	-		"SHEET 1 OF 5" WAS "SHEET 1 OF 4"	241567	AMG	AMG	RF
01AUG03	R	08	-	-		15454820 - UPDATED PDM ATTRIBUTES	242893	ADK	ADK	MPL
13FEB04	R	09	-	-		15454820 - UPDATED PDM ATTRIBUTES	251748	ADK	ADK	MPL
16AUG04	R	10	-	-		ADDED TERMINAL I.D. NOTE; REMOVED "PXX" FROM GRAPHICS	258116	TSH	TSH	RF
16MAY05	R	11	-	-		ALL APPLICABLE PARTS - MAT'L SPEC M3659423 WAS P003659423; ALL PARTS - ADDED 3 COLUMNS TO CHART	268254	JS	JS	LN
30MAY06	R	12	-	-		15454820 - UPDATED PDM ATTRIBUTES	281105	TLD	TLD	MJC
22SEP08	R	13	-	-		13722264 & 13722266 - RELEASED	406110	JOA	FKV	EJB
07OCT08	R	14	-	-		13722264 & 13722266 - REMOVED	406319	ACG	FKV	EJB
13NOV08	R	15	-	-		ALL PARTS - UPDATED MAT'L CALLOUT	406634	JHP	HAD	JHP
10MAY10	R	16	-	-		ALL PARTS - UPDATED PDM ATTRIBUTES	410242	JTZ	JTZ	VMR
09AUG10	R	17	-	-		ALL PARTS - ADDED PLATING NOTE, UPDATED MAT'L CALLOUT AND ADDED CONTACT AREA & CRIMP AREA COLUMNS ON CHART	411496	CBG	CBG	VMR
28SEP10	R	18	-	-		ALL PARTS - UPDATED "PLATING TYPE" NOTE	412094	JRL	JRL	VMR
04MAY11	R	19	-	-		ALL PARTS - DIM 2.35 +0.1/-0.05 WAS 2.35 ±0.05	414164	JAR	JAR	VMR
23MAY11	R	20	-	-		ALL PARTS - ADDED "PREFERRED MAT'L SIZE" COLUMN	414345	JAR	JAR	VMR
10MAY14	R	21	-	-		ALL PARTS - UPDATED PDM ATTRIBUTES	420617	CGD	ESC	DG
16JUN15	R	22	-	-		15454820 - REVISED GRAPHICS	429886	ABH	JVM	LES

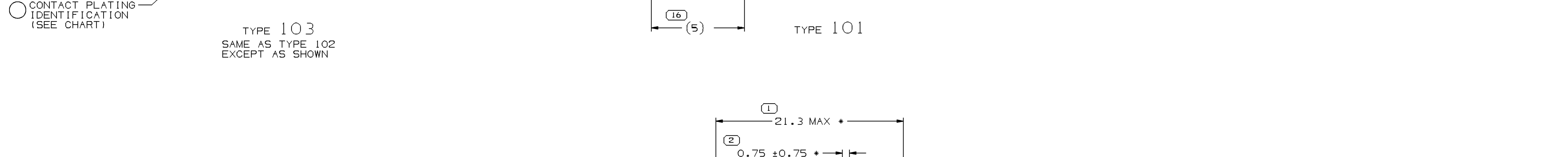
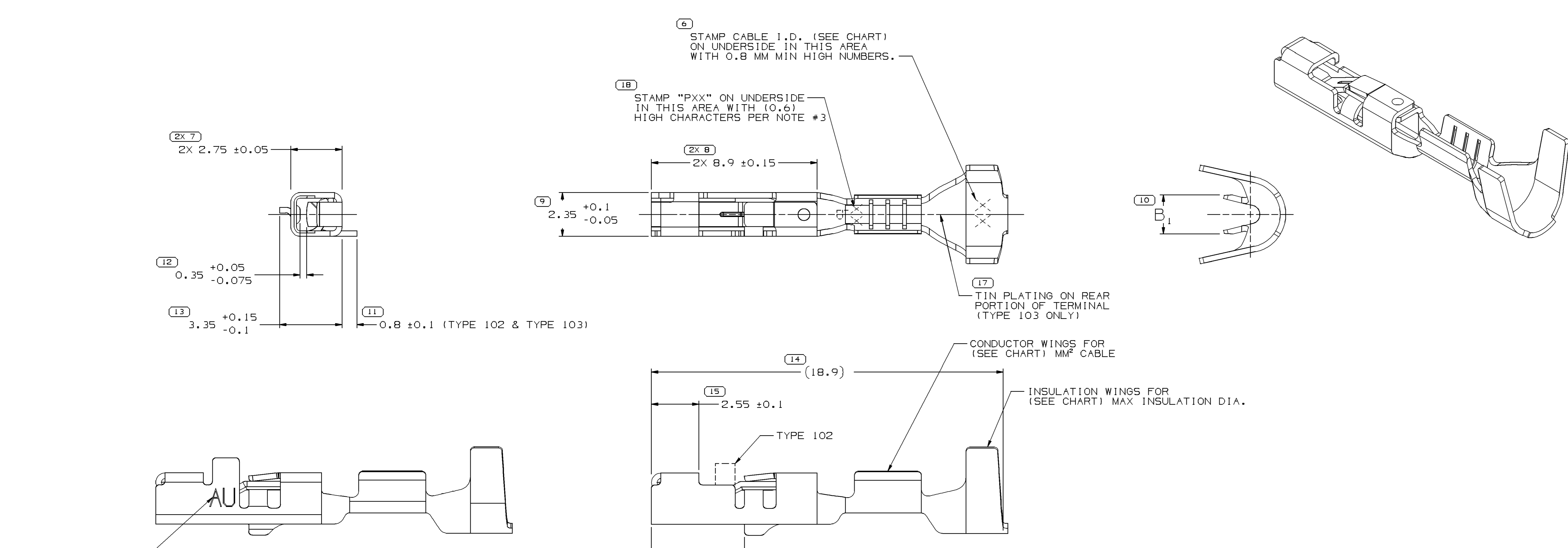

- NOTES
- UNLESS OTHERWISE SPECIFIED AND/OR INDICATED:
 - DIMENSIONS ARE TO FACE OF VIEW SHOWN AND AUTOMATICALLY ROUNDED BY COMPUTER FOR INSPECTION (SEE MATH MODEL FOR PRECISE DIMENSIONS). FOR ALL OTHER DIMENSIONS NOT SHOWN BUT REQUIRED FOR TOOL BUILD, SEE MATH MODEL FOR PRECISE TOOL PATH DATA.
 - "*" DENOTES DIMENSIONS MADE AT CUT-OFF AND CRIMP DIE.
 - "PXX" INDICATES "P" PLUS LAST TWO DIGITS OF MAKE DIE SERIES NUMBER (P01, P02, P03, ETC). STAMP MAY BE IN ANY CONFIGURATION. (0.6) HIGH TRIANGULAR CONFIGURATION IS PREFERRED.
 - REFERENCE MATING COMPONENTS OR EQUIVALENT:
 - TERMINAL - 15304704
 - DO NOT PROBE, TEST OR OTHERWISE CONTACT THE INTERIOR REGION (THE SPRING OR ANY MOVING PART) OF THIS TERMINAL. SEVERE DAMAGE CAN OCCUR, COMPROMISING THE PERFORMANCE OF THE ELECTRICAL INTERFACE.
 - PLATING TYPE:
 - I. REFLOW TIN 1.9 - 3.3 MICROMETERS THICK WITH A COPPER UNDERPLATE 0.5 MICROMETER TO 1.0 MICROMETER THICK.
 - II. MATE TIN ELECTROPLATE 1.9 - 7.0 MICROMETERS THICK.
 - III. 1.27 MICROMETERS DIFFUSED GOLD PALLADIUM/SILVER ALLOY INLAY OVER 1.27 MICROMETERS THICK NICKEL UNDERLAY.
- PLATING TYPE INFORMATION SHOWN ABOVE IS REFERENCE ONLY. PLATING REQUIREMENTS ARE CONTAINED IN APPLICABLE MATERIAL SPECIFICATION.

PART NO	REV	N/P	PREFERRED MAT'L SIZE	ALTERNATIVE MAT'L SIZE	MATERIAL DESCRIPTION	SIZE (MM ²)	ID	DIA	TYPE	B _{1,0.2}	APPLICATION	TYPICAL CABLE SEAL OR EQUIVALENT	TYPICAL SEALING CAVITY CONFIG	RESTRICTED USAGE	REPLACED BY	CONTACT AREA PLATING TYPE (SEE NOTE 6)	CRIMP AREA PLATING TYPE (SEE NOTE 6)
15454820	02	-	0.3 X 26.71	0.3 X 27.38	GOLD PLATED COPPER	0.35 - 0.5	21	1.85 - 1.2	103	2.1	SEALED (150MP)	SEE TAXI 12010295	Ø 5.2 ROUND	-	-	III	II
15369261	01	AK	0.3 X 26.71	0.3 X 27.38	SN PLATED COPPER	1 - 1.5	15	2.4 - 1.9	101	2.95	SEALED (GT)	15366060	Ø 4 ROUND	RESTRICTED	-	I	I
15305350	C18	-	0.3 X 26.71	0.3 X 27.38	SN PLATED COPPER	0.75 - 0.8	18	2.02 - 1.7	101	2.65	SEALED (MINI)	15305351	3.2 X 4 OVAL	RESTRICTED	15326267	I	I
15305130	C18	-	0.3 X 26.71	0.3 X 27.38	SN PLATED COPPER	0.35 - 0.5	21	1.85 - 1.2	101	2.1	SEALED (MINI)	15366022	3.2 X 4 OVAL	RESTRICTED	15326266	I	I
15305038	C16	-	0.3 X 26.71	0.3 X 27.38	SN PLATED COPPER	0.75 - 1	17	2.25 - 1.7	102	2.65	SEALED (150MP)	SEE TAXI 12010295	Ø 5.2 ROUND	RESTRICTED	-	I	I
15305037	C16	-	0.3 X 26.71	0.3 X 27.38	SN PLATED COPPER	0.35 - 0.5	21	1.85 - 1.2	102	2.1	SEALED (150MP)	SEE TAXI 12010295	Ø 5.2 ROUND	RESTRICTED	-	I	I
12191819	D16	-	0.3 X 26.71	0.3 X 27.38	SN PLATED COPPER	0.75 - 1	17	2.25 - 1.7	101	2.65	SEALED (GT)	15366060	Ø 4 ROUND	-	-	I	I
12191818	E16	-	0.3 X 26.71	0.3 X 27.38	SN PLATED COPPER	0.35 - 0.5	21	1.85 - 1.2	101	2.1	SEALED (GT)	15366021	Ø 4 ROUND	-	-	I	I
12191817	D16	-	0.3 X 26.71	0.3 X 27.38	SN PLATED COPPER	0.75 - 1	17	2.25 - 1.7	101	2.65	SEALED (150MP)	SEE TAXI 12010295	Ø 5.2 ROUND	-	-	I	I
12191816	D16	-	0.3 X 26.71	0.3 X 27.38	SN PLATED COPPER	0.35 - 0.5	21	1.85 - 1.2	101	2.1	SEALED (150MP)	SEE TAXI 12010295	Ø 5.2 ROUND	-	-	I	I

LINE DRAWN THROUGH * PART NUMBER INDICATES THAT PHYSICAL PARTS ARE NOT AVAILABLE FOR ORDERING.	INDICATES THAT PHYSICAL PARTS ARE NOT AVAILABLE FOR ORDERING.
PART NUMBERS THAT DO NOT HAVE A LINE PRESENT INDICATE THAT PHYSICAL PARTS ARE AVAILABLE FOR ORDERING.	INDICATES THAT PHYSICAL PARTS ARE AVAILABLE FOR ORDERING.
CONTACT DELPHI SALES TO ASSURE AVAILABILITY OF PARTS.	CONTACT DELPHI SALES TO ASSURE AVAILABILITY OF PARTS.
DWG TYPE	PART DRAWING
STYLE	
VOLUME (OMP)	DISTR CODE
	D
UNLESS OTHERWISE SPECIFIED THIS DOCUMENT IS IN ACCORDANCE WITH ASME Y14.5M-1994 AS MODIFIED BY THE LOCAL DIMENSIONING AND TOLERANCING (ASME Y14.5M-2001). SEPARATE PATTERNS OF FEATURES MAY BE DIMED SEPARATELY, REGARDLESS OF DATUM REFERENCES.	
ALL DIMENSIONS ARE IN MILLIMETERS	
DIMENSIONS ENCLOSED IN () INDICATE REFERENCE DIMENSIONS AND NO TOLERANCE LIMITS ARE ESTABLISHED	
DIMENSIONAL RANGE (MM)	CHART ID
FROM 0 TO 12	12
TOLERANCE UNLESS OTHERWISE SPECIFIED	
±0.1	
ANGULAR TOLERANCE 12°	
THIRD ANGLE PROJECTION	DO NOT SCALE
USE MATH DATA	

DELPHI
 DELPHI PACKARD ELECTRICAL/ELECTRONIC ARCHITECTURE
 WARREN, OH
 COPYRIGHT 1995 DELPHI CORPORATION AND/OR ITS AFFILIATES. ALL RIGHTS RESERVED.
 THIS DRAWING IS THE PROPERTY OF DELPHI CORPORATION AND CONTAINS DELPHI CONFIDENTIAL INFORMATION. THE REPRODUCTION, DISTRIBUTION AND UTILIZATION OF THIS DOCUMENT OR ITS RELATED CAD DATA, AS WELL AS COMMUNICATION OF ANY CONTENT TO OTHERS, WITHOUT EXPRESS AUTHORIZATION, IS PROHIBITED.

DATE

DR

APVD1 J. VILLAMIL 07DEC95

APVD2 MANUEL VEGA 08DEC95

APVD3 ERIC HSIEH 01AP96

APVD4

SUBSTANCE OF CONCERN AND RECYCLED CONTENT PER DELPHI 1049901

MATERIAL: COPPER ALLOY

DRAWING NAME

TAXI TERM F 0T 150

DRAWING NUMBER

12191815

SIZE A0 SCALE 10:1 FRAME NO 1 OF 1 SHEET NO 1 OF 5 STG REV N/P 22 -

X-ON Electronics

Largest Supplier of Electrical and Electronic Components

Click to view similar products for [Automotive Connectors](#) category:

Click to view products by [APTIV](#) manufacturer:

Other Similar products are found below :

[003-018-000](#) [60403001](#) [60993906-B](#) [629515004020001](#) [M902-2131](#) [M902-2161](#) [72.330.1035.1](#) [73.353.4028.0](#) [F119300-B](#) [F166900](#)
[F258300-B](#) [F358300-B](#) [F407400](#) [F444110](#) [F487000](#) [F509500B-B](#) [827153-1](#) [8N1515-32-24P](#) [9-1326729-8](#) [925474-1](#) [928905-1](#) [964562-4](#)
[968782-1](#) [GT17SA-8DS-HU](#) [98891-1012](#) [98947-1016](#) [12004475-L](#) [12010290](#) [12010309-B](#) [12015454](#) [12020219-B](#) [12020308](#) [12041318-B](#)
[12052225-L](#) [12052466](#) [12059125](#) [12064869](#) [12004327-B](#) [12010503-B](#) [12015308](#) [12015384](#) [12015909](#) [1-21030-1](#) [12041254](#) [12041318](#)
[12047946-B](#) [12047957](#) [12047957-L](#) [12059473](#) [12066261](#)