

SYMBOL DEFINITION		MISSING SYMBOLS	
A DIMENSION WITHOUT AN INSPECTION REPORT SYMBOL DOES NOT REQUIRE INSPECTION. IT MAY BE CONTROLLED ON THE INDIVIDUAL COMPONENT DRAWING.	TOTAL NO OF INSPECTIONS REQUIRED	NO MISSING SYMBOL NUMBER	
	8		
	LAST NO. USED	7	

DWO STATUS				REVISION HISTORY				AUTH	DR	APVD	APVD
DATE	STG	REV	N/P	CHG	ZONE						
16JUL02	R	D2	-	-	-	CLEARED REV COL AND REVISED MAT'L SPEC	227822	ARA	RH	JDV	
21FEB05	R	D3	-	-	-	ADDED PROCESSING NOTES AND REVISED MATERIAL DESCRIPTION	264729	MDH	JVM	JAS	

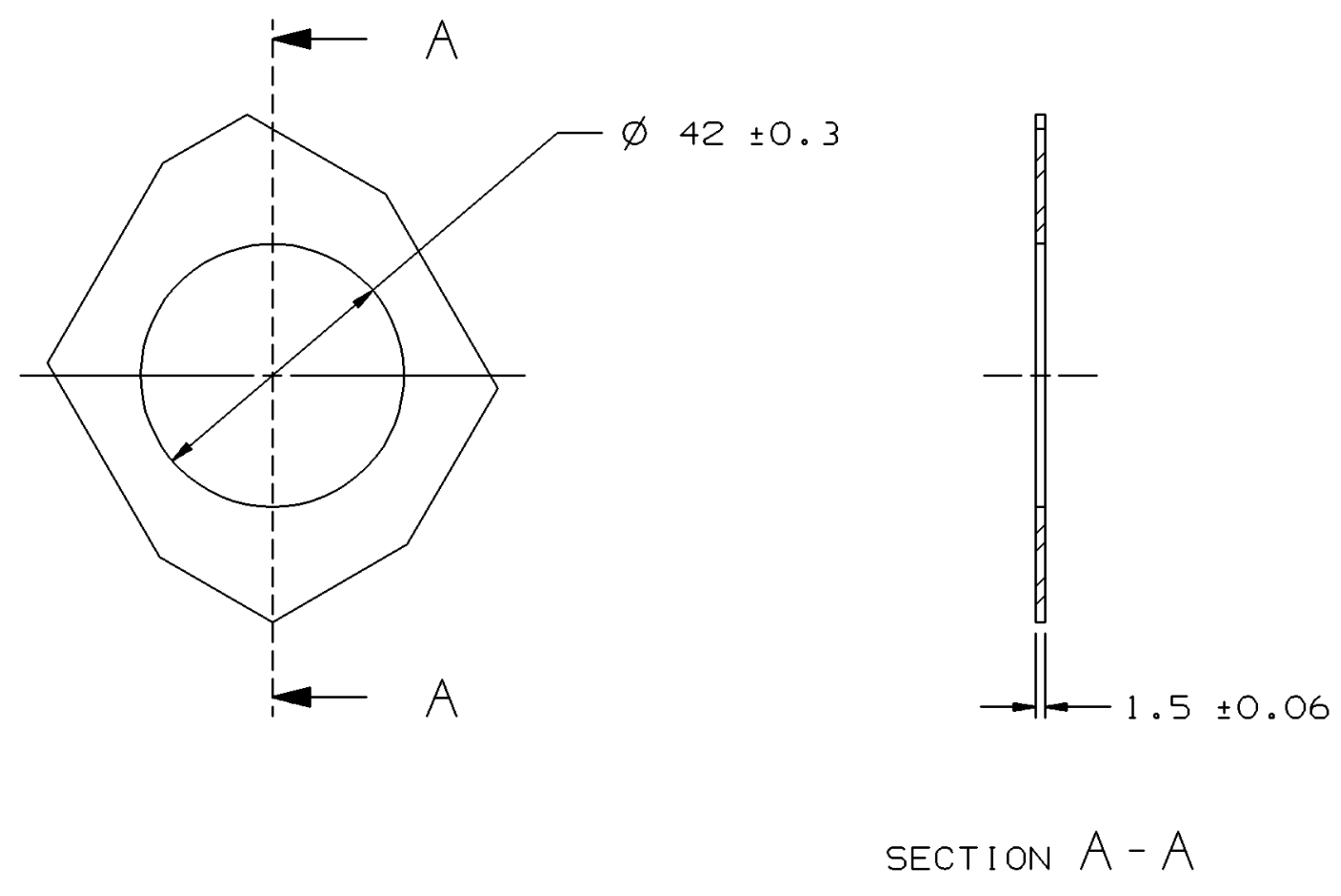

MOUNTING HOLE INFORMATION  
SCALE 1:1

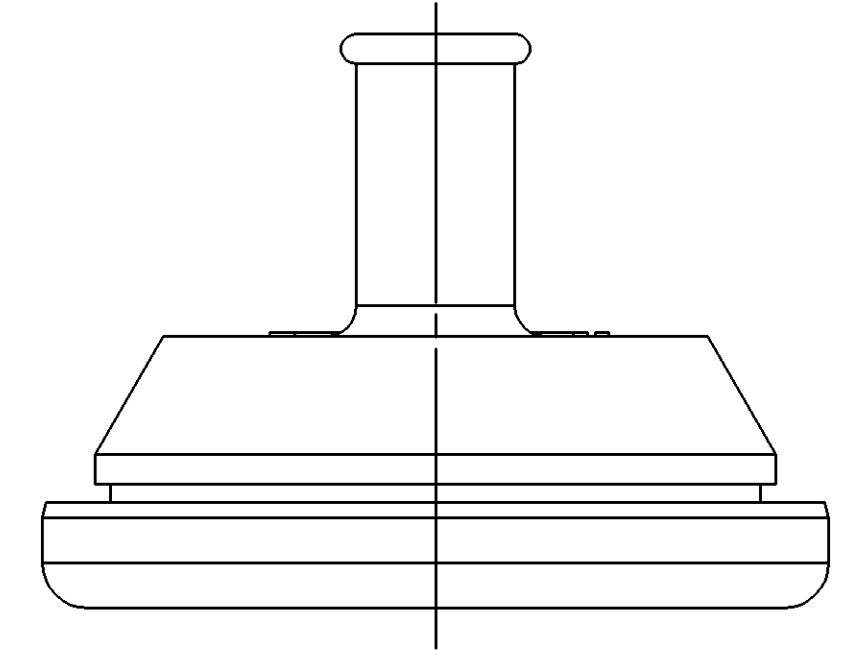
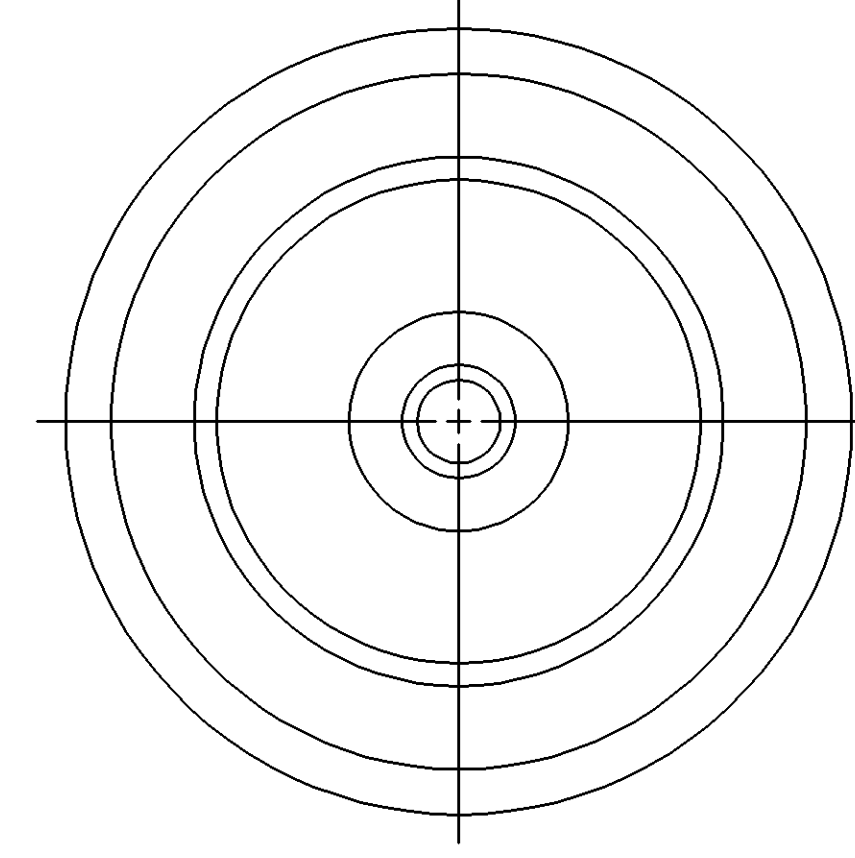
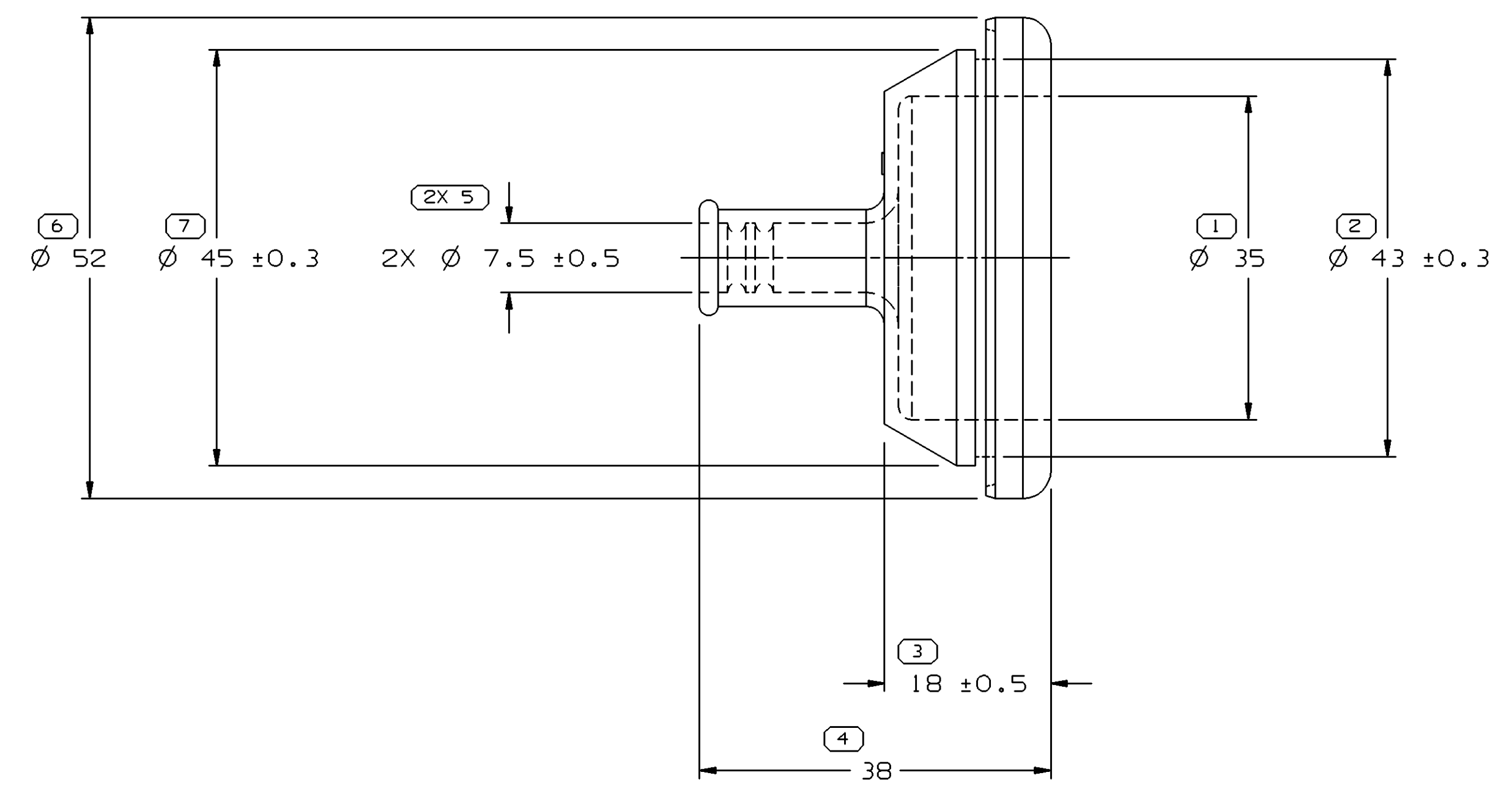
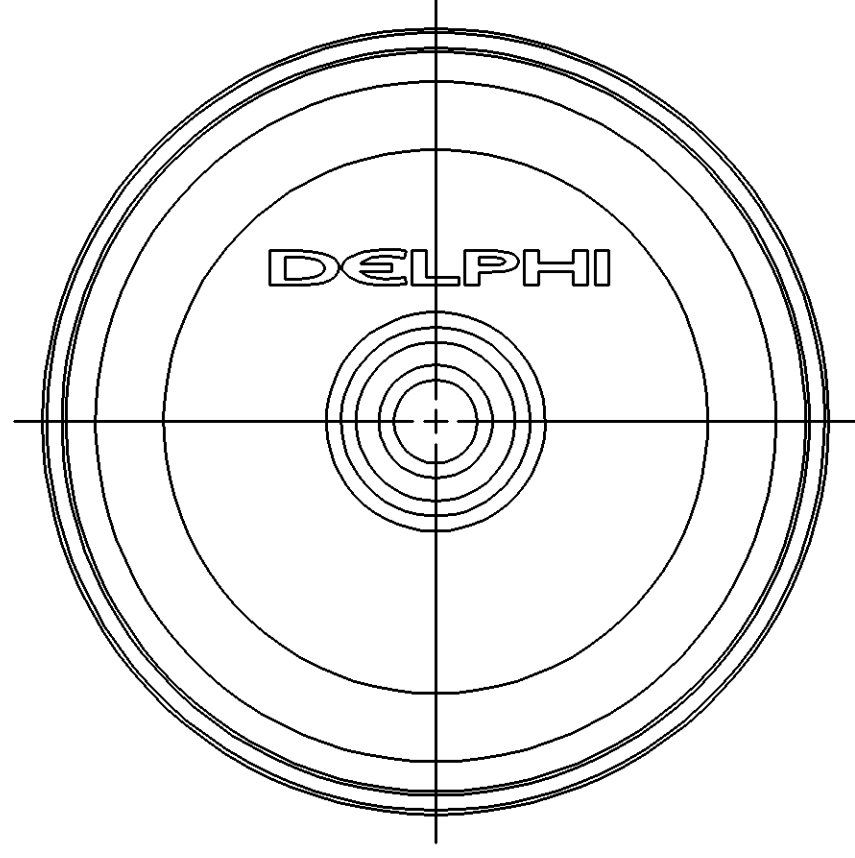

NOTES

- UNLESS OTHERWISE SPECIFIED AND/OR INDICATED:  
DIMENSIONS ARE TO FACE OF VIEW SHOWN AND AUTOMATICALLY ROUNDED BY COMPUTER FOR INSPECTION (SEE MATH MODEL FOR PRECISE DIMENSIONS). FOR ALL OTHER DIMENSIONS NOT SHOWN BUT REQUIRED FOR TOOL BUILD, SEE MATH MODEL FOR PRECISE TOOL PATH DATA.
- PART IS SYMMETRICAL ABOUT CENTERLINES.
- SEALING SURFACES MUST BE FREE OF SINK, NFO, VOIDS, KNIT/FLOW LINES, ETC.
- THIS GROMMET TO BE USED WITH HARNESS BUNDLE SMOOTH TAPE WRAPPED USING 5 MIL TAPE HAVING NO SLITS ON EDGES.
- THIS GROMMET IS DESIGNED FOR USE ON A Ø 6 MM MIN HARNESS BUNDLE.
- (2.3)X(0.1) RAISED DELPHI CORPORATE BRAND TO BE LOCATED ON ANY EXTERIOR SURFACE, PREFERABLY VISIBLE AT FINAL ASSEMBLY. OPTIONAL CONSTRUCTION TO BE "PED" OR NO LOGO.

PROCESSING NOTES:

- THE FOLLOWING NUMBER IS TO BE PUT ON THE PRODUCT DRAWING AS THE MAXIMUM ALLOWABLE STRETCH DIMENSION: 22 MM AS MEASURED IN THE FOLLOWING FASHION:

MAXIMUM ALLOWABLE DIMENSION OF STRETCHED GROMMET NECK WHEN USING A 4 BILL SPREADER

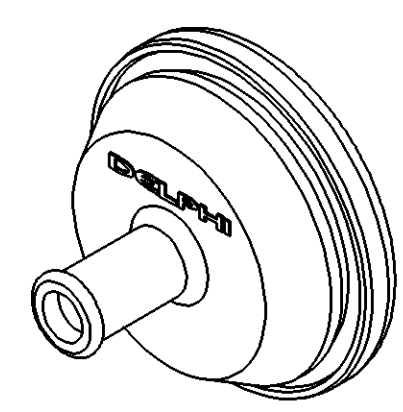
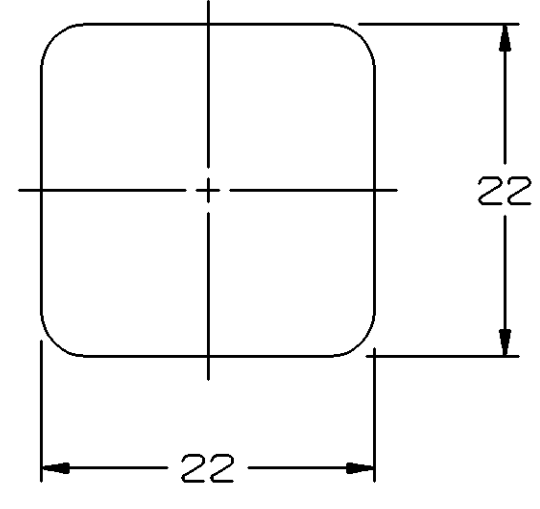

2 PROCESS SENSITIVE DIMENSION	
DIMENSIONAL RANGE (MM)	CHART C
FROM > 0	> 25
TO ≤ 60	> 80
TOLERANCE UNLESS OTHERWISE SPECIFIED	
±0.3	±0.5
±0.6	±0.75
ANGULAR TOLERANCE 12°	

DWO TYPE		PART DRAWING	
STYLE		DISTR CODE	D
VOLUME (OP)	14,144		
UNLESS OTHERWISE SPECIFIED			
THIS DOCUMENT IS IN ACCORDANCE WITH ASME Y14.5M-1994 AS AMENDED BY THE 2003 ADDENDUM AND TOLERANCING ADDENDUM - 1997. ALL GEOMETRIC TOLERANCES AND RELATED DATUM APPLY UNLESS OTHERWISE SPECIFIED. UNLESS OTHERWISE SPECIFIED, ALL DIMENSIONS ARE IN MILLIMETERS.			
REFERENCE		THIRD ANGLE PROJECTION	DO NOT SCALE
		USE MATH DATA	UNGRAPHS

**DELPHI**  
DELPHI PACKARD ELECTRIC SYSTEMS  
WARREN, OH

DR	DATE
APVD1 H. CASTRILLON	180C96
APVD2 R. RAMOS S.	180C96
APVD3 JIM GRIFFIN	12N096
APVD4	
APVD5	

MATERIAL: M4433002  
SUBSTANCES OF CONCERN AND RECYCLED CONTENT PER DELPHI 10949001

DRAWING NAME: GROM TAPE ON  
DRAWING NUMBER: 12191564

SIZE: AO  
SCALE: 2:1  
FRAME NO: 1 OF 1  
SHEET NO: 1 OF 1  
REV: R D3

## X-ON Electronics

Largest Supplier of Electrical and Electronic Components

*Click to view similar products for [Automotive Connectors](#) category:*

*Click to view products by [APTIV](#) manufacturer:*

Other Similar products are found below :

[003-018-000](#) [60403001](#) [60993906-B](#) [M902-2131](#) [M902-2161](#) [72.330.1035.1](#) [73.353.4028.0](#) [F119300-B](#) [F166900](#) [F258300-B](#) [F358300-B](#)  
[F407400](#) [F444110](#) [F487000](#) [F509500B-B](#) [827153-1](#) [8N1515-32-24P](#) [9-1326729-8](#) [925474-1](#) [928905-1](#) [964562-4](#) [968782-1](#) [GT17SA-8DS-](#)  
[HU](#) [98891-1012](#) [98947-1016](#) [12004475-L](#) [12010290](#) [12010309-B](#) [12015454](#) [12020219-B](#) [12020308](#) [12041318-B](#) [12052225-L](#) [12052466](#)  
[12059125](#) [12064869](#) [12004327-B](#) [12010503-B](#) [12015308](#) [12015384](#) [12015909](#) [1-21030-1](#) [12041254](#) [12041318](#) [12047946-B](#) [12047957](#)  
[12047957-L](#) [12059473](#) [12066261](#) [12110546](#)