

SYMBOL DEFINITION		TOTAL NO OF INSPECTIONS REQUIRED		MISSING SYMBOLS	
A	DIMENSION WITHOUT AN INSPECTION REPORT SYMBOL DOES NOT REQUIRE INSPECTION. IT MAY BE CONTROLLED ON THE INDIVIDUAL COMPONENT DRAWING.			NO MISSING SYMBOL NUMBER	
		4			
		LAST NO. USED	4		

DWS STATUS		REVISION HISTORY		AUTH		DR		APVD	
DATE	STG	REV	N/P	CHG	ZONE				
21AUG08	R	01	-	-		13663718, 13663719, 13663720, 13690835, 13690836, 13690837, 13697414, 13697415, 13697416, 13697417, 13697418 & 13697419 RELEASED	401819	END	END
10AUG09	R	02	-	-		ALL PARTS - DIM Ø 3.34 ± 0.05 WAS Ø 3.34 +0.15/-0	408568	ECB	AUG P6D
18AUG09	R	03	-	-		ALL PARTS - REVISED NOTE #3	408674	ECB	AUG P6D
27OCT09	R	04	-	-		ALL PARTS - ADDED LUBRICATION NOTE #4	409315	JTZ	FKV P6D
02JUL10	R	05	-	-		ALL PARTS - UPDATED PDM ATTRIBUTES	411272	ESC	ESC P6D
10DEC10	R	06	-	-		13697414 & 13697417 - CABLE DIA 1.4-2.15 WAS 1.8-1.87	412856	CBG	CBG P6D
07MR11	R	07	-	-		ALL PARTS - ADDED TERMINAL NOTES	413478	ARC	ARC P6D
27MY11	R	08	-	-		ALL PARTS - ADDED ASSEMBLY NOTE	414410	JTZ	JTZ P6D
03JUN11	R	09	-	-		ALL PARTS - UPDATED PDM ATTRIBUTES	414463	JCF	JAA P6D
09SEP11	R	10	-	-		ALL PARTS - REMOVED "MAX CURRENT CAPACITY" & "INSULATION CRIMP" NOTES	415284	AJP	JVM P6D
14OCT11	R	11	-	-		ALL PARTS - ADDED TERMINAL APPLICATION INFORMATION NOTE	415778	JCF	JVM P6D
01FEB13	R	12	-	-		ALL PARTS - UPDATED PDM ATTRIBUTES	421280	CER	CER P6D

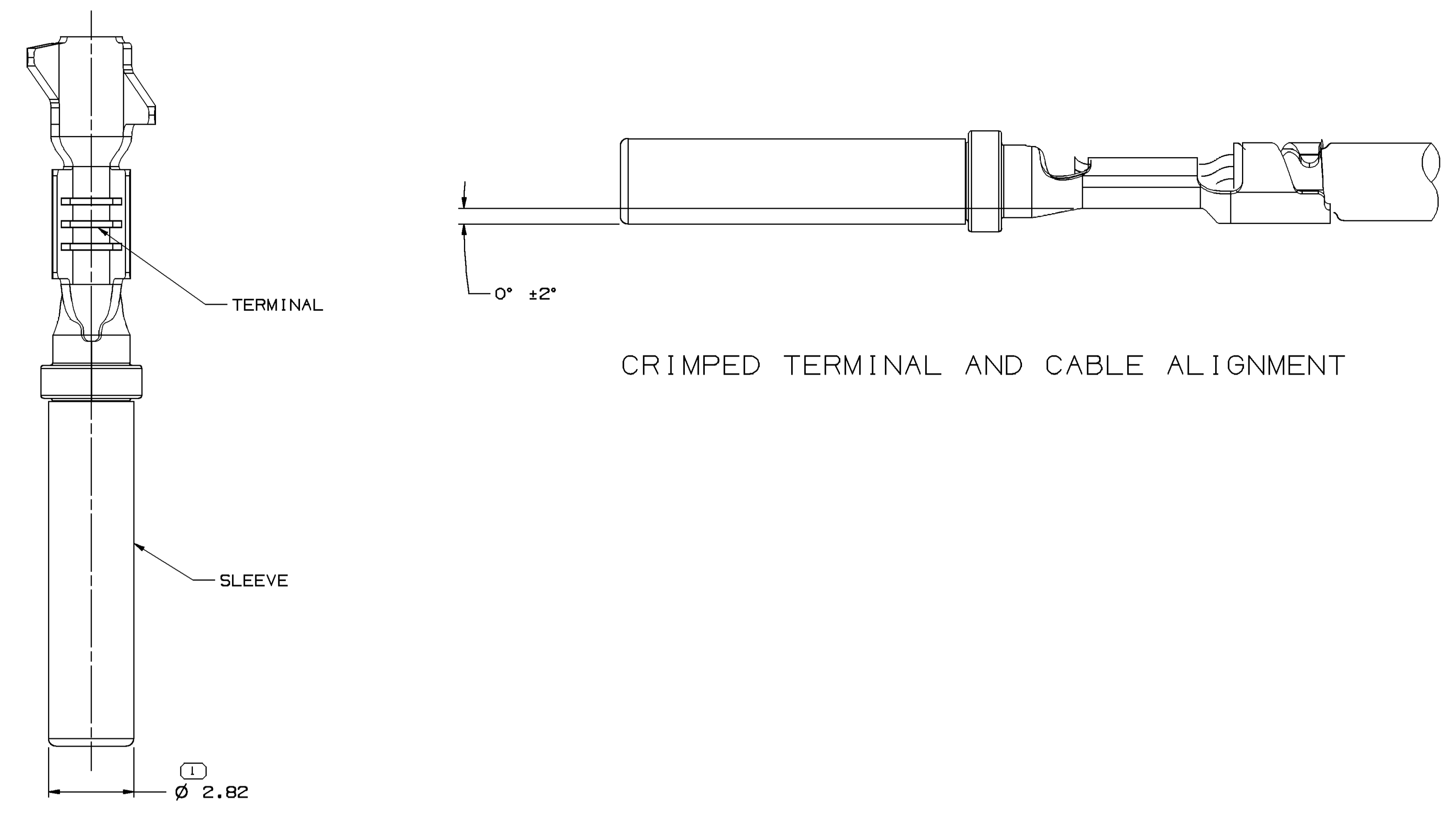

CRIMPED TERMINAL AND CABLE ALIGNMENT

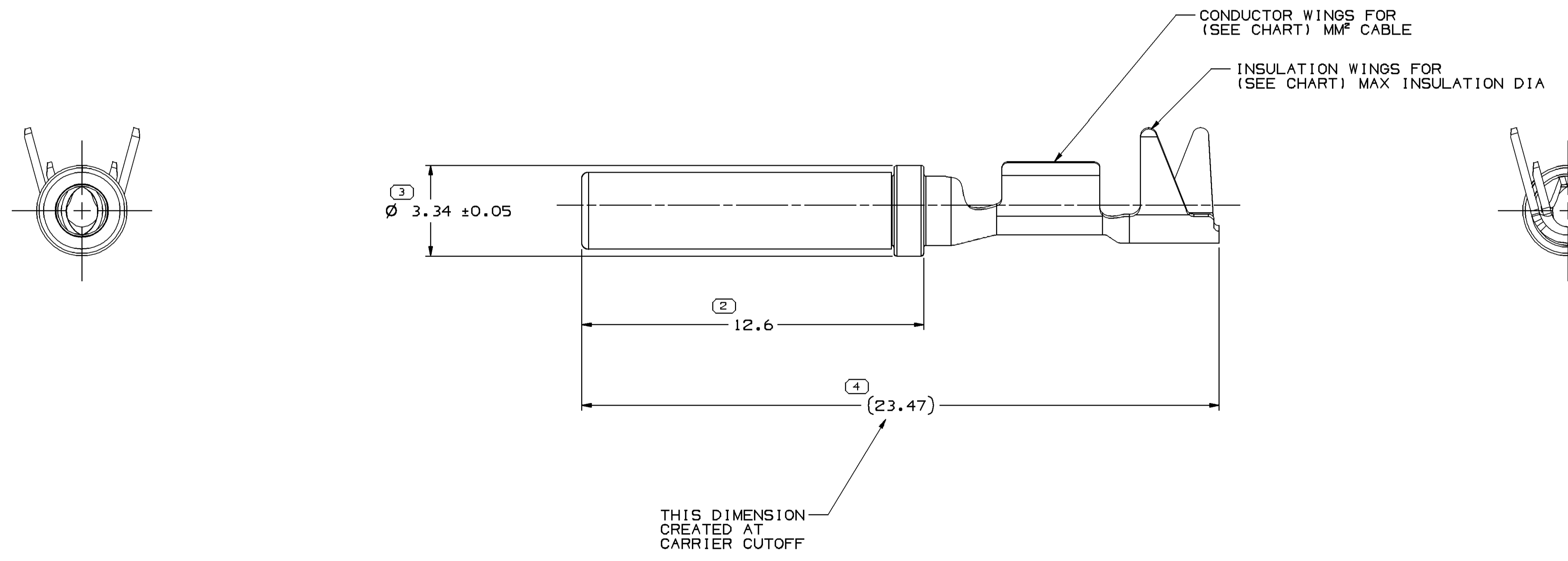
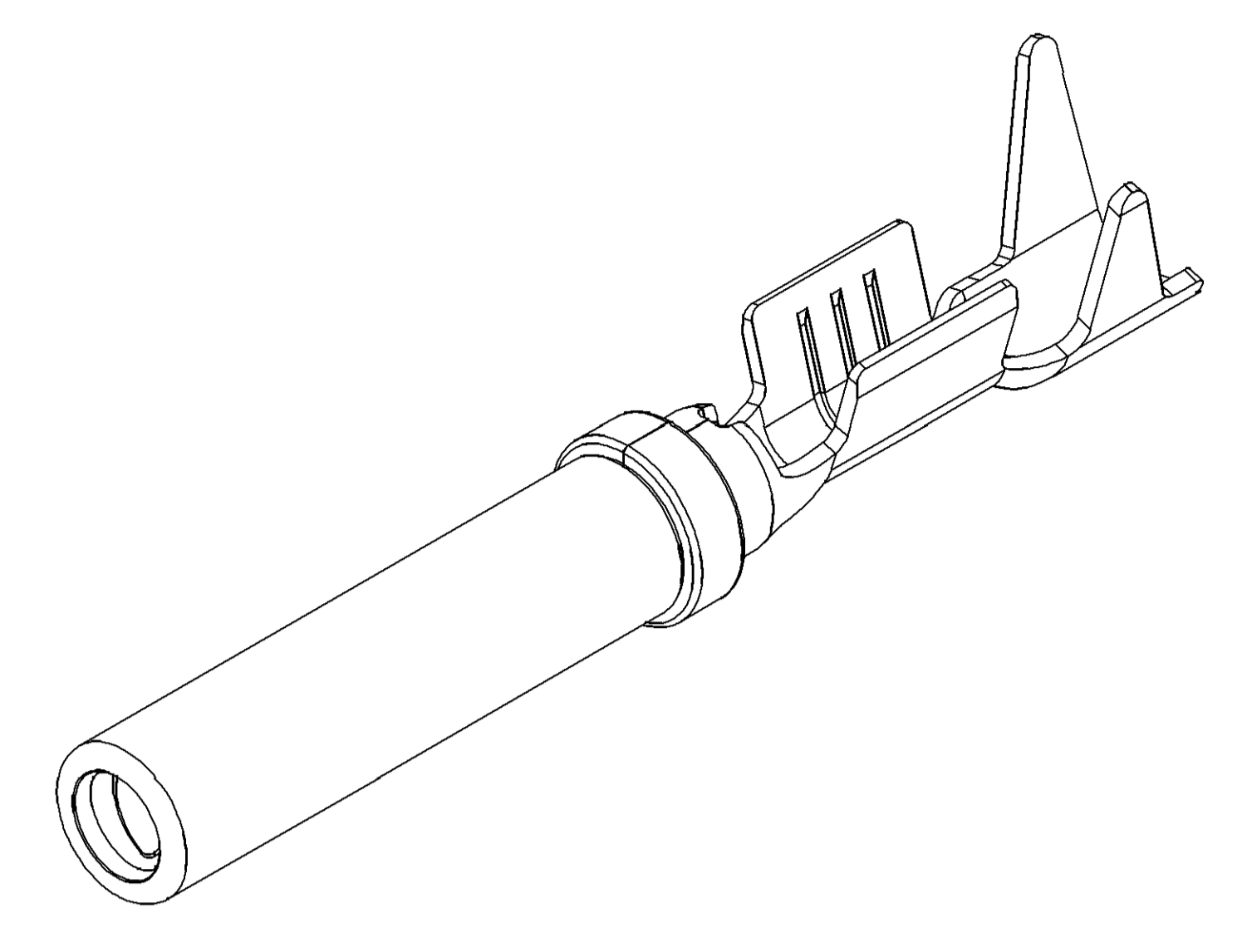

NOTES

- UNLESS OTHERWISE SPECIFIED AND/OR INDICATED: DIMENSIONS ARE TO FACE OF VIEW SHOWN AND AUTOMATICALLY ROUNDED BY COMPUTER FOR INSPECTION (SEE MATH MODEL FOR PRECISE DIMENSIONS). FOR ALL OTHER DIMENSIONS NOT SHOWN BUT REQUIRED FOR TOOL BUILD, SEE MATH MODEL FOR PRECISE TOOL PATH DATA.
- TERMINAL MUST BE MADE BY APPLYING NYE 1486 LUBE OIL OR EQUIVALENT (PREFERRED WITH A FLUORESCENT TRACE ADDED), AFTER STAMPING (OR FINAL PROCESS PRIOR TO SHIPPING). NYE 1486 MUST BE PRESENT ON THE MATING INTERFACE AREA AND ON THE OUTSIDE SURFACE OF THE CORE CRIMP WINGS. THE RECOMMENDED APPLICATION METHOD RATE UTILIZES A QUANTITY OF 0.75 GALLONS MINIMUM PER 1 MILLION TERMINALS. ANY OTHER LUBRICANT MUST BE APPROVED BY DELPHI CONNECTION SYSTEMS PRODUCT ENGINEERING. THE NYE 1486 OIL CAN ALSO BE APPLIED DURING THE STAMPING OPERATION AT A RATE OF 50% NYE 1486 AND 50% FIN LUBE 177 (SUPPLIED BY PPG).
- TERMINAL CAN BE USED IN ANY 1.6 MM (SIZE 16 MIL 39029) INDUSTRY STANDARD CAVITY EXAMPLES - DEUTSCH DT, AMPSEAL 16
- TERMINAL IS DIRECT REPLACEMENT FOR (EQUIVALENT TO) THE DEUTSCH 1062-16-XXXX FAMILY OF STAMPED AND FORMED CONTACTS
- REFER TO DRAWING NUMBER 13922721 FOR TERMINAL APPLICATION INFORMATION (CURRENT CARRYING CAPABILITY, CABLE CRIMP RANGE, ETC.)

MATERIAL NOTES :

TERMINAL: COPPER ALLOY - 0.30 THK
SLEEVE: STAINLESS STEEL - 0.13 THK

ASSEMBLY NOTE :

- SLEEVE MUST WITHSTAND PULL-OFF FORCE IN DIRECTION PARALLEL TO CENTER OF TERMINAL OF 60 NEWTONS MIN.

PART NO	REV	N/P	STATUS	CONTACT PLATING	SIZE (MMF)	ID	DIA	MATING TERM
13697419	01	AK	-	GOLD	2-3	13T	2.4-3.31	13697413
13697418	01	AK	-	GOLD	1-1.5	15T	1.8-2.45	13697412
13697417	01	AL	-	GOLD	0.5-0.8	19T	1.4-2.15	13697411
13697416	01	AK	-	NICKEL	2-3	13T	2.4-3.31	13697410
13697415	01	AK	-	NICKEL	1-1.5	15T	1.8-2.45	13697409
13697414	01	AL	-	NICKEL	0.5-0.8	19T	1.4-2.15	13697408
13690837	01	AK	-	GOLD	2-3	13	2.89-3.67	13690840
13690836	01	AK	-	GOLD	1-1.5	15	2.4-3	13690839
13690835	01	AK	-	GOLD	0.5-0.8	19	2-2.78	13690838
13663720	01	AK	-	NICKEL	2-3	13	2.89-3.67	13663717
13663719	01	AK	-	NICKEL	1-1.5	15	2.4-3	13663716
13663718	01	AK	-	NICKEL	0.5-0.8	19	2-2.78	13663715

DELPHI
DELPHI PACKARD ELECTRICAL/ELECTRONIC ARCHITECTURE
WARREN, OH
COPYRIGHT 2008 DELPHI CORPORATION AND/OR ITS AFFILIATES. ALL RIGHTS RESERVED.
THIS DRAWING IS THE PROPERTY OF DELPHI CORPORATION AND CONTAINS DELPHI CONFIDENTIAL INFORMATION. THE REPRODUCTION, DISTRIBUTION AND UTILIZATION OF THIS DOCUMENT OR ITS CONTENTS OR DATA, AS WELL AS COMMUNICATION OF ANY CONTENT TO OTHERS, WITHOUT EXPRESS AUTHORIZATION, IS PROHIBITED.

DATE: 01-FEB-13 Time: 08:49

INDICATES THAT PHYSICAL PARTS ARE NOT AVAILABLE FOR ORDERING.
PART NUMBERS THAT DO NOT HAVE A LINE PRESENT INDICATE THAT PHYSICAL PARTS ARE AVAILABLE FOR ORDERING.
CONFIRM DELPHI SALES TO ASSURE AVAILABILITY OF PARTS.
REVISED SOL

DWG TYPE: PART DRAWING

STITLE: TAXI ASM TERM F HES 1.6

VOLUME (QWP): 1
DISTR CODE: D

UNLESS OTHERWISE SPECIFIED
THIS DOCUMENT IS IN ACCORDANCE WITH ASME Y14.5M-1994 AS MODIFIED BY THE 2003 GLOBAL DIMENSIONING AND TOLERANCING ADDENDUM - 1997. ALL GEOMETRIC TOLERANCES ARE RELATED UNLESS OTHERWISE SPECIFIED. DIMENSIONS ARE IN MILLIMETERS UNLESS OTHERWISE SPECIFIED.
SEPARATE POSITION CALLOUTS MAY BE SAVED SEPARATELY, IRRESPECTIVE OF DIMENSION REFERENCE.
ALL DIMENSIONS ARE IN MILLIMETERS

THIRD ANGLE PROJECTION
DO NOT SCALE
USE MATH DATA

ANGULAR TOLERANCE: ±2°

DATE: 01-FEB-13 Time: 08:49

OR: E-NEAL DUNHAM, R-POLENICK

APVD: E-NEAL DUNHAM, R-POLENICK

APVD3: R-POLENICK

APVD4: [Blank]

APVD5: [Blank]

SUBSTANCES OF CONCERN AND RECYCLED CONTENT PER DELPHI 10949001

MATERIAL: SEE MATERIAL NOTES

DRAWING NAME: TAXI ASM TERM F HES 1.6

DRAWING NUMBER: 13654419

SIZE: A0
SCALE: 10:1
FRAME NO: 1 OF 1
SHEET NO: 1 OF 1
STG: R
REV: 12

X-ON Electronics

Largest Supplier of Electrical and Electronic Components

Click to view similar products for [Automotive Connectors](#) category:

Click to view products by [APTIV](#) manufacturer:

Other Similar products are found below :

[003-018-000](#) [60403001](#) [60993906-B](#) [629515004020001](#) [M902-2131](#) [M902-2161](#) [72.330.1035.1](#) [73.353.4028.0](#) [F119300-B](#) [F166900](#)
[F258300-B](#) [F358300-B](#) [F407400](#) [F444110](#) [F487000](#) [F509500B-B](#) [827153-1](#) [8N1515-32-24P](#) [9-1326729-8](#) [925474-1](#) [928905-1](#) [964562-4](#)
[968782-1](#) [GT17SA-8DS-HU](#) [98891-1012](#) [98947-1016](#) [12004475-L](#) [12010290](#) [12010309-B](#) [12015454](#) [12020219-B](#) [12020308](#) [12041318-B](#)
[12052225-L](#) [12052466](#) [12059125](#) [12064869](#) [12004327-B](#) [12010503-B](#) [12015308](#) [12015384](#) [12015909](#) [1-21030-1](#) [12041254](#) [12041318](#)
[12047946-B](#) [12047957](#) [12047957-L](#) [12059473](#) [12066261](#)