

SYMBOL DEFINITION		MISSING SYMBOLS	
A DIMENSION WITHOUT AN INSPECTION REPORT SYMBOL DOES NOT REQUIRE INSPECTION. IT MAY BE CONTROLLED ON THE INDIVIDUAL COMPONENT DRAWING.	TOTAL NO OF INSPECTIONS REQUIRED	NO MISSING SYMBOL NUMBER	14
	LAST NO. USED		14

DWG STATUS		ZONE		REVISION HISTORY		AUTH	DR	APVD1	APVD2
DATE	STG	REV	N/P	CHG					
30JUL02	R	14	-	-	CLEARED REV COLUMN; ALL PARTS - UPDATED PDM ATTRIBUTES	226419	LOA	FRG	TTP
24JA03	R	15	-	-	ADVANCED REVISION LEVEL	235918	LMB	LMB	TV
22JUL03	R	16	-	-	ADDED DIM 2.75±0.1 FOR SPRING BACK	243779	RH	RH	SCH
23JA04	R	17	-	-	ADVANCED REVISION LEVEL	251141	LMB	LMB	LN
24SE04	R	18	-	-	ADDED TERMINAL I.D. NOTE	259075	MDH	AUG	MKM
130C04	R	19	-	-	15304710-12 - UPDATED PDM ATTRIBUTES	259807	FKV	FKV	MY
09MY05	R	20	-	-	15345940 - RELEASED	267887	GLG	JVM	CM
14DE05	R	21	-	-	ALL PARTS - UPDATED PDM ATTRIBUTES	275556	CJP	CJP	MC
09MR06	R	22	-	-	12191133, 15304710-13 - UPDATED PDM ATTRIBUTES	276501	JBD	AUG	JES
04SE08	R	23	-	-	13723823 - RELEASED	405955	JOA	FKV	SLS
25SE08	R	24	-	-	13734673 - RELEASED	406226	VMR	JHP	VMR
27OC08	R	25	-	-	15304710-13, 12191133-35, 13734673, 15336198, 15427675 & 13723823 - UPDATED MATERIAL CALLOUT	406610	VMR	HAD	VMR
12MR10	R	26	-	-	15304710-13, 12191133-35, 15336198, 15427675, 13723823 & 13734673 - UPDATED PDM ATTRIBUTES	410214	FRE	FRE	VMR
04AU10	R	27	-	-	ALL PARTS - ADDED PLATING NOTE, UPDATED MAT'L CALLOUT AND ADDED CONTACT AREA & CRIMP AREA COLUMNS ON CHART	411499	JRL	JRL	VMR
11OC10	R	28	-	-	ALL PARTS - UPDATED PLATING NOTES	412162	CBG	CBG	MAC
14DE10	R	29	-	-	ALL PARTS - UPDATED PDM ATTRIBUTES	412882	VMR	VMR	VMR
14JA11	R	30	-	-	ALL PARTS - ADDED PREFERRED MAT'L SIZE COLUMN ON CHART & ALTERNATIVE MAT'L SIZE COLUMN WAS MAT'L SIZE COLUMN	413061	VMR	VMR	VMR
28MR11	R	31	-	-	ALL PARTS - INVERTED ALTERNATIVE & PREFERRED MAT'L SIZE COLUMN POSITIONS ON CHART	413780	VMR	VMR	VMR
11OC12	R	32	-	-	UPDATED PDM ATTRIBUTES	419973	IMF	JVM	DBL

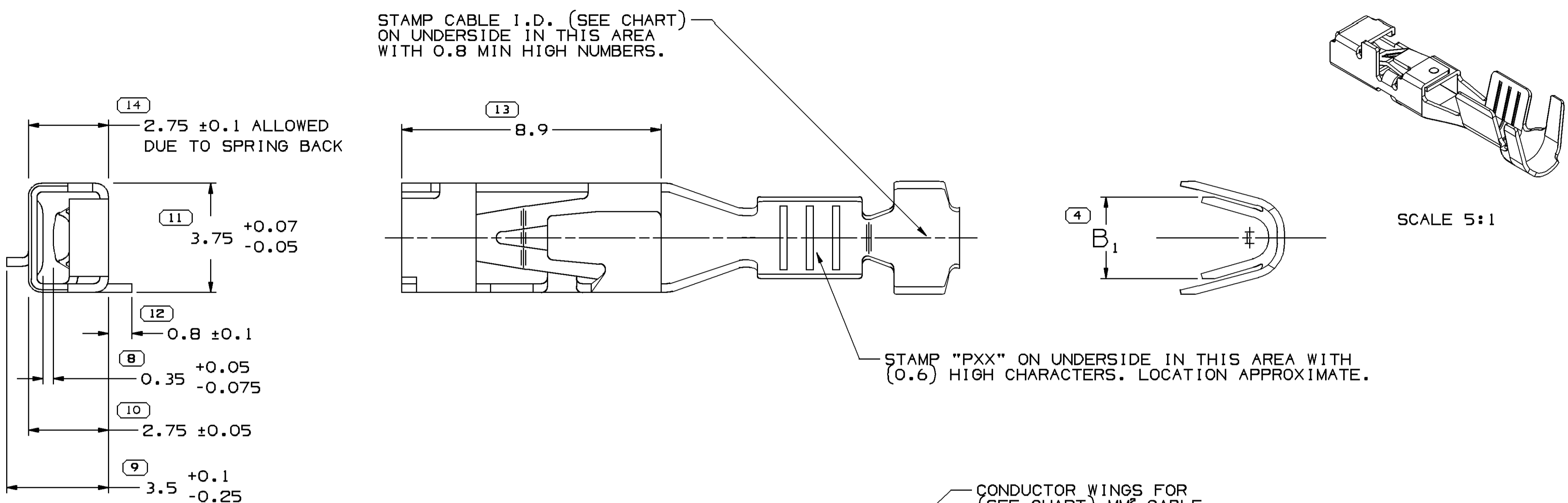

STAMP CABLE I.D. (SEE CHART) ON UNDERSIDE IN THIS AREA WITH 0.8 MIN HIGH NUMBERS.

STAMP "PXX" ON UNDERSIDE IN THIS AREA WITH (0.6) HIGH CHARACTERS. LOCATION APPROXIMATE.

CONDUCTOR WINGS FOR (SEE CHART) MM² CABLE

INSULATION WINGS FOR (SEE CHART) MAX INSULATION DIA

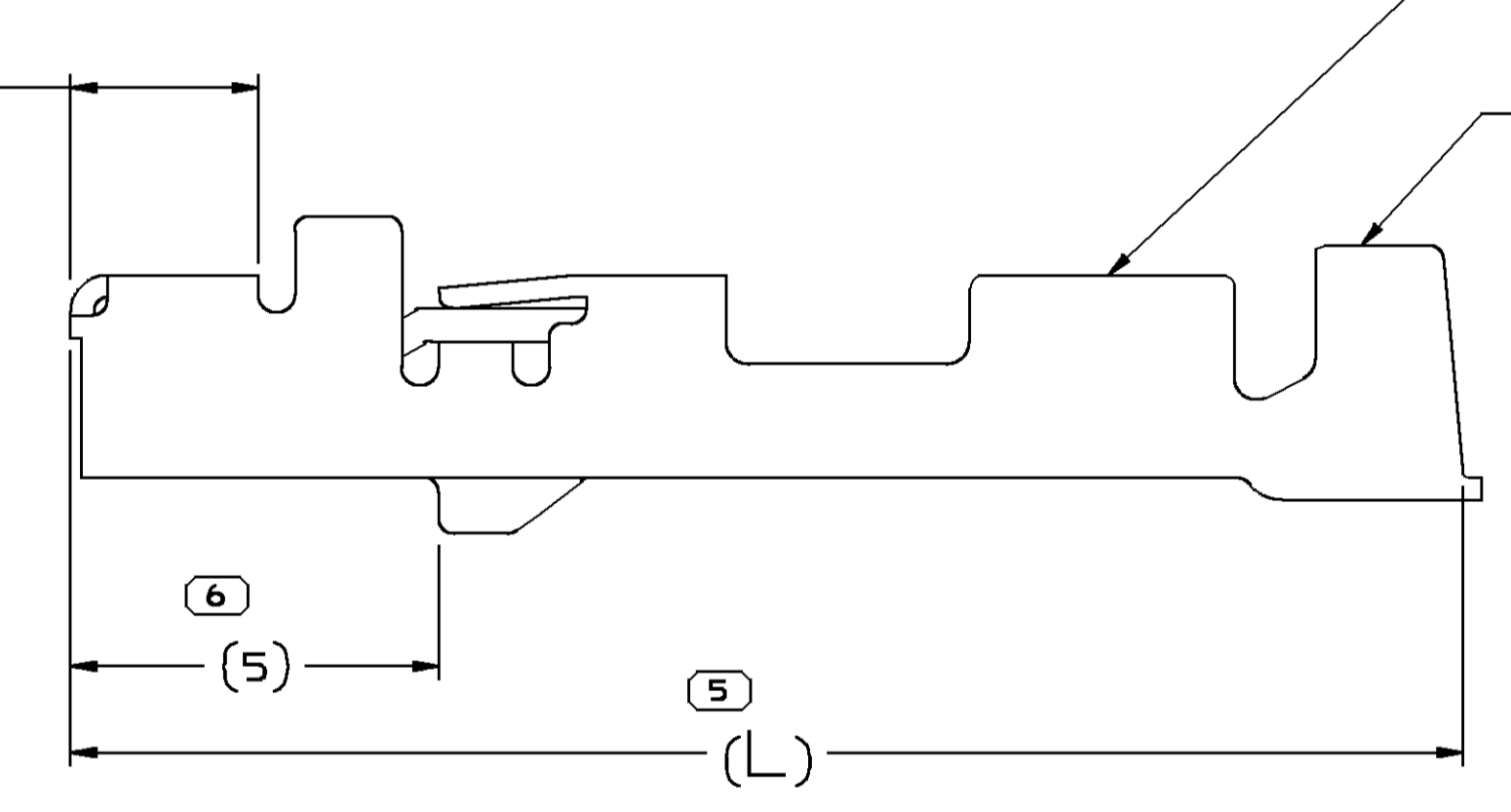

NOTES

- UNLESS OTHERWISE SPECIFIED AND/OR INDICATED:
DIMENSIONS ARE TO FACE OF VIEW SHOWN AND AUTOMATICALLY ROUNDED BY COMPUTER FOR INSPECTION (SEE MATH MODEL FOR PRECISE DIMENSIONS). FOR ALL OTHER DIMENSIONS NOT SHOWN BUT REQUIRED FOR TOOL BUILD, SEE MATH MODEL FOR PRECISE TOOL PATH DATA.
 - REFERENCE MATING COMPONENTS OR EQUIVALENT:
TERMINAL 15304722
 - * DENOTES DIMENSIONS MADE AT CUT-OFF AND CRIMP DIE
 - DO NOT PROBE, TEST OR OTHERWISE CONTACT THE INTERIOR REGION (THE SPRING OR ANY MOVING PART) OF THIS TERMINAL. SEVERE DAMAGE CAN OCCUR, COMPROMISING THE PERFORMANCE OF THE ELECTRICAL INTERFACE.
 - PLATING TYPE:
1. REFLOW TIN 1.9-3.3 MICROMETERS THICK WITH A COPPER UNDERPLATE 0.5 MICROMETER TO 1.0 MICROMETER THICK.
11. HOT DIP TIN/SILVER 1.2-3.5 MICROMETERS THICK
- PLATING TYPE INFORMATION SHOWN ABOVE IS REFERENCE ONLY, PLATING REQUIREMENTS ARE CONTAINED IN APPLICABLE MATERIAL SPECIFICATION.

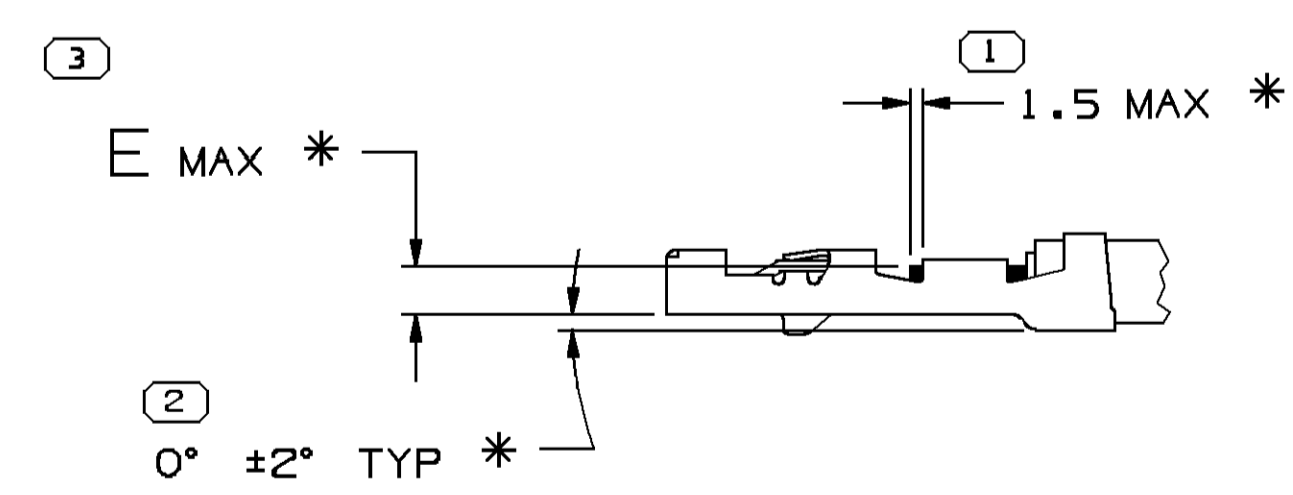

TYPE 101

TERMINAL AND CABLE ALIGNMENT
SCALE 5:1

PART NO	REV	N/P	PREFERRED MAT'L SIZE	ALTERNATIVE MAT'L SIZE	MAT'L DESCRIPTION	SIZE (MM ²)	ID	DIA	TYPE	B _{1±0.2}	(L)	E _{MAX}	CONTACT AREA PLATING TYPE (SEE NOTE 5)	CRIMP AREA PLATING TYPE (SEE NOTE 5)	RESTRICTED USAGE
13734673	01	AG	0.3 X 26.71	0.3 X 27.38	COPPER ALLOY	0.22 - 0.13	25	1.1 - 0.81	102	1.8	18.9	1.8	I	I	-
13723823	01	AG	0.3 X 26.71	0.3 X 27.38	BE COPPER ALLOY	1.5 - 3	13	3.2 - 2.2	101	3.75	18.9	2.45	I	I	-
15345940	01	AF	-	0.3 X 27.38	COPPER ALLOY	1.5 - 3	13	3.2 - 2.2	101	3.75	18.9	2.45	II	II	-
15427675	01	AL	0.3 X 26.71	0.3 X 27.38	COPPER ALLOY	0.35 - 0.5	21	1.1 - 1.3	101	2.1	18.9	2.45	I	I	-
15336198	B11	-	0.3 X 26.71	0.3 X 27.38	COPPER ALLOY	1.25 - 2.5	14	3 - 2.05	101	3.7	18.9	2.45	I	I	-
12191135	F11	-	0.3 X 26.71	0.3 X 27.38	COPPER ALLOY	(2) 0.8	218	1.7 - 2.05	101	3.8	19.2	2.45	I	I	-
12191134	E11	-	0.3 X 26.71	0.3 X 27.38	COPPER ALLOY	(2) 0.5	220	1.85 - 1.4	101	3.3	19.2	2.45	I	I	-
12191133	E12	-	0.3 X 26.71	0.3 X 27.38	COPPER ALLOY	(2) 0.35	222	1.65 - 1.2	101	2.7	19.2	2.45	I	I	-
15304713	E12	-	0.3 X 26.71	0.3 X 27.38	COPPER ALLOY	4 - 5	10	3.9 - 3.4	101	4.8	19.2	2.45	I	I	RESTRICTED
15304712	E14	-	0.3 X 26.71	0.3 X 27.38	COPPER ALLOY	1.5 - 3	13	3.2 - 2.2	101	3.75	18.9	2.45	I	I	-
15304711	E14	-	0.3 X 26.71	0.3 X 27.38	COPPER ALLOY	0.75 - 1	17	2.25 - 1.7	101	2.65	18.9	2.45	I	I	-
15304710	E15	-	0.3 X 26.71	0.3 X 27.38	COPPER ALLOY	0.35 - 0.5	21	1.85 - 1.2	101	2.1	18.9	2.45	I	I	-

LINE DRAWN THROUGH A PART NUMBER INDICATES THAT PHYSICAL PARTS ARE NOT AVAILABLE FOR ORDERING.

PART NUMBERS THAT DO NOT HAVE A LINE PRESENT INDICATE THAT PHYSICAL PARTS ARE AVAILABLE FOR ORDERING.

CONTACT DELPHI SALES TO ASSURE AVAILABILITY OF PARTS.

DWG TYPE: PART DRAWING

STYLE: D

VOLUME (CPI): DISTR CODE: D

UNLESS OTHERWISE SPECIFIED THIS DOCUMENT IS IN ACCORDANCE WITH ASME Y14.5M-1994 AS MODIFIED BY THE 0M GLOBAL DIMENSIONING AND TOLERANCING ADDENDUM - 1997. ALL GEOMETRIC TOLERANCES AND RELATED DATUMS APPLY RFS. RULE #1 (PERFECT FORM AT ALL TIMES) DOES NOT APPLY WHEN RELATIONSHIP BETWEEN FEATURES IS ESTABLISHED BY ORIENTATION OR LOCATION TOLERANCES. SEPARATE POSITION CALLOUTS MAY BE GAGED SEPARATELY, REGARDLESS OF DATUM REFERENCE. ALL DIMENSIONS ARE IN MILLIMETERS.

REFERENCE:

(11) PROCESS SENSITIVE DIMENSION

DIMENSIONS ENCLOSED IN () INDICATE REFERENCE DIMENSIONS AND NO TOLERANCE LIMITS ARE ESTABLISHED

DIMENSIONAL RANGE (MM) CHART 6

FROM	0	> 12
TO	12	> 12

TOLERANCE UNLESS OTHERWISE SPECIFIED:

±0.15	±0.3
ANGULAR TOLERANCE ±2°	

THIRD ANGLE PROJECTION

DO NOT SCALE

USE MATH DATA

NX

DELPHI
DELPHI PACKARD ELECTRICAL/ELECTRONIC ARCHITECTURE
WARREN, OH
COPYRIGHT 1996 DELPHI CORPORATION AND/OR ITS AFFILIATES. ALL RIGHTS RESERVED.
REVISION 2012
THIS DRAWING IS THE PROPERTY OF DELPHI CORPORATION. THE REPRODUCTION, DISTRIBUTION AND UTILIZATION OF THIS DOCUMENT OR ITS RELATED CAD DATA, AS WELL AS COMMUNICATION OF ANY CONTENT TO OTHERS, WITHOUT EXPRESS AUTHORIZATION IS PROHIBITED.

DR	DATE
APVD1 N. VERGARA	06FE96
APVD2 T. STEELE	08JN96
APVD3 S.C. HSIEH	28JN96
APVD4	
APVD5	

SUBSTANCES OF CONCERN AND RECYCLED CONTENT PER DELPHI 10949001

MATERIAL SEE CHART

DRAWING NAME: TAXI TERM F 0T 280

DRAWING NUMBER: 15304709

SIZE	SCALE	FRAME NO	SHEET NO	STG	REV	N/P
A1	10:1	1 OF 1	1 OF 1	R	32	-

X-ON Electronics

Largest Supplier of Electrical and Electronic Components

Click to view similar products for [Automotive Connectors](#) category:

Click to view products by [APTIV](#) manufacturer:

Other Similar products are found below :

[003-018-000](#) [60403001](#) [60993906-B](#) [M902-2131](#) [M902-2161](#) [72.330.1035.1](#) [73.353.4028.0](#) [F119300-B](#) [F166900](#) [F258300-B](#) [F358300-B](#)
[F407400](#) [F444110](#) [F487000](#) [F509500B-B](#) [827153-1](#) [8N1515-32-24P](#) [9-1326729-8](#) [925474-1](#) [928905-1](#) [964562-4](#) [968782-1](#) [GT17SA-8DS-](#)
[HU](#) [98891-1012](#) [98947-1016](#) [12004475-L](#) [12010290](#) [12010309-B](#) [12015454](#) [12020219-B](#) [12020308](#) [12041318-B](#) [12052225-L](#) [12052466](#)
[12059125](#) [12064869](#) [12004327-B](#) [12010503-B](#) [12015308](#) [12015384](#) [12015909](#) [1-21030-1](#) [12041254](#) [12041318](#) [12047946-B](#) [12047957](#)
[12047957-L](#) [12059473](#) [12066261](#) [12110546](#)