

SYMBOL DEFINITION		MISSING SYMBOLS	
A DIMENSION WITHOUT AN INSPECTION REPORT SYMBOL DOES NOT REQUIRE INSPECTION. IT MAY BE CONTROLLED ON THE INDIVIDUAL COMPONENT DRAWING.	TOTAL NO OF INSPECTIONS REQUIRED	NO MISSING SYMBOL NUMBER	
	19		
	LAST NO. USED		
	18		

DWS STATUS		REV		DATE		ZONE		REVISION HISTORY		AUTH		DR		APVD	
30JL02	R	07	-	-	-	-	-	CLEARED REV COL & ALL PARTS - UPDATED PDM ATTRIBUTES	226419	JHN	FRB	TTP			
30JA03	R	08	-	-	-	-	-	ALL PARTS - UPDATED PDM ATTRIBUTES	235188	CJP	CJP	CSD			
05FE03	R	09	-	-	-	-	-	REVISED NOTE SYMBOL 345 IN TOD	236543	LMB	LMB	SCH			
16JL03	R	10	-	-	-	-	-	15392777 - CORRECTED PLATING TYPE TO 102	243460	JMR	JMR	JMN			
22JL03	R	11	-	-	-	-	-	ADDED DIM 2.7580.1 FOR SPRING BACK	243779	RH	RH	SCH			
14AP04	R	12	-	-	-	-	-	15491972 - RELEASED	253968	TLD	TLD	MP			
24SE04	R	13	-	-	-	-	-	ALL PARTS - ADDED STAMP DIE I.D.	259075	MDH	AUG	MKM			
09MY05	R	14	-	-	-	-	-	13528779 - RELEASED	267849	JTV	FKV	LJM			
16MY05	R	15	-	-	-	-	-	13528779 - MAT'L SPEC WAS M-3669	268220	JOA	JVM	LJM			
30MY05	R	16	-	-	-	-	-	15326004 - MATERIAL SPEC WAS M-3669	268590	BLG	JMV	LJM			
15AU05	R	17	-	-	-	-	-	15326004 - UPDATED PDM ATTRIBUTES	271195	JBD	FRG	MJC			
30MY06	R	18	-	-	-	-	-	15366684, 15392777, 15401195 & 15491972 - UPDATED PDM ATTRIBUTES	281105	TLD	TLD	MJC			
03DE07	R	19	-	-	-	-	-	13528779 & 15326004 - MATERIAL SPEC WAS M3669A23	403115	RH	RH	RWR			
06OC08	R	20	-	-	-	-	-	13722256 & 13722259 - WAS ON SHT "1"	406320	ACG	FKV	EJB			
16OC08	R	21	-	-	-	-	-	13737693 - RELEASED 13722256 & 13722259 - MAT'L SPEC WAS M6053MNB C42500 EX HD	406450	EAJ	FKV	EJB			
27OC08	R	22	-	-	-	-	-	13528779, 15326004, 15366684, 15392777, 15401195 & 15491972 - UPDATED MATERIAL CALLOUT	406615	VMR	HAD	VMR			
25FE09	R	23	-	-	-	-	-	13722256 & 13722259 - WERE TYPE 102	407450	EPS	FKV	GER			
24AP09	R	24	-	-	-	-	-	15491972, 15392777, 15401195 & 15366684 - UPDATED PDM ATTRIBUTES & 13528779 WAS TYPE 102	407887	HRS	JVM	VMR			
29OC09	R	25	-	-	-	-	-	13737693 - INACTIVE	409340	JTZ	FKV	GER			
29MR10	R	26	-	-	-	-	-	ALL ACTIVE PARTS - UPDATED PDM ATTRIBUTES	410350	JTZ	JTZ	MAC			
18AU10	R	27	-	-	-	-	-	ALL ACTIVE PARTS - UPDATED MAT'L DESC, ADDED "CONTACT TYPE" COLUMN, "CRIMP TYPE" COLUMN & "PLATING TYPE" NOTE	411650	HRS	HRS	VMR			
24AU10	R	28	-	-	-	-	-	15326004 - "CONTACT AREA" WAS NOTE IV & "CRIMP AREA" WAS NOTE III	411755	HRS	HRS	VMR			
29SE10	R	29	-	-	-	-	-	ALL ACTIVE PARTS - UPDATED "PLATING TYPE" NOTE	412115	JRL	JRL	VMR			
11NO10	R	30	-	-	-	-	-	ALL ACTIVE PARTS - DIM 2.75 ± 0.1 WAS 2.75 ± 0.05	412569	LHT	LHT	LHT			
19NO10	R	31	-	-	-	-	-	13722256 & 13722259 - MAT'L SIZE WAS 0.3 X 25.21	412482	MAL	MAL	VMR			
19DE11	R	32	-	-	-	-	-	ALL ACTIVE PARTS - ADDED PREFERRED MAT'L SIZE COLUMN ON TAXI CHART AND UPDATED PDM ATTRIBUTES	416538	JAR	JAR	OAF			
31JA12	R	33	-	-	-	-	-	15326004 - REVISED MAT'L CALLOUT TO GENERIC MATERIAL	416912	MAL	MAL	OAF			
15OC14	R	34	-	-	-	-	-	13722256 & 13722259 - REVISED NOTE V ABOUT "TARNISH INFO" IN PLATING TYPE	427926	ABH	JVM	JSW			

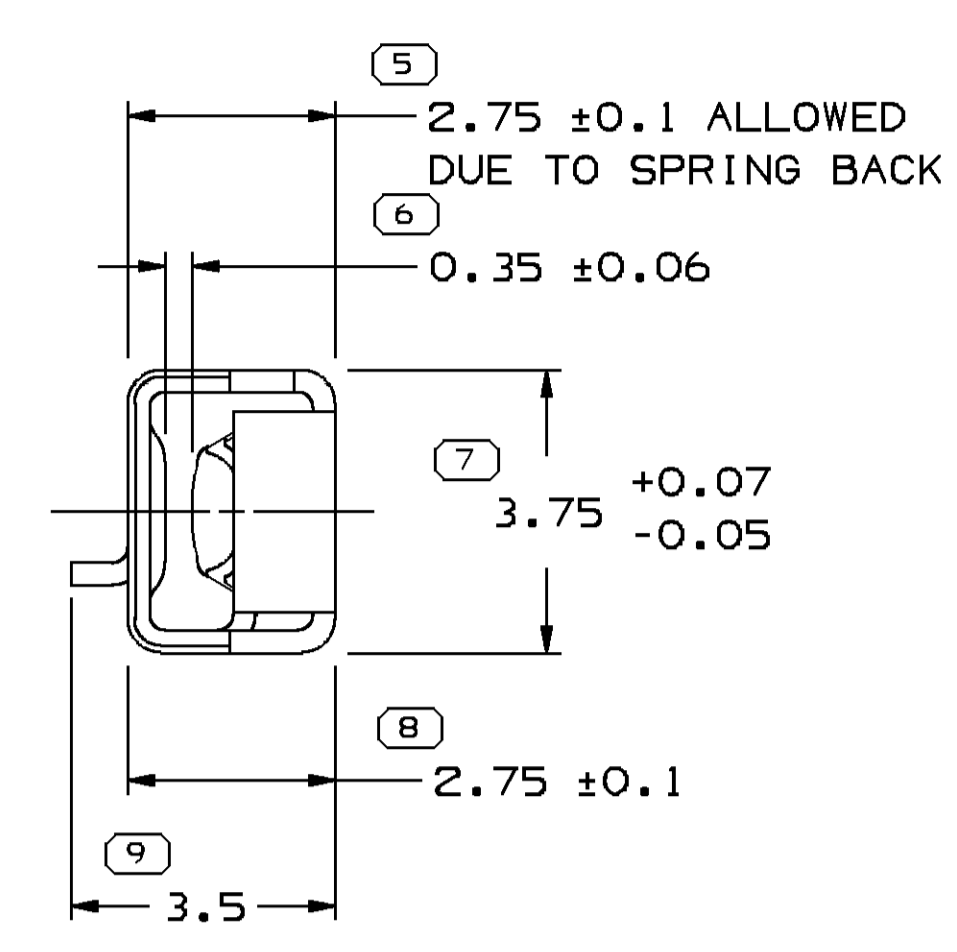

STAMP DIE I.D. "PXX" IN THIS AREA (0.6) CHARACTERS XX DESIGNATES DIE NUMBER, LOCATION IS APPROXIMATE.

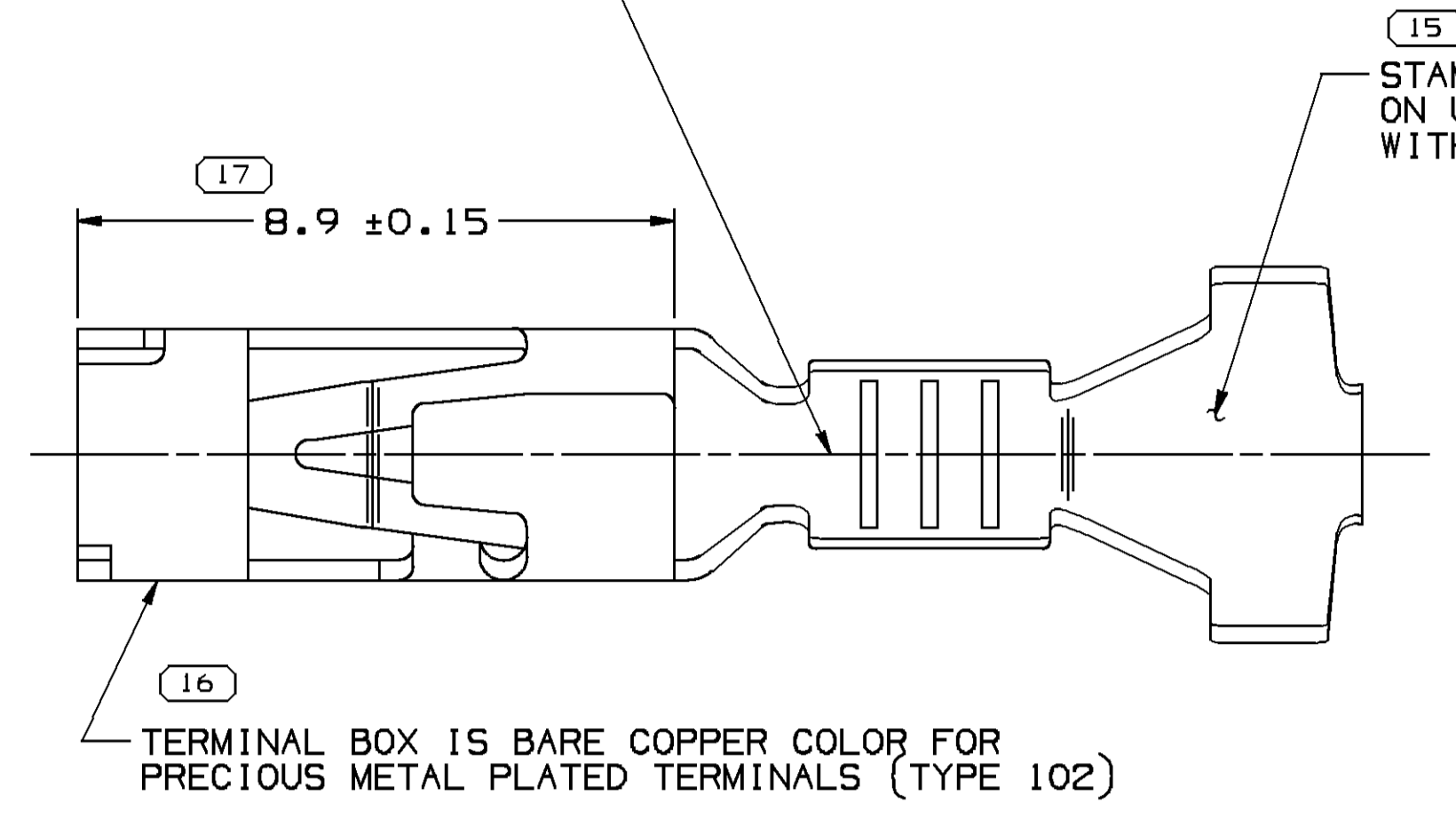

STAMP CABLE I.D. (SEE CHART) ON UNDERSIDE IN THIS AREA WITH 0.8 MIN HIGH NUMBERS

TERMINAL BOX IS BARE COPPER COLOR FOR PRECIOUS METAL PLATED TERMINALS (TYPE 102)

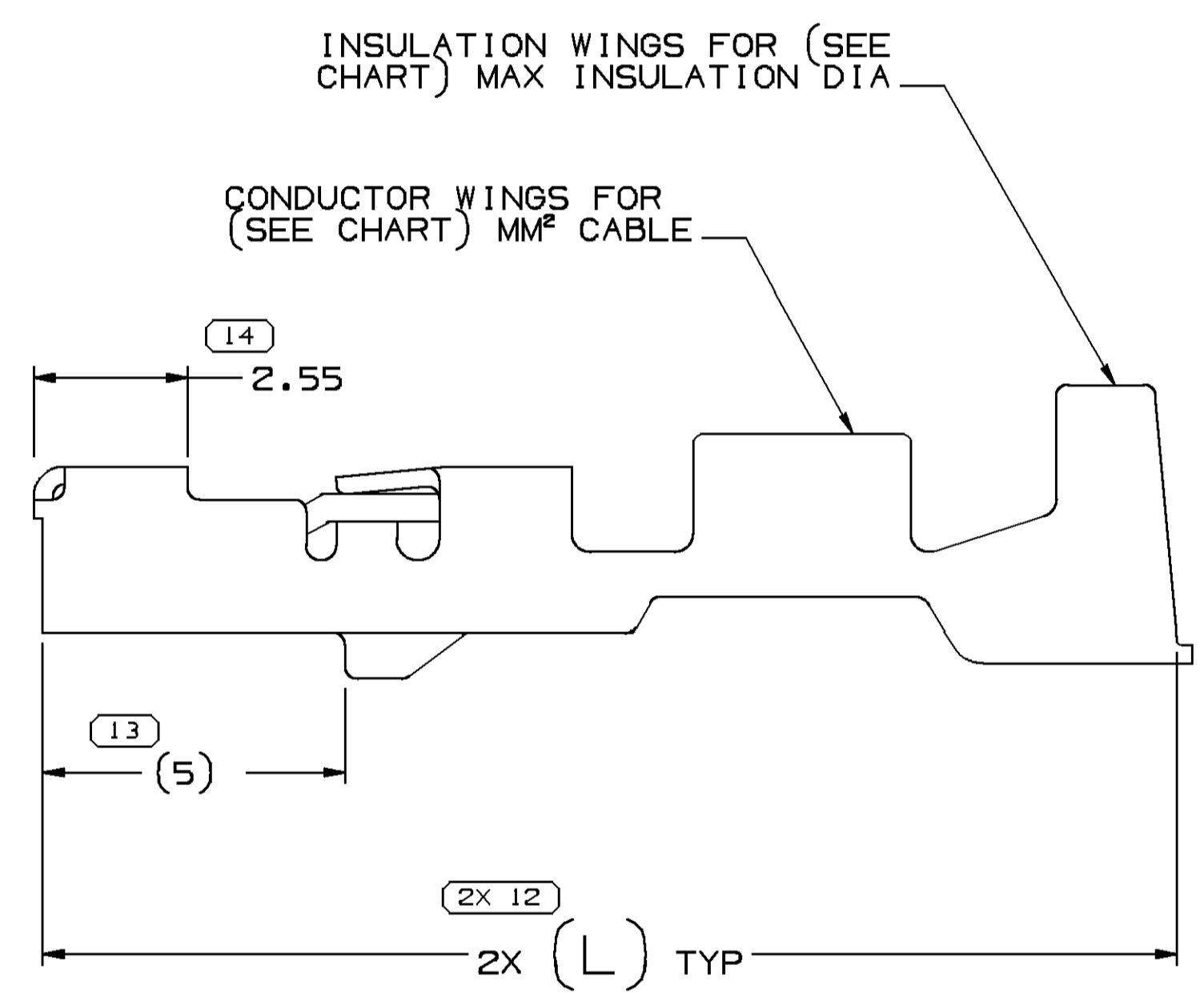
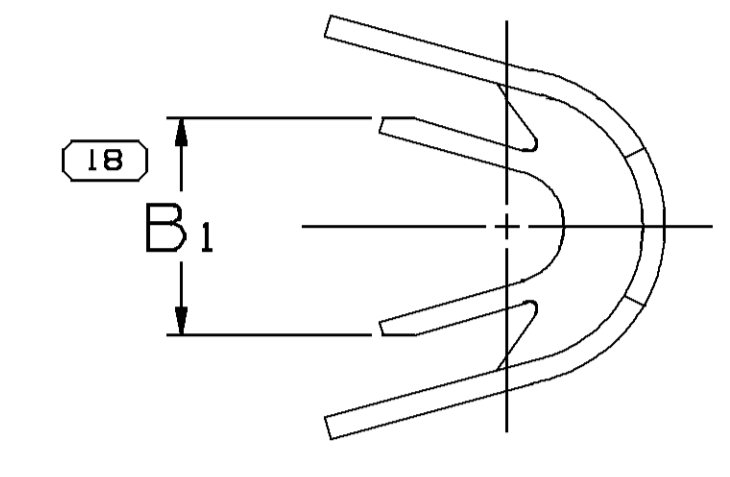

INSULATION WINGS FOR (SEE CHART) MAX INSULATION DIA

CONDUCTOR WINGS FOR (SEE CHART) MMF CABLE

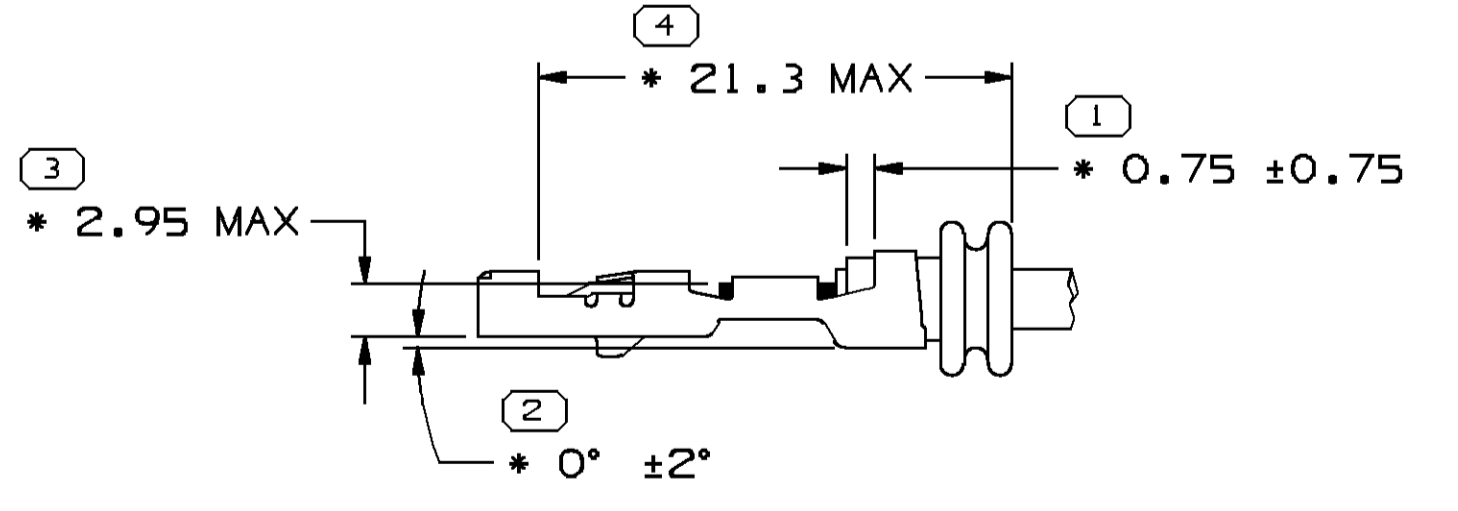

2 RIB SEAL POSITION REF AND TERMINAL & CABLE ALIGNMENT SCALE 5:1

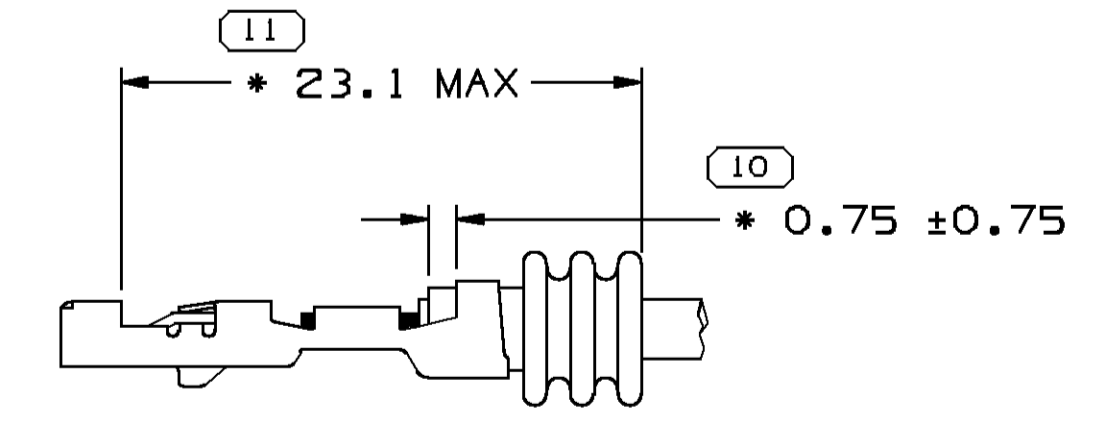

3 RIB SEAL POSITION REF SCALE 5:1

NOTES

- UNLESS OTHERWISE SPECIFIED AND/OR INDICATED:
    - DIMENSIONS ARE TO FACE OF VIEW SHOWN AND AUTOMATICALLY ROUNDED BY COMPUTER FOR INSPECTION (SEE MATH MODEL FOR PRECISE DIMENSIONS). FOR ALL OTHER DIMENSIONS NOT SHOWN BUT REQUIRED FOR TOOL BUILD, SEE MATH MODEL FOR PRECISE TOOL PATH DATA.
  - FOR PRECIOUS METAL PLATED TERMINALS (TYPE 102), MATING TERMINAL MUST HAVE A PRECIOUS METAL (GOLD TO GOLD) CONTACT INTERFACE.
  - "\*" DENOTES DIMENSIONS MADE AT CUT-OFF AND CRIMP DIE.
  - DO NOT PROBE, TEST OR OTHERWISE CONTACT THE INTERIOR REGION (THE SPRING OR ANY MOVING PART) OF THIS TERMINAL. SEVERE DAMAGE CAN OCCUR, COMPROMISING THE PERFORMANCE OF THE ELECTRICAL INTERFACE.
  - PLATING TYPE:
    - I. MATE TIN ELECTROPLATE 1.9 - 7.0 MICROMETERS THICK WITH A NICKEL UNDER PLATE 0.13 - 0.25 MICROMETERS THICK
    - II. REFLOW TIN 1.9 - 3.3 MICROMETER THICK WITH A COPPER UNDERPLATE 0.5 MICROMETER TO 1.0 MICROMETER THICK.
    - III. MATE TIN ELECTROPLATE 1.9 - 7.0 MICROMETERS THICK.
    - IV. 1.27 MICROMETERS DIFFUSED GOLD PALLADIUM/SILVER ALLOY INLAY OVER 1.27 MICROMETERS THICK NICKEL UNDERLAY.
    - V. SILVER 3.5 - 6.0 MICROMETERS THICK OVER 0.13 - 0.25 MICROMETERS THICK NICKEL UNDERPLATE.
  - FOR TERMINALS PACKAGED & STORED IN THE APPROVED MANNER, TARNISH ON SILVER PLATED SURFACES WILL NOT AFFECT THE PERFORMANCE OF THE PART.
- PLATING TYPE INFORMATION SHOWN ABOVE IS REFERENCE ONLY, PLATING REQUIREMENTS ARE CONTAINED IN APPLICABLE MATERIAL SPECIFICATION.

PART NO	REV	N/P	PREFERRED MAT'L SIZE PLATED	ALTERNATIVE MAT'L SIZE	MAT'L DESCRIPTION	SIZE MMF	I.D. CABLE	DIA	TYPE	B <sub>1</sub> ±0.2 (L)	TYPICAL CABLE SEAL	TYPICAL SEALING CAVITY CONFIG	CONTACT AREA PLATING TYPE (SEE NOTE 5)	CRIMP AREA PLATING TYPE (SEE NOTE 5)
13737693	01	AA	0.3 X 26.71	0.3 X 26.71		4 - 5	10	3.9	101	4.8	18.9	12191235 OR EQUIVALENT	5.8 DIA ROUND	
13722259	01	AL	0.3 X 26.71	0.3 X 27.38	AG PLATED COPPER ALLOY	0.75-1	17	2.25-1.7	101	2.65	18.9	15366066 OR EQUIVALENT	5.8 DIA ROUND	V
13722256	01	AL	0.3 X 26.71	0.3 X 27.38	AG PLATED COPPER ALLOY	2 - 3	13	3.2 - 2.5	101	3.75	18.9	15366067 OR EQUIVALENT	5.8 DIA ROUND	V
13528779	01	AK	0.3 X 26.71	0.3 X 27.38	SN PLATED COPPER ALLOY	2 - 3	13	3.2 - 2.5	101	3.75	18.9	15366067 OR EQUIVALENT	5.8 DIA ROUND	II
15491972	01	AK	0.3 X 26.71	0.3 X 27.38	AU PLATED COPPER ALLOY	0.75-1	17	2.25-1.7	102	2.65	18.9	15366066 OR EQUIVALENT	5.8 DIA ROUND	III
15392777	01	AT	0.3 X 26.71	0.3 X 27.38	AU PLATED COPPER ALLOY	4 - 5	10	3.9 - 3.4	102	4.8	18.9	12191235 OR EQUIVALENT	5.8 DIA ROUND	IV
15401195	01	AT	0.3 X 26.71	0.3 X 27.38	AU PLATED COPPER ALLOY	0.35-0.5	21	1.85-1.2	102	2.1	18.9	15366065 OR EQUIVALENT	5.8 DIA ROUND	IV
15366684	01	AV	0.3 X 26.71	0.3 X 27.38	AU PLATED COPPER ALLOY	2 - 3	13	3.2 - 2.5	102	3.75	18.9	15366067 OR EQUIVALENT	5.8 DIA ROUND	IV
15326004	D18	-	0.3 X 26.71	0.3 X 27.38	SN PLATED COPPER ALLOY	4 - 5	10	3.9 - 3.4	101	4.8	18.9	12191235 OR EQUIVALENT	5.8 DIA ROUND	II

FROM	TO	CHART CD
0	12	
10	15	
15	20	
20	25	
25	30	
30	35	
35	40	
40	45	
45	50	
50	55	
55	60	
60	65	
65	70	
70	75	
75	80	
80	85	
85	90	
90	95	
95	100	

**DELPHI**  
DELPHI PACKARD ELECTRICAL/ELECTRONIC ARCHITECTURE  
WARREN, OH  
COPYRIGHT 1997 DELPHI CORPORATION AND/OR ITS AFFILIATES. ALL RIGHTS RESERVED.  
THIS DRAWING IS THE PROPERTY OF DELPHI CORPORATION AND CONTAINS DELPHI CONFIDENTIAL INFORMATION. THE REPRODUCTION, DISTRIBUTION AND UTILIZATION OF THIS DOCUMENT OR ITS CONTENTS OR DATA, AS WELL AS COMMUNICATION OF ANY CONTENT TO OTHERS, WITHOUT EXPRESS AUTHORIZATION, IS PROHIBITED.

DATE: \_\_\_\_\_  
OR: \_\_\_\_\_  
APVD1: H. CASTRILLON  
APVD2: R. RAMOS S.  
APVD3: B. EDWARDS  
APVD4: \_\_\_\_\_  
APVD5: \_\_\_\_\_

SUBSTANCES OF CONCERN AND RECYCLED CONTENT PER DELPHI (1944901)

DRAWING NAME: TAXI TERM F GT 280 SEALED  
DRAWING NUMBER: 15304714  
SIZE: A0  
SCALE: 10:1  
FRAME NO: 1 OF 1  
SHEET NO: 2 OF 2  
STG: R  
REV: 34

## X-ON Electronics

Largest Supplier of Electrical and Electronic Components

*Click to view similar products for [Automotive Connectors](#) category:*

*Click to view products by [APTIV](#) manufacturer:*

Other Similar products are found below :

[003-018-000](#) [60403001](#) [60993906-B](#) [629515004020001](#) [M902-2131](#) [M902-2161](#) [72.330.1035.1](#) [73.353.4028.0](#) [F119300-B](#) [F166900](#)  
[F258300-B](#) [F358300-B](#) [F407400](#) [F444110](#) [F487000](#) [F509500B-B](#) [827153-1](#) [8N1515-32-24P](#) [9-1326729-8](#) [925474-1](#) [928905-1](#) [964562-4](#)  
[968782-1](#) [GT17SA-8DS-HU](#) [98891-1012](#) [98947-1016](#) [12004475-L](#) [12010290](#) [12010309-B](#) [12015454](#) [12020219-B](#) [12020308](#) [12041318-B](#)  
[12052225-L](#) [12052466](#) [12059125](#) [12064869](#) [12004327-B](#) [12010503-B](#) [12015308](#) [12015384](#) [12015909](#) [1-21030-1](#) [12041254](#) [12041318](#)  
[12047946-B](#) [12047957](#) [12047957-L](#) [12059473](#) [12066261](#)