

SYMBOL DEFINITION		MISSING SYMBOLS	
A DIMENSION WITHOUT AN INSPECTION REPORT SYMBOL DOES NOT REQUIRE INSPECTION. IT MAY BE CONTROLLED ON THE INDIVIDUAL COMPONENT DRAWING.	TOTAL NO OF INSPECTIONS REQUIRED	NO MISSING SYMBOL NUMBER	
	69		
	67		

DWO STATUS				REVISION HISTORY				AUTH				
DATE	STG	REV	N/P	CHG	ZONE				DR	APVD	APVD	
05JAO1	R	01	-	-	-				205060	JTD	EAR	RC
08FE01	R	02	-	-	-				206542	EAR	EAR	RC
08MR01	R	03	-	-	-				207529	EAR	EAR	RC
07MR02	R	04	-	-	-				219675	JGR	EOV	AL
21MR02	R	05	-	-	-				222796	EOV	EOV	AL
11MY04	R	06	-	-	-				255159	JTV	FKV	MR
04AU04	R	07	-	-	-				257695	LMB	LMB	MR
31JA05	R	08	-	-	-				262630	MM	MM	MR
08AU05	R	09	-	-	-				270872	CJP	CJP	MR

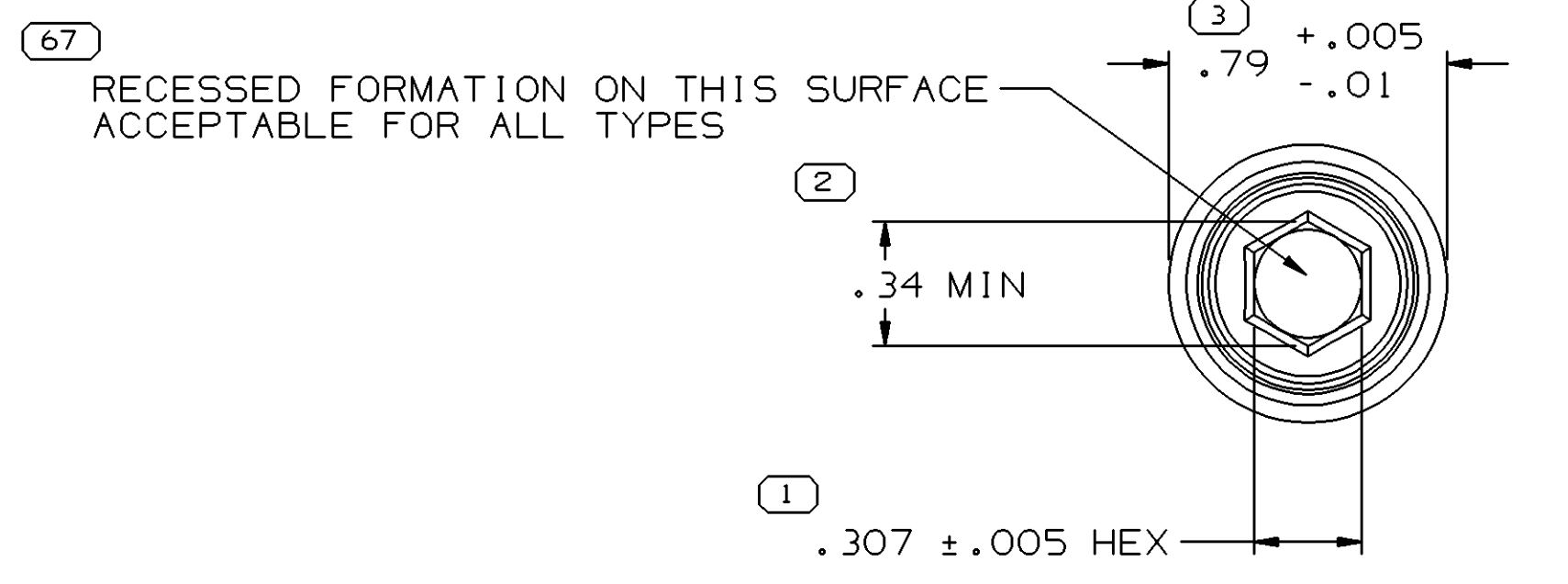

(SAME FOR 201 & 202 HEAD TYPES)

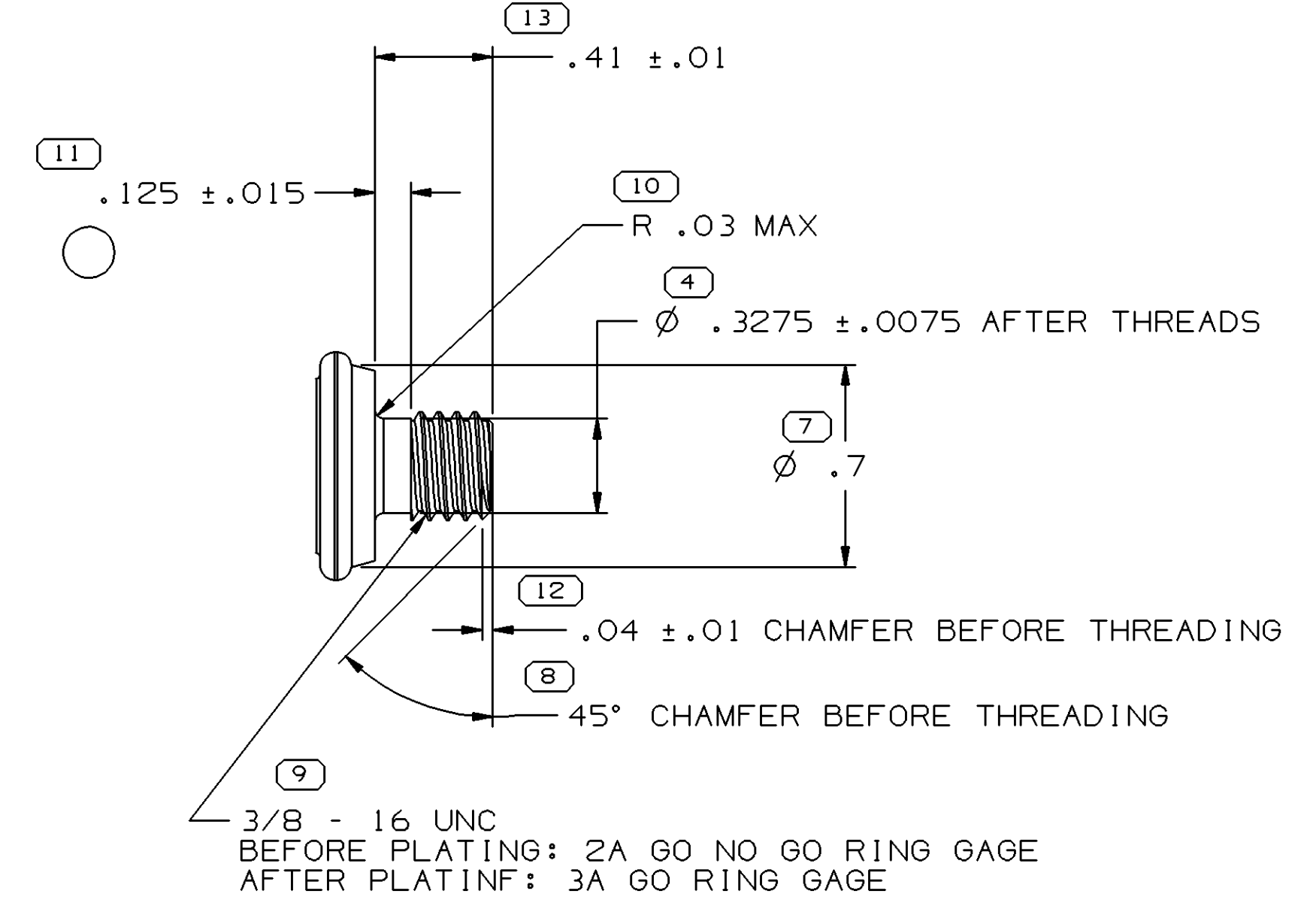
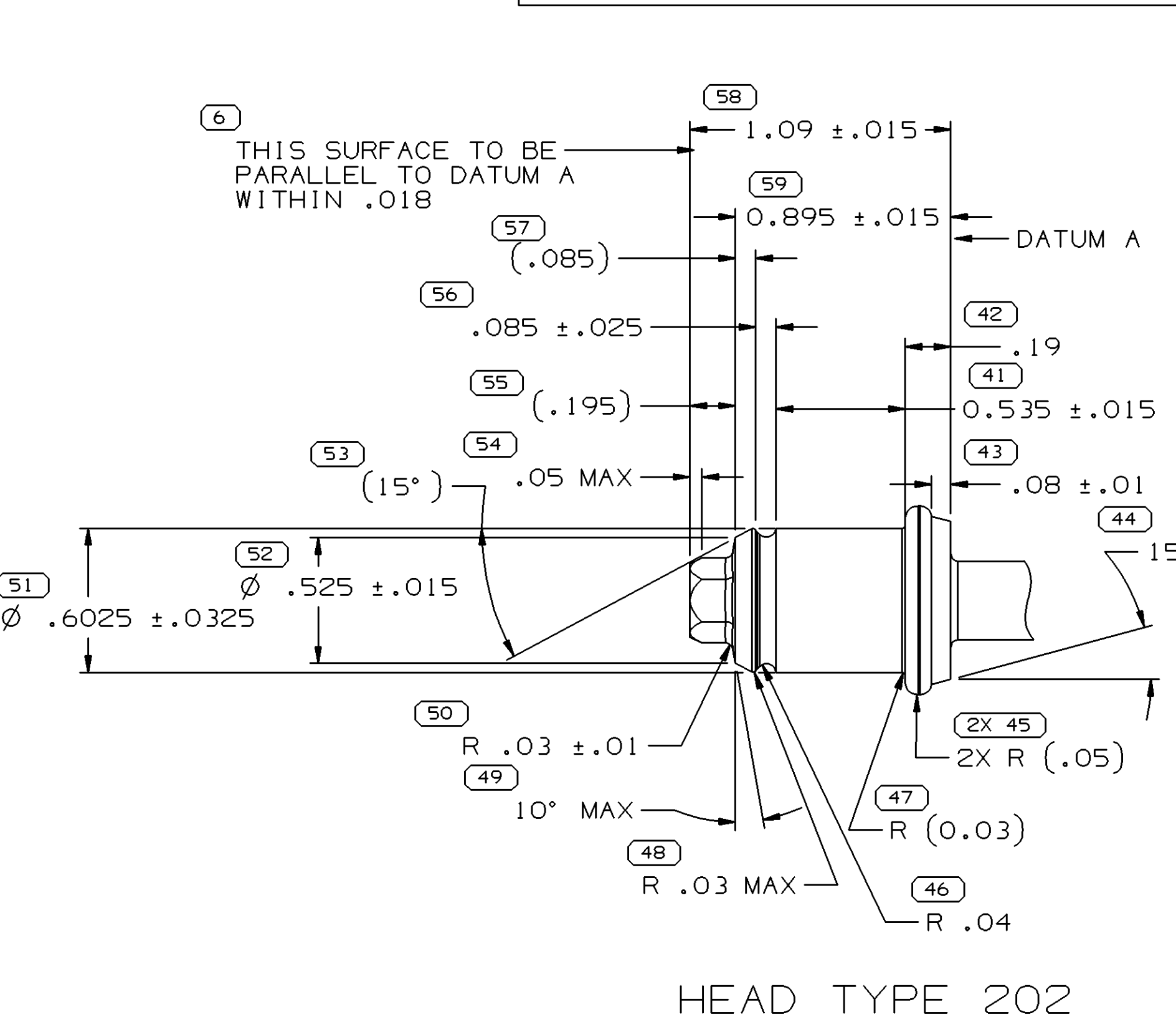
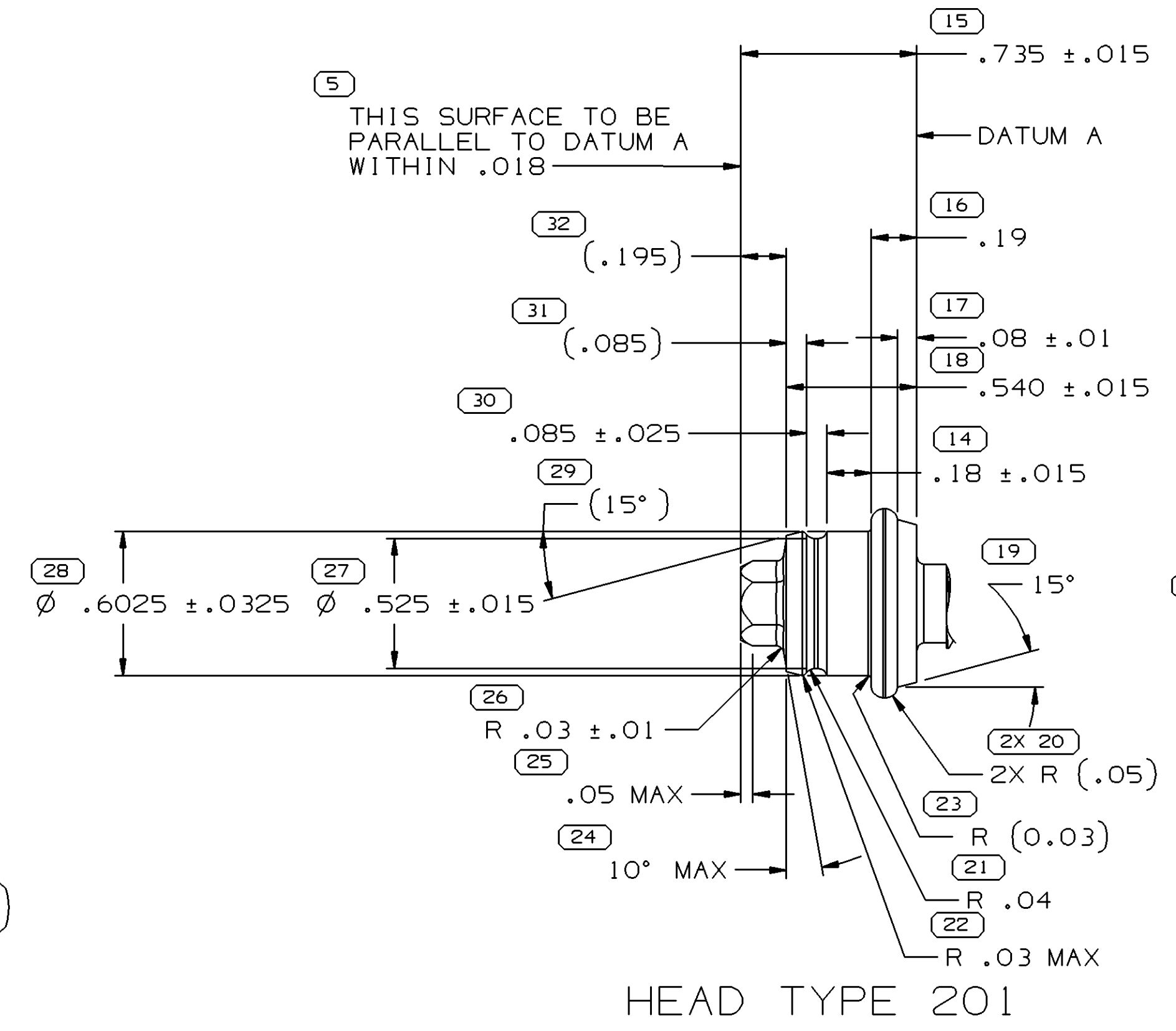

SHAFT TYPE 101

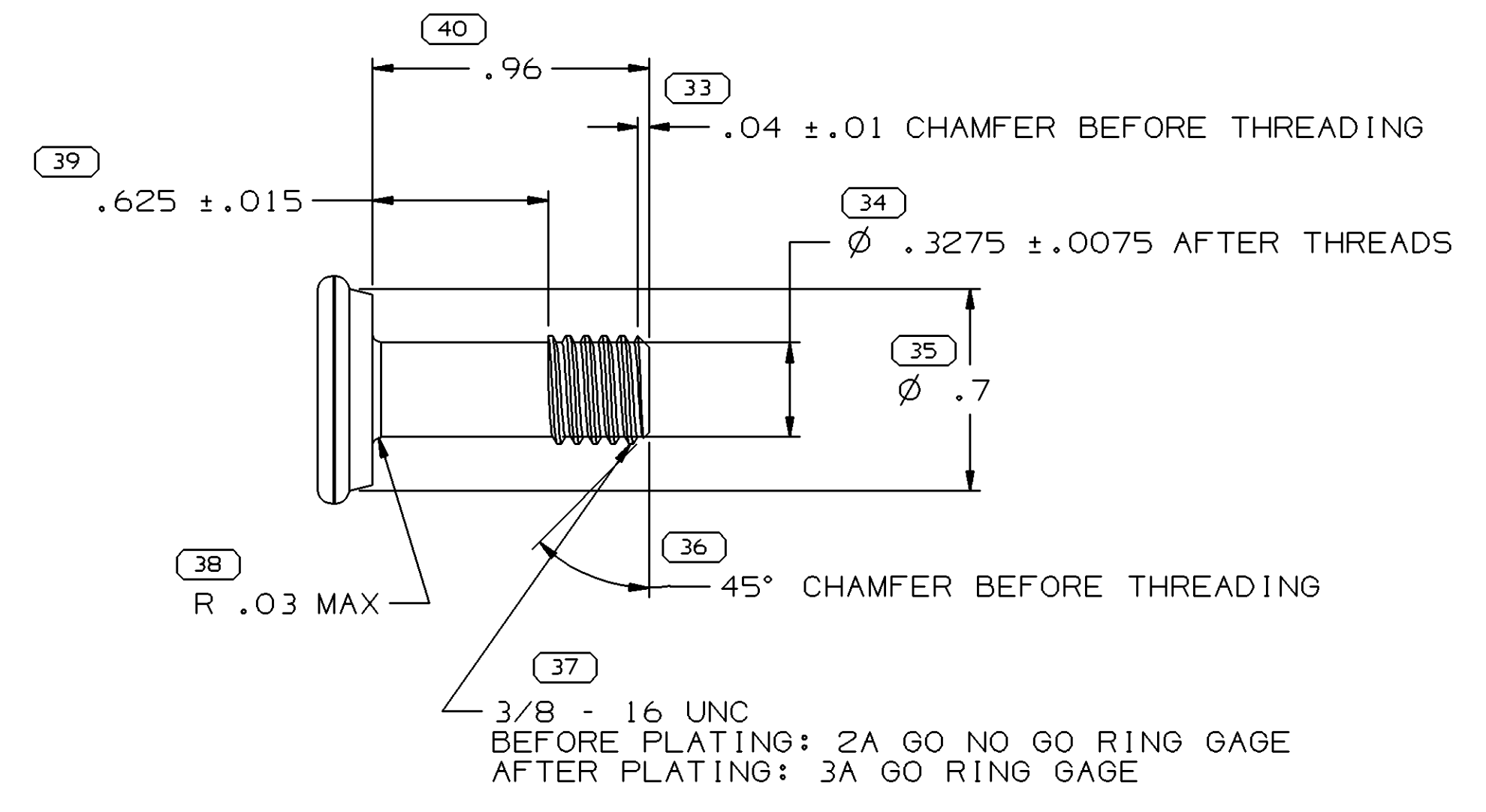

SHAFT TYPE 102

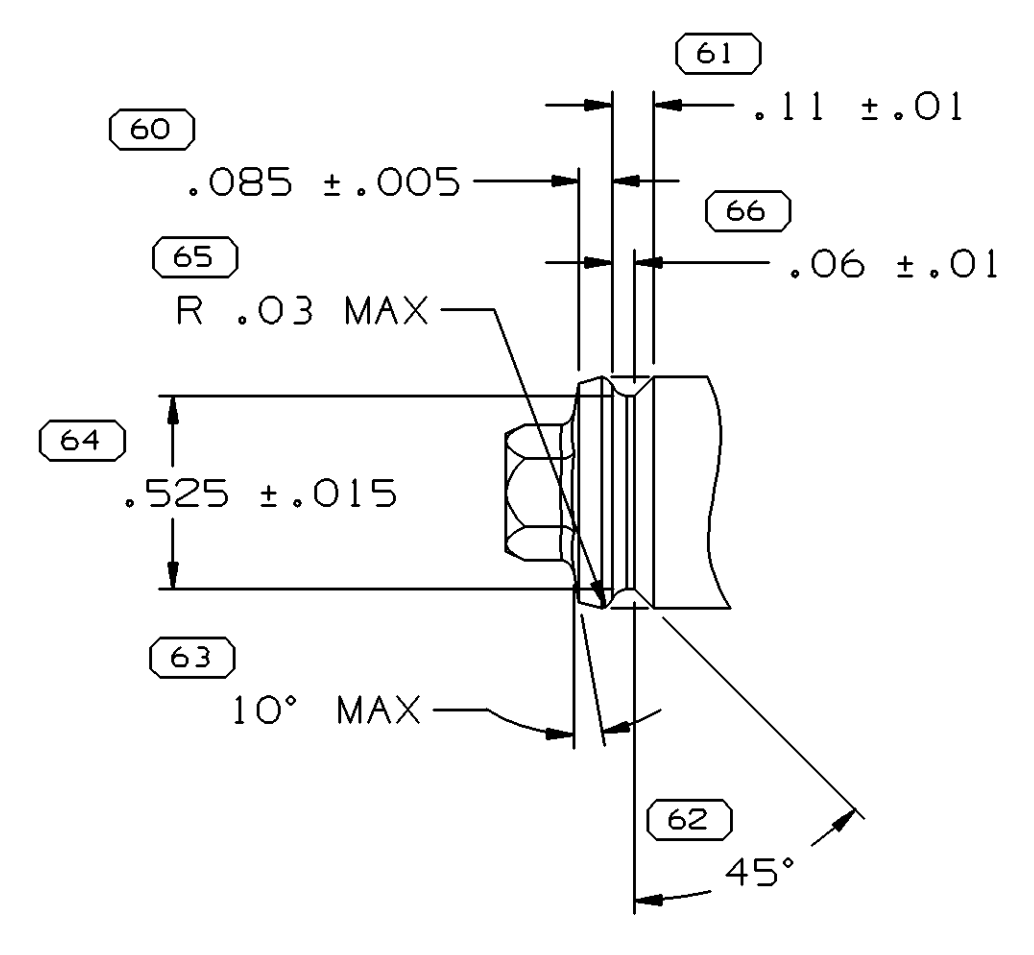

OPTIONAL CONSTRUCTION (FOR SHAVED GROOVE)

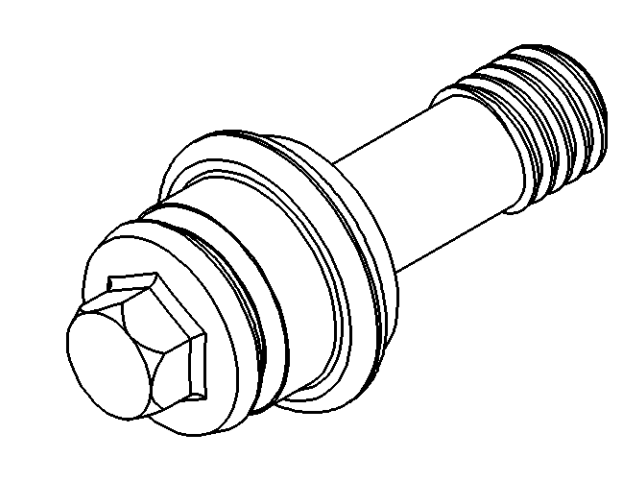

15492510

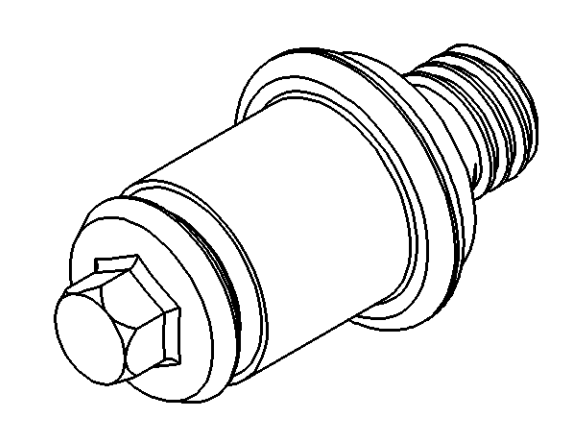

15492589

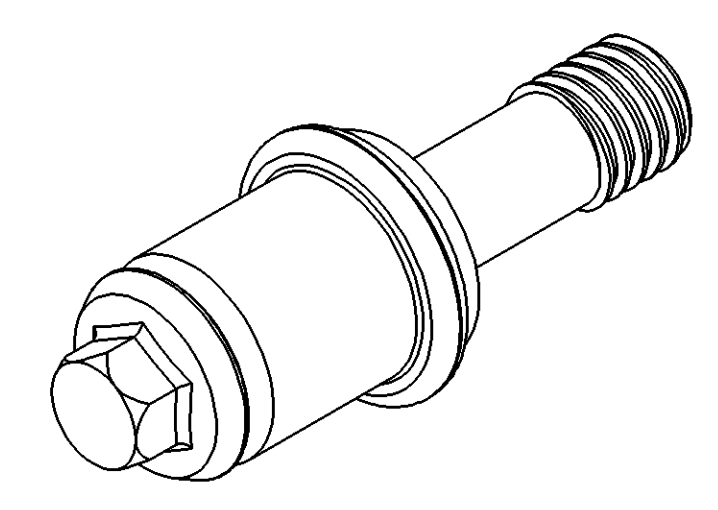

15492573

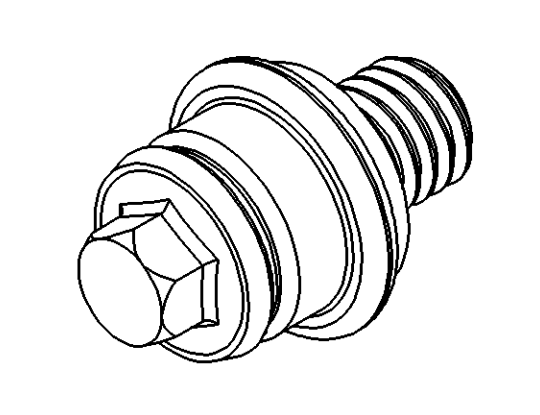

08917513  
15492508  
08917443

PROCESS NOTES

1. PLATED PER DX551263-P.
2. A WATER SOLUBLE LUBRICATING WAX TO BE APPLIED AFTER PLATING AND SEALER PROCESSES.
3. FINISH MUST WITHSTAND 200HRS MINIMUM BEFORE CORROSION IN NEUTRAL SALT FOG.
4. ZINC PLATE YELLOW CHROMATE PER POS-1065 WITH "PAVCO" SEALER. MINIMUM THICKNESS 350 MICRO INCHES.

NOTES

1. UNLESS OTHERWISE SPECIFIED AND/OR INDICATED: DIMENSIONS ARE TO FACE OF VIEW SHOWN AND AUTOMATICALLY ROUNDED BY COMPUTER FOR INSPECTION (SEE MATH MODEL FOR PRECISE DIMENSIONS). FOR ALL OTHER DIMENSIONS NOT SHOWN BUT REQUIRED FOR TOOL BUILD, SEE MATH MODEL FOR PRECISE TOOL PATH DATA.
2. TORQUE OF BOLT MUST NOT EXCEED 35 IN-LB. WITH THE USE OF A MAX. (AFTER PLATE) RING GAUGE OF .3344 PITCH DIAMETER.
3. HEX HEAD TO ACCEPT 5/16 DRIVE SIZE.
4. .3275 DIA & .6025 DIA MUST BE CONCENTRIC TO .790 DIA WITHIN ±.005 FOR TYPE 201 AND 202 HEADS
5. DIM 28, 52, & 64 REFER TO DIAMETER OF THE SHAVED GROOVE.

PART NO	STATUS	REV	N/P	SHAFT TYPES	HEAD TYPES	PROCESS NOTES	REPLACED BY
15492589		03	-	101	202	1,2,3	-
15492573		02	AA	102	202	1,2,3	-
15492510		02	AA	102	201	1,2,3	-
15492508		03	-	101	201	1,2,3	-
12092218	OBSOLETE	04	AF	101	202	2,3,4	15492589
12066325	OBSOLETE	08	AF	102	202	2,3,4	15492573
12004188	OBSOLETE	07	AF	102	201	2,3,4	15492510
08917513	OBSOLETE	E	-	101	201	-	-
08917444	OBSOLETE	09	AF	101	201	2,3,4	15492508
08917443	OBSOLETE	F2	-	101	201	-	-

UNLESS OTHERWISE SPECIFIED DIMENSIONS ENCLOSED IN ( ) INDICATE REFERENCE DIMENSIONS AND NO TOLERANCE UNITS ARE ESTABLISHED

THIS DOCUMENT IS IN ACCORDANCE WITH ASME Y14.5M-1994 AS AMENDED BY THE 2003 ADDENDUM. DIMENSIONS AND TOLERANCING ADDENDUM-2003. SEPARATE PATTERNING OF FEATURES MAY BE OBTAINED SEPARATELY REGARDLESS OF DATUM REFERENCES.

ALL DIMENSIONS ARE IN INCHES

REFERENCE

(N/A) PROCESS SENSITIVE DIMENSION

DIMENSIONAL RANGE (IN) CHART

FROM	TO	TOLERANCE UNLESS OTHERWISE SPECIFIED
0	.500	±.005
.500	>.500	±.010

ANGULAR TOLERANCE 12°

THIRD ANGLE PROJECTION

DO NOT SCALE

USE MATH DATA

**DELPHI**

DELPHI PACKARD ELECTRIC SYSTEMS  
WARREN, OH

DR	DATE
APVD1 W. STEIN	03MY74
APVD2 D.E. THIRY	07MY74
APVD3 D.A. BURGNER	15MY74
APVD4 MATTHEW ROUSSEL	11JN04
APVD5	

SUBSTANCES OF CONCERN AND RECYCLED CONTENT PER DELPHI 10949001

MATERIAL: DX551263-P

DRAWING NAME: TAXI MOUN BOLT HEX HD

DRAWING NUMBER: 08917464

SIZE: A0  
SCALE: 2:1  
FRAME NO: 1 OF 1  
SHEET NO: 1 OF 1  
REV: R 09

## X-ON Electronics

Largest Supplier of Electrical and Electronic Components

*Click to view similar products for [Automotive Connectors](#) category:*

*Click to view products by [APTIV](#) manufacturer:*

Other Similar products are found below :

[003-018-000](#) [60403001](#) [60993906-B](#) [629515004020001](#) [M902-2131](#) [M902-2161](#) [72.330.1035.1](#) [73.353.4028.0](#) [F119300-B](#) [F166900](#)  
[F258300-B](#) [F358300-B](#) [F407400](#) [F444110](#) [F487000](#) [F509500B-B](#) [827153-1](#) [8N1515-32-24P](#) [9-1326729-8](#) [925474-1](#) [928905-1](#) [964562-4](#)  
[968782-1](#) [GT17SA-8DS-HU](#) [98891-1012](#) [98947-1016](#) [12004475-L](#) [12010290](#) [12010309-B](#) [12015454](#) [12020219-B](#) [12020308](#) [12041318-B](#)  
[12052225-L](#) [12052466](#) [12059125](#) [12064869](#) [12004327-B](#) [12010503-B](#) [12015308](#) [12015384](#) [12015909](#) [1-21030-1](#) [12041254](#) [12041318](#)  
[12047946-B](#) [12047957](#) [12047957-L](#) [12059473](#) [12066261](#)