

NOTA	SPECIFICATIONS
1	CONNECTEUR DOIT ETRE CONFORME AU CDC :96 238 404 99 FEMALE CONNECTOR ACCORDING TO SPECIFICATION PSA :96 238 404 99
2	CONNECTEUR SUIVANT: FEMALE CONNECTOR ACCORDING TO -CLASSE DE TEMPERATURE T3 SELON B217050 REV A TEMPERATURE CLASS T3 ACCORDING TO B217050 REV A -CLASSE DE VIBRATION MOTEUR SELON B217050 REV A ENGINE VIBRATOR CLASS ACCORDING TO B217050 REV A -CLASSE ETANCHEITE 2 SELON B217050 REV A SEALING CLASS 2 ACCORDING TO B217050 REV A
3	PRECONISATION D'UTILISATION / USER MANUAL REF FC1: PU 071/FC1'S REFERENCE: PU 071 REF PSA:96 556 834 99/PSA'S REFERENCE:96 556 834 99
4	ALVEOLE SUIVANT STE: 96 288 230 99 CAVITY ACCORDING TO: STE: 96 288 230 99
5	CONNECTEUR ET POSITION ALVEOLE CONFORMES AU PLAN D'INTERFACE 211FT0523 ET STE 96 339 622 99 FEMALE CONNECTOR AND CAVITY'S POSITION ACCORDING TO: DRAWING INTERFACE 211FT0523 ET STE 96 339 622 99
6	CONDUCTEUR SUIVANT STE :96 418 794 99 WIRE ACCORDING TO: STE :96 418 794 99
7	CONDITIONNEMENT SUIVANT NORME: E73 03 150G PACKAGING ACCORDING TO STANDARD: E73 03 150G
8	DIAMETRE DE L'ISOLANT DES FILS WIRE INSULATION DIAMETER :MINI=1.40 :MAXI=2.80
9	MASSE DU PRODUIT LIVRABLE :5g DELIVERY CONNECTOR WEIGHT : 5g
10	CHARNIERE DE PLAQUETTE ARRIERE ABSENTE OU CASSEE ADMISE NO WAFER HINGE OR WAFER HINGE BROKEN ALLOWED
11	DEFAUTS D'ASPECT SUR ZONES NON FONCTIONNELLES ADMIS VISUAL DEFECTS ON NO FUNCTIONAL AREAS ALLOWED

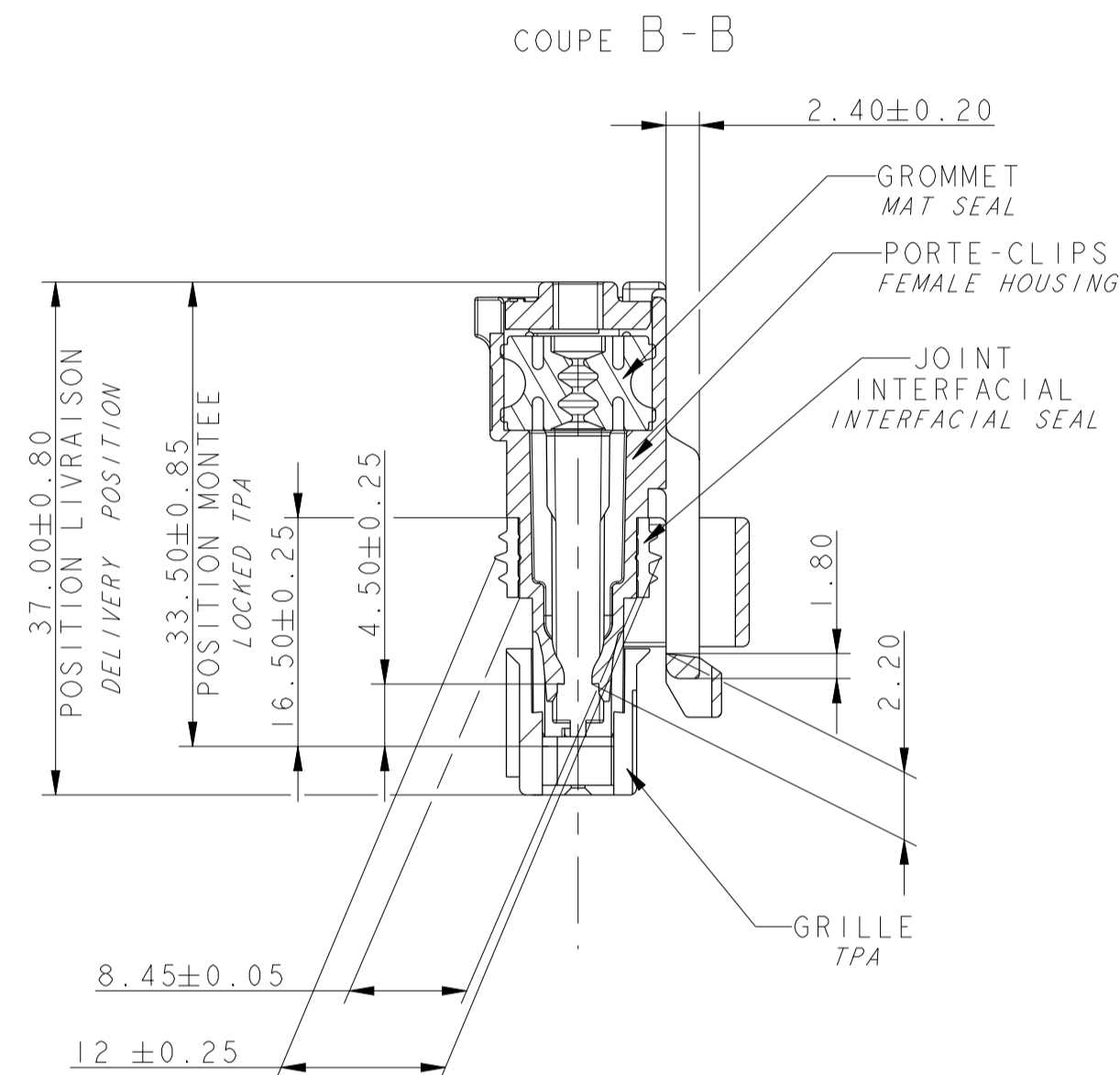

PORTE-CLIPS FEMALE HOUSING	211 1 0 073	PBT NON CHARGE PBT: 0% GF	NOIR BLACK
GRILLE TPA	211 M 0 100	PBT: 15% FV PBT: 15% GF	NOIR BLACK
	211 M 1 100		MARRON BROWN
	211 M 2 100		ROUGE RED
	211 M 3 100		ORANGE ORANGE
	211 M 4 100		JAUNE YELLOW
	211 M 5 100		VERT GREEN
	211 M 6 100		BLEU BLUE
	211 M 8 100		GRIS GREY
	211 M 9 100		BLANC WHITE
GROMMET MAT SEAL	211 M 108	SILICONE 30sh AUTOLUBRIFIE	VERT GREEN
JOINT INTERFACIAL INTERFACIAL SEAL	211 M 075	SILICONE 30sh 4% D'HUILE	BLEU BLUE
DESIGNATION DESCRIPTION	REF. MVL MVL'S REFERENCE	MATIERE MATERIAL	COULEUR COLOUR

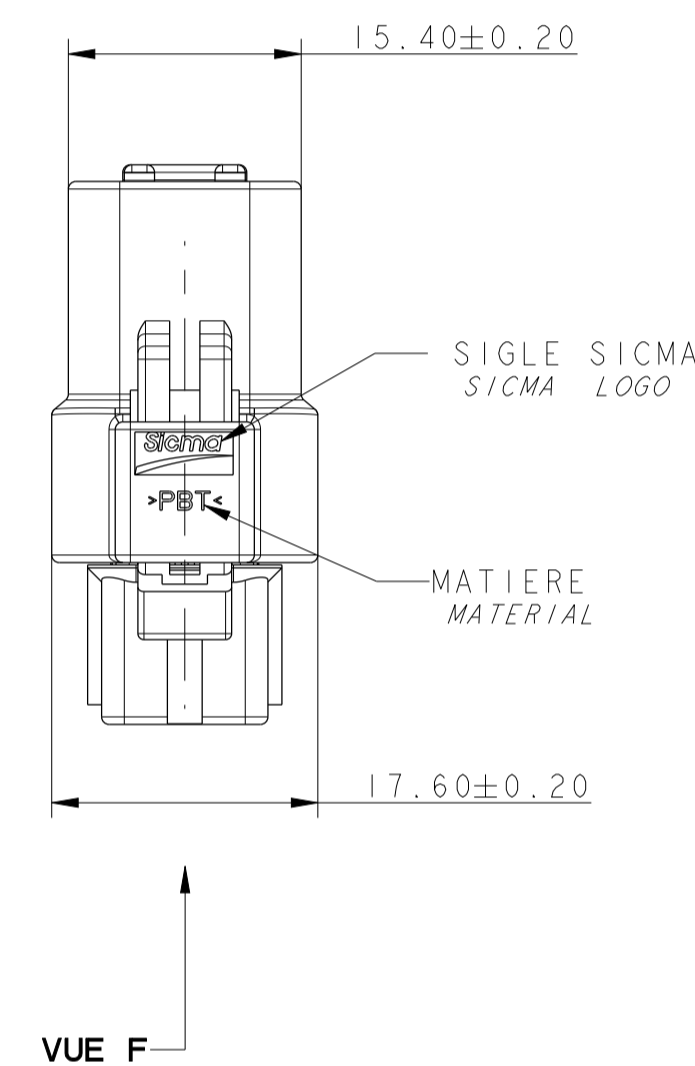
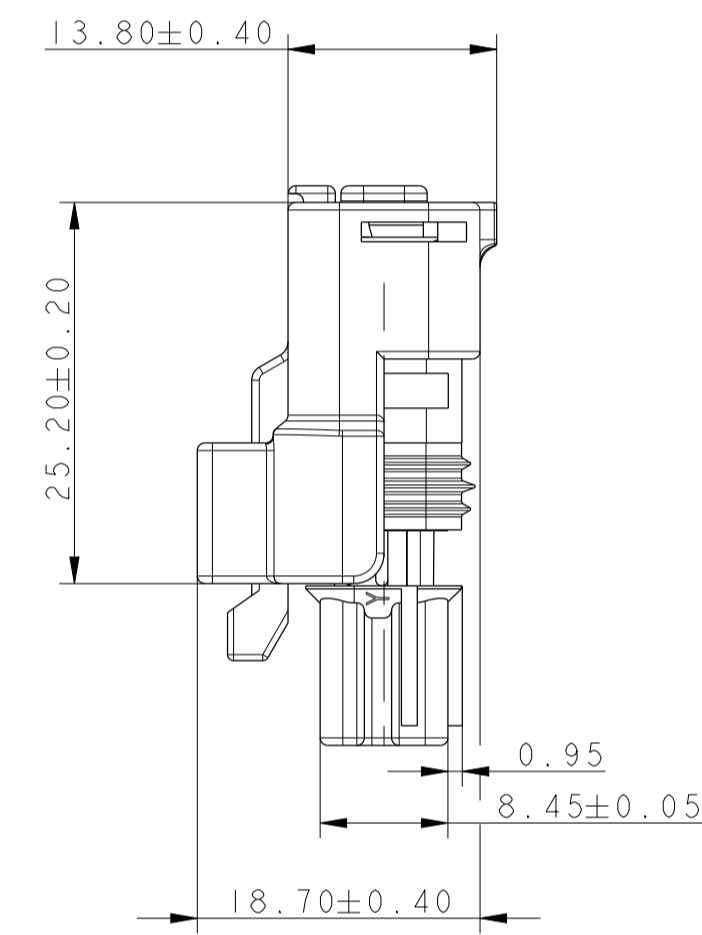
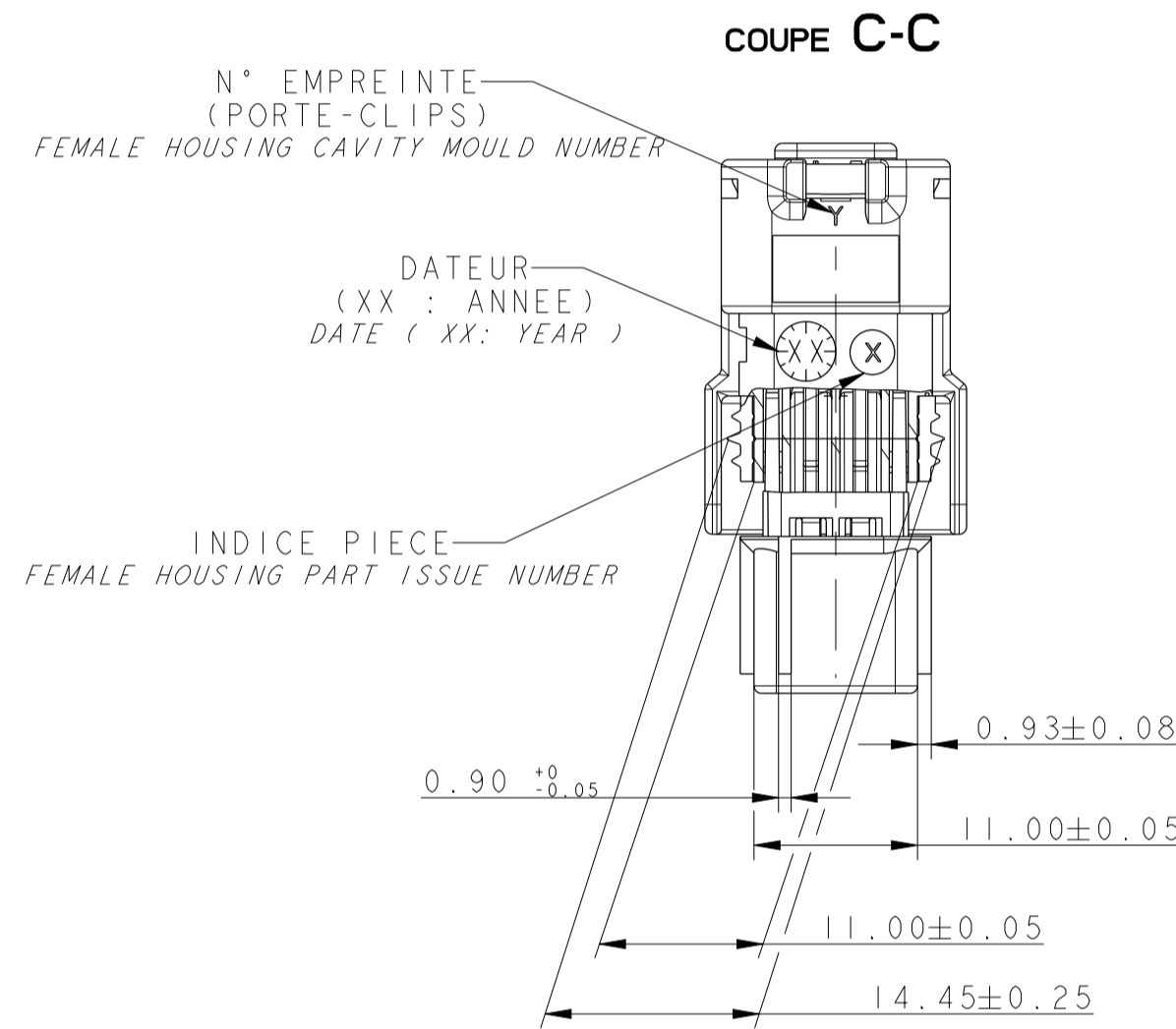
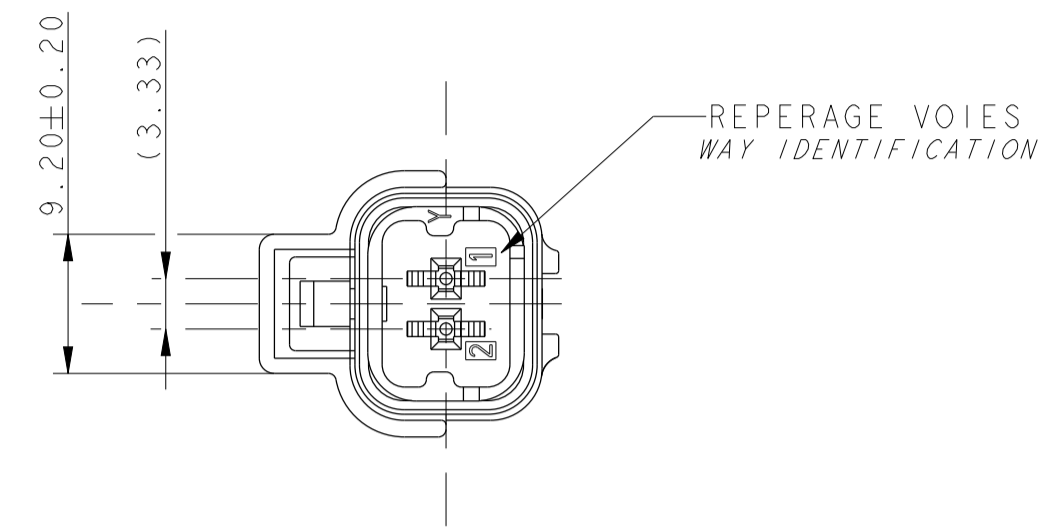
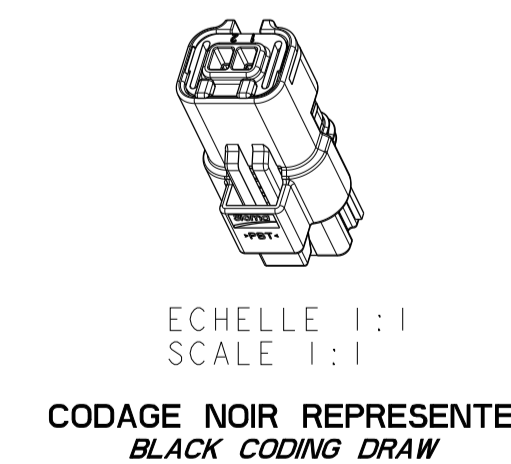
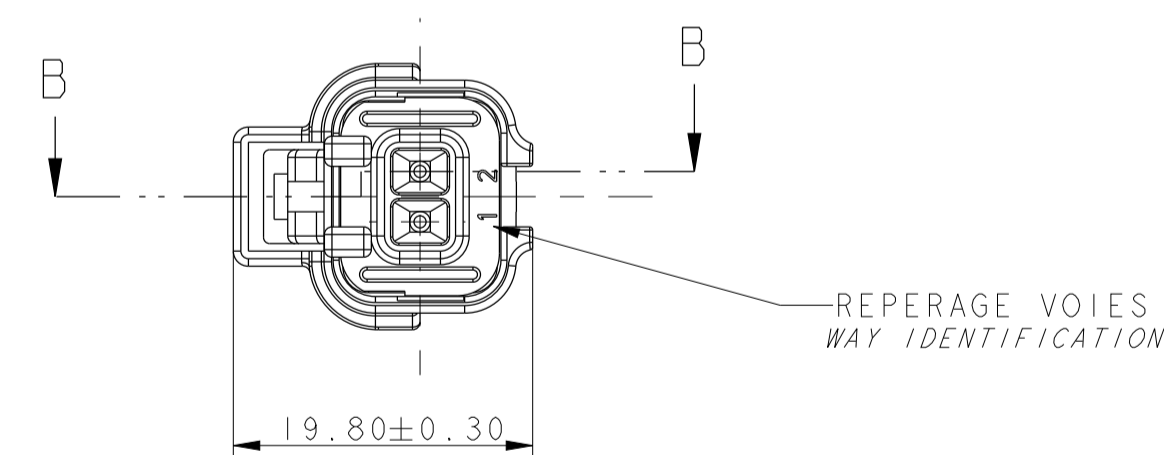

									VUE F VIEW F Tolérances : ±0.05	
3.85	2.95	11.00	0.25	1.55	2.50	1.15	11.00			
NOIR /BLACK	MARRON /BROWN	ROUGE /RED	ORANGE /ORANGE	JAUNE /YELLOW	VERT /GREEN	BLEU /BLUE	GRIS /GREY	BLANC /WHITE		COULEUR COLOUR
211 PC 02 25 0 149	211 PC 02 25 1 149	211 PC 02 25 2 149	211 PC 02 25 3 149	211 PC 02 25 4 149	211 PC 02 25 5 149	211 PC 02 25 6 149	211 PC 02 25 8 149	211 PC 02 25 9 149		PART NUMBER
A	A	A	A	A	A	A	A	A	PART REVISION	
10820158	10820159	10820160	10820161	10820162	10820163	10820164	10820165	10820166	PART NUMBER	
01	01	01	01	01	01	01	01	01	PART REVISION	
									DELPHI MVL	

DELPHI P/N ADDED

ECN-NO. POSITION CHANGE DESCRIPTION
NUMBER ECH POSITION MODIFICATION

PROJECT SPEC. SPECIFIC PRODUCT PACKAGING SPEC. SPECIFIC PACKAGING APPLICATION SPEC. SPECIFIC APPLICATION COPYRIGHT DELPHI CORPORATION AND/OR ITS AFFILIATES. ALL RIGHTS RESERVED. REVISED THIS DRAWING IS THE PROPERTY OF DELPHI CORPORATION AND CONTAINS DELPHI CONFIDENTIAL INFORMATION. THE REPRODUCTION, DISTRIBUTION AND SALE OF THIS DOCUMENT OR ITS CONTENTS OR ANY PART THEREOF WITHOUT EXPRESS AUTHORIZATION OF DELPHI CORPORATION IS PROHIBITED. LE PLAN EST LA PROPRIETE DE DELPHI CORPORATION ET CONTIEN DES INFORMATIONS CONFIDENTIELLES. LA REPRODUCTION, LA DISTRIBUTION ET LA VENTE DE CE DOCUMENT OU DE SES CONTENUX OU D'UNE PARTIE DE CE DOCUMENT SANS AUTORISATION ECRITEE, EST INTERDITE.

TOLERANCES ±0.1 ±0.2

CONTRIBUTOR: SEE TABLE

DATE: 2015/02/19

NAME: PASCAL MENARD

TITLE: 2WAY 15x08 FEMALE CONNECTOR

DESIGNATION: MINI SEALED 'NM' FAMILY

ECO EXP: 664 FE

CODE B.C.:

DRAWING NUMBER: 211FT0525

REF. PLAN:

STATE: A1

PART NUMBER: 211PC0225X149

REV.:

IND.:

SCALE: 1:1

See Table

X-ON Electronics

Largest Supplier of Electrical and Electronic Components

Click to view similar products for [Automotive Connectors](#) category:

Click to view products by [APTIV](#) manufacturer:

Other Similar products are found below :

[003-018-000](#) [60403001](#) [60993906-B](#) [629515004020001](#) [M902-2131](#) [M902-2161](#) [72.330.1035.1](#) [73.353.4028.0](#) [F119300-B](#) [F166900](#)
[F258300-B](#) [F358300-B](#) [F407400](#) [F444110](#) [F487000](#) [F509500B-B](#) [827153-1](#) [8N1515-32-24P](#) [9-1326729-8](#) [925474-1](#) [928905-1](#) [964562-4](#)
[968782-1](#) [GT17SA-8DS-HU](#) [98891-1012](#) [98947-1016](#) [12004475-L](#) [12010290](#) [12010309-B](#) [12015454](#) [12020219-B](#) [12020308](#) [12041318-B](#)
[12052225-L](#) [12052466](#) [12059125](#) [12064869](#) [12004327-B](#) [12010503-B](#) [12015308](#) [12015384](#) [12015909](#) [1-21030-1](#) [12041254](#) [12041318](#)
[12047946-B](#) [12047957](#) [12047957-L](#) [12059473](#) [12066261](#)