

SYMBOL DEFINITION		MISSING SYMBOLS	
A DIMENSION WITHOUT AN INSPECTION REPORT SYMBOL DOES NOT REQUIRE INSPECTION. IT MAY BE CONTROLLED ON THE INDIVIDUAL COMPONENT DRAWING.	TOTAL NO OF INSPECTIONS REQUIRED	15	17
	LAST NO. USED		18

DWG STATUS				ZONE	REVISION HISTORY				AUTH	DR	APVD 1	APVD 2	
DATE	STG	REV	N/P		CHG								
28JUN10	R	01	-	-		ALL PARTS - RELEASED				437646	JVM	JVM	RBS
11JA18	R	02	-	-		35088746 - UPDATED PART AVAILABILITY				438742	AGH	VMR	AGH
19JA18	R	03	-	-		35088745 - UPDATED PART AVAILABILITY				438799	AGH	VMR	AGH
01MR18	R	04	-	-		35088747 - UPDATED PART AVAILABILITY				439143	AGH	VMR	AGH
02MY18	R	05	-	-		35088745-46 - REMOVED INSULATOR HOLE FEATURE & ITS ASSOCIATED INFO; 35088747 - REVISED GRAPHICS				439662	LXA	JAA	AGH
05AP19	R	06	-	-		ALL PARTS - DIM #4 WAS 0 ± 2° AND ADDED GD&T PROFILE OF LINE CONTROL FRAME & DATUM A OVERALL INFO				441273	DAV	JAA	RBS

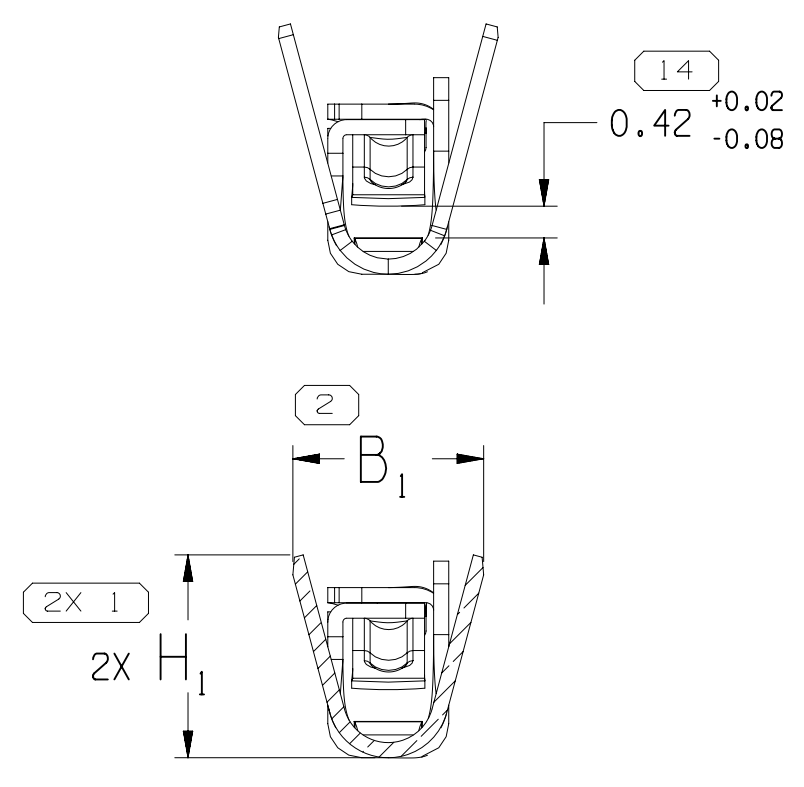
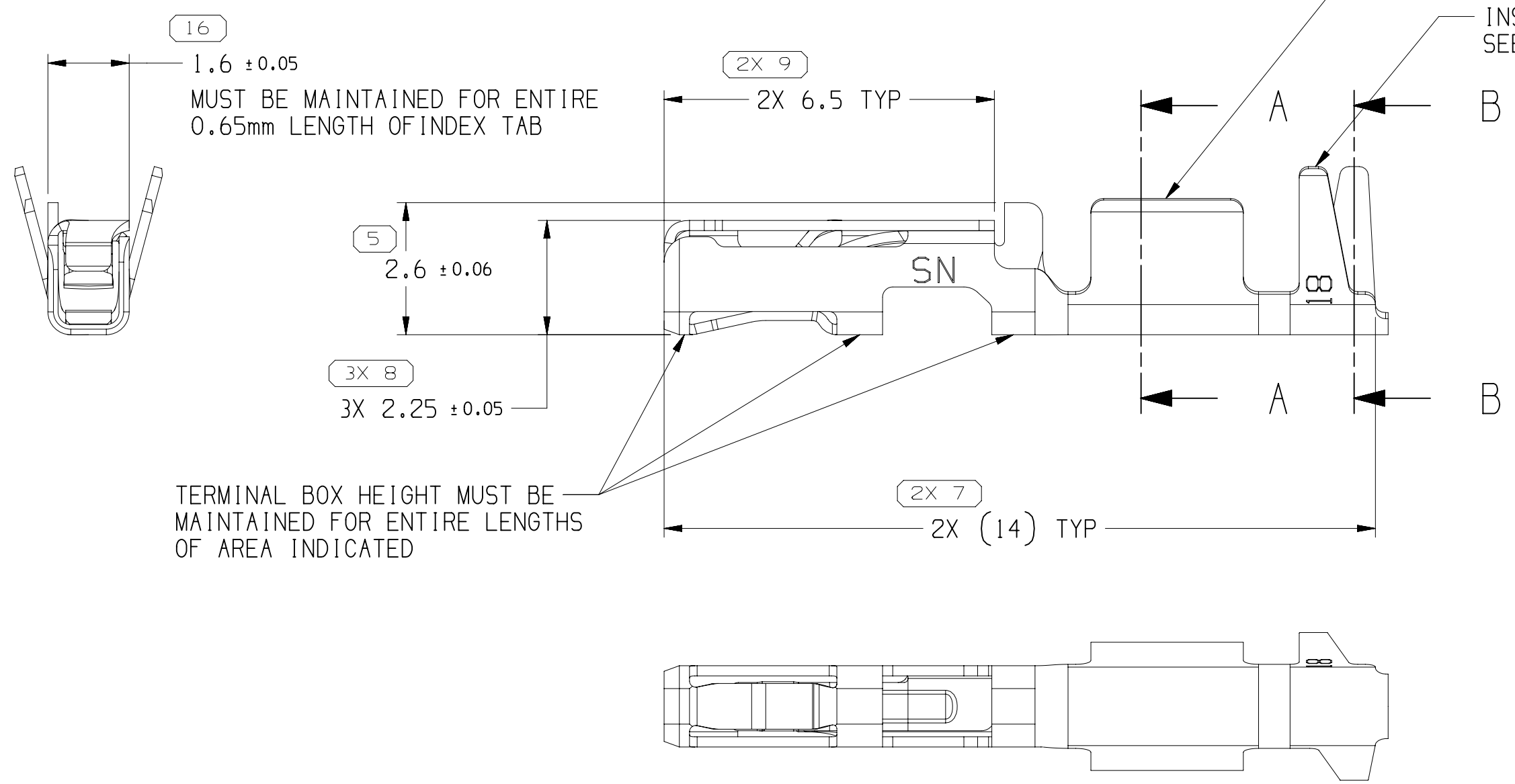
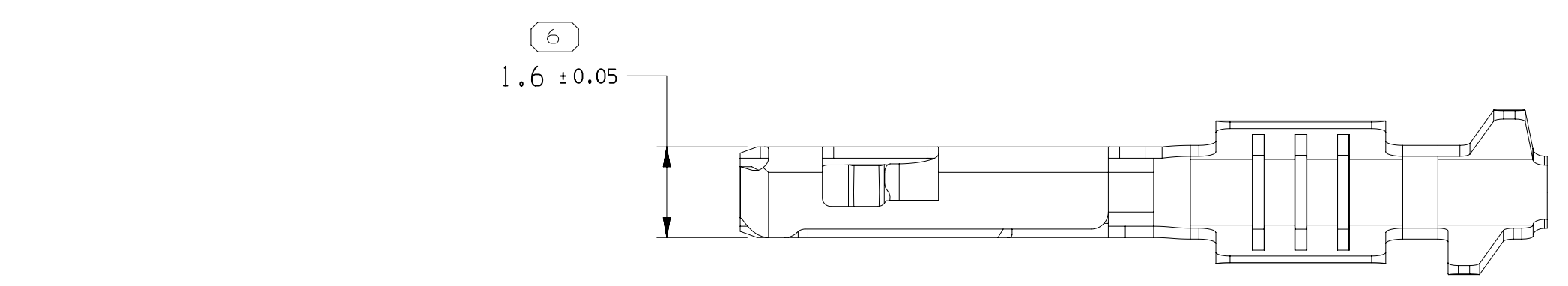

SECTION A-A SECTION B-B

NOTES

- UNLESS OTHERWISE SPECIFIED AND/OR INDICATED:
DIMENSIONS ARE TO FACE OF VIEW SHOWN AND AUTOMATICALLY ROUNDED BY COMPUTER FOR INSPECTION (SEE MATH MODEL FOR PRECISE DIMENSIONS). FOR ALL OTHER DIMENSIONS NOT SHOWN BUT REQUIRED FOR TOOL BUILD, SEE MATH MODEL FOR PRECISE TOOL PATH DATA.
- RECOMMENDED MATING BLADE THICKNESS 0.64±0.03mm
RECOMMENDED MATING BLADE WIDTH NOT TO EXCEED 1mm AND NO LESS THAN 0.6mm. SEE USCAR EWCAP-001 DRAWING (0.64 PIN) FOR OTHER MATING BLADE REQUIREMENTS.
- MAXIMUM CURRENT CAPACITY IS 7.5 AMPS WITH 0.8mm² COPPER CABLE.
- * DENOTES DIMENSIONS MADE AT CUT-OFF AND CRIMP DIE
- MAXIMUM INSULATION CRIMP WIDTH 1.77mm AND HEIGHT 2.3mm FOR CABLE SIZE UP TO 1.9mm O.D.
MAXIMUM CORE CRIMP WIDTH 1.67mm
- DO NOT PROBE, TEST OR OTHERWISE CONTACT THE INTERIOR REGION (THE SPRING OR ANY MOVING PART) OF THIS TERMINAL. SEVERE DAMAGE CAN OCCUR, COMPROMISING THE PERFORMANCE OF THE ELECTRICAL INTERFACE.
- PLATING TYPE:
1. REFLOW TIN 1.9-3.3 MICROMETERS THICK OVER NICKEL UNDERPLATE 0.13-0.5 MICROMETERS THICK

PLATING TYPE INFORMATION SHOWN ABOVE IS REFERENCE ONLY, PLATING REQUIREMENTS ARE CONTAINED IN APPLICABLE MATERIAL SPECIFICATION
- SEE TAXI P/N 13887649 FOR SIMILAR TERMINALS WITH DIFFERENT CONNECTOR CAVITY INDEX.
- PARTS MEET THE PERFORMANCE REQUIREMENTS OF GMW3191 DEC 2007 AND SAE/USCAR-2 R5 REVISIONS FOR THE FOLLOWING CLASSIFICATIONS:
TEMPERATURE CLASS 3(-40° C TO +125° C)
VIBRATION CLASS 1(ON BODY OR CHASSIS)
SEALING CLASS 1(UNSEALED)

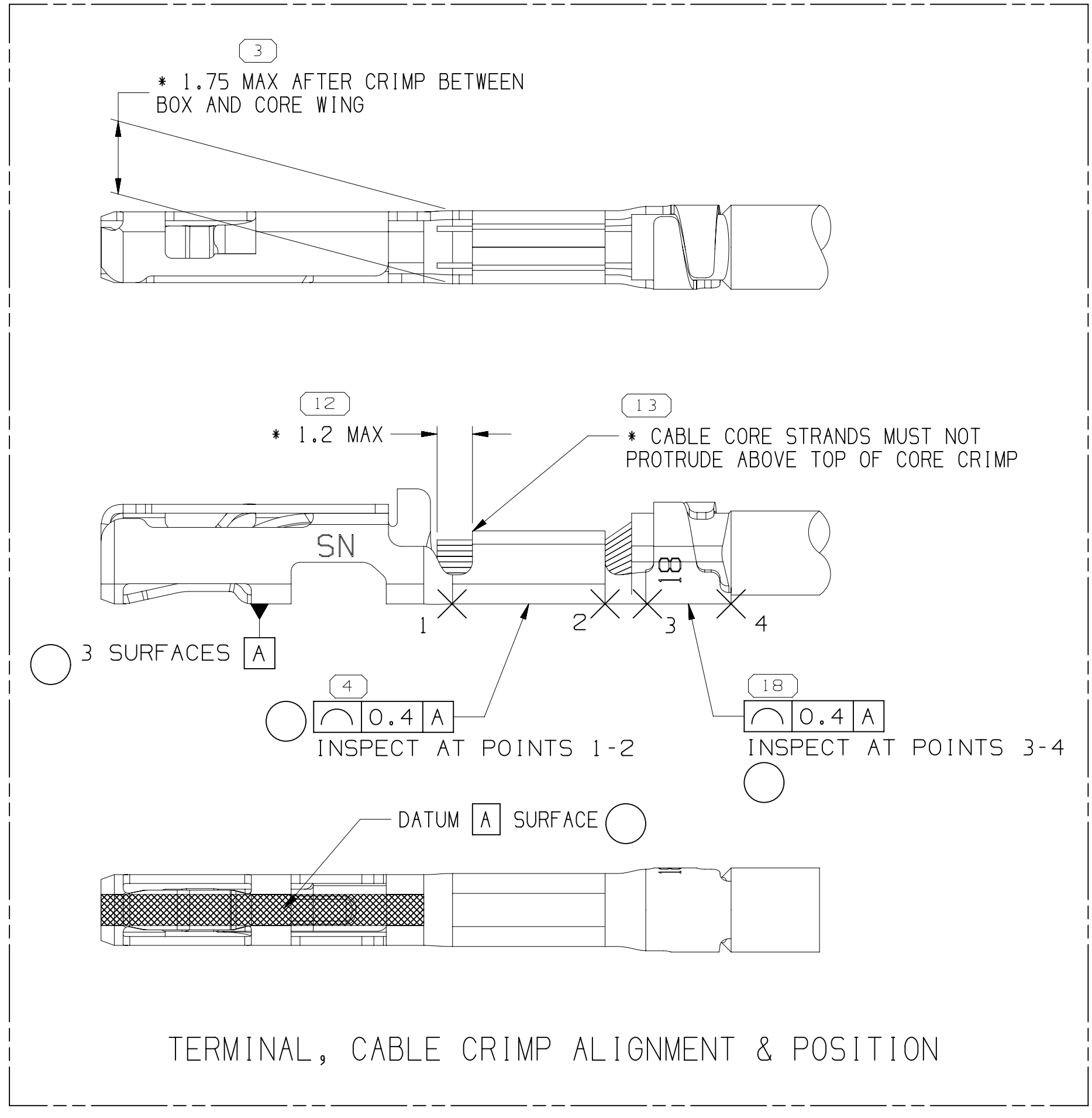

A LINE DRAWN THROUGH A PART NUMBER INDICATES THAT PHYSICAL PARTS ARE NOT AVAILABLE FOR ORDERING.	
PART NUMBERS THAT DO NOT HAVE A LINE PRESENT INDICATE THAT PHYSICAL PARTS ARE AVAILABLE FOR ORDERING.	
CONTACT APTIV SALES TO ASSURE AVAILABILITY OF PARTS.	
DWG TYPE	PART DRAWING
STYLE	
VOLUME (CM)	DISTR CODE
	D
UNLESS OTHERWISE SPECIFIED	
THIS DOCUMENT IS IN ACCORDANCE WITH ASME Y14.5M-1994 AS AMENDED BY THE GM GLOBAL DIMENSIONING AND TOLERANCING ADDENDUM-2001. SEPARATE PATTERNS OF FEATURES MAY BE GAGED SEPARATELY REGARDLESS OF DATUM REFERENCES.	
ALL DIMENSIONS ARE IN MILLIMETERS	
THIRD ANGLE PROJECTION	DO NOT SCALE
USE MATH DATA	NX
DIMENSIONAL RANGE (MM) CHART D	
FROM 0 TO 12	CHART D
TO >12	
TOLERANCE UNLESS OTHERWISE SPECIFIED	
+0.1	+0.2
ANGULAR TOLERANCE ±2°	

• APTIV •
CONNECTION SYSTEMS
WARREN, OH
COPYRIGHT 2017 APTIV. ALL RIGHTS RESERVED.

THIS DRAWING IS THE PROPERTY OF APTIV AND CONTAINS APTIV CONFIDENTIAL INFORMATION. THE REPRODUCTION, DISTRIBUTION AND UTILIZATION OF THIS DOCUMENT OR ITS RELATED CAD MATH DATA, AS WELL AS COMMUNICATION OF ANY CONTENT TO OTHERS, WITHOUT EXPRESS AUTHORIZATION, IS PROHIBITED.

DR	DATE
APVD1 J. VILLAMIL	03NO17
APVD2 J. VILLAMIL	03NO17
APVD3 ROBERT B SNADER	03NO17
APVD4	
APVD5	

SUBSTANCES OF CONCERN AND RECYCLED CONTENT PER APTIV 10949001

MATERIAL SEE CHART

DRAWING NAME
TAXI TERM F OCS 0.64 IUR SN

DRAWING NUMBER
13767042

SIZE	SCALE	FRAME NO	SHEET NO	STG	REV	N/P
A1	10:1	1 OF 1	3 OF 3	R	06	-

PART NO	REV	N/P	MATERIAL DESCRIPTION	CONTACT AREA PLATING TYPE (SEE NOTE 7)	CRIMP AREA PLATING TYPE (SEE NOTE 7)	I.D.	CABLE SIZE (mm ²)	CABLE DIA	B ₁ ±0.15	B ₂ ±0.25	(H ₁)	(H ₂)
35088745	02	AA	TIN PLATED COPPER ALLOY	1	1	18	0.75 - 0.8	1.7 - 1.9	2.52	2.88	2.68	3.31
35088746	02	AA	TIN PLATED COPPER ALLOY	1	1	21	0.35 - 0.5	1.2 - 1.83	2.04	2.8	2.06	3.17
35088747	02	AA	TIN PLATED COPPER ALLOY	1	1	25	0.13 - 0.22	0.81 - 1.2	1.54	1.74	1.56	1.77

X-ON Electronics

Largest Supplier of Electrical and Electronic Components

Click to view similar products for [Automotive Connectors](#) category:

Click to view products by [APTIV](#) manufacturer:

Other Similar products are found below :

[003-018-000](#) [60403001](#) [60993906-B](#) [629515004020001](#) [M902-2131](#) [M902-2161](#) [72.330.1035.1](#) [73.353.4028.0](#) [F119300-B](#) [F166900](#)
[F258300-B](#) [F358300-B](#) [F407400](#) [F444110](#) [F487000](#) [F509500B-B](#) [827153-1](#) [8N1515-32-24P](#) [9-1326729-8](#) [925474-1](#) [928905-1](#) [964562-4](#)
[968782-1](#) [GT17SA-8DS-HU](#) [98891-1012](#) [98947-1016](#) [12004475-L](#) [12010290](#) [12010309-B](#) [12015454](#) [12020219-B](#) [12020308](#) [12041318-B](#)
[12052225-L](#) [12052466](#) [12059125](#) [12064869](#) [12004327-B](#) [12010503-B](#) [12015308](#) [12015384](#) [12015909](#) [1-21030-1](#) [12041254](#) [12041318](#)
[12047946-B](#) [12047957](#) [12047957-L](#) [12059473](#) [12066261](#)