

# ATCA-7365-CE

## AdvancedTCA Processor Blade

■ Embedded Computing for  
Business-Critical Continuity™

**The ATCA-7365-CE processor blade is an ideal solution for data processing applications requiring powerful server class processing performance, flexible mass storage and network options**

- High performance Intel® Architecture processor blade
- Two 4- or 6-core Intel® Xeon® processors, E5620 or E5645 (2.4 GHz)
- Up to 96GB main memory
- Fully supported by the ATCA-736X RTM family
- Hot-swappable hard disk with flexible choice of storage options
- RAID 0/1 support
- Multiple network and storage I/O connectivity
- 10GbE ATCA fabric interface, PICMG 3.1 Option 1, 9
- Designed for Commercial ATCA in a temperature controlled environment
- Multiple software packages including operating systems

The Emerson Network Power ATCA-7365-CE is an Intel® Architecture server blade that offers scalable, high-performance computing power for tasks that store, process and forward large amounts of data for applications where reliability or bill-per-minute are critical. It is based on open-standards AdvancedTCA® (ATCA®) technology to provide commercial IT applications with improved serviceability, power and space efficiency over typical rack mount server-based solutions.

With two 4- or 6-core Intel® Xeon® processors from the E5600 series, the ATCA-7365-CE processor blade enables best-in-class compute performance in an ATCA form factor. The PICMG® 3.1 compliant fabric interface provides 10 Gigabit Ethernet (10Gbps) capability for applications requiring higher network throughput in the backplane.

Multiple network and storage I/O interfaces allow the integration into different network infrastructures such as data processing applications and the carrier enterprise environment. Main memory configuration and mass storage options can be flexibly configured providing a perfect fit to the applications needs. Hardware RAID 0 and 1 is supported for locally and external connected disk drives.

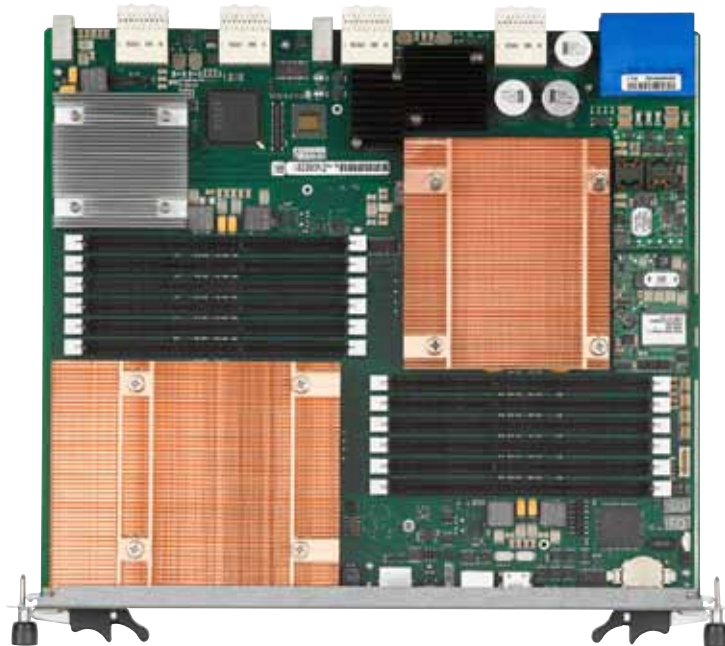

**AdvancedTCA®**

  
**EMERSON™**  
Network Power

## ATCA-7365-CE Block Diagram

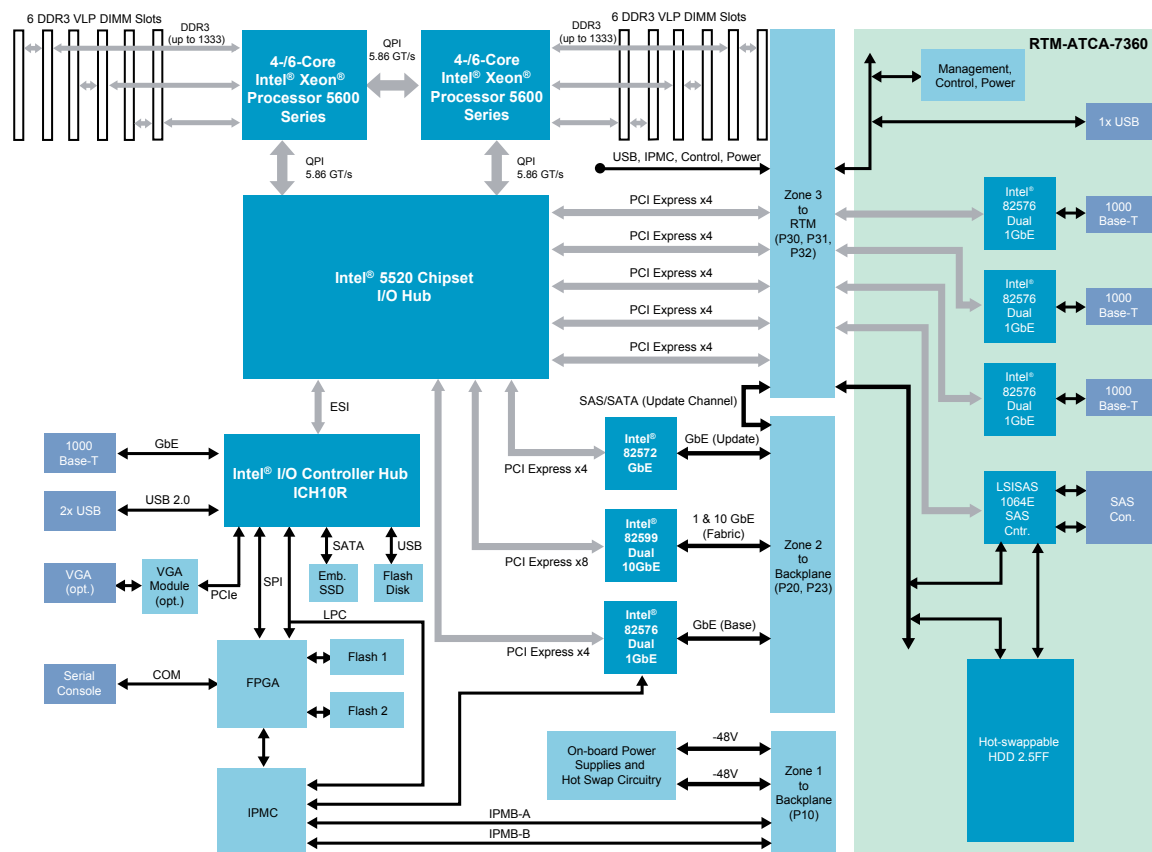

### Standard Networking Support

The ATCA-7365-CE processor blade provides PICMG 3.0 base interface connectivity in a dual star configuration using standard Gigabit Ethernet (GbE) technology.

The PICMG 3.1 fabric interface features both dual 10Gbps (Option 9) and dual 1Gbps (Option 1) Ethernet capability. A further 1Gbps Ethernet backplane connection is available on the ATCA update channel. External network connectivity includes 10/100/1000Base-T Ethernet via RJ-45 connector on the blade faceplate. Several rear transition module (RTM) configurations support up to six additional 10/100/1000Base-T connections.

### Processor Complex

Both Intel® Xeon® processors are connected together via QPI interconnect to share memory resources. The processors can access the entire I/O subsystem via the Intel® 5520 chipset I/O hub. The I/O subsystem consists of:

- Intel® I/O Controller Hub ICH10R
- Intel® 82572 Gigabit Ethernet controller
- Intel® 82576 dual Gigabit Ethernet controllers
- Intel® 82599 dual 10 Gigabit Ethernet controller
- Intel® 82580 dual 10 Gigabit Ethernet controller (on optional RTM)
- Intel® i350 quad Gigabit Ethernet controller (on optional RTM)
- LSI Logic LSISAS1064E SAS controller (on optional RTM)

## Software Support

The ATCA-7365-CE blade can be configured with a variety of software offerings, from firmware-only to fully integrated and verified software operating environments.

### FIRMWARE

Firmware-only blade-level support is offered for customers taking on the integration and verification responsibilities. It provides all the boot and IPMC firmware required for an ATCA blade.

The BIOS firmware includes support for:

- Unified Extensible Firmware Interface (UEFI)
- Power management support, ACPI 3.0b
- Multiple boot options including:
  - ▲ Local and external hard disks
  - ▲ On-board flash disk
  - ▲ External USB boot media
  - ▲ PXE boot via ATCA base interface
  - ▲ iSCSI boot via ATCA base interface with operating systems supporting UEFI
- RAID 0/1 support via LSI SAS BIOS extension
- Serial redirection of the BIOS console
- Serial over LAN of the BIOS console via ATCA base interface
- BIOS upgrade via local host

### INTELLIGENT PLATFORM MANAGEMENT CONTROL

The ATCA-7365-CE features an intelligent platform management controller (IPMC). The IPMC is a management subsystem providing monitoring, event logging, and recovery control. The IPMC serves as the gateway for management applications to access the platform hardware. Features include:

- Compliance with PICMG 3.0 and IPMI 1.5
- Rollback capability if IPMC image upgrade failed
- Firmware (BIOS, IPMC, FPGA) upgradable from IPMI interface (IPMB) and/or locally, PICMG HPM.1 support or via Basic Blade Services (BBS) firmware upgrade utility
- Support for serial port redirection over LAN interface (IPMI 2.0 compliant)

### SUPPORTED OPERATING SYSTEMS

- Red Hat RHEL 5.5 certified
- Wind River PNE LE 3.0
- Prepared for Microsoft® Windows® Server 2008
- VMware ESX/ESXi 4.1 certified (requires VGA module)

To better exploit the CPU and I/O resources of the blade, RHEL 5.5 supports CPU and I/O virtualization using XEN/KVM. In addition RHEL 5.5 provides code for enabling the processor power management to help enhancing energy efficiency of the blade.

Emerson ATCA blades can be configured with optional software that includes Basic Blade Services. The ATCA-7365-CE is verified with Wind River PNE 3.0. This distribution comes with all Linux Support Packages (LSPs) to support Emerson ATCA blades as well as user applications. Basic Blades Services (BBS) software is provided to enable a set of ATCA hardware and software components into a fully integrated platform.

Basic Blade Services include:

- Hardware Platform Management including local IPMC, LED, E-Keying and blade extraction software
- Firmware upgrade utility
- Local management access (CLI)

### RELEVANT STANDARDS

- Linux Foundation
- Service Availability Forum™ (SA Forum)
  - ▲ Hardware Platform Interface (HPI) – HPI-B.02

## Rear Transition Modules

Several RTM variants are available to support different I/O configurations at the RTM faceplate.

RTM-ATCA-7360 includes:

- One (1) USB 2.0 interface
- Six (6) Gigabit Ethernet interfaces, 10/100/1000Base-T, RJ-45 connector
- Two (2) SAS interfaces, SFF-8470 connector
- Disk bay for one (1) hot-swappable hard disk, 2.5"

RTM-ATCA-7360-L includes:

- One (1) USB 2.0 interface
- Two (2) Gigabit Ethernet interfaces, 10/100/1000Base-T, RJ-45 connector
- Two (2) SAS interfaces, SFF-8470 connector
- Disk bay for one (1) hot-swappable hard disk, 2.5"

RTM-ATCA-736X-DD supports:

- Two (2) Gigabit Ethernet interfaces, 10/100/1000Base-T, RJ-45 connectors
- Two (2) disk bays for hot-swappable hard disks, 2.5"

RTM-ATCA-736X-10G supports:

- Four (4) 10 Gigabit Ethernet interfaces, SFP+/SFP
- Four (4) Gigabit Ethernet interfaces 10/100/1000Base-T, RJ-45 connectors
- Two (2) SAS interfaces, SFF-8470 connector
- Disk bay for one (1) optional hot-swappable hard disk, 2.5"

RTM-ATCA-736X-10G-SP supports:

- Six (6) 10 Gigabit Ethernet interfaces, SFP+/SFP
- Four (4) Gigabit Ethernet interfaces, 10/100/1000Base-T, RJ-45 connectors

## Hardware

### PROCESSOR

- Two 4- or 6-core Intel® Xeon®, E5620 or E5645 (2.4 GHz) processors. Note 1
- QuickPath Interface (QPI) – 5.86 GT/s
- 12MB L3 cache (per processor)
- 64-bit mode extension (EM64T)
- SMP support

### MEMORY

- DDR3-800/1066/1333 memory controllers integrated into processors. Note 2
- Total of six independent memory channels
- From 2 to 96GB memory configurations supported
- 4MB primary firmware flash, 4MB redundant flash for failsafe operation
- Reset persistent memory, 16MB SRAM, 64MB flash (optional). Note 3

### MASS STORAGE

- Embedded USB flash disk, 4GB (higher capacity upon request)
- On-board solid state disk at SATA, up to 120GB (optional). Note 3
- Hot-swappable hard disk on RTM
- Hard disk drive options including
  - ▲ Enterprise class disks (various capacity options)
  - ▲ 80GB SATA disk with extended temperature range

Note 1: Other processor variants on request

Note 2: 1333 E5645 only

Note 3: Persistent memory and solid state disk mutually exclusive

Note 4: The number of interfaces depends from the RTM variant

Note 5: Do not install in a shelf powered from -60 VDC (TNV-2)

### COUNTERS /TIMERS

- Real-time clock
- Programmable watchdog timer

### BASE AND FABRIC INTERFACES

- Dual star configuration
- PICMG 3.0 base interface compliant, Gigabit Ethernet (1.0Gbps)
- PICMG 3.1 fabric interface compliant
  - ▲ PICMG 3.1, Option 1 – Single, redundant Gigabit Ethernet pair (1.0Gbps)
  - ▲ PICMG 3.1, Option 9 – Single, redundant 10 Gigabit Ethernet pair (10Gbps)
- PICMG 3.0 Update Channel Gigabit Ethernet (1.0Gbps)

### EXTERNAL INTERFACES

- Front panel
  - ▲ 10/100/1000Base-T Ethernet (1), RJ-45
  - ▲ Serial console (1), RJ-45
  - ▲ USB 2.0 (2)
  - ▲ Optional VGA interface
- Rear transition module
  - ▲ USB 2.0 (1)
  - ▲ Gigabit Ethernet interfaces (up to 6), optional, RJ-45, Note 4
  - ▲ SAS interfaces (2), SFF-8470

### POWER REQUIREMENTS

- Dual-redundant –48 VDC (SELV) rail. Note 5
- Input range: –39 to –57 VDC
- Power consumption including RTM
  - ▲ Typical: 230 W - 270 W
  - ▲ Maximum: 330 W

### THERMAL CHARACTERISTICS

- Operating range: +5 °C to 35 °C
- Airflow requirements: 40 CFM

### RELEVANT BLADE SIZE

- 8U form factor, 280 mm X 322.5 mm, single slot

### RELEVANT STANDARDS

- PICMG 3.0 (form factor, IPMI, base interface, hot swap, RTM)
- PICMG 3.1, Option 1, 9

Ordering Information	
Part Number	Description
ATCA-7365-24GB-CE	Commercial ATCA processor blade, dual E5645 6-core (2.4 GHz), 12X DIMM sockets, 6X 4GB, 10G support
ATCA-7365-24GB-V-CE	Commercial ATCA processor blade, dual E5645 6-core (2.4 GHz), 12X DIMM sockets, 6X 4GB, 10G support, on-board VGA module
ATCA-7365-24GB-L-CE	Commercial ATCA processor blade, dual E5620 4-core (2.4 GHz), 12X DIMM sockets, 6X 4GB, 10G support
ATCA-7360-MEM-2G	2GB DDR3 VLP memory module for ATCA-736X product series
ATCA-7360-MEM-4G	4GB DDR3 VLP memory module for ATCA-736X product series
ATCA-7360-MEM-8G	8GB DDR3 VLP memory module for ATCA-736X product series
RTM-ATCA-7360	RTM for the ATCA-736X product series, 6X GbE, 2X SAS, 1X slot for optional HDD
RTM-ATCA-7360-L	RTM for the ATCA-736X product series, 2X GbE, 2X SAS, 1X slot for optional HDD
ATCA7360-HDD1-SAS	147GB SAS HDD kit for the RTM-ATCA-7360. See Note 1
ATCA7360-HDD2-SAS	300GB SAS HDD kit for the RTM-ATCA-7360. See Note 1
ATCA7360-HDD4-SAS	600GB SAS HDD kit for the RTM-ATCA-7360. See Note 1
ATCA7360-HDD3-SATA	80GB SATA HDD (ext. temp.) kit for the RTM-ATCA-7360. See Note 1
RTM-ATCA-7360-HDDKIT	Carrier and mounting kit for HDD or SSD devices used with RTM-ATCA-7360 or RTM-ATCA-7360-L (no disk included)
RTM-ATCA-736X-DD	RTM for the ATCA-736X product series, 2X GbE, 2X slot for optional HDD
RTM-ATCA-736X-DD-300	RTM for the ATCA-736X product series, 2X GbE, 2X 147GB SAS HDD included
RTM-ATCA-736X-DD-600	RTM for the ATCA-736X product series, 2X GbE, 2X 300GB SAS HDD included
RTM-ATCA-736X-DD-1K2	RTM for the ATCA-736X product series, 2X GbE, 2X 600GB SAS HDD included
RTM-ATCA-736X-10G	RTM for the ATCA-7365, ATCA-737X and ATCA-747X product series, 4x 10GbE (SFP+), 4x GbE, 1x slot for optional HDD
ATCA736X-HDD1-SAS	300GB SAS HDD for the RTM-ATCA-736X-10G
ATCA736X-HDD2-SAS	600GB SAS HDD for the RTM-ATCA-736X-10G
RTM-ATCA-736X-10G-SP	RTM for the ATCA-7365, ATCA-737X and ATCA-747X product series, 6x 10GbE (SFP+), 4x GbE
ATCA7360-MMOD-SATA3	120GB on-board solid state disk at SATA for ATCA-736X product series. See Note 2
ATCA7360-MMOD-SATA4	50GB on-board solid state disk at SATA for ATCA-736X product series. See Note 2
ATCA7360-SFMMOD	Reset persistent memory, 16MB SRAM, 64MB flash for the ATCA-736X product series. See Note 2
RJ45-DSUB-ATCA	RJ-45 DSUB cable for the ATCA-7140, 7X50, 736X, 737X, 747X blades
SA-BBS-WR30-7360	DVD - BBS SW and WR PNE 3.0 for ATCA-7360 and ATCA-7365. See Note 3
SA-BBS-WR42-7360	DVD - BBS SW and WR Linux 4.2 for ATCA-7360 and ATCA-7365. See Note 3

Note 1: Optional carrier kit for RTM-ATCA-7360 and RTM-ATCA-7360-L

Note 2: Persistent memory and solid state disk mutually exclusive

Note 3: License for a single blade

Regulatory Compliance	
Item	Description
CE Conformity	Directive 2004/108/EC, Directive 2006/95/EC
EMC	EN 55022 Information technology equipment - Radio disturbance characteristics - Limits and methods of measurement
	EN 55024 Information technology equipment - Immunity characteristics - Limits and methods of measurement
	CFR 47 FCC Part 15 Subpart B, Class A (US); FCC Part 15 - Radio Frequency Devices; Subpart B: Unintentional Radiators
	AS/NZS CISPR 22 (Australia/New Zealand), Limits and Methods of Measurement of Radio Disturbance Characteristics of Information Technology Equipment
	VCCI Class A (Japan), Voluntary Control Council for Interference by Information Technology Equipment
	CISPR 22 Information technology equipment – Radio disturbance characteristics – Limits and methods of measurement
	CISPR 24 Information technology equipment – Immunity characteristics – Limits and methods of measurement
Safety	Certified to UL/CSA 60950-1, EN 60950-1 and IEC 60950-1 CB Scheme
	Safety of information technology equipment, including electrical business equipment
RoHS/WEEE compliance	DIRECTIVE 2002/95/EC OF THE EUROPEAN PARLIAMENT AND OF THE COUNCIL on the restriction of the use of certain hazardous substances in electrical and electronic equipment (RoHS)
	DIRECTIVE 2002/96/EC OF THE EUROPEAN PARLIAMENT AND OF THE COUNCIL on waste electrical and electronic equipment (WEEE)
Interoperability	Designed to operate within a system environment providing a minimum of 40CFM air flow

**SOLUTION SERVICES**

Emerson Network Power provides a portfolio of solution services optimized to meet your needs throughout the product lifecycle. Design services help speed time-to-market. Deployment services include global 24x7 technical support. Renewal services enable product longevity and technology refresh.

PICMG, AdvancedTCA, ATCA, AdvancedMC and the AdvancedTCA logo are trademarks of PICMG. Service Availability is a proprietary trademark used under license. Intel and Xeon are trademarks of Intel Corporation or its subsidiaries in the United States and other countries. Microsoft and Windows are registered trademarks of Microsoft Corporation. All other product or service names are the property of their respective owners.

This document identifies products, their specifications, and their characteristics, which may be suitable for certain applications. It does not constitute an offer to sell or a commitment of present or future availability, and should not be relied upon to state the terms and conditions, including warranties and disclaimers thereof, on which Emerson Network Power may sell products. A prospective buyer should exercise its own independent judgment to confirm the suitability of the products for particular applications. Emerson Network Power reserves the right to make changes, without notice, to any products or information herein which will, in its sole discretion, improve reliability, function, or design. Emerson Network Power does not assume any liability arising out of the application or use of any product or circuit described herein; neither does it convey any license under its patent or other intellectual property rights or under others. This disclaimer extends to any prospective buyer, and it includes Emerson Network Power's licensee, licensee's transferees, and licensee's customers and users. Availability of some of the products and services described herein may be restricted in some locations.

**Emerson Network Power.**  
The global leader in enabling  
*Business-Critical Continuity™*.

- AC Power
- Embedded Power
- Precision Cooling
- Connectivity
- Infrastructure Management & Monitoring
- Racks & Integrated Cabinets
- DC Power
- Outside Plant
- Services
- Embedded Computing
- Power Switching & Controls
- Surge Protection

**Emerson Network Power**

**Offices:** Tempe, AZ U.S.A. 1 800 759 1107 or +1 602 438 5720  
 Paris, France +33 1 60 92 31 20 • Munich, Germany +44 1509 236490 • Tel Aviv, Israel +972 99560361  
 Hong Kong +852 2176 3540 • Shanghai, China +86 21 3395 0289 • Tokyo, Japan +81 3 5403 2730 • Seoul, Korea +82 2 3483 1500

**EmersonNetworkPower.com/EmbeddedComputing**

Emerson, Business-Critical Continuity and Emerson Network Power are trademarks of Emerson Electric Co. or one of its affiliated companies. ©2011 Emerson Electric Co.

ATCA7365CE-D4 03/21/12

## X-ON Electronics

Largest Supplier of Electrical and Electronic Components

*Click to view similar products for [artesyn embedded technologies](#) manufacturer:*

Other Similar products are found below :

[MP4-2P-00](#) [AP6C69RAL](#) [73-550-0333I](#) [73-951-0001C](#) [73-951-0046](#) [MCASE-820](#) [AXP1410](#) [NPS43-M](#) [IVS1-5J1-1W0-5P1-05-B-580](#)  
[HPR12K-00](#) [LCM1500U-T-4](#) [LCM300N-T-4](#) [LES20A24-3V3EJ](#) [LPT53](#) [074623B](#) [UMP1T-S2Y-S2Y-S2Y-S2Y-S2L03413](#) [VPX3000-CBL-](#)  
[DC](#) [LPT23](#) [LPT46](#) [LPQ202-M](#) [AXA01B36-L](#) [AXP640-DC2](#) [AEO30F48N-L](#) [MVME8100-202200401S](#) [NFS110-7624J](#) [NPT42-M](#) [LCC600-](#)  
[28U-9P](#) [73-769-003](#) [LPS254-CEF REV AB+](#) [RTM-ATCA-7360](#) [CENT-2000-ACB-R30](#) [ATA01C18-L](#) [LCM600L-A](#) [IVS1-5R0-00-A](#) [iMP8-](#)  
[3E0-1E0-4LL0-30-A](#) [LPS55-M](#) [VS1-L4-00-CE](#) [IMP8-2E-1D-1L-1Q-4LE-00](#) [IMP8-2E-1Q-4LL-4LL-00](#) [73-950-003T](#) [73-699-000](#)  
[LCM3000W-T](#) [DS1600SPE-3](#) [MP1-1W-03](#) [MVME2502-HDMNTKIT1](#) [IMP1-5N0-1E0-4LE0-03-A](#) [73-690-0001M](#) [700-014447-0000](#) [73-](#)  
[772-002](#) [73-551-0012I](#)