

ATCA-7365

AdvancedTCA Processor Blade

Data Sheet

The ATCA-7365 processor blade is an ideal solution for communications equipment requiring powerful server class processing performance, flexible mass storage and network options

- High performance Intel® Architecture processor blade
- Two 6-core Intel® Xeon® processors L5638 (2.0 GHz)
- Up to 192GB main memory
- Hot-swappable hard disk with flexible choice of storage options
- RAID 0/1 support
- Fully supported by the ATCA-736X RTM family
- Multiple network and storage I/O connectivity
- Optional on-board solid state disk with large capacity
- Option 9 (1/10GbE) ATCA fabric interface
- Designed for NEBS and ETSI compliance
- Multiple software packages including operating systems

The Artesyn Embedded Technologies ATCA-7365 is an Intel® Architecture server blade that delivers a combination of performance and flexibility to help drive the successful implementation of next-generation telecom networks and communication infrastructures. It builds on the AdvancedTCA® (ATCA®) standard to provide the right product at the right time to meet the needs of communication industries.

With two 6-core Intel® Xeon® processors L5638, the ATCA-7365 processor blade enables best-in-class compute performance in an ATCA form factor. The PICMG® 3.1 compliant fabric interface provides 10 Gigabit Ethernet (10Gbps) capability for applications requiring higher network throughput in the backplane.

Multiple network and storage I/O interfaces allow the integration into different network infrastructures such as telecommunication central offices and network data centers. Main memory configuration and mass storage options can be flexibly configured providing a perfect fit to the applications needs. Hardware RAID 0 and 1 is supported for locally and externally connected disk drives.

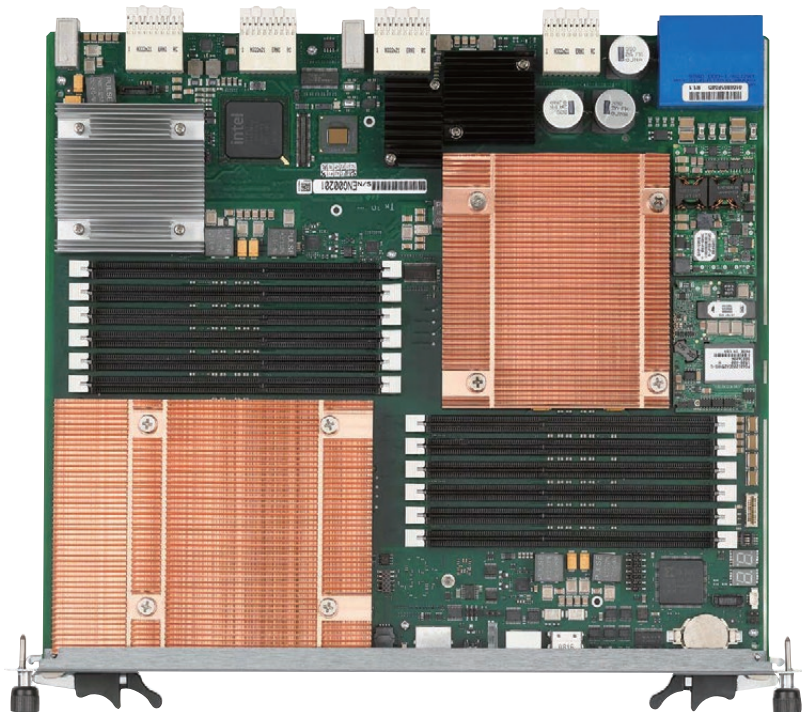

AdvancedTCA®

ATCA-7365 Block Diagram

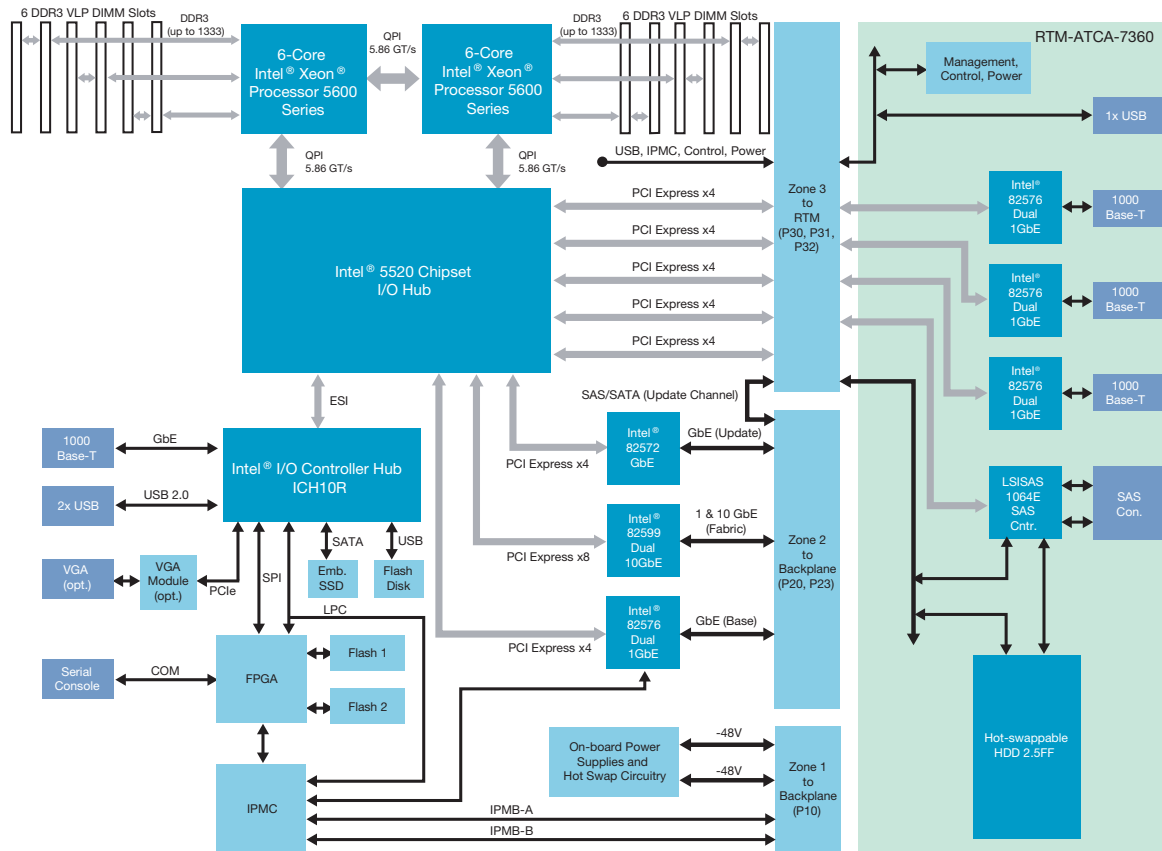

Standard Networking Support

The ATCA-7365 processor blade provides PICMG 3.0 base interface connectivity in a dual star configuration using standard Gigabit Ethernet (GbE) technology.

The PICMG 3.1 fabric interface features both dual 10Gbps (Option 9) and dual 1Gbps (Option 1) Ethernet capability. A further 1Gbps Ethernet backplane connection is available on the ATCA update channel. External network connectivity includes 10/100/1000Base-T Ethernet via RJ-45 connector on the blade faceplate. Several rear transition module (RTM) configurations support up to six additional 10/100/1000Base-T connections or up to six 10Gb Ethernet SFP+ interfaces.

Processor Complex

Both Intel® Xeon® processors L5638 are connected together via QPI interconnect to share memory resources. The processors can access the entire I/O subsystem via the Intel® 5520 chipset I/O hub. The I/O subsystem consists of:

- Intel® I/O Controller Hub ICH10R
- Intel® 82572 Gigabit Ethernet controller
- Intel® 82576 dual Gigabit Ethernet controllers
- Intel® 82599 dual 10 Gigabit Ethernet controller
- Intel® 82580 dual Gigabit Ethernet controller (on optional RTM)
- Intel® 82599 dual 10 Gigabit Ethernet controller (on optional RTM)
- Intel® i350 quad Gigabit Ethernet controller (on optional RTM)
- LSI Logic LSISAS1064E SAS controller (on optional RTM)

Software Support

The ATCA-7365 blade can be configured with a variety of software offerings, from firmware-only to fully integrated and verified software operating environments.

FIRMWARE

Firmware-only blade-level support is offered for customers taking on the integration and verification responsibilities. It provides all the boot and IPMC firmware required for an ATCA blade.

The BIOS firmware includes support for:

- Unified Extensible Firmware Interface (UEFI)
- Power management support, ACPI 3.0b
- Multiple boot options including:
 - Local and external hard disks
 - On-board flash disk
 - External USB boot media
 - PXE boot via ATCA base interface
 - iSCSI boot via ATCA base interface with operating systems supporting UEFI
- RAID 0/1 support via LSI SAS BIOS extension
- Serial redirection of the BIOS console
- Serial over LAN of the BIOS console via ATCA base interface
- BIOS upgrade via local host

INTELLIGENT PLATFORM MANAGEMENT CONTROL

The ATCA-7365 features an intelligent platform management controller (IPMC). The IPMC is a management subsystem providing monitoring, event logging, and recovery control. The IPMC serves as the gateway for management applications to access the platform hardware. Features include:

- Compliance with PICMG 3.0 and IPMI 1.5
- Rollback capability if IPMC image upgrade failed
- Firmware (BIOS, IPMC, FPGA) upgradable from IPMI interface (IPMB) and/or locally, PICMG HPM.1 support or via Basic Blade Services (BBS) firmware upgrade utility
- Support for serial port redirection over LAN interface (IPMI 2.0 compliant)

SUPPORTED OPERATING SYSTEMS

- Red Hat RHEL 5.5, 6.0 and 6.2 certified
- Wind River PNE LE 3.0
- Prepared for Microsoft® Windows® Server 2008
- VMware ESX/ESXi 4.1 and ESXi 5.1 certified (requires VGA module)

To better exploit the CPU and I/O resources of the blade, RHEL supports CPU and I/O virtualization using XEN/KVM. In addition RHEL provides code for enabling the processor power management to help enhancing energy efficiency of the blade.

Artesyn ATCA blades can be configured with optional software that includes Basic Blade Services. When integrated in one of the Artesyn ATCA Centellis™ platforms, the ATCA-7365 comes complete with, and is verified with, Wind River PNE 3.0. This distribution comes with all Linux Support Packages (LSPs) to support Artesyn ATCA blades as well as user applications. Basic Blades Services (BBS) software is provided to enable a set of ATCA hardware and software components into a fully integrated and verified telecom platform – the Centellis® platform. This platform is ready for customers HA middleware and application environment.

Basic Blade Services include:

- Hardware Platform Management including local IPMC, LED, E-Keying and blade extraction software
- Firmware upgrade utility
- Local management access (CLI)

RELEVANT STANDARDS

- Linux Foundation
- Service Availability Forum™ (SA Forum)
 - Hardware Platform Interface (HPI) – HPI-B.02

Please check with your local sales contact for availability of supported Centellis® platforms.

Rear Transition Modules

Several RTM variants are available to support different I/O configurations at the RTM faceplate.

RTM-ATCA-7360 includes:

- One (1) USB 2.0 interface
- Six (6) Gigabit Ethernet interfaces, 10/100/1000Base-T, RJ-45 connector
- Two (2) SAS interfaces, SFF-8470 connector
- Disk bay for one (1) hot-swappable hard disk, 2.5"

RTM-ATCA-7360-L includes:

- One (1) USB 2.0 interface
- Two (2) Gigabit Ethernet interfaces, 10/100/1000Base-T, RJ-45 connector
- Two (2) SAS interfaces, SFF-8470 connector
- Disk bay for one (1) hot-swappable hard disk, 2.5"

RTM-ATCA-736X-DD supports:

- Two (2) Gigabit Ethernet interfaces, 10/100/1000Base-T, RJ-45 connectors
- Two (2) disk bays for hot-swappable hard disks, 2.5"

RTM-ATCA-736X-10G supports:

- Four (4) 10 Gigabit Ethernet interfaces, SFP+/SFP
- Four (4) Gigabit Ethernet interfaces 10/100/1000Base-T, RJ-45 connectors
- Two (2) SAS interfaces, SFF-8470 connector
- Disk bay for one (1) optional hot-swappable hard disk, 2.5"

RTM-ATCA-736X-10G-SP supports:

- Six (6) 10 Gigabit Ethernet interfaces, SFP+/SFP
- Four (4) Gigabit Ethernet interfaces, 10/100/1000Base-T, RJ-45 connectors

Hardware

PROCESSOR

- Two 6-core Intel® Xeon® L5638 (2.0 GHz) processors
- QuickPath Interface (QPI) – 5.86 GT/s
- 12MB L3 cache (per processor)
- 64-bit mode extension (EM64T)
- SMP support

MEMORY

- DDR3-800/1066/1333 memory controllers integrated into processors
- Total of six independent memory channels
- From 4 to 192GB memory configurations supported
- 4MB primary firmware flash, 4MB redundant flash for failsafe operation

MASS STORAGE

- Embedded USB flash disk, 4GB (higher capacity upon request)
- On-board solid state disk at SATA, 128GB or 256GB (optional)
- Hot-swappable hard disk on RTM
- Hard disk drive options including
 - Enterprise class disks (various capacity options)
 - 80GB SATA disk with extended temperature range

BASE AND FABRIC INTERFACES

- Dual star configuration
- PICMG 3.0 base interface compliant, Gigabit Ethernet (1.0Gbps)
- PICMG 3.1 fabric interface compliant
 - PICMG 3.1, Option 1 – Single, redundant Gigabit Ethernet pair (1.0Gbps)
 - PICMG 3.1, Option 9 – Single, redundant 10 Gigabit Ethernet pair (10Gbps)
- PICMG 3.0 Update Channel Gigabit Ethernet (1.0Gbps)

COUNTERS/TIMERS

- Real-time clock
- Programmable watchdog timer

EXTERNAL INTERFACES

- Front panel
 - 10/100/1000Base-T Ethernet (1), RJ-45
 - Serial console (1), RJ-45
 - USB 2.0 (2)
 - Optional VGA interface
- Rear transition module
 - USB 2.0 (1)
 - Gigabit Ethernet interfaces (up to 6), optional, RJ-45. Note 1
 - SAS interfaces (2), SFF-8470
 - 10 Gigabit Ethernet interfaces (2 or 6), optional, SFP+

POWER REQUIREMENTS

- Dual-redundant –48 to –60 VDC (TNV-2) rail
- Input range: –39 to –72 VDC
- Power consumption including RTM
 - Typical: 180 - 220 W
 - Maximum: 260 W

THERMAL CHARACTERISTICS

- Operating range: –5 °C to 55 °C
- Airflow requirements according to CP-TA B.4 (B.3 with specific configurations)

RELEVANT BLADE SIZE

- 8U form factor, 280 mm X 322.5 mm, single slot

RELEVANT STANDARDS

- PICMG 3.0 (form factor, IPMI, base interface, hot swap, RTM)
- PICMG 3.1, Option 1, 9

Note 1: The number of interfaces depends from the RTM variant

Ordering Information

<i>Part Number</i>	<i>Description</i>
ATCA-7365-D-24GB	ATCA processor blade, dual L5638 6-core (2.0 GHz), 12X DIMM sockets, 6X 4GB, 10G support
ATCA-7365-D-24GB-V	ATCA processor blade, dual L5638 6-core (2.0 GHz), 12X DIMM sockets, 6X 4GB, 10G support, on-board VGA module
ATCA-7365-D-48GB	ATCA processor blade, dual L5638 6-core (2.0 GHz), 12X DIMM sockets, 6X 8GB, 10G support
ATCA-7365-D-48GB-V	ATCA processor blade, dual L5638 6-core (2.0 GHz), 12X DIMM sockets, 6X 8GB, 10G support, on-board VGA module.
ATCA-7365-D-0GB	ATCA processor blade, dual L5638 6-core (2.0 GHz), 12X DIMM sockets, 0GB, 10G support. See Note 1
ATCA-7365-D-0GB-V	ATCA processor blade, dual L5638 6-core (2.0 GHz), 12X DIMM sockets, 0GB, 10G support, on-board VGA module. See Note 1
ATCA-7XMEM-1333-4G	4GB DDR3-1333 VLP memory module for ATCA-736X product series
ATCA-7XMEM-1333-8G	8GB DDR3-1333 VLP memory module for ATCA-736X product series
RTM-ATCA-7360	RTM for the ATCA-736X product series, 6X GbE, 2X SAS, 1X slot for optional HDD
RTM-ATCA-7360-L	RTM for the ATCA-736X product series, 2X GbE, 2X SAS, 1X slot for optional HDD
ATCA7360-HDD2-SAS	300GB SAS HDD kit for the RTM-ATCA-7360. See Note 2
ATCA7360-HDD4-SAS	600GB SAS HDD kit for the RTM-ATCA-7360. See Note 2
ATCA7360-HDD3-SATA	80GB SATA HDD (ext. temp.) kit for the RTM-ATCA-7360. See Note 2
RTM-ATCA-7360-HDDKIT	Carrier and mounting kit for HDD or SSD devices used with RTM-ATCA-7360 or RTM-ATCA-7360-L (no disk included)
RTM-ATCA-736X-DD	RTM for the ATCA-736X product series, 2X GbE, 2X slot for optional HDD
RTM-ATCA-736X-DD-600	RTM for the ATCA-736X product series, 2X GbE, 2X 300GB SAS HDD included
RTM-ATCA-736X-DD-1K2	RTM for the ATCA-736X product series, 2X GbE, 2X 600GB SAS HDD included
RTM-ATCA-736X-10G	RTM for the ATCA-7365, ATCA-737X and ATCA-747X product series, 4x 10GbE (SFP+), 4x GbE, 1x slot for optional HDD
ATCA736X-HDD1-SAS	300GB SAS HDD for the RTM-ATCA-736X-10G
ATCA736X-HDD2-SAS	600GB SAS HDD for the RTM-ATCA-736X-10G
ATCA736X-SSD1-SATA	480 GB SATA SSD kit for the RTM-ATCA-736X-10G
RTM-ATCA-736X-10G-SP	RTM for the ATCA-7365, ATCA-737X and ATCA-747X product series, 6x 10GbE (SFP+), 4x GbE
ATCA7365-MMOD-SSDKIT	ATCA-7365 memory module SSD kit, 1x optional SSD
ATCA7365-MMOD-SATA1	ATCA-7365 memory module SSD kit, with 128GB SSD, MLC
ATCA-7XMMOD-SATA4	256GB Slim SATA (MO-297) MLC Module for ATCA-737X and ATCA-747X product series
RJ45-DSUB-ATCA	RJ-45 DSUB cable for the ATCA-7140, 7X50, 736X, 737X, 747X blades
SA-BBS-WR30-7360	DVD - BBS SW and WR PNE 3.0 for ATCA-7360 and ATCA-7365. See Note 3
SA-BBS-WR42-7360	DVD - BBS SW and WR Linux 4.2 for ATCA-7360 and ATCA-7365. See Note 3

Note 1: No memory installed

Note 2: Optional carrier kit for RTM-ATCA-7360 and RTM-ATCA-7360-L

Note 3: License for a single blade

Regulatory Compliance

Item	Description
Designed to comply with NEBS, Level 3	Telcordia GR-63-CORE, NEBS Physical Protection
	Telcordia GR-1089-CORE, Electromagnetic Compatibility and Electrical Safety – Generic Criteria for Network Telecommunications Equipment. Equipment Type 2
Designed to comply with ETSI	ETSI Storage, EN 300 019-1-1, Class 1.2 equipment, Not Temperature Controlled Storage Locations
	ETSI Transportation, EN 300 019-1-2, Class 2.3 equipment, Public Transportation
	ETSI Operation, EN 300 019-1-3, Class 3.1(E) equipment, Temperature Controlled Locations
	ETSI EN 300 132-2 Environmental Engineering (EE); Power supply interface at the input to telecommunications equipment; Part 2: Operated by direct current (dc)
	ETSI ETS 300 753, Equipment Engineering (EE); Acoustic noise emitted by telecommunications equipment
CE Conformity	Directive 2004/108/EC, Directive 2006/95/EC
EMC	ETSI EN 300 386 Electromagnetic compatibility and Radio spectrum Matters (ERM); telecommunication network equipment; ElectroMagnetic Compatibility (EMC) requirements, Telecommunication equipment room (attended)
	CFR 47 FCC Part 15 Subpart B, Class A (US); FCC Part 15 - Radio Frequency Devices; Subpart B: Unintentional Radiators
	AS/NZS CISPR 22 (Australia/New Zealand), Limits and Methods of Measurement of Radio Disturbance Characteristics of Information Technology Equipment
	VCCI Class A (Japan), Voluntary Control Council for Interference by Information Technology Equipment
	CISPR 22 Information technology equipment – Radio disturbance characteristics – Limits and methods of measurement
	CISPR 24 Information technology equipment – Immunity characteristics – Limits and methods of measurement
Safety	Certified to UL/CSA 60950-1, EN 60950-1 and IEC 60950-1 CB Scheme
	Safety of information technology equipment, including electrical business equipment
RoHS/WEEE compliance	DIRECTIVE 2002/95/EC OF THE EUROPEAN PARLIAMENT AND OF THE COUNCIL on the restriction of the use of certain hazardous substances in electrical and electronic equipment (RoHS)
	DIRECTIVE 2002/96/EC OF THE EUROPEAN PARLIAMENT AND OF THE COUNCIL on waste electrical and electronic equipment (WEEE)
Interoperability	Designed to operate within a CP-TA B.4 system environment at full performance

SOLUTION SERVICES

Artesyn Embedded Technologies provides a portfolio of solution services optimized to meet your needs throughout the product lifecycle. Design services help speed time-to-market. Deployment services include global 24x7 technical support. Renewal services enable product longevity and technology refresh.

WORLDWIDE OFFICES

United States	+1 888 412 7832	Japan	+81 3 5403 2730
Hong Kong	+852 2176 3540	Korea	+82 2 6004 3268
China	+86 400 8888 183		



www.artesyn.com

ATCA-7365-DS 14Jul2017

X-ON Electronics

Largest Supplier of Electrical and Electronic Components

Click to view similar products for [Single Board Computers](#) category:

Click to view products by [Artesyn Embedded Technologies](#) manufacturer:

Other Similar products are found below :

[MANO882VPGGA-H81](#) [SSD3200W-S-SLC-INN](#) [AmITX-SL-G-Q170](#) [IB100](#) [MVME61006E-2173R](#) [20-101-0738](#) [PCE-4128G2-00A1E](#)
[RSB-4220CS-MCA1E](#) [SHB230DGGA-RC](#) [IB909AF-5650](#) [AmITX-BT-I-E3815](#) [PICO841VGA-E3827](#) [IMB210VGGA](#) [MI981AF](#) [RSB-](#)
[4221CS-MCA1E](#) [PCE-9228G2I-00A1E](#) [IB915F-3955](#) [IB909F-5010](#) [MI958F-16C](#) [UPS-P-8G-64GB-PACK](#) [S2600WFT](#) [IB915AF-6300](#)
[S2600STB](#) [BBS2600BPS](#) [IB915F-6100](#) [Nit6QP_MAX](#) [MI990VF-X28-E](#) [MI990VF-6820](#) [MI991AF-C236](#) [94AC6636](#) [BANANA PI BPI-M4](#)
[BLKNUC7I3DNHNC1978015](#) [BLKNUC7I5DNK1E 960791](#) [IOT-LS1012A-OXALIS](#) [NITX-300-ET-DVI](#) [94AC6633](#) [A33-OLINUXINO-](#)
[N8G](#) [A64-OLINUXINO-1GE16GW](#) [A20-SOM-E16GS16M](#) [A20-SOM204-1G-M](#) [EMB-APL1-A10-3350-F1-LV](#) [PICO-APL1-A10-F001](#)
[PICO-APL4-A10-F003](#) [ODYSSEY - STM32MP157C BOARD WITH SOM](#) [BEAGLEBONE GREEN GATEWAY DEV BOARD](#) [ODYSSEY](#)
[- X86J4105864 8GB RAM 64GB EMMC](#) [ODYSSEY -X86J4105864 8GB/64GB ENTERPRISE](#) [VISIONDK-STM32MP1 V.1.0](#) [VISIONDK-](#)
[6ULL V.2.0](#) [VISIONDK-8MMINI V.1.0](#)