

SIL/SMT40C2 Series

C-Class Non-Isolated

Data Sheet

Total Power: 40 Amps
Input Voltage: 4.5 - 13.8 Vdc
of Outputs: Single

SPECIAL FEATURES

- 40 A current rating
- Input voltage range: 4.5 - 13.8 Vdc
- Output voltage: 0.6 - 5 V
- Industry-leading value
- Cost optimized design
- Excellent transient response
- Output enable
- output voltage adjustability
- path for future upgrades
- Supports silicon voltage migration
- Reduced design-in and qual time
- RoHS compliant

SAFETY

- UL, cUL CAN/CSA 22.2 No. E139421 UL6950 File No. TBD
- TÜV Product Service (EN60950)
- Certificate No. TBD
- CB report and certificate to IEC60950



Electrical Specifications

Input		
Input voltage range		4.5 - 13.8 Vdc
Input current	Minimum load Remote OFF	50 mA 5 mA
Input current (max.)	See Note 3	25 A @ I _o max.
Start-up time	Remote ON/OFF	3 ms
Output		
Output voltage	See Note 5	0.6 - 5 V
Output setpoint accuracy	0.1% trim resistors	±1.0%
Line regulation	Low line to high line	±0.2%
Load regulation	Full load to min. load	±0.5%
Min./max. load		0 A/40 A
Overshoot	At turn-on	0.5% max.
Undershoot	At turn-off	100 mV max.
Ripple and noise 5 Hz to 20 MHz	See Note 1	25 mV V _{in} = 5 V, V _{out} = 2.5 V
Transient response	See Note 1, 2	130 mV max. deviation 50 μs recovery to within regulation band
General		
Efficiency (high input)	V _{in} = 5 V, V _o = 2.5 V, I _o = 20 A	94%
Switching frequency	Fixed	500 kHz
Material flammability		UL94V-0
Weight		17 g (0.06 oz.)
MTBF	12 V @ 40 °C, 100% load Bellcore 332	6,749,409 hours
Coplanarity	Surface mount models	150 μm

Environmental Specifications

Thermal performance	Operating ambient temperature	-0 °C to +70 °C
See Note 5	Non-operating temperature	-40 °C to +125 °C
Protection		
Short-circuit	Hiccup, non-latching	
Oversoltage protection	Hiccup, non-latching	
Recommended System Capacitance		
Input	See Note 6	0 μF
Output	See Note 7	0 μF

Ordering Information

Model Number ^(3,5)	Input Voltage	Output Voltage	Output Current (Min.)	Output Current (Max.)	Efficiency (Typical)	Regulation	
						Line	Load
SIL40C2-00SADJ-VJ	4.5 - 13.8 Vdc	0.6 - 5 V	0 A	40 A	94%	±0.2%	±0.5%
SIL40C2-00SADJHJ	4.5 - 13.8 Vdc	0.6 - 5 V	0 A	40 A	94%	±0.2%	±0.5%
SMT40C2-00SADJJ	4.5 - 13.8 Vdc	0.6 - 5 V	0 A	40 A	94%	±0.2%	±0.5%

Part Number System with Options

Product Family	Rated Output Current	Performance	Generation	Input Voltage	Output Voltage	Mounting Option	RoHS Compliance
SIL <small>SIL = Single In Line SMT = Surface Mount</small>	40 <small>06 = 6 Amp 15 = 15 Amp 20 = 20 Amp 30 = 30 Amp 40 = 40 Amp</small>	C <small>C = Cost Optimized</small>	2 <small>Blank = Standard 2 = Increased current density</small>	00 <small>00 = 4.5 - 13.8 V</small>	SADJ <small>Single Adjustable Output</small>	V <small>V = Vertical H = Horizontal (Applicable to SIL version only)</small>	J <small>J = Pb free (RoHS 6/6 compliant)</small>

Output Voltage Adjustment

The ultra-wide output voltage trim range offers major advantages to users who select the SIL40C2 series. It is no longer necessary to purchase a variety of modules in order to cover different output voltages. The output voltage can be trimmed in a range of 0.6-5 V. When the SIL40C2 converter leaves the factory, the output has been adjusted to the default voltage of 0.6 V.

Notes:

1. Measured as per recommended system capacitance.
2. di/dt = 10 A/μs, Vin = Nom, Tc = 25 °C, load change = 0.75 Io to full Io and full Io to 0.75.
3. External input fusing is recommended.
4. Additional part numbers may be available with different output voltages.
5. Airflow dependent, 100 LFM minimum required.
6. No capacitors needed for ripple current stability.
7. No capacitors needed for stability.
8. NOTICE: Some models do not support all options. Please contact your local Artesyn Embedded Technologies representative or use the on-line model number search tool at <http://www.Artesyn.com/power> to find a suitable alternative.
9. To order a Horizontal Mounting option with a pin length of 0.165", please use model SIL40C2-00S-HP5.

Standard Application Drawing

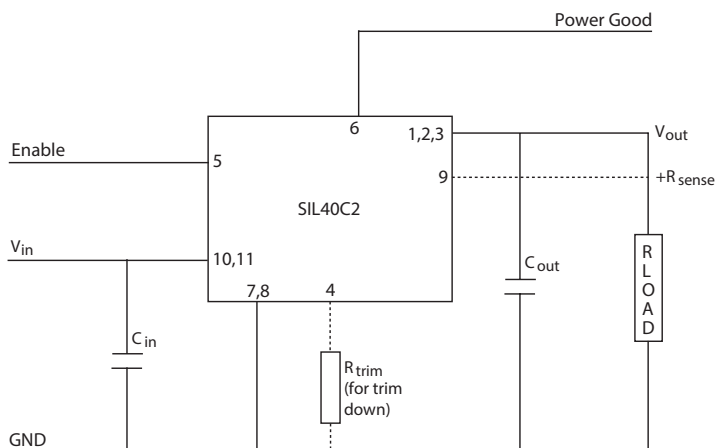

Mechanical Drawings

Vertical Mount

Dimensions in inches (mm). Tolerances (unless otherwise specified) 2 Places ± 0.030 (± 0.76) 3 Places ± 0.010 (± 0.25)

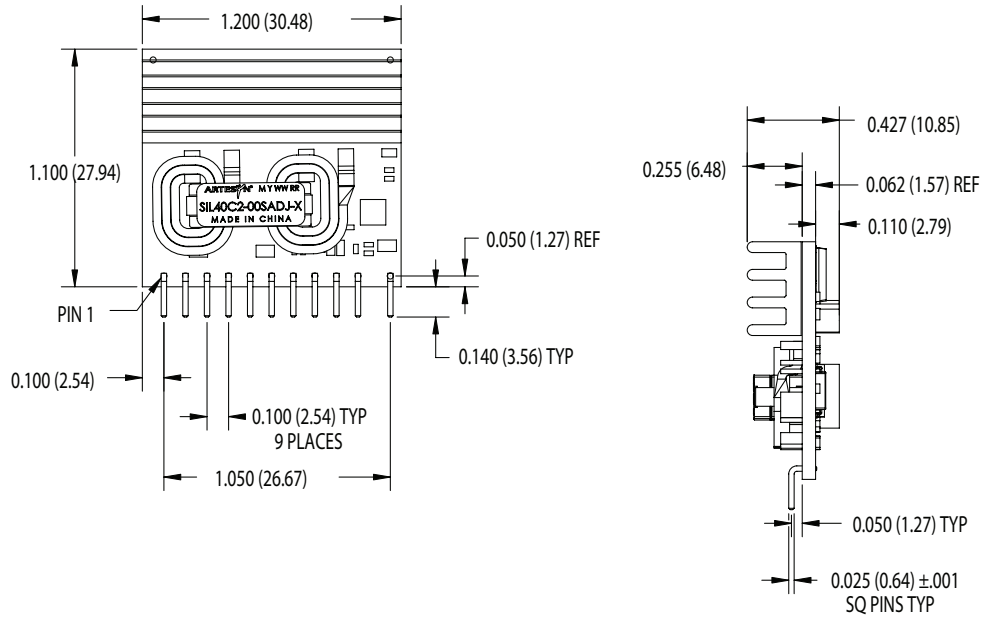

Horizontal Mount

Dimensions in inches (mm). Tolerances (unless otherwise specified) 2 Places ± 0.030 (± 0.76) 3 Places ± 0.010 (± 0.25)

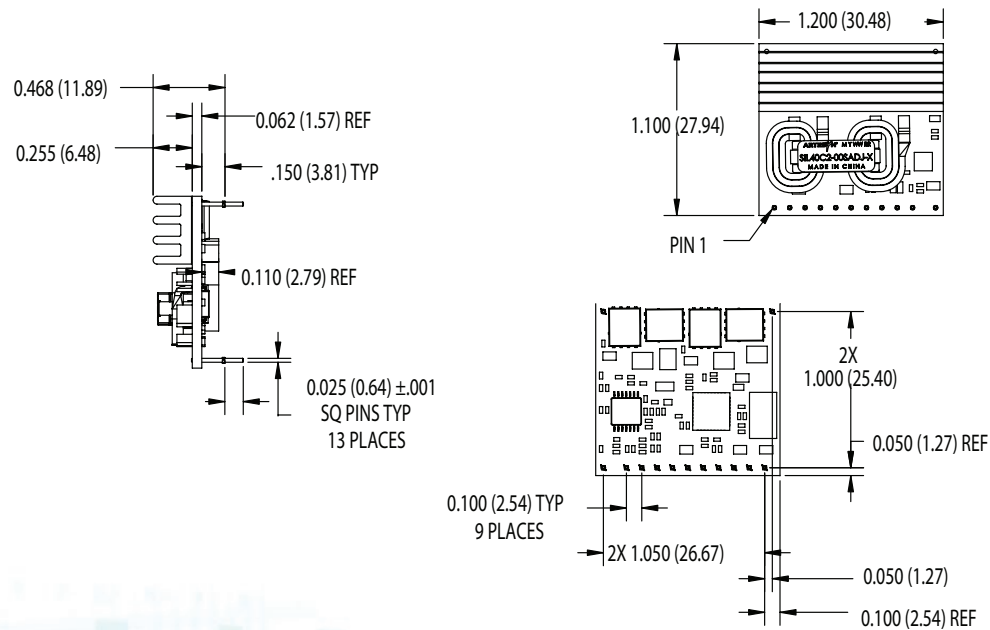

Mechanical Drawings

Surface Mount

Dimensions in inches (mm). Tolerances (unless otherwise specified) 2 Places ± 0.030 (± 0.76) 3 Places ± 0.010 (± 0.25)

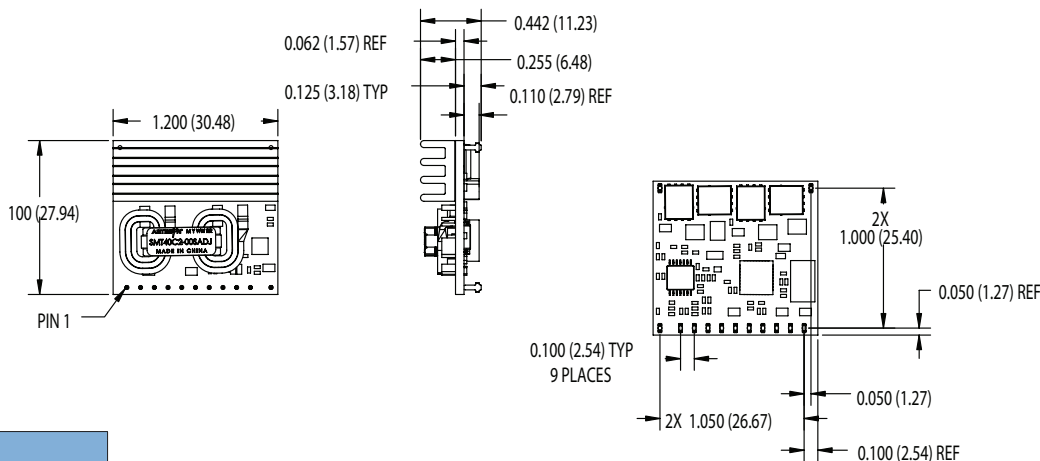

Pin Assignments

Pin	Function
1	Vout
2	Vout
3	Vout
4	Trim
5	Enable
6	Power Good
7	Ground
8	Ground
9	(+) Sense
10	Vin
11	Vin
12	Mech Pin (Horz/SMT only)
13	Mech Pin (Horz/SMT only)

WORLDWIDE OFFICES

Americas

2900 S.Diablo Way
Tempe, AZ 85282
USA
+1 888 412 7832

Europe (UK)

Waterfront Business Park
Merry Hill, Dudley
West Midlands, DY5 1LX
United Kingdom
+44 (0) 1384 842 211

Asia (HK)

14/F, Lu Plaza
2 Wing Yip Street
Kwun Tong, Kowloon
Hong Kong
+852 2176 3333

ARTESYNTM
EMBEDDED TECHNOLOGIES

www.artesyn.com

While every precaution has been taken to ensure accuracy and completeness in this literature, Artesyn Embedded Technologies assumes no responsibility, and disclaims all liability for damages resulting from use of this information or for any errors or omissions. Artesyn Embedded Technologies, Artesyn and the Artesyn Embedded Technologies logo are trademarks and service marks of Artesyn Embedded Technologies, Inc. All other names and logos referred to are trade names, trademarks, or registered trademarks of their respective owners. © 2015 Artesyn Embedded Technologies, Inc.

For more information: www.artesyn.com/power
For support: productsupport.ep@artesyn.com

X-ON Electronics

Largest Supplier of Electrical and Electronic Components

Click to view similar products for [Non-Isolated DC/DC Converters](#) category:

Click to view products by [Artesyn Embedded Technologies](#) manufacturer:

Other Similar products are found below :

[PSR152.5-7IR](#) [APTH003A0X-SRZ](#) [SPM1004-3V3C](#) [R-785.0-05](#) [10E24-P15-10PPM](#) [1E24-P4-25PPM-SHV-5KV](#) [PROPOWER-3.3V](#)
[MYGTM01210BZN](#) [40C24-N250-I5-H](#) [40A24-P30-E](#) [3V12-P0.8](#) [10C24-N250-I10-AQ-DA](#) [4AA24-P20-M-H](#) [3V12-N0.8](#) [3V24-P1](#) [3V24-](#)
[N1](#) [BMR4672010/001](#) [BMR4652010/001](#) [6AA24-P30-I5-M](#) [6AA24-N30-I5-M](#) [BM2P101X-Z](#) [35A24-P30](#) [2.5M24-P1](#) [PTV03010WAD](#)
[PTV05020WAH](#) [PTV12010LAH](#) [PTV12020WAD](#) [R-7212D](#) [R-7212P](#) [R-78AA15-0.5SMD](#) [R-78AA5.0-1.0SMD](#) [30A24-N15-E](#) [10A12-P4-](#)
[M](#) [10C24-N250-I5](#) [10C24-P125](#) [10C24-P250-I5](#) [6A24-P20-I10-F-M-25PPM](#) [1A24-P30-F-M-C](#) [TSR 1-24150SM](#) [1/2AA24-N30-I10](#) [1C24-](#)
[N125](#) [12C24-N250](#) [V7806-1500](#) [PTV12020LAH](#) [PTV05010WAH](#) [PTN04050CAZT](#) [PTH12020WAD](#) [PTH12020LAS](#) [PTH05050YAH](#)
[PTH05T210WAH](#)