



AK4556

3V 192kHz 24Bit $\Delta\Sigma$ CODEC

GENERAL DESCRIPTION

The AK4556 is a low voltage 24bit 192kHz CODEC for high performance battery powered digital audio subsystems. The dynamic performance to power supply voltage ratio is very high, attaining 103dB and 106dB SNR for ADC and DAC, respectively. Sampling rates up to 216kHz are supported. The AK4556 reduces jitter sensitivity by using an integrated switched-capacitor filter. The analog inputs and outputs are single-ended to minimize pin count and external filtering requirements. Packaged in a very small 20-pin TSSOP, the AK4556 is ideal for space-sensitive applications.

FEATURES

- Single-ended ADC**
 - Dynamic Range, S/N: 103dB@VA=3.0V
 - S/(N+D): 91dB@VA=3.0V
 - HPF for DC-offset cancel (fc = 1Hz @ fs=48kHz)
 - HPF can be disabled
- Single-ended DAC**
 - Dynamic Range, S/N: 106dB@VA=3.0V
 - S/(N+D): 90dB@VA=3.0V
 - Digital de-emphasis for 32kHz, 44.1kHz and 48kHz sampling
- Audio I/F format: MSB First, 2's Complement**
 - ADC: 24bit MSB justified or I²S compatible
 - DAC: 24bit MSB justified, 24bit LSB justified or I²S compatible
- Input/Output Voltage: ADC = 2.1Vpp @ VA=3.0V**
DAC = 2.1Vpp @ VA=3.0V
- Master/Slave mode**
- Sampling Rate:**
 - Normal Speed: 8kHz to 54kHz (256fs or 512fs)
8kHz to 48kHz (384fs or 768fs)
 - Double Speed: 54kHz to 108kHz (256fs)
48kHz to 96kHz (384fs)
 - Quad Speed: 108kHz to 216kHz (128fs)
96kHz to 192kHz (192fs)
- Master Clock:**
 - Slave mode: 256fs, 384fs, 512fs or 768fs (Normal Speed)
256fs or 384fs (Double Speed)
128fs or 192fs (Quad Speed)
 - Master mode: 256fs or 512fs (Normal Speed)
256fs (Double Speed)
128fs (Quad Speed)
- Power Supply: 2.4 to 3.6V (Normal Speed, Double Speed)**
2.7 to 3.6V (Quad Speed)
- Power Supply Current: 27.5mA**
- Ta = -40 to 85°C**
- Very Small Package: 20-pin TSSOP**
- Upper compatible with AK4552**

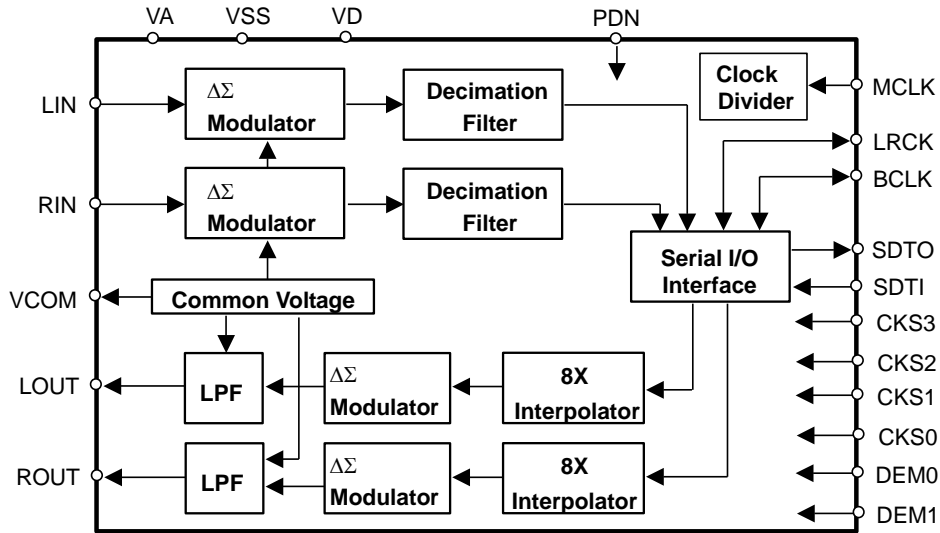

Figure 1. Block Diagram

■ Compatibility with the AK4552

1. Function

Function		AK4552	AK4556
fs (max)		100kHz	216kHz
HFP Cut-off		3.7Hz @ fs = 48kHz	1Hz @ fs = 48kHz
HPF Disable		No	Yes
ADC			
Input Level		0.617 x VA	0.7 x VA
Input Resistance		34kΩ @ fs = 44.1kHz, 24kΩ @ fs = 96kHz	8kΩ @ fs = 48kHz, 96kHz, 192kHz
Init Cycle		2081/fs	4134/fs @ Normal Speed, Slave mode
S/(N+D)		89dB	91dB
DR, S/N		97dB	103dB
DF	SA	65dB	68dB
	SB	29.4kHz	28kHz
	GD	17/fs	18/fs
DAC			
Output Level		0.583 x VA	0.7 x VA
Road Resistance		10kΩ	5kΩ
S/(N+D)		88dB	90dB
DR, S/N		100dB	106dB
DF	SA	43dB	54dB
	GD	15.4/fs	21/fs
MCLK (Slave)		256/384/512/768fs @ Normal Speed mode 256/384fs @ Double Speed Mode 128/192fs @ Double Speed Monitor 64/96/128/192fs @ Quad Speed Monitor	256/384/512/768fs @ Normal Speed 256/384fs @ Double Speed 128/192fs @ Quad Speed
Monitor Mode		Yes (Double / Quad)	No
M/S mode		Slave	Master / Slave
Audio I/F	ADC	24bit MSB justified	24bit MSB justified / I ² S
	DAC	24bit LSB justified	24bit MSB justified / 24bit LSB justified / I ² S
I _{dd} (V _{dd} = 3V)		14mA	27.5mA
V _{DD}		2.4V to 4.0V	2.4V to 3.6V (Normal/Double Speed) 2.7V to 3.6V (Quad Speed)
Package		16TSSOP (5.0mm x 6.4mm, 0.65mm Pitch)	20TSSOP (6.5mm x 6.4mm, 0.65mm Pitch)

2. Pin Layout

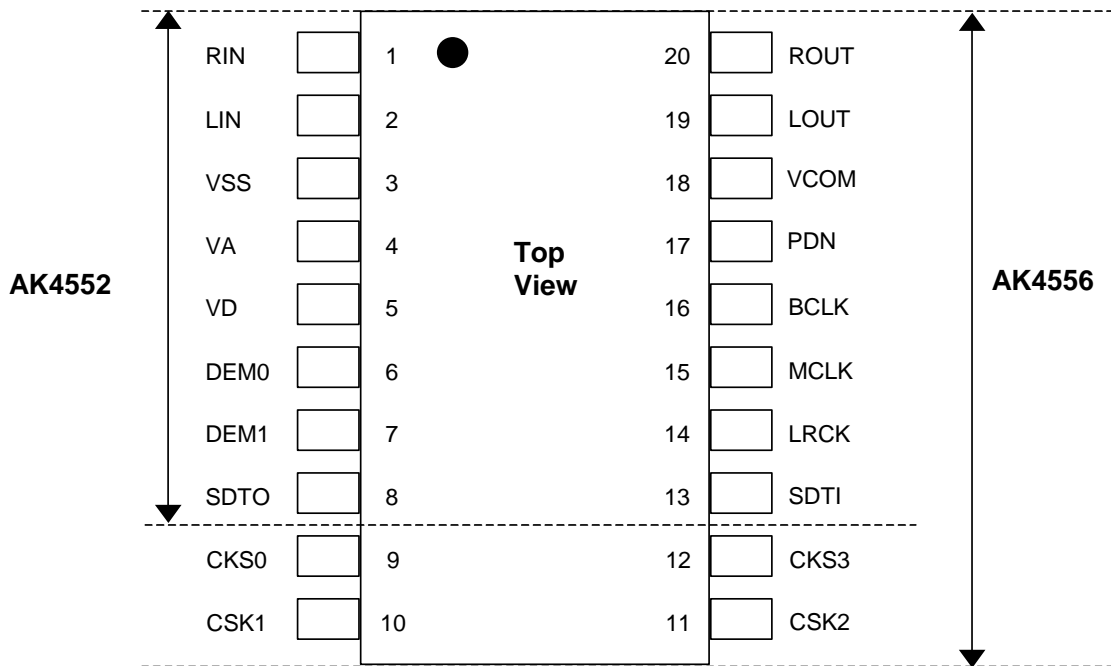

■ Ordering Guide

AK4556VT
AKD4556-40 ~ +85°C
Evaluation Board for AK4556

20-pin TSSOP (0.65mm pitch)

■ Pin Layout

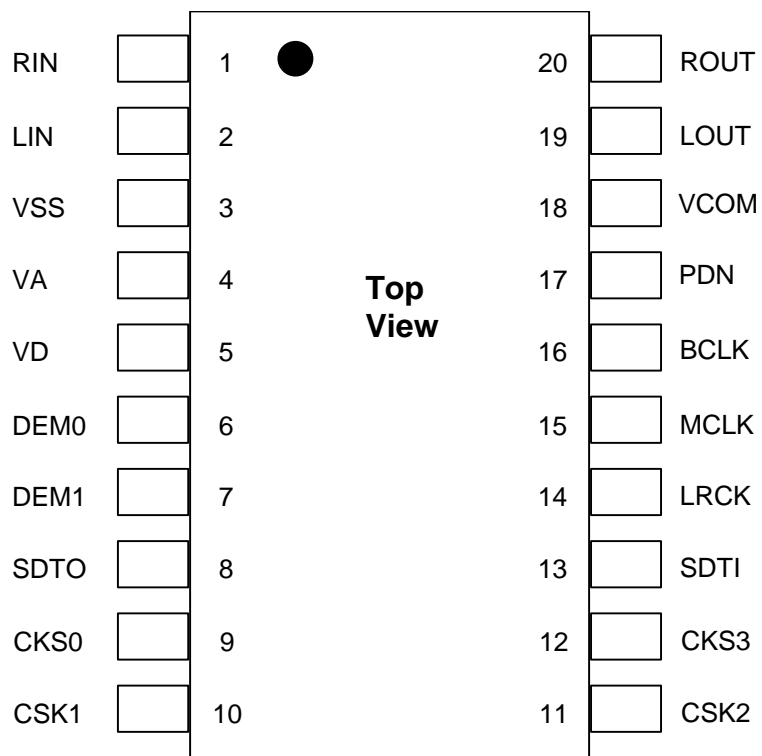

PIN/FUNCTION

No.	Pin Name	I/O	Function
1	RIN	I	Rch Analog Input Pin
2	LIN	I	Lch Analog Input Pin
3	VSS	-	Ground Pin
4	VA	-	Analog Power Supply Pin
5	VD	-	Digital Power Supply Pin
6	DEM0	I	De-emphasis Control Pin
7	DEM1	I	De-emphasis Control Pin
8	SDTO	O	Audio Serial Data Output Pin When PDN pin is "L", SDTO pin outputs "L".
9	CKS0	I	Mode Setting Pin #0
10	CSK1	I	Mode Setting Pin #1
11	CSK2	I	Mode Setting Pin #2
12	CSK3	I	Mode Setting Pin #3
13	SDTI	I	Audio Serial Data Input Pin
14	LRCK	I/O	Input/Output Channel Clock Pin When PDN pin is "L", LRCK pin outputs "L" in master mode.
15	MCLK	I	Master Clock Input Pin
16	BCLK	I/O	Audio Serial Data Clock Pin When PDN pin is "L", BCLK pin outputs "L" in master mode.
17	PDN	I	Power-Down & Reset Mode Pin "L": Power-down and Reset, "H": Normal operation The AK4556 should be reset once by bringing PDN pin = "L".
18	VCOM	O	Common Voltage Output Pin, 0.5 x VA
19	LOUT	O	Lch Analog Output Pin When PDN pin is "L", LOUT pin becomes Hi-Z.
20	ROUT	O	Rch Analog Output Pin When PDN pin is "L", ROUT pin becomes Hi-Z.

Note: Do not allow digital input pins except analog input pins (LIN and RIN) to float.

■ Handling of Unused Pin

The unused I/O pin should be processed appropriately as below.

Classification	Pin Name	Setting
Analog Input	LIN, RIN	These pins should be open.
Analog Output	LOUT, ROUT	These pins should be open.

ABSOLUTE MAXIMUM RATINGS

(VSS=0V; Note 1)

Parameter		Symbol	Min.	Max.	Unit
Power Supplies	Analog	VA	-0.3	4.6	V
	Digital	VD	-0.3	4.6	V
Input Current (Any Pin Except Supplies)		IIN	-	±10	mA
Analog Input Voltage (LIN, RIN pin)		VINA	-0.3	VA+0.3	V
Digital Input Voltage (Note 2)		VIND	-0.3	VD+0.3	V
Ambient Temperature (power applied)		Ta	-40	85	°C
Storage Temperature		Tstg	-65	150	°C

Note 1. All voltages with respect to ground.

Note 2. DEM1, DEM0, CKS3, CKS2, CKS1, CKS0, SDTI, LRCK, BCLK, MCLK and PDN pins

WARNING: Operation at or beyond these limits may results in permanent damage to the device.

Normal operation is not guaranteed at these extremes.

RECOMMENDED OPERATING CONDITIONS (Normal/Double Speed)

(VSS=0V; Note 1)

Parameter		Symbol	Min.	Typ.	Max.	Unit
Power Supplies (Note 3)	Analog	VA	2.4	3.0	3.6	V
	Digital	VD	2.4	3.0	3.6	V
	Difference	VD - VA	-	-	0.3	V

RECOMMENDED OPERATING CONDITIONS (Quad Speed)
--

(VSS=0V; Note 1)

Parameter		Symbol	Min.	Typ.	Max.	Unit
Power Supplies (Note 3)	Analog	VA	2.7	3.0	3.6	V
	Digital	VD	2.7	3.0	3.6	V
	Difference	VD - VA	-	-	0.3	V

Note 1. All voltages with respect to ground.

Note 3. The power up sequence between VA and VD is not critical.

*AKM assumes no responsibility for the usage beyond the conditions in this data sheet.

ANALOG CHARACTERISTICS

(Ta=25°C; VA=VD=3.0V; VSS=0V; fs=48kHz, 96kHz, 192kHz; Signal Frequency=1kHz; BCLK=64fs; Data=24bit
Measurement frequency=20Hz ~ 20kHz at fs=48kHz, 40Hz ~ 40kHz at fs=96kHz, 40Hz ~ 40kHz at fs=192kHz; unless otherwise specified)

Parameter		Min.	Typ.	Max.	Unit	
ADC Analog Input Characteristics:						
Resolution		-	-	24	Bits	
Input Voltage	(Note 4)	1.9	2.1	2.3	Vpp	
S/(N+D)	fs=48kHz BW=20kHz	-1dBFS	82	91	-	dB
		-60dBFS	-	40	-	dB
	fs=96kHz BW=40kHz	-1dBFS	80	90	-	dB
		-60dBFS	-	37	-	dB
	fs=192kHz BW=40kHz	-1dBFS	-	90	-	dB
		-60dBFS	-	37	-	dB
DR	(-60dBFS with A-weighted)	95	103	-	dB	
S/N	(A-weighted)	95	103	-	dB	
Input Resistance		6	8	-	kΩ	
Interchannel Isolation		90	110	-	dB	
Interchannel Gain Mismatch		-	0.1	0.5	dB	
Gain Drift		-	100	-	ppm/°C	
Power Supply Rejection	(Note 8)	-	50	-	dB	
DAC Analog Output Characteristics:						
Resolution		-	-	24	Bits	
Output Voltage	(Note 5)	1.9	2.1	2.3	Vpp	
S/(N+D)	fs=48kHz BW=20kHz	0dBFS	80	90	-	dB
		-60dBFS	-	43	-	dB
	fs=96kHz BW=40kHz	0dBFS	78	88	-	dB
		-60dBFS	-	40	-	dB
	fs=192kHz BW=40kHz	0dBFS	-	88	-	dB
		-60dBFS	-	40	-	dB
DR	(-60dBFS with A-weighted)	98	106	-	dB	
S/N	(A-weighted)	98	106	-	dB	
Load Capacitance	(Note 6)	-	-	30	pF	
Load Resistance	(Note 7)	5	-	-	kΩ	
Interchannel Isolation		90	110	-	dB	
Interchannel Gain Mismatch		-	0.1	0.5	dB	
Gain Drift		-	100	-	ppm/°C	
Power Supply Rejection	(Note 8)	-	50	-	dB	

Note 4. This value is the full scale (0dB) of the input voltage. Input voltage is proportional to VA voltage.

$$V_{in} = 0.7 \times V_A (V_{pp})$$

Note 5. This value is the full scale (0dB) of the output voltage. Output voltage is proportional to VA voltage.

$$V_{out} = 0.7 \times V_A (V_{pp})$$

Note 6. When LOUT/ROUT drives some capacitive load, a 220Ω resistor should be added in series between LOUT/ROUT and capacitive load. In this case, LOUT/ROUT pins can drive a capacitor of 400pF.

Note 7. For AC-load

Note 8. PSR is applied to VA and VD with 1kHz, 50mVpp. VCOM pin is connected to a 2.2μF electrolytic capacitor and a 0.1μF ceramic capacitor.

Parameter	Min.	Typ.	Max.	Unit	
Power Supplies					
Power Supply Current					
Normal Operation (PDN pin = "H")					
VA	-	19.5	29	mA	
VD (Note 9)	fs=48kHz	-	8	12	mA
	fs=96kHz	-	11	17	mA
	fs=192kHz	-	14	21	mA
Power down mode (PDN pin = "L") (Note 10)					
VA+VD	-	10	100	μA	

Note 9. These values are in slave mode. In master mode, these values are 8.3mA (typ.) @ fs=48kHz, 11.6mA (typ.) @ fs=96kHz, 15.2mA (typ.) @ fs=192kHz.

Note 10. All digital input pins are held VD or VSS.

FILTER CHARACTERISTICS (fs=48kHz)

(Ta= -40 ~ +85°C; VA, VD=2.4~ 3.6V; DEM=OFF)

Parameter	Symbol	Min.	Typ.	Max.	Unit	
ADC Digital Filter (Decimation LPF):						
Passband (Note 11)	±0.1dB	PB	0	-	18.9	kHz
	-0.2dB		-	20.0	-	kHz
	-3.0dB		-	23.0	-	kHz
Stopband (Note 11)	SB	28	-	-	kHz	
Passband Ripple	PR	-	-	±0.04	dB	
Stopband Attenuation	SA	68	-	-	dB	
Group Delay Distortion	ΔGD	-	0	-	μs	
Group Delay (Note 12)	GD	-	18	-	1/fs	
ADC Digital Filter (HPF):						
Frequency Response (Note 11)	-3dB	FR	-	1.0	-	Hz
	-0.1dB		-	6.5	-	Hz
DAC Digital Filter (LPF):						
Passband (Note 11)	±0.06dB	PB	0	-	21.8	kHz
	-6.0dB		-	24.0	-	kHz
Stopband (Note 11)	SB	26.2	-	-	kHz	
Passband Ripple	PR	-	-	±0.02	dB	
Stopband Attenuation	SA	54	-	-	dB	
Group Delay Distortion	ΔGD	-	0	-	μs	
Group Delay (Note 12)	GD	-	21	-	1/fs	
DAC Digital Filter + Analog Filter:						
Frequency Response (Note 13)	20kHz	FR	-	-0.1	-	dB

FILTER CHARACTERISTICS (fs=96kHz)

(Ta= -40 ~ +85°C; VA, VD=2.4~ 3.6V; DEM=OFF)

Parameter	Symbol	Min.	Typ.	Max.	Unit	
ADC Digital Filter (Decimation LPF):						
Passband (Note 11)	±0.1dB	PB	0	-	37.8	kHz
	-0.2dB		-	40.0	-	kHz
	-3.0dB		-	46.0	-	kHz
Stopband (Note 11)	SB	56	-	-	kHz	
Passband Ripple	PR		-	±0.04	dB	
Stopband Attenuation	SA	68	-	-	dB	
Group Delay Distortion	ΔGD	-	0	-	μs	
Group Delay (Note 12)	GD	-	18	-	1/fs	
ADC Digital Filter (HPF):						
Frequency Response (Note 11)	-3dB	FR	-	2.0	-	Hz
	-0.1dB		-	13.0	-	Hz
DAC Digital Filter (LPF):						
Passband (Note 11)	±0.06dB	PB	0	-	43.6	kHz
	-6.0dB		-	48.0	-	kHz
Stopband (Note 11)	SB	52.4	-	-	kHz	
Passband Ripple	PR	-	-	±0.02	dB	
Stopband Attenuation	SA	54	-	-	dB	
Group Delay Distortion	ΔGD	-	0	-	μs	
Group Delay (Note 12)	GD	-	21	-	1/fs	
DAC Digital Filter + Analog Filter:						
Frequency Response (Note 13)	40kHz	FR	-	-0.3	-	dB

FILTER CHARACTERISTICS (fs=192kHz)

(Ta= -40 ~ +85°C; VA, VD=2.7~ 3.6V; DEM=OFF)

Parameter	Symbol	Min.	Typ.	Max.	Unit	
ADC Digital Filter (Decimation LPF):						
Passband (Note 11)	±0.1dB	PB	0	-	56.6	kHz
	-0.2dB		-	57.0	-	kHz
	-3.0dB		-	90.3	-	kHz
Stopband (Note 11)	SB	112	-	-	kHz	
Passband Ripple	PR	-	-	±0.02	dB	
Stopband Attenuation	SA	70	-	-	dB	
Group Delay Distortion	ΔGD	-	0	-	μs	
Group Delay (Note 12)	GD	-	18	-	1/fs	
ADC Digital Filter (HPF):						
Frequency Response (Note 11)	-3dB	FR	-	4.0	-	Hz
	-0.1dB		-	26.0	-	Hz
DAC Digital Filter (LPF):						
Passband (Note 11)	±0.5dB	PB	0	-	87.0	kHz
	-6.0dB		-	96.0	-	kHz
Stopband (Note 11)	SB	104.9	-	-	kHz	
Passband Ripple	PR	-	-	±0.02	dB	
Stopband Attenuation	SA	54	-	-	dB	
Group Delay Distortion	ΔGD	-	0	-	μs	
Group Delay (Note 12)	GD	-	21	-	1/fs	
DAC Digital Filter + Analog Filter:						
Frequency Response (Note 13)	40kHz	FR	-	-0.3	-	dB

Note 11. The passband and stopband frequencies scales with f_s (sampling frequency). For example, ADC: Passband ($\pm 0.1\text{dB}$) = $0.39375 \times f_s$ (@ $f_s=48\text{kHz}$), DAC: Passband ($\pm 0.06\text{dB}$) = $0.45412 \times f_s$.

Note 12. The calculated delay time resulting from digital filtering. For the ADC, this time is from the input of an analog signal to the setting of 24bit data for both channels to the ADC output register. For the DAC, this time is from setting the 24 bit data both channels at the input register to the output of an analog signal.

Note 13. The reference frequency is 1kHz.

DC CHARACTERISTICS

($T_a=-40 \sim +85^\circ\text{C}$; $V_A, V_D=2.4 \sim 3.6\text{V}$)

Parameter	Symbol	Min.	Typ.	Max.	Unit
High-Level Input Voltage	V_{IH}	70%VD	-	-	V
Low-Level Input Voltage	V_{IL}	-	-	30%VD	V
High-Level Output Voltage ($I_{out}=-100\mu\text{A}$)	V_{OH}	VD-0.5	-	-	V
Low-Level Output Voltage ($I_{out}=100\mu\text{A}$)	V_{OL}	-	-	0.5	V
Input Leakage Current	I_{in}	-	-	± 10	μA

SWITCHING CHARACTERISTICS

(Ta=-40 ~ +85°C; VA, VD=2.4 ~ 3.6V; CL=20pF)

Parameter	Symbol	Min.	Typ.	Max.	Unit	
Master Clock Timing (MCLK)						
Frequency: 128fs, 256fs, 512fs	fCLK	2.048	-	27.648	MHz	
192fs, 384fs, 768fs	fCLK	3.072	-	36.864	MHz	
Pulse Width Low	tCLKL	0.4/fCLK	-	-	ns	
Pulse Width High	tCLKH	0.4/fCLK	-	-	ns	
LRCK (VA, VD = 2.4V~3.6V)						
Frequency	Normal Speed: 256fs, 512fs	fs	8	-	54	kHz
		fs	8	-	48	kHz
	Double Speed: 256fs, 384fs	fs	54	-	108	kHz
		fs	48	-	96	kHz
Duty Cycle	Slave mode		45	-	55	%
	Master mode		-	50	-	%
LRCK (VA, VD = 2.7V~3.6V)						
Frequency	Quad Speed: 128fs	fs	108	-	216	kHz
	192fs	fs	96	-	192	kHz
Duty Cycle	Slave mode		45	-	55	%
	Master mode		-	50	-	%
Audio Interface Timing						
Slave mode (VA, VD = 2.4V ~ 2.7V)						
BCLK Period: Normal Speed	tBCK	1/128fs	-	-	ns	
	tBCK	1/64fs	-	-	ns	
BCLK Pulse Width Low	tBCKL	60	-	-	ns	
	tBCKH	60	-	-	ns	
LRCK Edge to BCLK “↑” (Note 14)	tLRB	20	-	-	ns	
BCLK “↑” to LRCK Edge (Note 14)	tBLR	20	-	-	ns	
LRCK to SDTO (MSB) (Except I ² S mode)	tDLR	-	-	40	ns	
BCLK “↓” to SDTO	tBSD	-	-	40	ns	
SDTI Hold Time	tSDH	20	-	-	ns	
SDTI Setup Time	tSDS	20	-	-	ns	
Slave mode (VA, VD = 2.7V ~ 3.6V)						
BCLK Period: Normal Speed	tBCK	1/128fs	-	-	ns	
	tBCK	1/64fs	-	-	ns	
BCLK Pulse Width Low	tBCKL	33	-	-	ns	
	tBCKH	33	-	-	ns	
LRCK Edge to BCLK “↑” (Note 14)	tLRB	20	-	-	ns	
BCLK “↑” to LRCK Edge (Note 14)	tBLR	20	-	-	ns	
LRCK to SDTO (MSB) (Except I ² S mode)	tDLR	-	-	20	ns	
BCLK “↓” to SDTO	tBSD	-	-	20	ns	
SDTI Hold Time	tSDH	13	-	-	ns	
SDTI Setup Time	tSDS	13	-	-	ns	

Note 14. BCLK rising edge must not occur at the same time as LRCK edge.

SWITCHING CHARACTERISTICS (Continued)

(Ta=-40 ~ +85°C; VA, VD=2.4 ~ 3.6V; CL=20pF)

Parameter	Symbol	Min.	Typ.	Max.	Unit	
Master mode (VA, VD = 2.4V ~ 2.7V)						
BCLK Frequency	fBCK	-	64fs	-	Hz	
BCLK Duty	dBCK	-	50	-	%	
BCLK “↓” to LRCK	tMBLR	-20	-	40	ns	
BCLK “↓” to SDTO	tBSD	-20	-	40	ns	
SDTI Hold Time	tSDH	20	-	-	ns	
SDTI Setup Time	tSDS	20	-	-	ns	
Master mode (VA, VD = 2.7V ~ 3.6V)						
BCLK Frequency	fBCK	-	64fs	-	Hz	
BCLK Duty	dBCK	-	50	-	%	
BCLK “↓” to LRCK	tMBLR	-20	-	20	ns	
BCLK “↓” to SDTO	tBSD	-20	-	20	ns	
SDTI Hold Time	tSDH	13	-	-	ns	
SDTI Setup Time	tSDS	13	-	-	ns	
Reset Timing						
PDN Pulse Width (Note 15)	tPW	150	-	-	ns	
PDN “↑” to SDTO valid (Note 16)						
Slave Mode	Noraml Speed	tPWV	-	4134	-	1/fs
	Double Speed	tPWV	-	8262	-	1/fs
	Quad Speed	tPWV	-	16518	-	1/fs
Master Mode	Normal Speed	tPWV	-	4131	-	1/fs
	Double Speed	tPWV	-	8259	-	1/fs
	Quad Speed	tPWV	-	16515	-	1/fs

Note 15. The AK4556 can be reset by bringing the PDN pin = “L”.

Note 16. This cycle is the number of LRCK rising edges from the PDN pin = “H”.

■ Timing Diagram

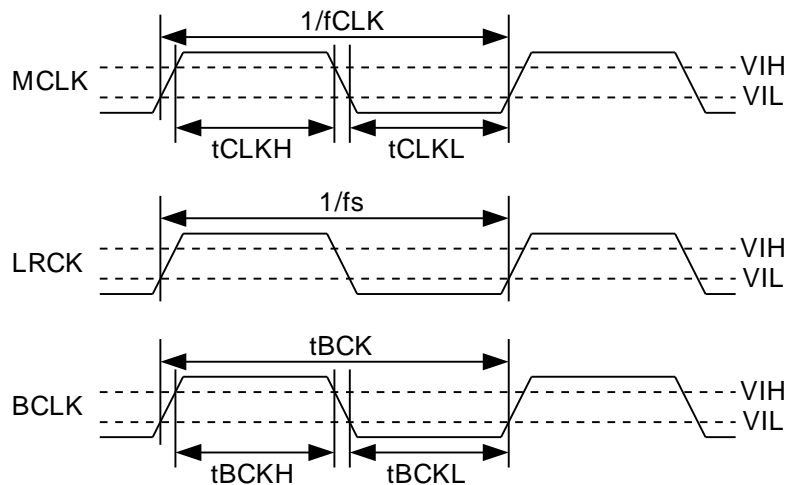

Figure 2. Clock Timing

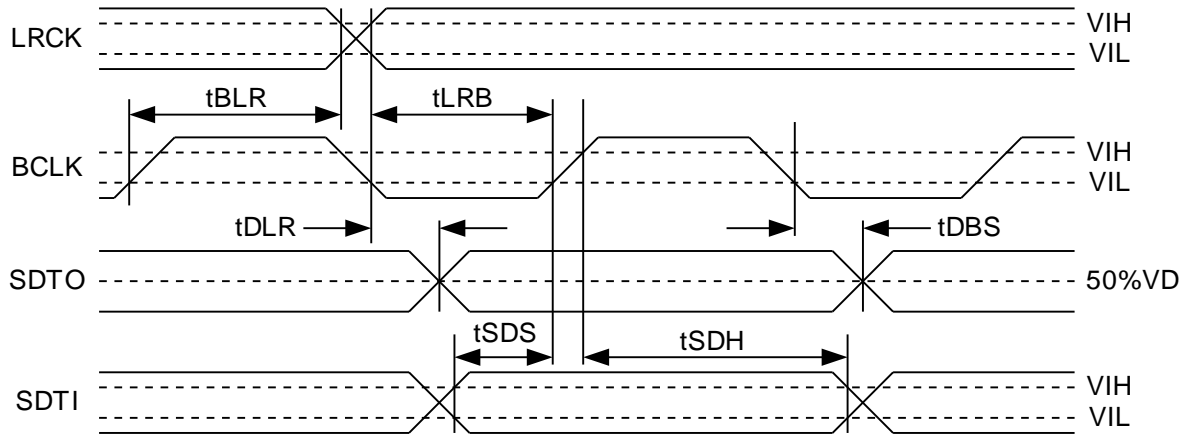

Figure 3. Audio Data Input/Output Timing (Slave)

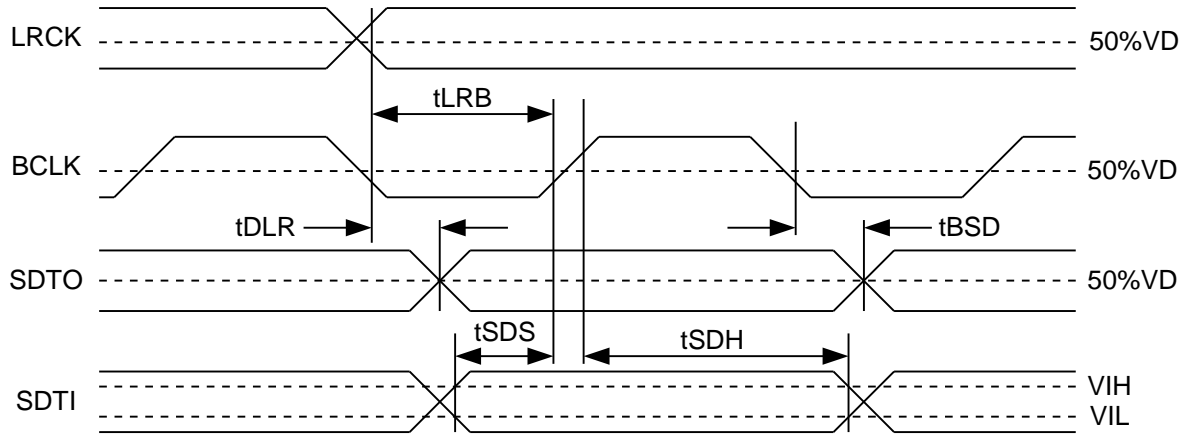

Figure 4. Audio Data Input/Output Timing (Master)

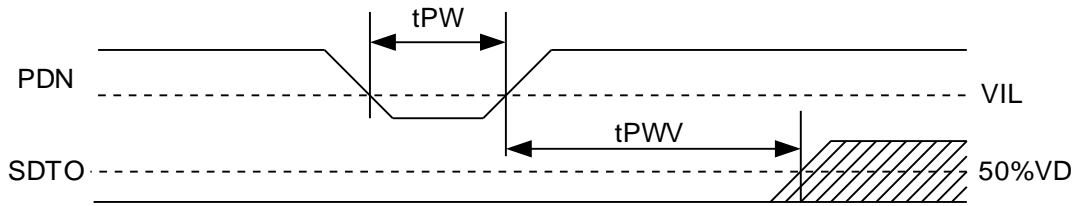

Figure 5. Reset Timing

OPERATION OVERVIEW

■ System Clock

MCLK, BCLK and LRCK (fs) clocks are required in slave mode. The LRCK clock input must be synchronized with MCLK, however the phase is not critical. Table 1 shows the relationship of typical sampling frequency and the system clock frequency. MCLK frequency, BCLK frequency, HPF (ON or OFF) and master/slave are selected by CKS3-0 pins as shown in Table 3. When MCLK is 192fs, 384fs or 768fs, the sampling frequency does not support variable pitch (Table 2).

All external clocks (MCLK, BCLK and LRCK) must be present unless the PDN pin = "L". If these clocks are not provided, the AK4556 may draw excess current due to its use of internal dynamically refreshed logic. If the external clocks are not present, place the AK4556 in power-down mode (PDN pin = "L"). In master mode, the master clock (MCLK) must be provided unless the PDN pin = "L".

fs	MCLK					
	128fs	192fs	256fs	384fs	512fs	768fs
32kHz	N/A	N/A	8.192MHz	12.288MHz	16.384MHz	24.576MHz
44.1kHz	N/A	N/A	11.2896MHz	16.9344MHz	22.5792MHz	33.8688MHz
48kHz	N/A	N/A	12.288MHz	18.432MHz	24.576MHz	36.864MHz
96kHz	N/A	N/A	24.576MHz	36.864MHz	N/A	N/A
192kHz	24.576MHz	36.864MHz	N/A	N/A	N/A	N/A

Table 1. System Clock Example (N/A: Not Available)

Mode	Sampling Frequency	MCLK
Normal Speed	$8\text{kHz} \leq fs \leq 54\text{kHz}$	256fs/512fs
	$8\text{kHz} \leq fs \leq 48\text{kHz}$	384fs/768fs
Double Speed	$54\text{kHz} < fs \leq 108\text{kHz}$	256fs
	$48\text{kHz} < fs \leq 96\text{kHz}$	384fs
Quad Speed	$108\text{kHz} < fs \leq 216\text{kHz}$	128fs
	$96\text{kHz} < fs \leq 192\text{kHz}$	192fs

Table 2. Sampling Frequency Range

Mode	CKS3 pin	CKS2 pin	CKS1 pin	CKS0 pin	HPF	M/S	MCLK	Audio Interface Format (See Table 4)
0 (*)	L	L	L	L	ON	Slave	128/192fs (Quad Speed) 256/384fs (Double Speed) 512/768fs (Normal Speed)	LJ/RJ
1	L	L	L	H	ON	Slave	256/384/512/768fs (Normal Speed)	LJ/RJ
2	L	L	H	L	OFF	Slave	128/192fs (Quad Speed) 256/384fs (Double Speed) 512/768fs (Normal Speed)	LJ/RJ
3	L	L	H	H	OFF	Slave	256/384/512/768fs (Normal Speed)	LJ/RJ
4	L	H	L	L	ON	Slave	128/192fs (Quad Speed) 256/384fs (Double Speed) 512/768fs (Normal Speed)	I ² S
5	L	H	L	H	ON	Slave	256/384/512/768fs (Normal Speed)	I ² S
6	L	H	H	L	OFF	Slave	128/192fs (Quad Speed) 256/384fs (Double Speed) 512/768fs (Normal Speed)	I ² S
7	L	H	H	H	OFF	Slave	256/384/512/768fs (Normal Speed)	I ² S
8	H	L	L	L	ON	Slave	128/192fs (Quad Speed) 256/384fs (Double Speed) 512/768fs (Normal Speed)	LJ
9	H	L	L	H	ON	Slave	256/384/512/768fs (Normal Speed)	LJ
10	H	L	H	L	OFF	Slave	128/192fs (Quad Speed) 256/384fs (Double Speed) 512/768fs (Normal Speed)	LJ
11	H	L	H	H	OFF	Slave	256/384/512/768fs (Normal Speed)	LJ
12	H	H	L	L	ON	Master	256fs (Double Speed)	I ² S
13	H	H	L	H	ON	Master	512fs (Normal Speed)	I ² S
14	H	H	H	L	ON	Master	128fs (Quad Speed)	I ² S
15	H	H	H	H	ON	Master	256fs (Normal Speed)	I ² S

* AK4552 Compatible mode

Table 3. Mode Setting

■ Audio Serial Interface Format

Three modes are supported and selected by the CKS3-0 pins as shown in Table 3 and Table 4. In all modes the serial data format is MSB first, 2's complement. The SDTO is clocked out on the falling edge of BCLK and the SDTI is latched on the rising edge. The audio interface supports both master and slave modes. In slave mode, BCLK and LRCK are input. In master mode, BCLK and LRCK are output with the BCLK frequency fixed to 64fs and the LRCK frequency fixed to 1fs. Also audio interface format is fixed to I²S mode.

Mode	SDTO	SDTI	LRCK	BCLK (Slave)	BCLK (Master)
LJ	24bit, MSB justified	24bit, MSB justified	H/L	≥ 48fs	-
I ² S	24bit, I ² S Compatible	24bit, I ² S Compatible	L/H	≥ 48fs or 32fs	64fs
LJ/RJ	24bit, MSB justified	24bit, LSB justified	H/L	≥ 48fs	-

Table 4. Audio Interface Format

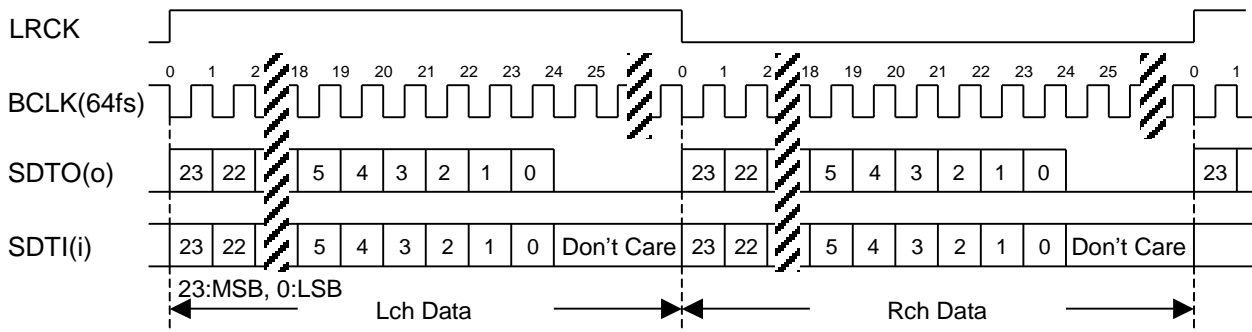

Figure 6. Mode LJ Timing

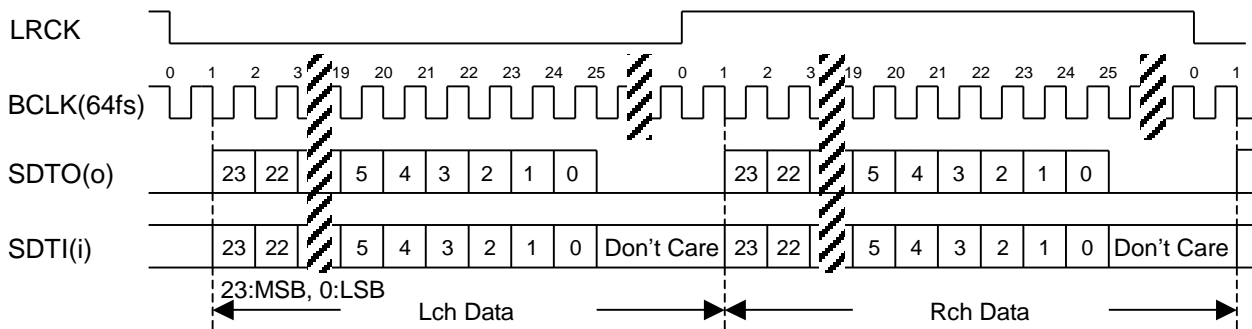

Figure 7. Mode I²S Timing

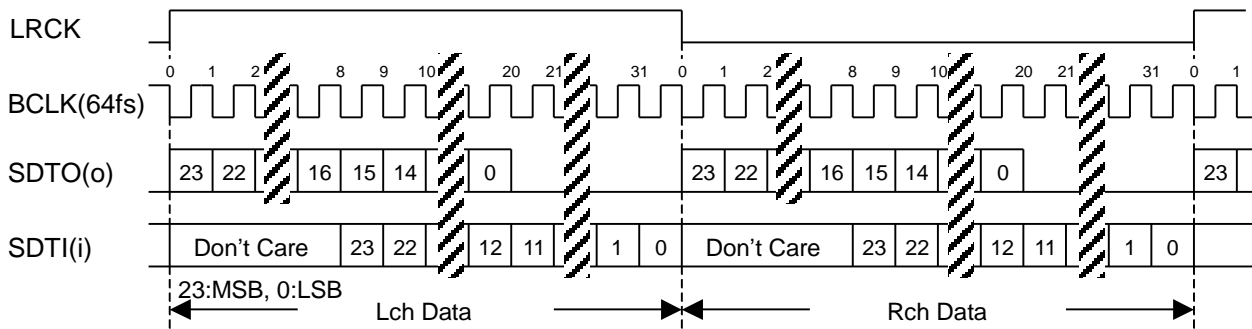

Figure 8. Mode LJ/RJ Timing

■ De-emphasis Filter

The DAC includes a digital de-emphasis filter ($t_c=50/15\mu s$) via an integrated by IIR filter. This filter corresponds to three frequencies (32kHz, 44.1kHz, 48kHz). This setting is done by DEM0 and DEM1 pins. This filter is always OFF in double and quad speed modes.

DEM1	DEM0	Mode
0	0	44.1kHz
0	1	OFF
1	0	48kHz
1	1	32kHz

Table 5. De-emphasis filter control

■ Digital High Pass Filter

The ADC has a Digital High Pass Filter (HPF) for DC-offset cancellation. The cut-off frequency of the HPF is 1Hz at $f_s=48\text{kHz}$ and the frequency response at 20Hz is -0.12dB. It also scales with the sampling frequency (f_s). The HPF is controlled by CKS3-0 pins (Table 3). If the HPF setting (ON/OFF) is changed at operating, click noise occurs by changing DC offset.

■ Power-down & Reset

The ADC and DAC are placed in power-down mode by bringing the PDN pin = "L", and each digital filter is also reset at the same time. These resets should always be done after power-up. For the ADC, an analog initialization cycle starts after exiting the power-down mode. The output data, (SDTO) becomes available after 4131 cycles (@ Normal Speed) of LRCK in master mode or 4134 cycles (@ Normal Speed) of LRCK in slave mode. During initialization, the ADC digital data outputs of both channels are forced to a 2's complement "0". The ADC output data settles and correlates to the input signal after the end of initialization (settling time is approximately equal to the group delay time.) The initialization cycle does not affect the DAC operation.

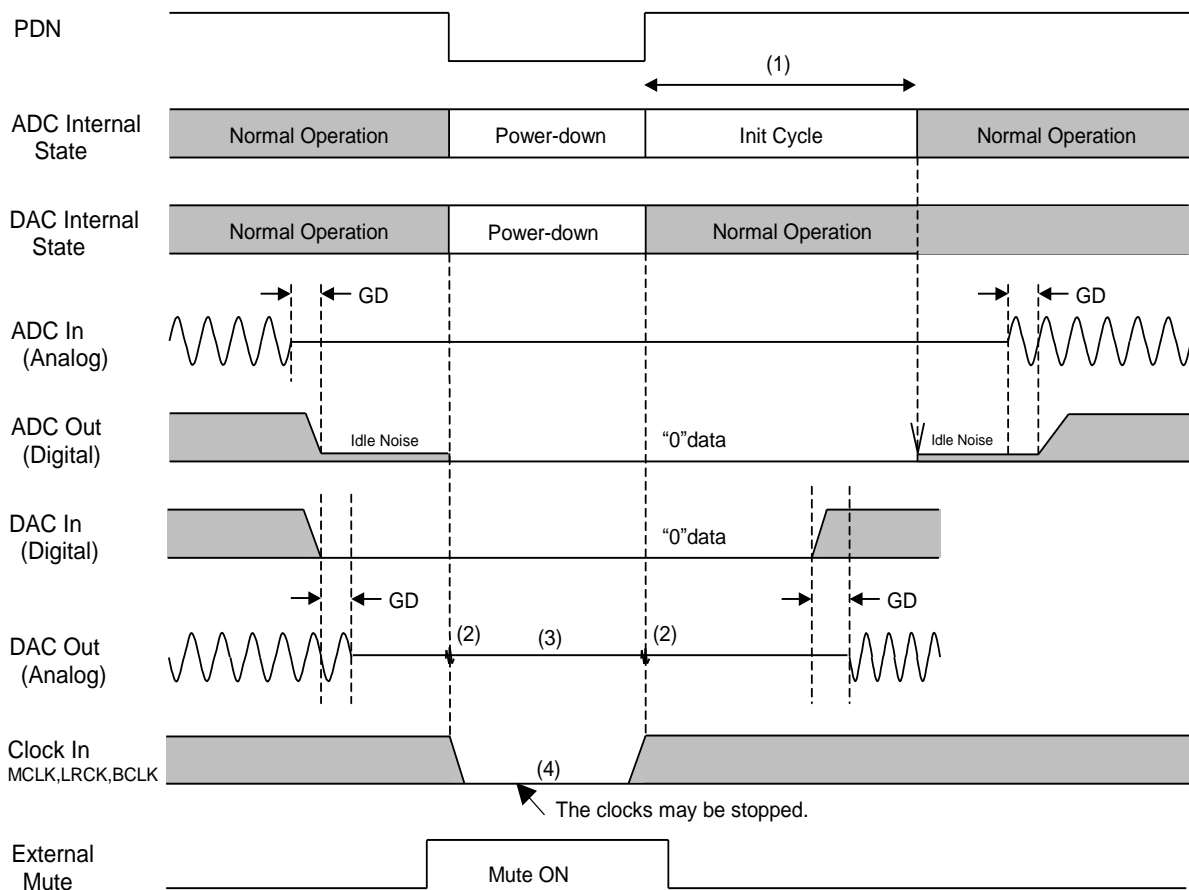

Notes:

- (1) Slave mode (typ): $4134/f_s$ @ Normal Speed, $8262/f_s$ @ Double Speed, $16518/f_s$ @ Quad Speed
Master mode (typ): $4131/f_s$ @ Normal Speed, $8259/f_s$ @ Double Speed, $16515/f_s$ @ Quad Speed
- (2) Click noise occurs at the "↑↓" of PDN signal. Mute the analog output externally if the click noise influences system performance.
- (3) LOUT/ROUT pins become Hi-Z at power-down.
- (4) In master mode, LRCK and BICK output "L" at power-down.

Figure 9. Power-up/down Sequence

■ System Reset

The AK4556 should be reset once by bringing the PDN pin “L” after power-up. In slave mode, reset and power down states are released by MCLK and the internal timing starts clocking on the rising edge of LRCK in Mode LJ and Mode LJ/RJ. In Mode I²S, it starts clocking on the falling edge of BCLK after the first rising edge of BCLK after the falling edge of LRCK. The AK4556 is in power down state until LRCK is input. In master mode, reset and power down states are released by MCLK. The internal timing also starts by MCLK.

SYSTEM DESIGN

Figure 10 shows the system connection diagram. An evaluation board [AKD4556] is available which demonstrates application circuit, optimum layout, power supply arrangements and measurement results.

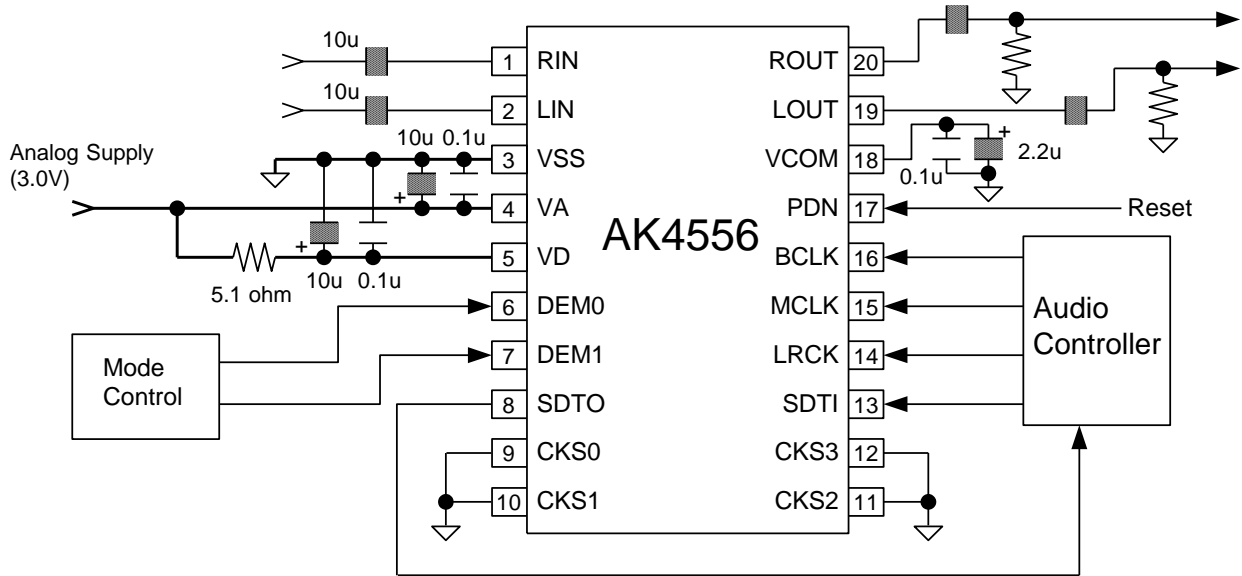

Figure 10. System Connection Diagram Example (Mode 0: AK4552 Compatible Mode)

Notes:

- VSS of the AK4556 should be distributed separately from the ground external digital devices.
- Do not allow digital input pins to float.
- When LOUT/ROUT drives some capacitive load, a 220Ω resistor should be added in series between LOUT/ROUT and capacitive load. In this case, LOUT/ROUT pins can drive capacitor of 400pF.

1. Grounding and Power Supply Decoupling

The AK4556 requires careful attention to power supply and grounding arrangements. VA pin is usually supplied from analog supply in system and VD pin is supplied from VA pin via 5.1Ω. Alternatively if VA and VD pins are supplied separately, the power up sequence is not critical. VSS pin of the AK4556 should be connected to analog ground plane. System analog ground and digital ground should be connected together near to where the supplies are brought onto the printed circuit board. Decoupling capacitors should be as near to the AK4556 as possible, with the small value ceramic capacitor being the nearest.

2. Voltage Reference

The input to VA voltage sets the analog input/output range. A 0.1μF ceramic capacitor and a 10μF electrolytic capacitor are connected to VA and VSS pins, normally. VCOM is a signal ground of this chip. A 2.2μF electrolytic capacitor in parallel with a 0.1μF ceramic capacitor attached to these pins eliminates the effects of high frequency noise. No load current may be drawn from VCOM pin. All signals, especially clock, should be kept away from the VA, VD and VCOM pins in order to avoid unwanted coupling into the AK4556.

3. Analog Inputs

The ADC inputs are single-ended and internally biased to the common voltage (50% VA) with 8kΩ (typ, @fs=48kHz, 96kHz, 192kHz) resistance. The input signal range scales with the supply voltage and nominally 0.7xVA Vpp (typ). The ADC output data format is 2's complement. The internal HPF removes the DC offset.

The AK4556 samples the analog inputs at 128fs (@ fs=48kHz), 64fs (@fs=96kHz) or 32fs(@192kHz). The digital filter rejects noise above the stop band except for multiples of the sampling frequency of analog inputs. The AK4556 includes an anti-aliasing filter (RC filter) to attenuate a noise around the sampling frequency of analog inputs.

4. Analog Outputs

The analog outputs are also single-ended and centered around the VCOM voltage. The input signal range scales with the supply voltage and nominally 0.7 x VA Vpp (typ). The DAC input data format is 2's complement. The output voltage is a positive full scale for 7FFFFFFH(@24bit) and a negative full scale for 800000H(@24bit). The ideal output is VCOM voltage for 000000H(@24bit). If the noise generated by the delta-sigma modulator beyond the audio band would be the problem, the attenuation by external filter is required.

DC offsets on analog outputs are eliminated by AC coupling since DAC outputs have DC offsets of a few mV.

PACKAGE

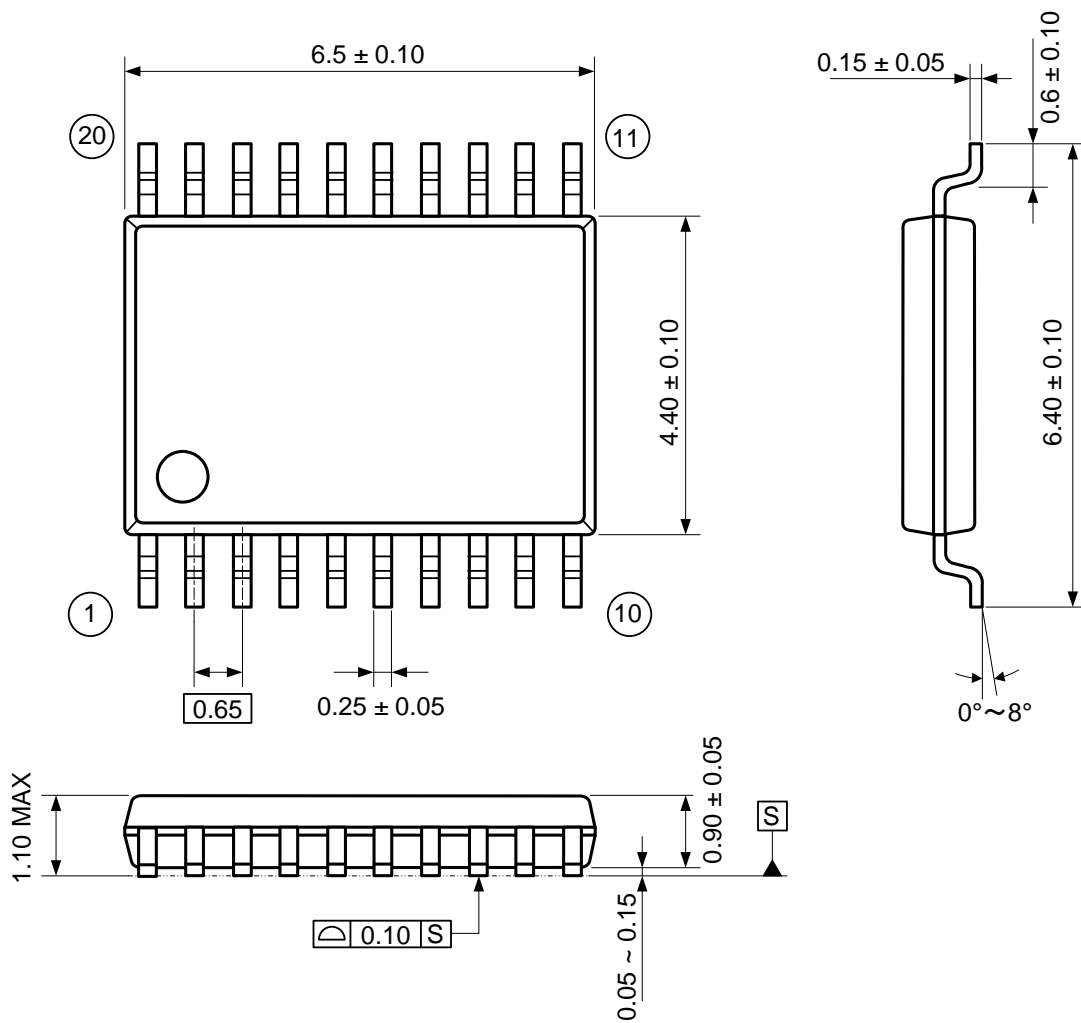

■ Package & Lead frame material

Package molding compound:	Epoxy
Lead frame material:	Cu
Lead frame surface treatment:	Solder (Pb free) plate

MARKING

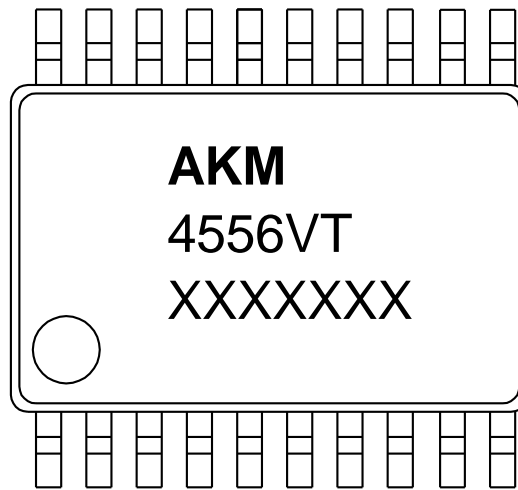

- 1) Pin #1 indication
- 2) Date Code: XXXXXXXX (7 digits)
- 3) Marketing Code: 4556VT

REVISION HISTORY

Date (YY/MM/DD)	Revision	Reason	Page	Contents
06/11/06	00	First Edition		
15/10/30	01	Specification Change	21, 22	PACAGE, MARKING Package dimension and Marking were changed.
15/11/27	02	Error Correction	22	MARKING "X" was added to the marking description.

IMPORTANT NOTICE

0. Asahi Kasei Microdevices Corporation (“AKM”) reserves the right to make changes to the information contained in this document without notice. When you consider any use or application of AKM product stipulated in this document (“Product”), please make inquiries the sales office of AKM or authorized distributors as to current status of the Products.
1. All information included in this document are provided only to illustrate the operation and application examples of AKM Products. AKM neither makes warranties or representations with respect to the accuracy or completeness of the information contained in this document nor grants any license to any intellectual property rights or any other rights of AKM or any third party with respect to the information in this document. You are fully responsible for use of such information contained in this document in your product design or applications. **AKM ASSUMES NO LIABILITY FOR ANY LOSSES INCURRED BY YOU OR THIRD PARTIES ARISING FROM THE USE OF SUCH INFORMATION IN YOUR PRODUCT DESIGN OR APPLICATIONS.**
2. The Product is neither intended nor warranted for use in equipment or systems that require extraordinarily high levels of quality and/or reliability and/or a malfunction or failure of which may cause loss of human life, bodily injury, serious property damage or serious public impact, including but not limited to, equipment used in nuclear facilities, equipment used in the aerospace industry, medical equipment, equipment used for automobiles, trains, ships and other transportation, traffic signaling equipment, equipment used to control combustions or explosions, safety devices, elevators and escalators, devices related to electric power, and equipment used in finance-related fields. Do not use Product for the above use unless specifically agreed by AKM in writing.
3. Though AKM works continually to improve the Product’s quality and reliability, you are responsible for complying with safety standards and for providing adequate designs and safeguards for your hardware, software and systems which minimize risk and avoid situations in which a malfunction or failure of the Product could cause loss of human life, bodily injury or damage to property, including data loss or corruption.
4. Do not use or otherwise make available the Product or related technology or any information contained in this document for any military purposes, including without limitation, for the design, development, use, stockpiling or manufacturing of nuclear, chemical, or biological weapons or missile technology products (mass destruction weapons). When exporting the Products or related technology or any information contained in this document, you should comply with the applicable export control laws and regulations and follow the procedures required by such laws and regulations. The Products and related technology may not be used for or incorporated into any products or systems whose manufacture, use, or sale is prohibited under any applicable domestic or foreign laws or regulations.
5. Please contact AKM sales representative for details as to environmental matters such as the RoHS compatibility of the Product. Please use the Product in compliance with all applicable laws and regulations that regulate the inclusion or use of controlled substances, including without limitation, the EU RoHS Directive. AKM assumes no liability for damages or losses occurring as a result of noncompliance with applicable laws and regulations.
6. Resale of the Product with provisions different from the statement and/or technical features set forth in this document shall immediately void any warranty granted by AKM for the Product and shall not create or extend in any manner whatsoever, any liability of AKM.
7. This document may not be reproduced or duplicated, in any form, in whole or in part, without prior written consent of AKM.

X-ON Electronics

Largest Supplier of Electrical and Electronic Components

Click to view similar products for [Interface - CODECs](#) category:

Click to view products by [Asahi Kasei](#) manufacturer:

Other Similar products are found below :

[CS4205-KQZ](#) [ZL38015QCG1](#) [MAX98090AEWJ+T](#) [WM9713CLGEFLV](#) [LE58QL061BVC](#) [MAX9867ETJ+G3U](#) [ADAU1777BCBZRL](#)
[WM8944BECS/R](#) [TDA7293V-E](#) [WM8998ECS/R](#) [WM8778SEDS/V](#) [CS42L73-CRZR](#) [WM8750CJLGEFL](#) [STA529Q](#) [SSM2603CPZ-REEL](#)
[TLV320AIC14IDBT](#) [TLV320AIC23BIPWRQ1](#) [TLV320AIC23IPW](#) [TVP5151PBSR](#) [MAX98090BETL+](#) [MAX98089ETN+](#)
[MAX98089ETNT](#) [TLV320AIC34IZASR](#) [TLV320AIC3262IYZFR](#) [SA612AD/01.112](#) [ADAU1372BCPZ-RL](#) [MAX98090AETL+](#)
[MAX9880AETM](#) [WM8962ECSN/R](#) [TLV320DAC3203IRGER](#) [WM8904CGEFL/RV](#) [6PAIC3106IRGZRQ1](#) [CS42436-DMZ](#)
[TSCS25A3X1NDGXZAX](#) [BU94502CMUV-E2](#) [TDA8932BT/N2.112](#) [TDA8954J/N1.112](#) [ICS512MLF](#) [92HD73C1T5PRGIC1X](#)
[92HD73C1X5PRGXC1X](#) [SSM2167-1RMZ](#) [AD1836AASZ](#) [AD1836ACSZ](#) [AD1928YSTZ](#) [AD1937WBSTZ](#) [AD1938WBSTZ](#)
[AD1939WBSTZ](#) [AD73311ARSZ](#) [AD73311ARZ](#) [AD73311LARUZ](#)