

■ GENERAL DESCRIPTION

ASOPD4580 is the dual operational amplifier, specially designed for improving the tone control, which is most suitable for the audio application.

Featuring noiseless, higher gain bandwidth, high output current and low distortion ratio, and it is most suitable not only for acoustic electronic parts of audio pre-amp and active filter, but also for the industrial measurement tools. It is also suitable for the head phone amp at higher output current, and further more, it can be applied for the handy type set operational amplifier of general purpose in application of low voltage single supply type which is properly biased of the low voltage source.

■ FEATURES

- Operating Voltage $\pm 2V \sim \pm 18V$
- Low Input Noise Voltage $0.8\mu V_{rms}$ typ. (RIAA)
- Wide GBW $15MHz$ typ.
- Low Distortion 0.0005% typ.
- Slew Rate $5V/\mu s$ typ.
- Bipolar Technology
- Package Outline SOP8 ,DIP8

■ Pin Configuration

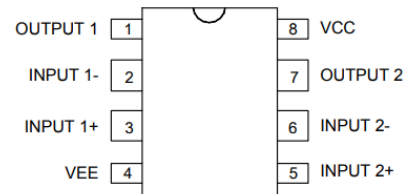

Top View

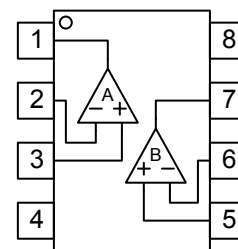

Pin No.	Function	Pin No.	Function	Pin No.	Function	Pin No.	Function
1	OUTPUT 1	2	INPUT 1-	3	INPUT 1+	4	VEE
5	INPUT 2+	6	INPUT 2-	7	OUTPUT 2	8	VCC

■ EQUIVALENT CIRCUIT (1/2 Shown)

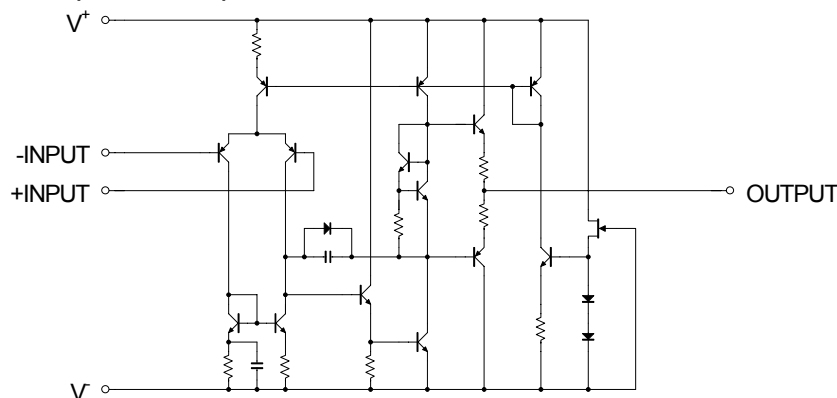



■ ABSOLUTE MAXIMUM RATINGS (Ta=25°C, unless otherwise noted.)

PARAMETER		RATING	UNIT
Supply Voltage	V^+V^-	±18	V
Input Voltage	V_{IN}	±15 (note1)	V
Differential Input Voltage Range	V_{ID}	±30	V
Power Dissipation	P_D	550 (note2) 820 (note3)	mW
Operating Temperature Range	opr	-40~+85	°C
Storage Temperature Range	Tstg	-40~+125	°C

(note1) For supply voltage less than ±15V, the absolute maximum input voltage is equal to supply voltage.

(note2) EIA/JEDEC STANDARD Test board (76.2 x 114.3 x 1.6mm, 2layers, FR-4) mounting

(note3) EIA/JEDEC STANDARD Test board (76.2 x 114.3 x 1.6mm, 4layers, FR-4) mounting

■ RECOMMENDED OPERATING CONDITIONS (Ta=25°C)

PARAMETER		CONDITION	MIN.	TYP.	MAX.	UNIT
Supply Voltage	V^+V^-		±2		±18	V

■ ELECTRICAL CHARACTERISTICS (V^+V^- =±15V, Ta=25°C, unless otherwise noted.)

PARAMETER		TEST CONDITION	MIN.	TYP.	MAX.	UNIT
Input Offset Voltage	V_{IO}	$R_S \leq 10k\Omega$	-	0.3	3	mV
Input Offset Current	I_{IO}		-	5	200	nA
Input Bias Current	I_B		-	100	500	nA
Voltage Gain	A_V	$R_L \geq 2k\Omega, V_O = \pm 10V$	90	110	-	dB
Maximum Output Voltage	V_{OM}	$R_L \geq 2k\Omega$	±12	±13.5	-	V
Common Mode Input Voltage Range	V_{ICM}		±12	±13.5	-	V
Common Mode Rejection Ratio	CMR	$R_S \leq 10k\Omega$	90	110	-	dB
Supply Voltage Rejection Ratio	SVR	$R_S \leq 10k\Omega$	90	110	-	dB
Supply Current	I_{CC}		-	6	9	mA
Slew Rate	SR	$R_L \geq 2k\Omega$	-	5	-	V/ μ s
Gain Bandwidth Product	GB	$f = 10kHz$	-	15	-	MHz
Total Harmonic Distortion	THD	$A_V = 20dB, V_O = 5V, R_L = 2k\Omega, f = 1kHz$		0.0005	-	%
Equivalent Input Noise Voltage	V_{NI}	RIAA, $R_S = 2.2k\Omega, 30kHz$ LPF	-	0.8	-	μ Vrms



TYPICAL CHARACTERISTICS

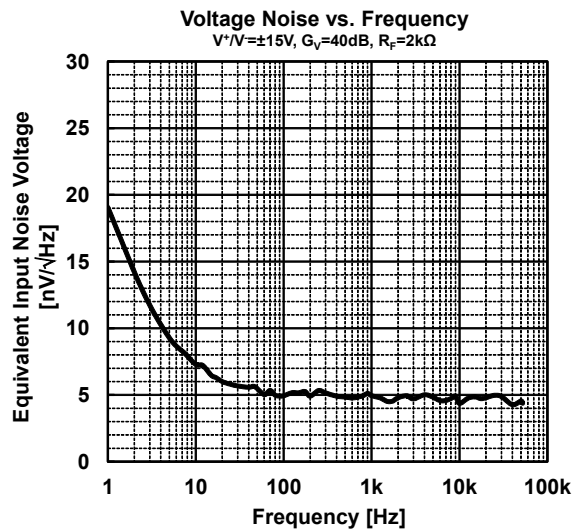
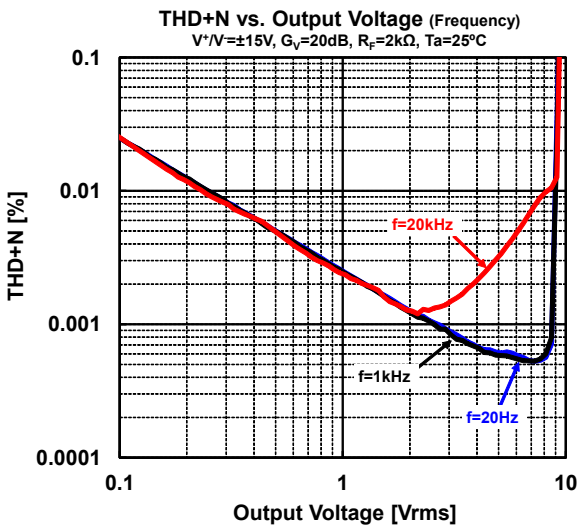
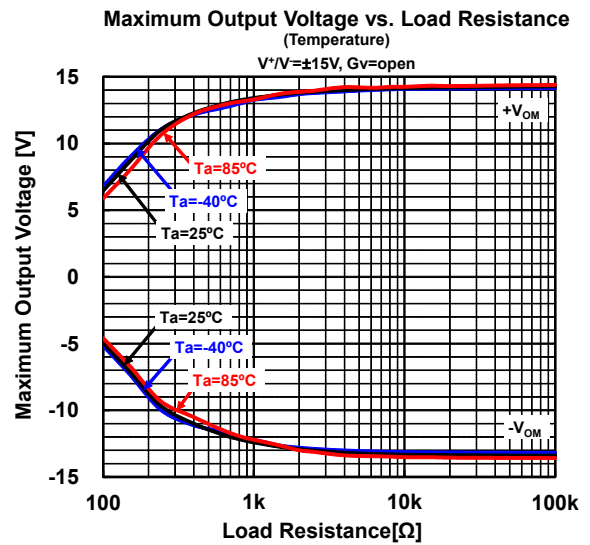
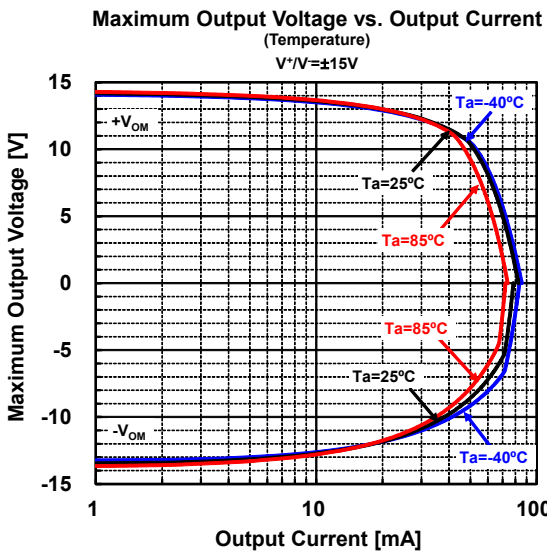
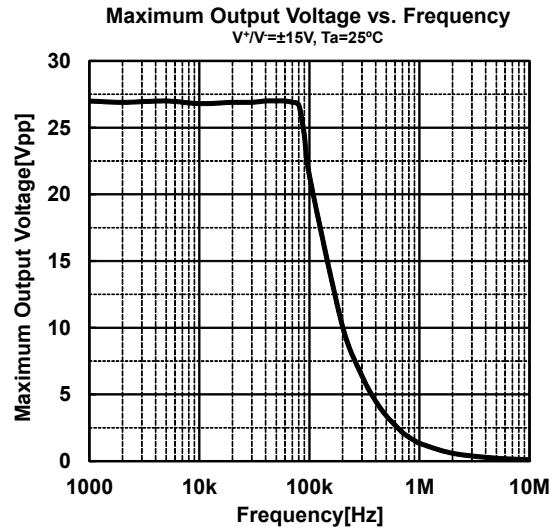
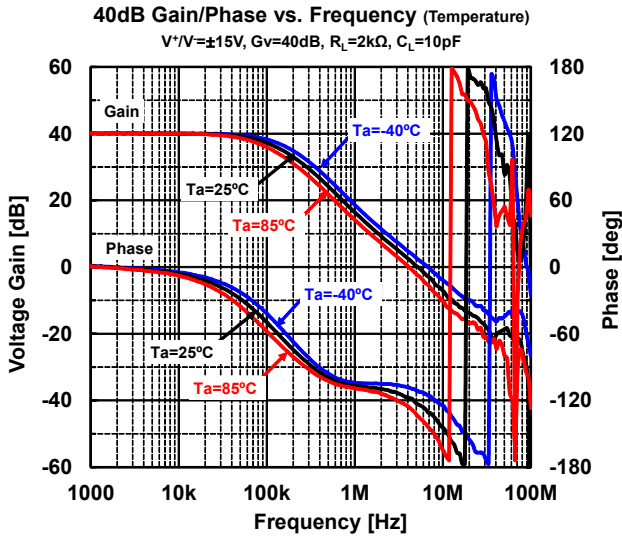



TYPICAL CHARACTERISTICS

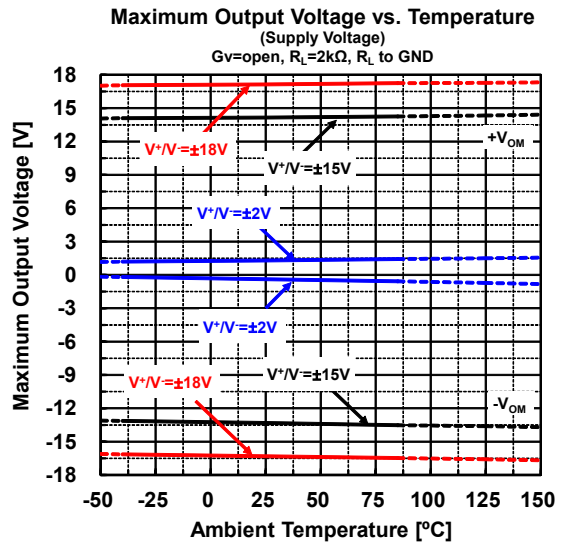
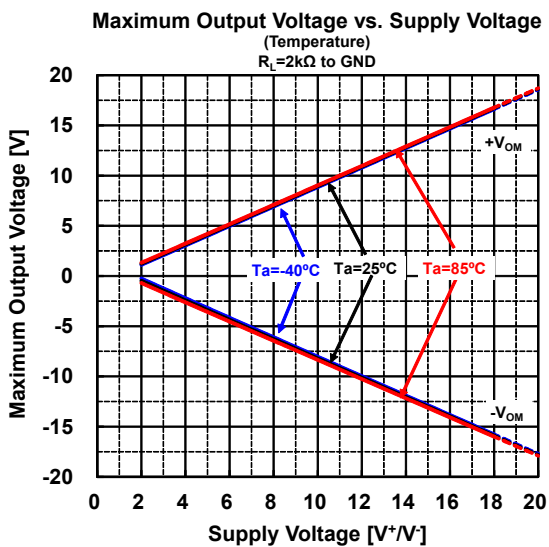
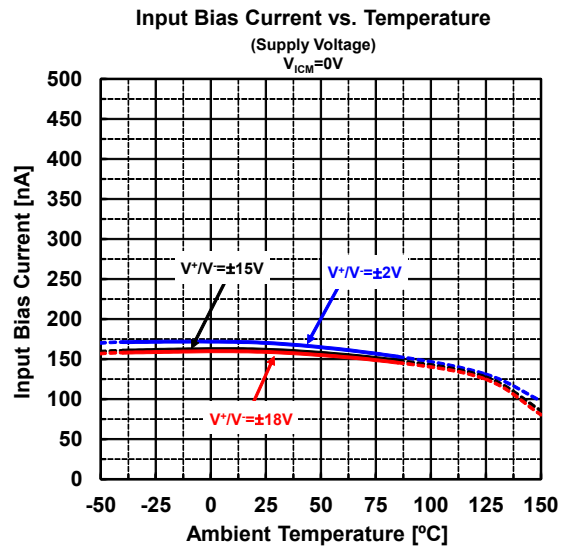
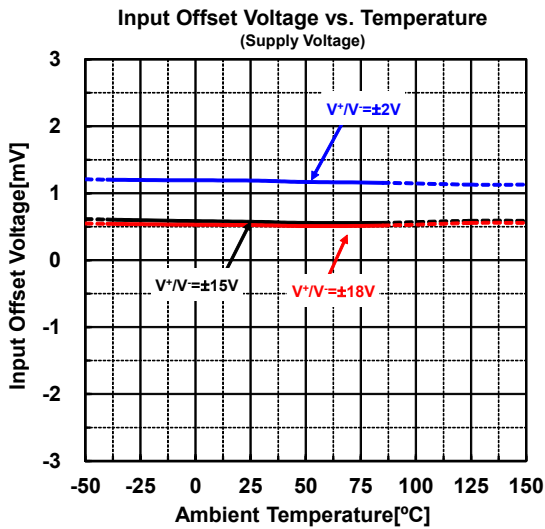
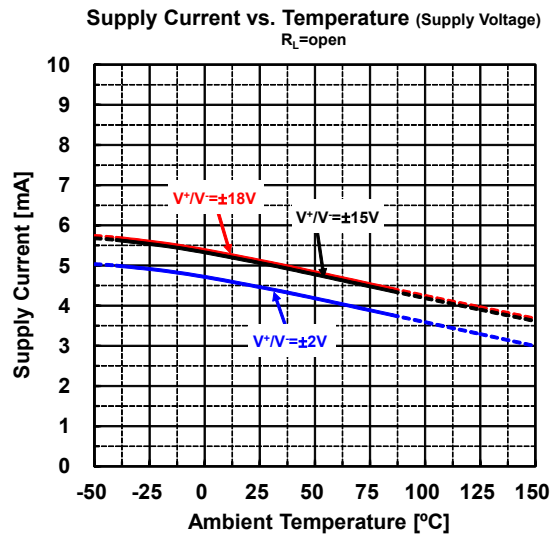
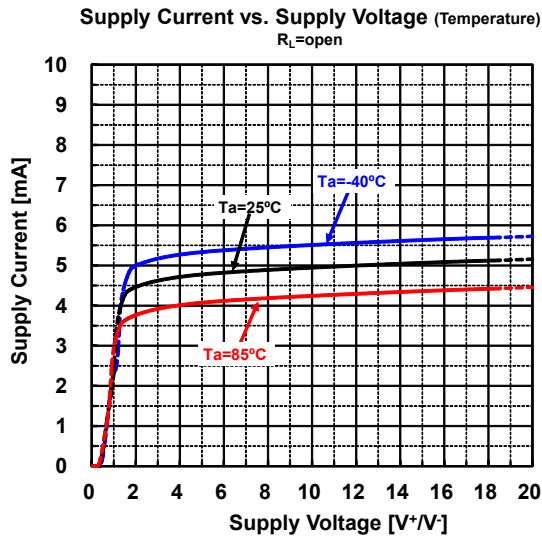



■ Noise Voltage (RIAA) measurement circuit

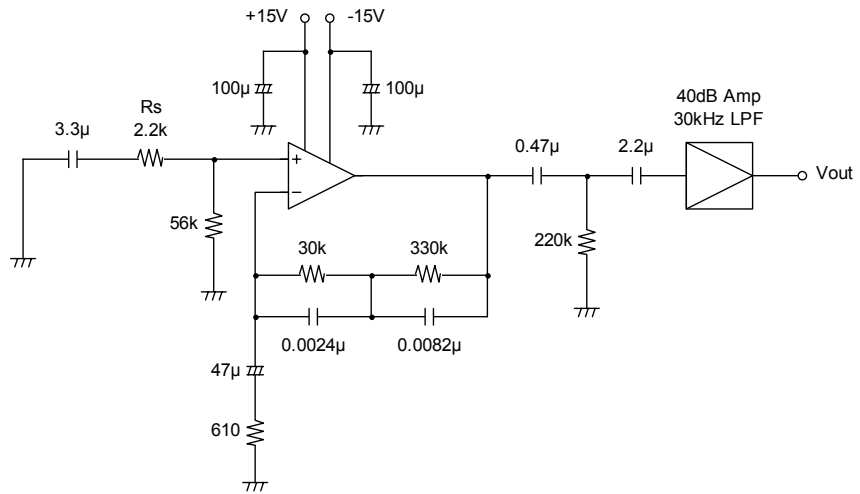



Ordering and Marking Information

Device	Marking	Package	Packaging	Quantity
ASOPD4580S-R	D4580	SOP8L	Tape&Reel	2500/Reel
ASOPD4580N-T	D4580	DIP8L	Tube	50/Tube

PACKAGE	MARKING
SOP-8L DIP-8L	<p>The diagram shows a rectangular marking area. On the left is the 'AS' logo. In the center is 'D4580'. To the right of 'D4580' are two rows of boxes: the top row has three boxes labeled 'Lot Number' and the bottom row has four boxes labeled 'Date Code'.</p>



■ Package Dimension

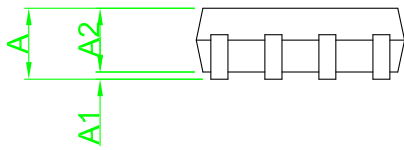
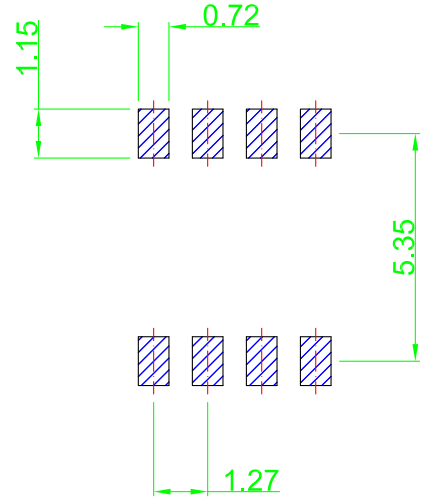
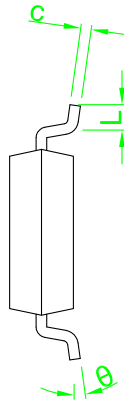
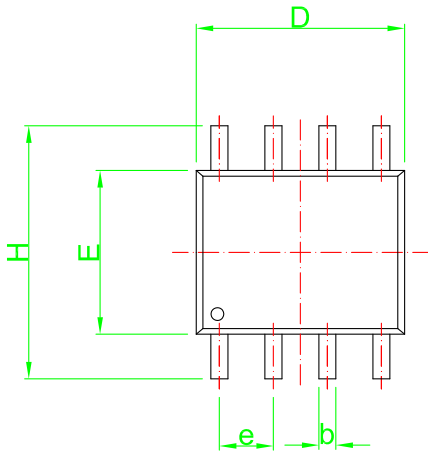

SOP8

Recommended Land Pattern

Symbol	Dimensions in Millimeters		Dimensions in Inches	
	Min	Max	Min	Max
A	---	1.75	---	0.069
A1	0.00	0.26	0.000	0.010
A2	1.30	1.70	0.051	0.067
b	0.30	0.55	0.012	0.022
C	0.15	0.35	0.006	0.014
D	4.80	5.00	0.189	0.197
E	3.80	4.00	0.150	0.157
e	1.27 TYP		0.050 TYP	
H	5.70	6.30	0.224	0.248
L	0.45	0.85	0.018	0.033
θ	0°	8°	0°	8°

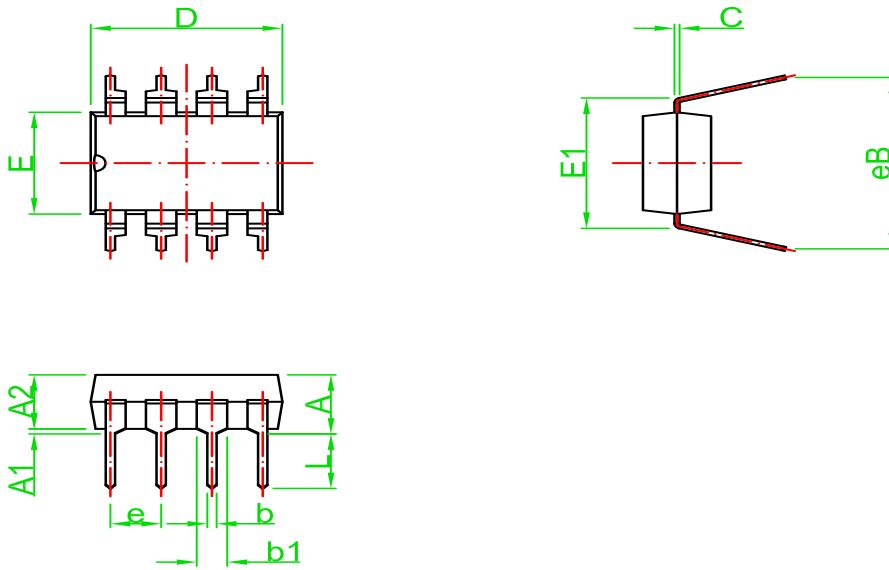

DIP8

Symbol	Dimensions In Millimeters		Dimensions In Inches	
	M	M	M	M
A	3.60	4.80	0.142	0.210
A1	0.38	---	0.015	---
A2	3.05	3.65	0.120	0.210
b	0.36	0.51	0.014	0.020
b1	1.14	1.78	0.045	0.070
C	0.20	0.36	0.008	0.014
D	9.02	10.16	0.355	0.400
E	6.10	7.11	0.240	0.280
E1	7.45	8.26	0.300	0.325
e	2.54 BSC		0.100 BSC	
eB	7.62	10.92	0.300	0.430
L	2.92	3.81	0.115	0.150

**IMPORTANT NOTICE**

Xi'an Ascend Semiconductor incorporated MAKES NO WARRANTY OF ANY KIND, EXPRESS OR IMPLIED, WITH REGARDS TO THIS DOCUMENT, INCLUDING, BUT NOT LIMITED TO, THE IMPLIED WARRANTIES OF MERCHANTABILITY AND FITNESS FOR A PARTICULAR PURPOSE (AND THEIR EQUIVALENTS UNDER THE LAWS OF ANY JURISDICTION).

Xi'an Ascend Semiconductor Incorporated and its subsidiaries reserve the right to make modifications, enhancements, improvements, corrections or other changes without further notice to this document and any product described herein. Xi'an Ascend Semiconductor Incorporated does not assume any liability arising out of the application or use of this document or any product described herein; neither does Xi'an Ascend Semiconductor Incorporated convey any license under its patent or trademark rights, nor the rights of others. Any Customer or user of this document or products described herein in such applications shall assume .

all risks of such use and will agree to hold Ascendsemi Incorporated and all the companies whose products are represented on Xi'an Ascend Semiconductor Incorporated website, harmless against all damages.

Xi'an Ascend Semiconductor Incorporated does not warrant or accept any liability whatsoever in respect of any products purchased through unauthorized sales channel. Should Customers purchase or use Xi'an Ascend Semiconductor Incorporated products for any unintended or unauthorized application, Customers shall indemnify and hold Xi'an Ascend Semiconductor Incorporated and its representatives harmless against all claims, damages, expenses, and attorney fees arising out of, directly or indirectly, any claim of personal injury or death associated with such unintended or unauthorized application.

www.ascendsemi.com

X-ON Electronics

Largest Supplier of Electrical and Electronic Components

Click to view similar products for [Operational Amplifiers - Op Amps](#) category:

Click to view products by [Ascend](#) manufacturer:

Other Similar products are found below :

[SC2902DTBR2G](#) [430227FB](#) [AZV831KTR-G1](#) [UPC451G2-A](#) [UPC824G2-A](#) [LT1678IS8](#) [042225DB](#) [058184EB](#) [UPC822G2-A](#) [UPC258G2-A](#) [NCS5651MNTXG](#) [NCV33202DMR2G](#) [NJM324E](#) [NTE925](#) [5962-9080901MCA*](#) [AP4310AUMTR-AG1](#) [HA1630D02MMEL-E](#) [HA1630S01LPEL-E](#) [SCY33178DR2G](#) [NJU77806F3-TE1](#) [NCV5652MUTWG](#) [NCV20034DR2G](#) [LM2902EDR2G](#) [NTE778S](#) [NTE871](#) [NTE924](#) [NTE937](#) [MCP6V16UT-E/OT](#) [MCP6V17T-E/MS](#) [MCP6V19T-E/ST](#) [SCY6358ADR2G](#) [LTC2065IUD#PBF](#) [NCS20282FCTTAG](#) [UPC4741G2-E1-A](#) [LM4565FVT-GE2](#) [EL5420CRZ-T7A](#) [TSV791IYLT](#) [TSV772IQ2T](#) [TLV2772QPWR](#) [NJM4556AM-TE1](#) [NJM2068M-TE1](#) [AS324MTR-E1](#) [AS358MMTR-G1](#) [MCP6232T-EMNY](#) [MCP662-E/MF](#) [TLC081AIP](#) [TLC082AIP](#) [TLE2074ACDW](#) [TLV07IDR](#) [TLV2170IDGKT](#)