Description

The configurator in-system programming cable (ISP cable) is a PC-only based cable that attaches to the parallel port of a computer. This cable can be used to download and verify configuration data cascading up to 8 devices. This cable allows designers to quickly and economically program Atmel's family of AT17 configuration memories. It also provides support for new devices in the AT17 family prior to third-party programmer support being available. Therefore, it is a truly portable solution that allows engineers to work from their lab bench or office.

Supported Devices

The AT17 series configurators can interface with many SRAM-based FPGA families. This document is limited to example implementations for the following families:

- Atmel – AT94K(FPSLIC), AT40K, AT6K
- Xilinx – XC4000, XC5200, Spartan®, Spartan2, Virtex®, VirtexE
- Altera – EPF6K, EPF8K, EPF10K
- Cypress – Delta39K15, 39K30, 39K50, 39K100, 39K165, 39K200

Software Support

Make sure to use the latest CPS software (<http://www.atmel.com/atmel/products/prod185.htm>). CPS is used to program configurators and supports both the ATDH2200E programming board and this ISP cable. CPS also includes a conversion utility which supports Cypress, Xilinx and Altera file formats. The software, in conjunction with Atmel ISP cable, can be used to download an Atmel, Cypress, Xilinx or Altera programming file directly to Atmel's configurator(s).

- CPS – Configurator Programming System
- GUI Bbased Interface
- Supports Windows® 95/98/2000 and Windows NT®
- Supports up to 8 devices
- Supports programming reset polarity
- Verification routines to validate programming
- Accepts HEX, MCS, POF, RBF, HXU and BST file formats
- Online help
- Ability to enable or disable internal oscillator

For specific information on using the CPS software, refer to the *ATDH2200E Programming Kit User Guide*.



In-System Programming Cable

ATDH2225 FPGA Configuration EEPROM Memory



Connecting Cable to Target System

The cable draws its power from the target system through VCC and GND. Therefore, power to the cable, as well as to the target FPGA, must be stable. Do not connect any signals before connecting VCC and GND. Connect the programming dongle to your printer parallel port. Connect the other end with 10-pin header to your target system (Figure 1). Your target system should have the 10-pin header pin layout as follow in order to match the download cable (Figure 2). The pin 9 of the 10-pin header on the target system is a key pin; therefore, it is cut off. The control signals generated by the software are fed to the header. The programming algorithms written by Atmel can be used to program an AT17 device in-system.

Figure 1. In-System Programming Application

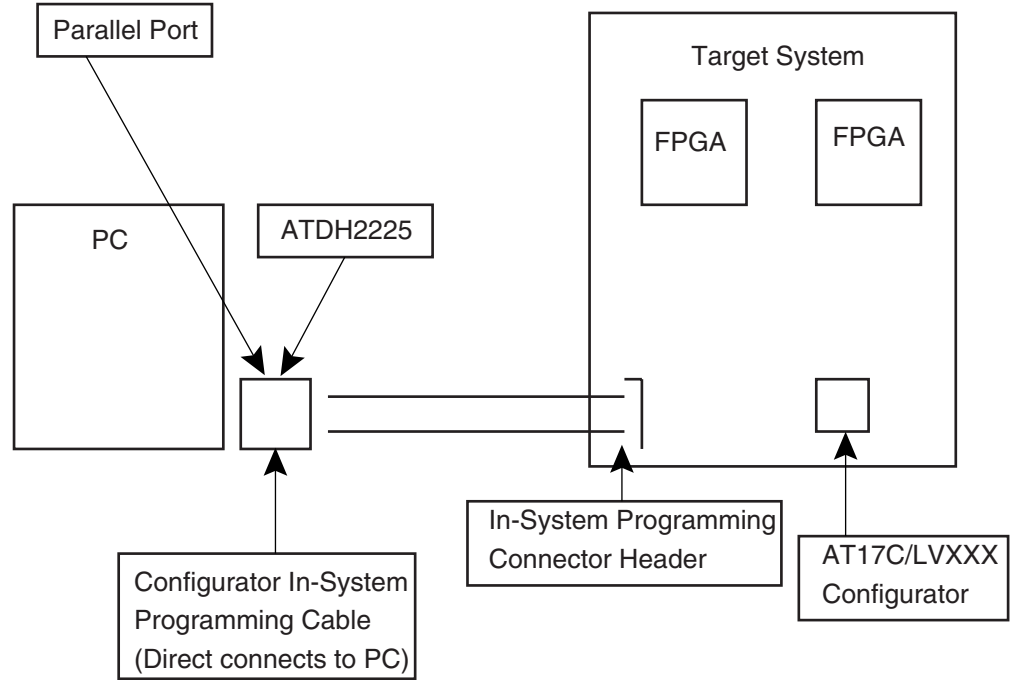

Figure 2. In-System Programming Header

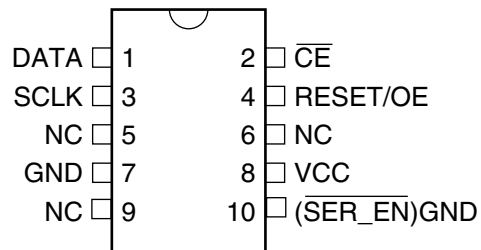

Table 1. 10-pin Header Pin Location on Target Board

1(DATA)	2(\overline{CE})
3(SCLK)	4(RESET/OE)
5(SW1)	6(SW2)
7(GND)	8(VCC)
9(NC)	10(SER_EN/GND)

- Notes:
1. Pin 10 activates "SER_EN" on target board.
 2. Pin 9 is the polarizing pin (cut off).
 3. The 10-pin header is 0.1" spacing

Pin 5 and Pin 6 of the 10-pin header are the two signals which are able to decode for cascading up to 8 devices. The latest CPS software has the ability to control the 2 signals SW1, SW2 and by using the A2 pin of the device, you can select up to 8 devices. Therefore, you could use a 2-to-4 decoder to cascade 8 devices using our existing ISP circuit (see Figure 3).

Figure 3. ISP of Cascaded AT17C/LV002s in AT40K FPGA Applications

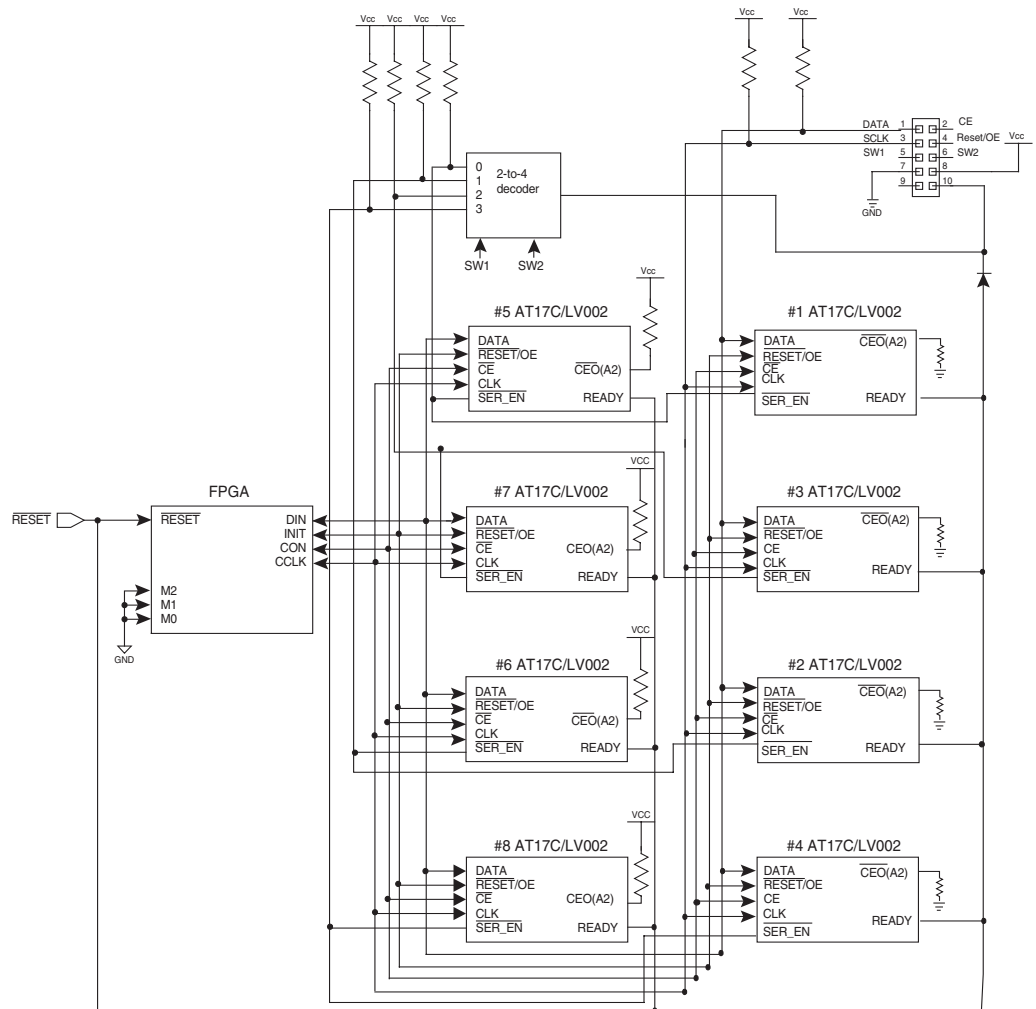

Table 2. 2 Devices

Device	A2
Device #1	pull down
Device #2	pull up

Note: No additional logic required, SW1 and SW2 not used.

Table 3. 4 Devices

Device	SW1	A2
Device #1	0	pull down
Device #2	1	pull down
Device #3	0	pull up
Device #4	1	pull up

Note: SW1 and some additional logic required for selecting up to 4 devices.

Table 4. 8 Devices

Device	SW1	SW2	A2
Device #1	0	0	pull down
Device #2	0	1	pull down
Device #3	1	0	pull down
Device #4	1	1	pull down
Device #5	0	0	pull up
Device #6	0	1	pull up
Device #7	1	0	pull up
Device #8	1	1	pull up

Note: SW1, SW2 and some additional logic required for selecting up to 8 devices.

Table 5. For 020 Max. is 4 Devices

Device	SW2	SW1
Device #1	0	0
Device #2	0	1
Device #3	1	0
Device #4	1	1

Note: 2 to 4 devices and some additional logic required for selecting up to 4 devices.

The AT17C/LV020 device is implemented using two 1-Mb Configurator EEPROMs in a multi-chip module. The A2 pin of the first internal 1Mb is set to Low by the internal pull-down circuitry. An external 4.7 kΩ pull-up must be connected to the A2 pin of the second internal 1Mb in order to program the second device. To work with the AT17C/LV020 devices, A2 should always have a pull up on the target system. The CPS software will implement the correct A2 value to program both internal devices. In fact, to program an AT17C/LV020 is just like programming two 1-Mb Configurator EEPROMs in casacade configuration.

Due to the fact that the AT17C/LV002 device is a single-die solution, an external pull-up or pull-down resistor can be connected to the A2 pin in order to program the data to the device. As long as the software A2 setting is matched with the hardware A2 pin setting, the data can be programmed to the device.

The tables on page 4 allow you to select any device out of the 8 devices, which can work with the ISP download cable. The circuit is limited to example implementation for the Atmel vendor only. It is the same idea for Xilinx and Altera applications. In addition, user can still use the existing ISP circuit, which from the 2-megabit cascade document with the same ISP download cable.

Related Documents

ATDH2200E Programming Kit User Guide

AT17C/LV device datasheet

Programming Specification for Atmel's FPGA Serial Configuration Memories

Technical Support

Use the ATDH2200E Programming Kit User Guide

Review the Configurator FAQ at www.atmel.com

Contact your local Atmel representative or distributor who provided the ISP download cable for technical support

Contact your local Atmel FAE (available at most sales offices)

Contact the Atmel configurator technical support hotline:

(408) 436-4119 (9:00 AM - 6:00 PM PST)

E-mail Atmel configurator technical support: configurator@atmel.com

Fax your inquires to "Configurator Tech Support" at:

(408) 487-2637

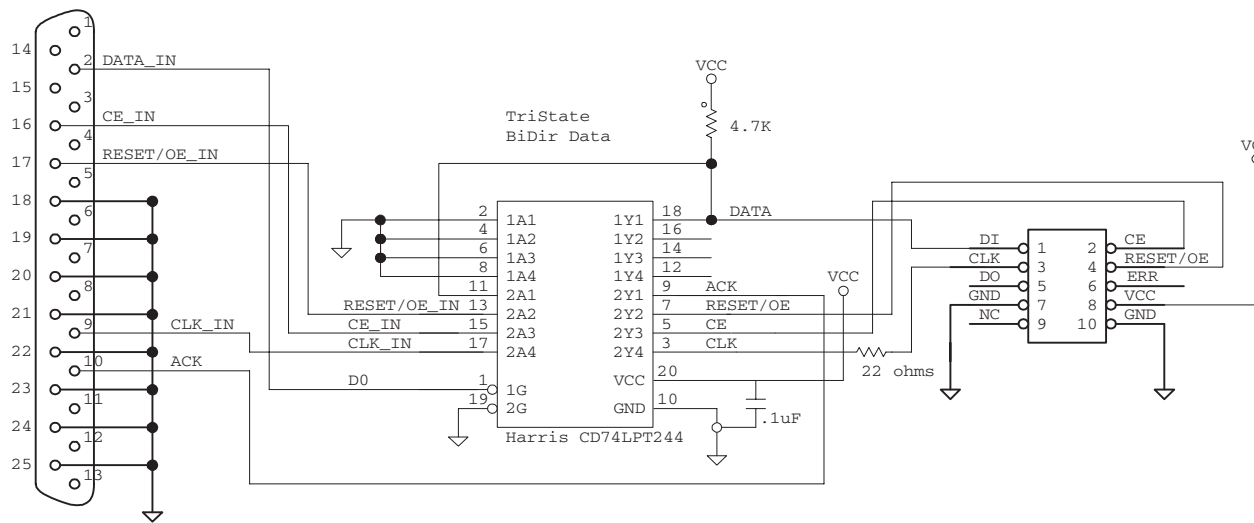

ATMEL CORPORATION	
Title: FPGA Configurator Programmer	
Size: A	Document Number: CHW5450 (ATDH2200)
Date: September 22, 1999	Sheet:



Atmel Headquarters

Corporate Headquarters

2325 Orchard Parkway
San Jose, CA 95131
TEL (408) 441-0311
FAX (408) 487-2600

Europe

Atmel SarL
Route des Arsenaux 41
Casa Postale 80
CH-1705 Fribourg
Switzerland
TEL (41) 26-426-5555
FAX (41) 26-426-5500

Asia

Atmel Asia, Ltd.
Room 1219
Chinachem Golden Plaza
77 Mody Road Tsimhatsui
East Kowloon
Hong Kong
TEL (852) 2721-9778
FAX (852) 2722-1369

Japan

Atmel Japan K.K.
9F, Tonetsu Shinkawa Bldg.
1-24-8 Shinkawa
Chuo-ku, Tokyo 104-0033
Japan
TEL (81) 3-3523-3551
FAX (81) 3-3523-7581

Atmel Operations

Atmel Colorado Springs

1150 E. Cheyenne Mtn. Blvd.
Colorado Springs, CO 80906
TEL (719) 576-3300
FAX (719) 540-1759

Atmel Rousset

Zone Industrielle
13106 Rousset Cedex
France
TEL (33) 4-4253-6000
FAX (33) 4-4253-6001

Atmel Smart Card ICs

Scottish Enterprise Technology Park
East Kilbride, Scotland G75 0QR
TEL (44) 1355-357-000
FAX (44) 1355-242-743

Atmel Grenoble

Avenue de Rochepleine
BP 123
38521 Saint-Egreve Cedex
France
TEL (33) 4-7658-3000
FAX (33) 4-7658-3480

Atmel Configurator Hotline

1-(408) 436-4119

Atmel Configurator e-mail

configurator@atmel.com

FAQ

Available on web site

Fax-on-Demand

North America:
1-(800) 292-8635
International:
1-(408) 441-0732

e-mail

literature@atmel.com

Web Site

<http://www.atmel.com>

BBS

1-(408) 436-4309

© Atmel Corporation 2001.

Atmel Corporation makes no warranty for the use of its products, other than those expressly contained in the Company's standard warranty which is detailed in Atmel's Terms and Conditions located on the Company's web site. The Company assumes no responsibility for any errors which may appear in this document, reserves the right to change devices or specifications detailed herein at any time without notice, and does not make any commitment to update the information contained herein. No licenses to patents or other intellectual property of Atmel are granted by the Company in connection with the sale of Atmel products, expressly or by implication. Atmel's products are not authorized for use as critical components in life support devices or systems.

Spartan and Virtex are the registered trademarks of Xilinx Corporation.

Windows® 95/98/2000 and Windows NT® are the registered trademarks of Microsoft Corporation.

Other terms and product names may be trademarks of others.



Printed on recycled paper.

X-ON Electronics

Largest Supplier of Electrical and Electronic Components

Click to view similar products for [Sockets & Adapters](#) category:

Click to view products by [Atmel](#) manufacturer:

Other Similar products are found below :

[6508-0-00-01-00-00-33-0](#) [AC164341](#) [AC164348](#) [1262](#) [C8051F350-TB](#) [KITPF0100SKTEVBE](#) [LFVDBJR](#) [SK-AX2-CQ256-KITTOP](#)
[AC164334](#) [AC164353](#) [AC164383](#) [SOCKET-ADM106XTQZ](#) [SPC564A80CAL176](#) [ST5M1267-001](#) [FP3-10PIN-ADAPTER-KIT](#) [CY3675-](#)
[LCC4A](#) [TDGL015](#) [ATF15XXDK3-SAA100](#) [LFBGADATC](#) [SM64TQ-ACTEL-1](#) [8.06.03](#) [AC164358](#) [ATSTK600-RC99](#) [76002056](#)
[DS91230+](#) [OM13019,598](#) [09185058](#) [AC164369](#) [AC164409](#) [AC164402](#) [SMPA-ISP-ACTEL-3-KIT](#) [ICESABCM81-01](#) [LFVDBGF](#)
[AC164408](#) [LFBGADAU1A](#) [KIT 70601-3](#) [S5U13U00P00C100](#) [AC164352](#) [PN-Q208/5256V](#) [PN-T100/LC4256](#) [LFBGAINTM55U1QA](#)
[AC164370](#) [AC164355](#) [AC164367](#) [LFDAS12XEFT](#) [CY3675-TSSOP20B](#) [SPC563M64AVB144](#) [ATF15XXDK3-SAA44](#) [AC164410](#)
[SPC563M64AVB176](#)