

FEATURES

- High Efficiency (Up to 92%)
- Wide Input Voltage Range (90-305VAC)
- Active Power Factor Correction (Up to 0.99)
- Waterproof IP67 for Damp and Wet Locations (see notes)
- Lightning Protection
- Class 2 Output (Some Models)
- Over Voltage, Over Temperature & Short Circuit Protection
- Compliant to UL8750 & EN61347 Safety Regulations
- Very High MTBF & Life Time
- Optional Dimming
- RoHS Compliant

96W Constant Current LED Driver LEDWCx096 Series



SPECIFICATIONS

Model	LEDWCx096S035ST	LEDWCx096S045ST	LEDWCx096S070ST	LEDWCx096S105ST	LEDWCx096S140ST	LEDWCx096S175ST (9)
Output						
Rated Current	350mA	450mA	700mA	1050mA	1400mA	1750mA
Current (Min/Max) mA	332 - 368	427 - 473	665 - 735	997 - 1102	1330 - 1470	1662 - 1837
Rated Power	96W	96W	96W	96W	96W	96W
Ripple & Noise (Max.) (1)	3% V _o					
Max. Voltage (With Load)	274 Vdc	213 Vdc	137 Vdc	92 Vdc	69 Vdc	54.8 Vdc
Max. Voltage (No Load)	278 Vdc	216 Vdc	140 Vdc	95 Vdc	72 Vdc	57 Vdc
Voltage Range (Min/Max)	137 - 274V	106V - 213V	68V - 137V	46V - 92V	35V - 69V	27V - 54.8V
Line Regulation	1%					
Load Regulation	5%					
Start Up Delay (Typ.)	0.8 S					
Input						
Voltage Range	90V - 305VAC					
Frequency Range	47Hz / 63Hz					
Power Factor	99% @ 110 VAC 96% @ 220 VAC					
Efficiency (Typ.) 220Vac	92%	92%	91%	91%	90%	90%
Inrush Current	50A @ 230VAC Input and 25°C					
Leakage Current	1 mA max. at 277 Vac 50Hz input					
AC Current (Typ.)	1.2 A / 100VAC 0.6A / 220VAC					
Protections						
Short Circuit	Hiccup mode, recovers automatically after fault condition is removed					
Over Temperature	110°C Temperature of components inside the case, recovers automatically after cooling.					
Over Voltage (Typ.)	300V	240V	160V	110V	90V	65V
	Latch-off mode, cycle AC to restart power supply					
Environmental						
Temperature Range	Operational	- 35°C - 70°C (10)				
	Storage	- 40 - +85°C				
Humidity	Operational	10 - 100% RH				
	Storage	5 - 100% R.H				
Safety & EMC						
Safety Standards	UL8750 , UL1310 (Class2), UL1012, CSA-C22.2 No. 223-M91 and No. 107.1					
CE	EN 61347-1, 2-13					
Withstand Voltage	I/P - O/P: 3KVAC (4242 DC) I/P - FG: 1.5KVAC (2121 DC) O/P-FG: 0.5KVAC (707 DC), 1 minute					
EMI Cond. & Rad.	EN55015 with 6db margin					
Harmonic Current	EN61000-3-2 , EN61000-3-3					
EMS Immunity	EN61000-4-2 (11), EN61000-4-3, EN61000-4-4, EN61000-4-5 (12) EN61000-4-6, EN61000-4-8, EN61000-4-11, EN 61547					
Others						
MTBF (2)	400K HRS Compliance: MIL-HDBK-217F					
Life Time (2)	50,000 hours @ 60°C case temperature					
Dimension (L*W*H)	174*67.5*37.0 (mm) or 6.85*2.66*1.46 (inch)					
Weight	850 g					

Model		LEDWCx096S210ST (9)	LEDWCx096S245ST (7,8)	LEDWCx096S280ST (7,8)	LEDWCx096S315ST (7,8)	LEDWCx096S350ST (7,8)	LEDWCx096S400xT (6)
Output	Rated Current	2100mA	2450mA	2800mA	3150mA	3500mA	4000mA
	Current (Min/Max) mA	1995 - 2205	2327 - 2572	2660 - 2940	2992 - 3307	3320 - 3680	3800 - 4200
	Rated Power	96W	96W	96W	96W	96W	96W
	Ripple & Noise (Max.) (1)	3% V _o					
	Max. Voltage (With Load)	45.7 Vdc	39.1 Vdc	34.2 Vdc	30.4 Vdc	27.4 Vdc	24 Vdc
	Max. Voltage (No Load)	48 Vdc	42 Vdc	37 Vdc	32 Vdc	29 Vdc	26 Vdc
	Voltage Range (Min/Max)	22V - 45.7V	19V - 39.1V	17V - 34.2V	15V - 30.4V	13V - 27.4V	12V - 24V
	Line Regulation	1%					
	Load Regulation	5%					
	Start Up Delay (Typ.)	0.8 S					
Input	Voltage Range	90V - 305VAC					
	Frequency Range	47Hz / 63Hz					
	Power Factor	99% @ 110 VAC 96% @ 220 VAC					
	Efficiency (Typ.) 220Vac	89%	89%	89%	88%	88%	88%
	Inrush Current	50A @ 230VAC Input and 25 °C					
	Leakage Current	1 mA max. at 277 Vac 50Hz input					
	AC Current (Typ.)	1.2 A / 100VAC 0.6A / 220VAC					
Protections	Short Circuit	Hiccup mode, recovers automatically after fault condition is removed					
	Over Temperature	110°C Temperature of components inside the case, recovers automatically after cooling.					
	Over Voltage (Typ.)	55V	50V	45V	40V	35V	30V
Environmental	Temperature Range	Operational	- 35°C ~ 70°C (10)				
		Storage	- 40 ~ +85°C				
	Humidity	Operational	10 ~ 100% RH				
		Storage	5 ~100% R.H				
Safety & EMC	Safety Standards	UL8750 , UL1310 (Class2), UL1012, CSA-C22.2 No. 223-M91 and No. 107.1					
	CE	EN 61347-1, 2-13					
	Withstand Voltage	I/P - O/P: 3KVAC (4242 DC) I/P - FG: 1.5KVAC (2121 DC) O/P-FG: 0.5KVAC (707 DC), 1 minute					
	EMI Conduction & Radiation	EN55015 with 6db margin					
	Harmonic Current	EN61000-3-2 , EN61000-3-3					
	EMS Immunity	EN61000-4-2 (11), EN61000-4-3, EN61000-4-4, EN61000-4-5 (12) EN61000-4-6, EN61000-4-8, EN61000-4-11, EN 61547					
Others	MTBF (2)	400K HRS Compliance: MIL-HDBK-217F					
	Life Time (2)	50,000 hours @ 60°C case temperature					
	Dimension (L*W*H)	174*67.5*37.0 (mm) or 6.85*2.66*1.46 (inch)					
	Weight	850 g					

Model	LEDWCx096S035ST	LEDWCx096S045ST	LEDWCx096S070ST	LEDWCx096S105ST	LEDWCx096S140ST	LEDWCx096S175ST	LEDWCx096S210ST	LEDWCx096S245ST	LEDWCx096S280ST	LEDWCx096S315ST	LEDWCx096S350ST	LEDWCx096S400ST
Efficiency @ 115VAC (min) (4)	89.0%	89.0%	88.0%	88.0%	87.0%	87.0%	86.0%	86.0%	86.0%	85.0%	85.0%	85.0%
Efficiency @ 115VAC (typ) (4)	90.0%	90.0%	89.0%	89.0%	88.0%	88.0%	87.0%	87.0%	87.0%	86.0%	86.0%	86.0%
Efficiency @ 230VAC (min) (5)	91.0%	91.0%	90.0%	90.0%	89.0%	89.0%	88.0%	88.0%	88.0%	87.0%	87.0%	87.0%
Efficiency @ 230VAC (typ) (5)	92.0%	92.0%	91.0%	91.0%	90.0%	90.0%	89.0%	89.0%	89.0%	88.0%	88.0%	88.0%

NOTES:

1. Measured with a 20MHz bandwidth oscilloscope and the output paralleled with a 0.1uf ceramic capacitor and a 10 uf electrolytic capacitor.
2. Calculation based on highest output current model at 110VAC input, 80% load and 25°C ambient temperature
3. All parameters NOT specially mentioned are measured at 220VAC input, rated load and 25°C of ambient temperature.
4. Measured at full load, 110VAC input, 25°C ambient temperature, after the unit is thermally stabilized.
5. Measured at full load, 220Vac input, 25°C ambient temperature, after the unit is thermally stabilized.
6. Class 2 output dry, damp and wet locations: USR and CNR
7. Class 2 output dry and damp locations : USR and CNR
8. Class 2 output wet locations: CSA only
9. Class 2 output dry and damp locations: USR only
10. Maximum case temperature 89°C
11. Electrostatic Discharge: 15 kV air discharge, 8 kV contact discharge
12. Surge Immunity Test: AC Power Line: line to line 2 kV, line to earth 4 kV

Specifications are subject to change without notice. Autec cannot be held liable for errors or omissions or the consequences thereof.

Part Number Builder

LEDWCx096SXXXST

LED Driver
 W = Wide Range Input
 C = Constant Current
 D = Dimming
 - = Non Dimming

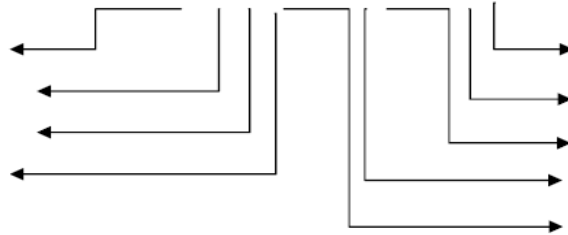

T = 3 Wire Input
 S = Standard
 Rated Current
 S = Single Output
 Total Power

Dimming Control 10-100%

Parameter	Min.	Typ.	Max.
Voltage on the 1-10V input pin	0V	-	12V
Source current on 1-10V input pin	0 mA	-	0.5mA
R Value (Input Line)	19.8 K	20 K	20.2 K

DC input Option

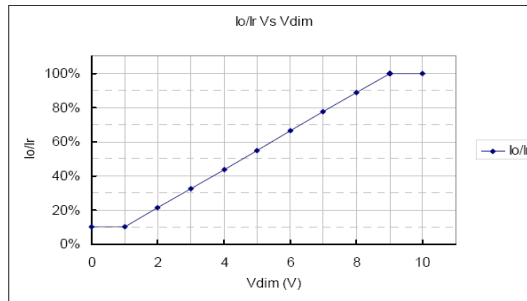
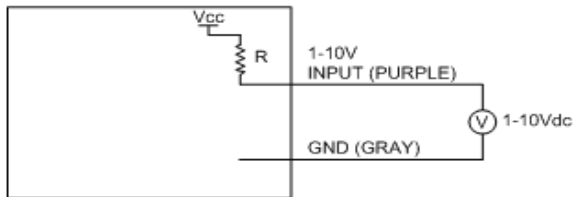

External Resistor Option

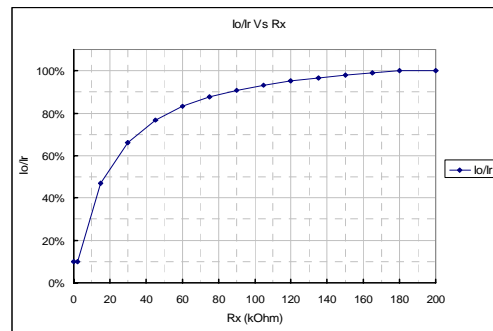
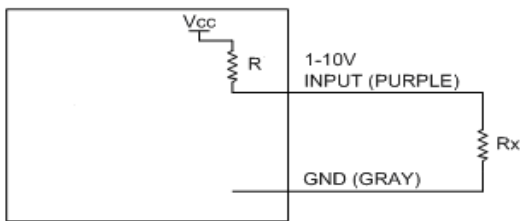

Notes:

1. Io is actual output current and Ir is rated current without dimming control.
2. Do not connect the GND of dimming to the output; otherwise, the LED driver can not work normally.
3. Suggested options shown.

■ Mechanical Specifications

Dimming Model

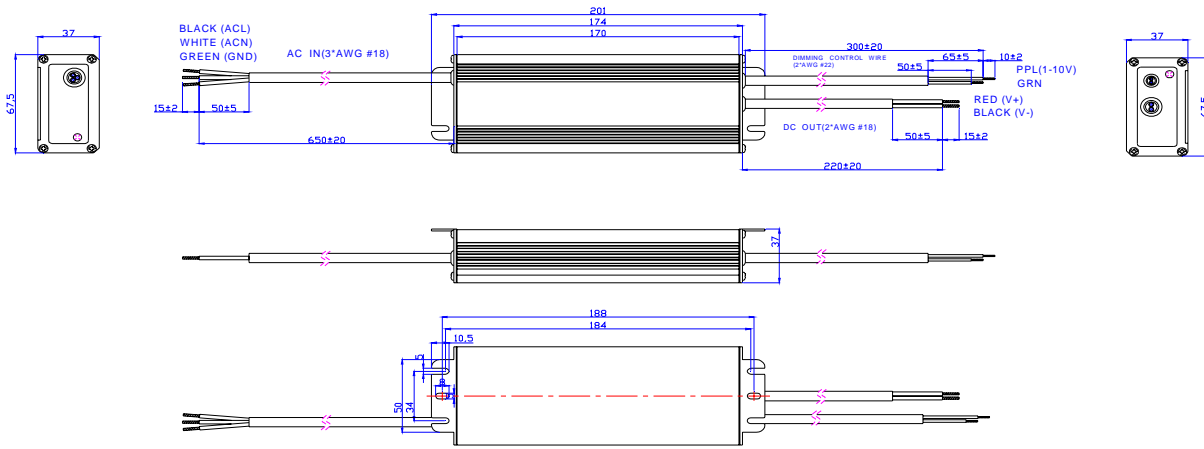

Non-Dimming Model

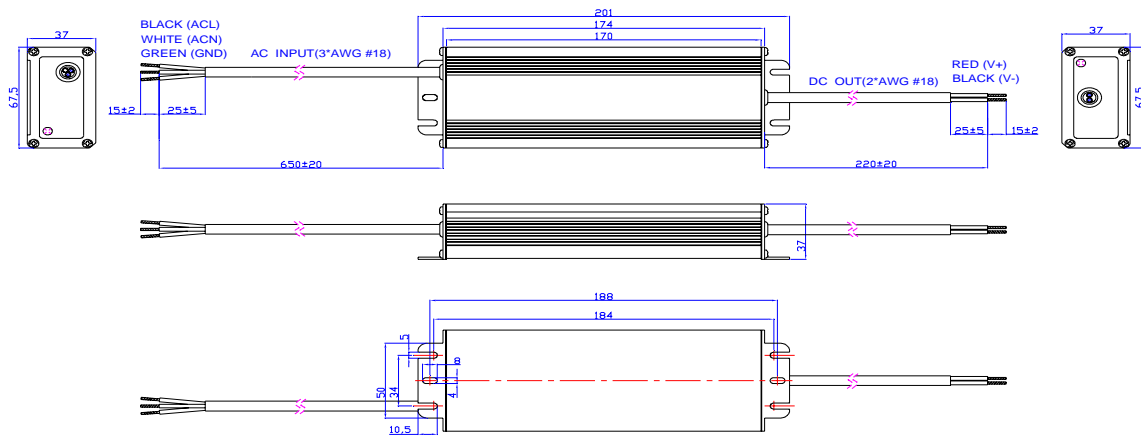

X-ON Electronics

Largest Supplier of Electrical and Electronic Components

Click to view similar products for [LED Lighting Drivers](#) category:

Click to view products by [Autec Power Systems](#) manufacturer:

Other Similar products are found below :

[LV5235V-MPB-H](#) [MB39C602PNF-G-JNEFE1](#) [FAN5701UMP20X](#) [FAN5702UMP30X](#) [MIC2871YMK-T5](#) [MP1518DJ-LF-P](#) [MP3202DG-LF-P](#) [MP3304BDD-LF-P](#) [MP3306EG-LF-P](#) [MP3398AGY](#) [MP4033GK](#) [AL1676-10BS7-13](#) [AL1676-20AS7-13](#) [MX877RTR](#)
[NCL30085BDR2G](#) [ICL8201](#) [IS31BL3506B-TTLS2-TR](#) [PAM2841GR](#) [A8519KLPTR-T](#) [FAN5701UMP08X](#) [FAN5702UMP20X](#) [AL3157F-7](#)
[AL8807BQMP-13](#) [LV52204MTTBG](#) [MP2488DN-LF](#) [MP24893DQ-LF-P](#) [MP24894GJ-P](#) [MP24895GJ-P](#) [MP3308DL-LF-Z](#) [MP3393EF-LF](#)
[MP3394SGF](#) [MP3802DQ-LF-P](#) [MP4008GS](#) [MP4031GS](#) [MP4032-1GS](#) [MP4034GS](#) [MP46885DN-LF](#) [SLG7NT4082V](#) [SLG7NT4082VTR](#)
[PCA9955BTWQ900J](#) [TLD5095EL](#) [LED6001TR](#) [STP4CMPQTR](#) [BD1604MVV-E2](#) [MC10SX1130DG](#) [MAX16832CASAT](#)
[MAX16814CATP+](#) [NCL30086BDR2G](#) [NCL30088BDR2G](#) [IS31LT3350-V1SDLS2-EB3CH](#)