

# SPR1/SPR3 Series

## Single-Phase/3-Phase, Slim Power Controller

### ■ Features

- Refine and slim body design
- LED display for real time monitoring (control input, load voltage, load current, load power, load resistance and heatsink temperature) and checking parameter settings
- Stable control by feedback control (constant current/constant voltage/constant power control)
- Communication output model available: RS485 (Modbus RTU method)
- Convenient parameter settings via PC (RS485 communication)  
: Free download the comprehensive device management program (DAQMaster)
- Various alarm functions (alarm output)  
: overcurrent, overvoltage, heatsink overheat, fuse break, SCR error
- Easy installation of the bracket
- Simple fuse replacement structure for easy maintenance
- Interphase insulating barrier included - SPR series
- Highly reliable SCR (IXYS) element

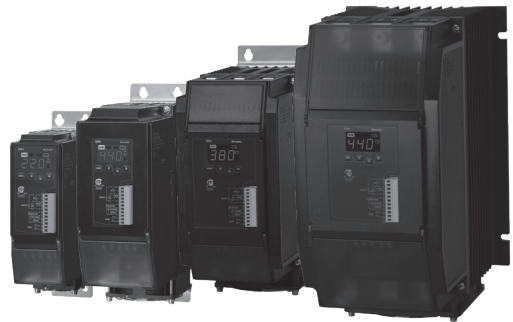

**⚠ Please read "Safety Considerations" in the instruction manual before using.**



### ■ Manual

- For the detail information and instructions, please refer to user manual for communication, and be sure to follow cautions written in the technical descriptions (catalog, website). Visit our website ([www.autonics.com](http://www.autonics.com)) to download manuals.
- User manual for communication manual describes for RS485 communication (Modbus RTU protocol) and parameter address map data.

### ■ Comprehensive Device Management Program (DAQMaster)

- DAQMaster is a comprehensive device management software for setting parameters and monitoring processes.
- Visit our website ([www.autonics.com](http://www.autonics.com)) to download user manual and comprehensive device management program.

< Computer specification for using software >

Item	Minimum specifications
System	IBM PC compatible computer with Pentium III or above
Operations	Windows 98/NT/XP/Vista/7/8/10
Memory	256MB+
Hard disk	1GB+ of available hard disk space
VGA	Resolution: 1024×768 or higher
Others	RS232C serial port (9-pin), USB port

< DAQMaster screen >

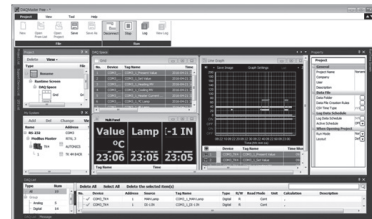

### ■ Ordering Information

SPR 1 - 2 70 T F F

Fuse	N	Non-fuse <sup>*1</sup>		
	F	Fuse		
Feedback control	N	Normal control		
	F	Normal/constant current/constant voltage/constant power control		
Option output	N	Alarm output		
	T	Alarm+RS485 comm. output		
Rated load current	25	25A	70	70A
	35	35A	100	100A
	50	50A	150	150A
Rated load voltage	1	110VAC		
	2	220VAC		
	3	380VAC		
	4	440VAC		
Control phase	1	Single-phase		
	3	3-phase		
Item	SPR	Solid State Power Regulator (slim type)		

\*1: Product is not equipped with a rapid fuse inside. Install the suitable fuse for rated load current of the model separately. (The performance of the product is guaranteed only when using the fuse provided by us.)

# Single-Phase/3-Phase, Slim Power Controller

## ■ Specifications

Model	SPR1 -1□□□□	SPR1- 2□□□□	SPR1 -3□□□□	SPR1 -4□□□□	SPR3 -1□□□□	SPR3- 2□□□□	SPR3 -3□□□□	SPR3 -4□□□□
Control phase	Single-phase				3-phase			
Rated load voltage (50/60Hz)	110VAC~	220VAC~	380VAC~	440VAC~	110VAC~	220VAC~	380VAC~	440VAC~
Power supply	100-240VAC~ 50/60Hz							
Min. load current	1A							
Permissible voltage range	90 to 110% of rated voltage							
Power consumption	<ul style="list-style-type: none"> <li>Rated load current 25A/35A/50A: max. 7VA</li> <li>Rated load current 70A/100A/150A: max. 12VA</li> </ul>				<ul style="list-style-type: none"> <li>Rated load current 25A/35A/50A: max. 14VA</li> <li>Rated load current 70A: max. 22VA</li> <li>Rated load current 100A/150A: max. 32VA</li> </ul>			
Display method	3-digit 7-segment LED							
Indicator	<ul style="list-style-type: none"> <li>Operation indicator/Manual control indicator: green LED</li> <li>Alarm indicator/output indicator/unit (V, A) indicator: red LED</li> </ul>							
Control method	<ul style="list-style-type: none"> <li>Phase control: normal control mode, constant current/constant voltage/constant power feedback control mode</li> <li>Cycle control: fixed cycle control mode, variable cycle control mode</li> <li>ON/OFF control</li> </ul>				<ul style="list-style-type: none"> <li>Phase control: normal control mode, constant current/constant voltage/constant power feedback control mode</li> <li>Cycle control: fixed cycle control mode</li> <li>ON/OFF control</li> </ul>			
Applied load	<ul style="list-style-type: none"> <li>Phase control, ON/OFF control: resistance load, inductive load</li> <li>Cycle control: resistance load</li> </ul>							
Control input	<ul style="list-style-type: none"> <li>Auto control: DC4-20mA, 1-5VDC<math>\equiv</math>, ON/OFF contact (no-voltage input), pulse voltage (5-12VDC<math>\equiv</math>)</li> <li>Manual control: outside adjuster (10k<math>\Omega</math>), inside adjuster (output limit)</li> </ul>							
Digital input (DI)	RUN/STOP switching, AUTO/MAN switching, RESET							
Output	Alarm	250VAC~ 3A, 30VDC $\equiv$ 3A, 1c resistive load						
	Communication	RS485 communication output (Modbus RTU method), max. connection: 31 units						
Output range	<ul style="list-style-type: none"> <li>Phase control: 0 to 98%</li> <li>Cycle control: 0 to 100%</li> <li>ON/OFF control: 0%, 100%</li> </ul>							
Output accuracy	<ul style="list-style-type: none"> <li>Normal control: within <math>\pm 10\%</math> F.S. of rated load voltage</li> <li>Constant current feedback control: within <math>\pm 3\%</math> F.S. of rated load current</li> <li>Constant voltage feedback control: within <math>\pm 3\%</math> F.S. of rated load voltage</li> <li>Constant power feedback control: within <math>\pm 3\%</math> F.S. of rated load power</li> </ul>							
Set method	By front keys, by communication							
Functions		Output limit (OUT ADJ), AUTO/MAN selection, control method selection, RESET, SOFT START, SOFT UP/DOWN, output high/low limit, input correction, input slope correction, monitoring (control input, load voltage/current/power/resistance, power supply frequency, heatsink temperature)						
	Alarm	SCR error alarm, overcurrent alarm, heatsink overheat alarm, overvoltage alarm, fuse break alarm, frequency error alarm $\times 1$ , heater break alarm						
Cooling method	<ul style="list-style-type: none"> <li>Rated load current 25A/35A/50A: natural cooling</li> <li>Rated load current 70A/100A/150A: forced air cooling (with the cooling fan)</li> </ul>							
Insulation resistance	Over 200M $\Omega$ (at 500VDC megger)							
Dielectric strength	2,000VAC 50/60Hz for 1 min (between input terminals and power terminals)							
Output leakage current	Max. 10mA $rms$							
Noise immunity	$\pm 2$ kV the square wave noise (pulse width: 1 $\mu$ s) by the noise simulator							
Memory retention	Approx. 10 years (when using non-volatile semiconductor memory type)							
Vibration	Mechanical	0.75mm amplitude at frequency of 5 to 55Hz in each X, Y, Z direction for 2 hours						
	Malfunction	0.5mm amplitude at frequency of 5 to 55Hz in each X, Y, Z direction for 10 min						
Environment	Ambient temp.	-10 to 55 $^{\circ}$ C, storage: -20 to 80 $^{\circ}$ C						
	Ambient humi.	35 to 85%RH, storage: 35 to 85%RH						
Accessory	11-pin connector				11-pin connector, insulating barrier: 4			
Approval	CE				CE			
Weight $\times 2$	<ul style="list-style-type: none"> <li>Rated load current 25A/35A/50A : approx. 1.6kg (approx. 1.3kg)</li> <li>Rated load current 70A : approx. 1.65kg (approx. 1.35kg)</li> <li>Rated load current 100A/150A : approx. 3.2kg (approx. 2.8kg)</li> </ul>				<ul style="list-style-type: none"> <li>Rated load current 25A/35A/50A : approx. 4.9kg (approx. 4.1kg)</li> <li>Rated load current 70A : approx. 5kg (approx. 4.2kg)</li> <li>Rated load current 100A/150A : approx. 9.7kg (approx. 8.7kg)</li> </ul>			

$\times 1$ : Only for normal control model of SPR1 Series.

$\times 2$ : The weight includes packaging. The weight in parenthesis is for unit only.

$\times$ Environment resistance is rated at no freezing or condensation.

SENSORS

FIELD INSTRUMENTS

CONTROLLERS

MOTION DEVICES

SOFTWARE

(A) Temperature Controllers

(B) SSRs

(C) Power Controllers

(D) Counters

(E) Timers

(F) Digital Panel Meters

(G) Indicators

(H) Converters

(I) Digital Display Units

(J) Sensor Controllers

(K) Switching Mode Power Supplies

(L) Recorders

(M) HMIs

(N) Industrial PC

(O) Field Network Devices

# SPR1/SPR3 Series

## Unit Description

### SPR1 Series

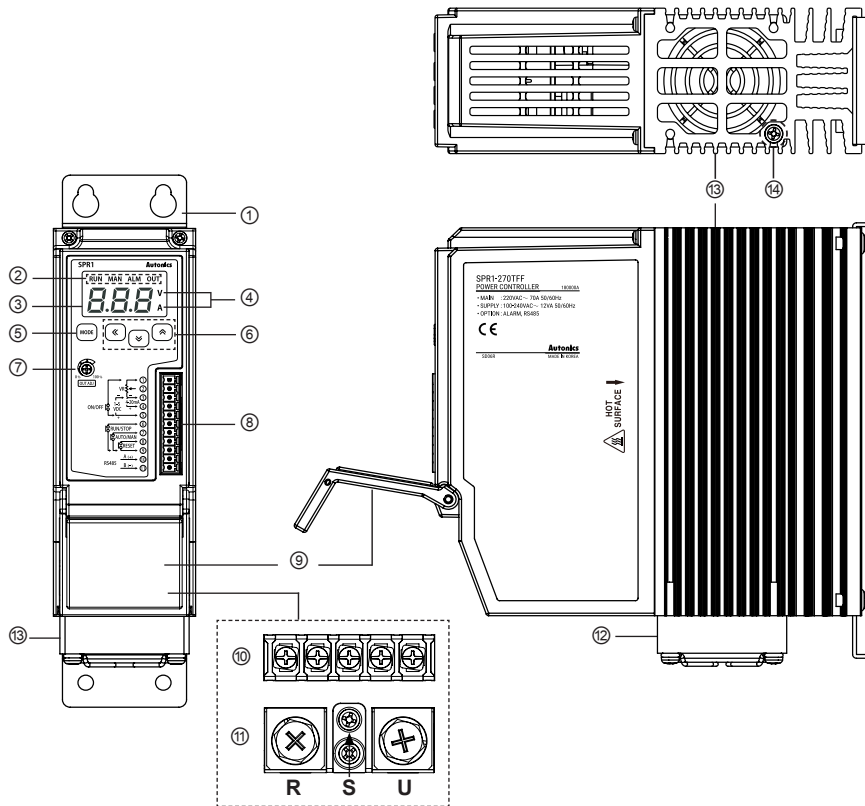

- ① Bracket
- ② Indicator

Indicator	Color	Function	
RUN	Operation indicator	Green LED	Turns on in the RUN mode.
MAN	Manual control indicator	Green LED	Turns on when adjusting load output in the manual control mode.
ALM	Alarm indicator	Red LED	Flashes in alarming status.
OUT	Output indicator	Red LED	Turns on when load control outputs.

- ③ Display part: Displays settings of the front display [ d' 5 ] parameter in RUN mode, and displays parameter and setting value in setting mode.
- ④ Unit indicator (☀: Light ON/●: Light OFF)

Indicator		Display
V	A	
●	●	Resistance, load
☀	●	Voltage
●	☀	Current
☀	☀	Power

- ⑤ **MAN** key: Enters parameter group, returns to RUN mode, moves parameters, and saves the setting value.
- ⑥ Setting value adjustment key: Enters SV setting mode and move digits.
- ⑦ Output limit adjuster (OUT ADJ): Limits output from 0 to 100%.
- ⑧ 11-pin connector terminal
- ⑨ Terminal cover
- ⑩ Alarm output and power input terminals
- ⑪ R, S, U load output terminals
- ⑫ Cooling fan: For models with the rated load current of 70A/100A/150A, a cooling fan is attached.
- ⑬ Heatsink
- ⑭ Bolt for grounding (M4)

# Single-Phase/3-Phase, Slim Power Controller

## ◎ SPR3 Series

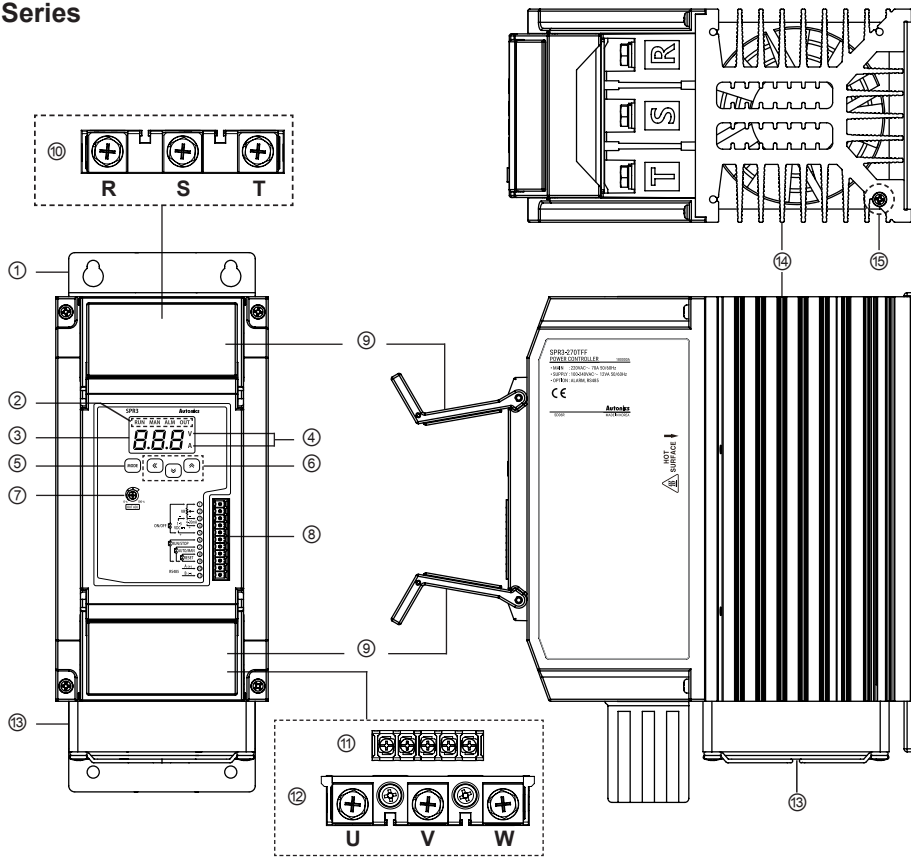

- ① Bracket (except rated load current 100A/150A models)
- ② Indicator

Indicator	Color	Function
RUN	Green LED	Turns on in the RUN mode.
MAN	Green LED	Turns on when adjusting load output in the manual control mode.
ALM	Red LED	Flashes in alarming status.
OUT	Red LED	Turns on when load control outputs.

- ③ Display part: Displays settings of the front display [ d1 5 ] parameter in RUN mode, and displays parameter and setting value in setting mode.
- ④ Unit indicator (☀️: Light ON/●: Light OFF)

Indicator		Display
V	A	Resistance, load
●	●	Voltage
☀️	☀️	Current
●	☀️	Power

- ⑤ key: Enters parameter group, returns to RUN mode, moves parameters, and saves the setting value.
- ⑥ Setting value adjustment key: Enters SV setting mode and move digits.
- ⑦ Output limit adjuster (OUT ADJ): Limits output from 0 to 100%.
- ⑧ 11-pin connector terminal
- ⑨ Terminal cover
- ⑩ R, S, T load input terminal
- ⑪ Alarm output and power input terminals
- ⑫ U, V, W Load output terminals
- ⑬ Cooling fan: For models with the rated load current of 70A/100A/150A, a cooling fan is attached.
- ⑭ Heatsink: In case of rated load current 100A/150A models, there are mounting holes on the right/left.
- ⑮ Bolt for grounding (M4)

SENSORS
FIELD INSTRUMENTS
CONTROLLERS
MOTION DEVICES
SOFTWARE

(A) Temperature Controllers
(B) SSRs
(C) Power Controllers
(D) Counters
(E) Timers
(F) Digital Panel Meters
(G) Indicators
(H) Converters
(I) Digital Display Units
(J) Sensor Controllers
(K) Switching Mode Power Supplies
(L) Recorders
(M) HMIs
(N) Industrial PC
(O) Field Network Devices

# SPR1/SPR3 Series

## ■ Dimensions

### ◎ SPR1 Series

- Rated load current 25A/35A/50A

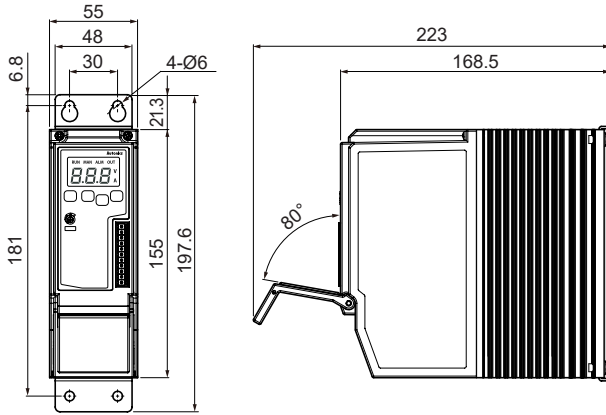

- Rated load current 70A

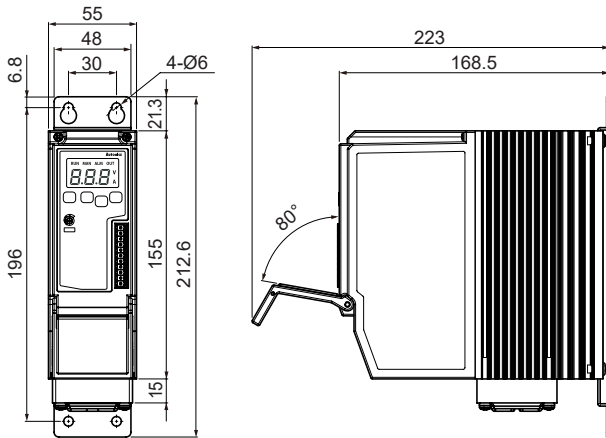

- Rated load current 100A/150A

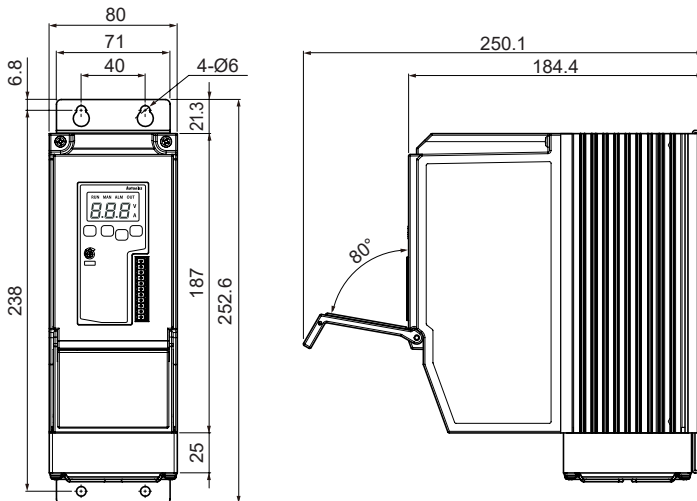

(unit: mm)

### ◎ Spacing

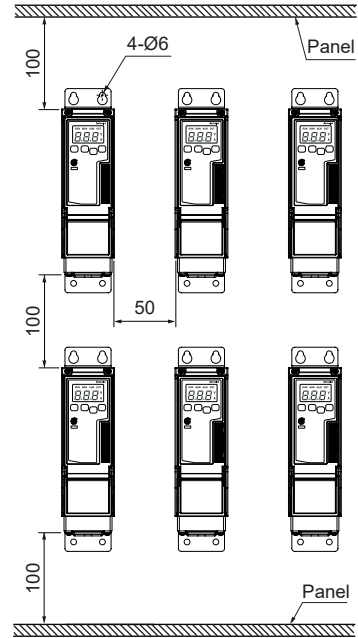

※When installing multiple power controllers, please keep space at least 50mm in horizontal and 100mm in vertical between power controllers for heat radiation.



### High Temperature Caution

While supplying power to the load or right after turning off the power of the load, do not touch the body and heatsink. Failure to follow this instruction may result in a burn due to the high temperature.

# Single-Phase/3-Phase, Slim Power Controller

## ◎ SPR3 Series

### • Rated load current 25A/35A/50A

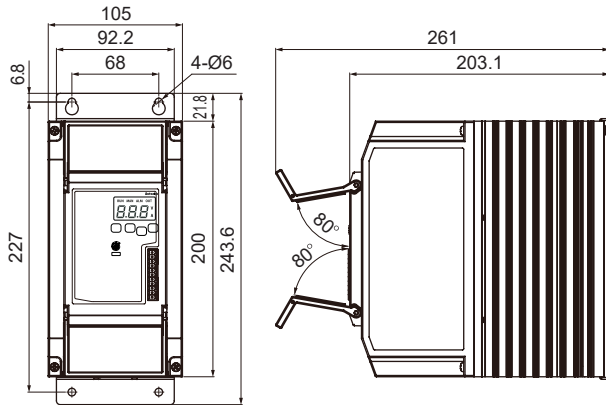

### • Rated load current 70A

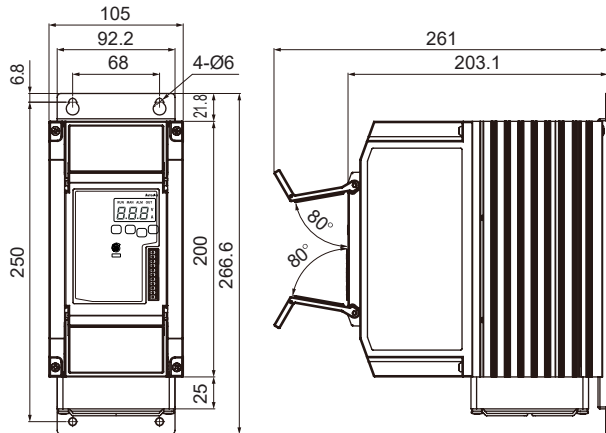

### • Rated load current 100A/150A

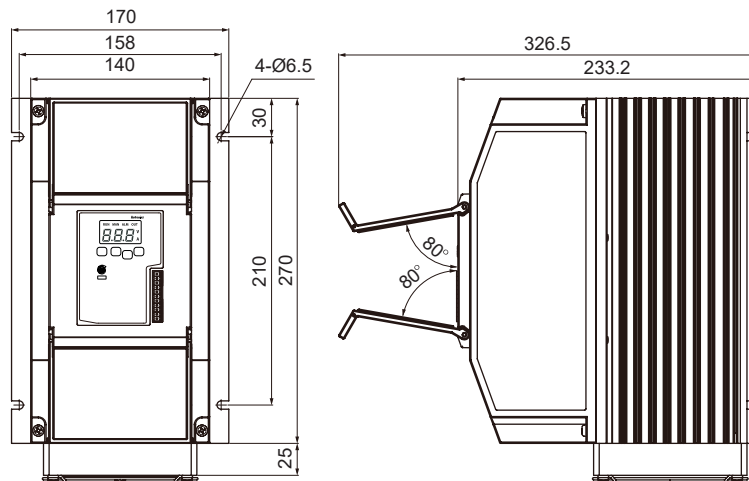

### • Insulating barrier

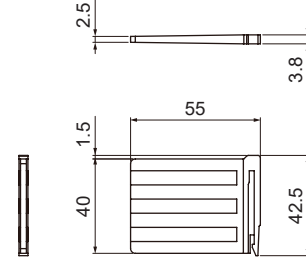

### - With the insulating barrier

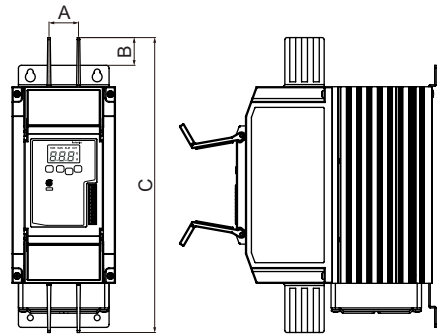

(unit: mm)

Rated load current	A	B	C
25A, 35A, 50A	30	28.2	300
70A	30	28.2	300
100A, 150A	40.5	50	370

※It is recommended to use the included interphase barriers for insulation between phases and reduce influence from conductive material.

SENSORS
FIELD INSTRUMENTS
<b>CONTROLLERS</b>
MOTION DEVICES
SOFTWARE
(A) Temperature Controllers
(B) SSRs
<b>(C) Power Controllers</b>
(D) Counters
(E) Timers
(F) Digital Panel Meters
(G) Indicators
(H) Converters
(I) Digital Display Units
(J) Sensor Controllers
(K) Switching Mode Power Supplies
(L) Recorders
(M) HMIs
(N) Industrial PC
(O) Field Network Devices

# SPR1/SPR3 Series

## ■ Connections

### ◎ Control input/Comm. output

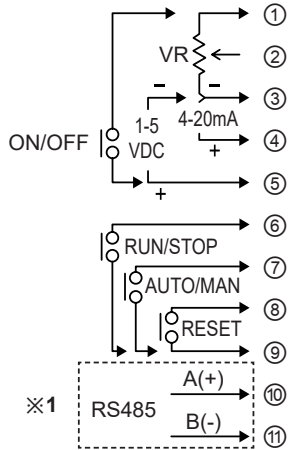

### ◎ Alarm output/power input

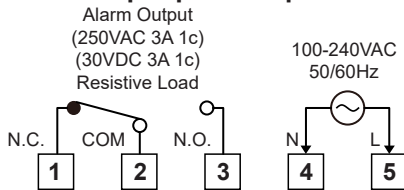

※1: This is only for models with RS485 communication output (SPR□-□□T□□).

※2: When connecting noise filter and capacitor, it is appropriate for EMC.

CAP : Rated load voltage 110VAC-220VAC → 1μF/250VAC

: Rated load voltage 380VAC-440VAC → 0.47μF/500VAC

※3: The normal control model does not connect S terminal and CAP for EMC.

※Tighten the terminal screw with the below tightening torque.

Rated load current	Specification	Alarm output/ power input	Load output (SPR1 Series)		Load input/output (SPR3 Series)
			S	R, U	
25A, 35A, 50A, 70A	Screw	M3	M3	M6	M6
	Tightening torque	0.5N·m	0.5N·m	5.5 to 6.0N·m	5.5 to 6.0N·m
100A, 150A	Screw	M3	M3	M8	M8
	Tightening torque	0.5N·m	0.5N·m	6.5 to 7.0N·m	6.5 to 7.0N·m

※Use crimp terminals or terminals of size specified below.

(unit: mm)

Terminal type	Terminal number	a	b	c
Input (11-pin)	1 to 11	6 to 7	Max. 1.5	Max. 3.5
Alarm output/ power input			Min. 3.0	Max. 6.0
	S		Min. 3.0	Max. 8.0
Load output (SPR1 Series)	R, U	Rated load current 25A/35A/50A/70A	Min. 6.0	Max. 16.0
		Rated load current 100A/150A	Min. 8.0	Max. 26.0
Load input/output (SPR3 Series)	R, S, T, U, V, W	Rated load current 25A/35A/50A/70A	Min. 6.0	Max. 16.0
		Rated load current 100A/150A	Min. 8.0	Max. 26.0

※Connect the specified wire as the rated load current.

Rated load current	Wire specification			
	Alarm output/ power input	Load output (SPR1 Series)		Load input/output (SPR3 Series)
25A/35A/50A/70A	AWG 18 to 14	S	R, U	AWG 13 to 4
100A/150A		AWG 18 to 14	AWG 13 to 4 AWG 4 to 2/0	AWG 13 to 4 AWG 4 to 2/0

### ◎ Load output (SPR1 Series)

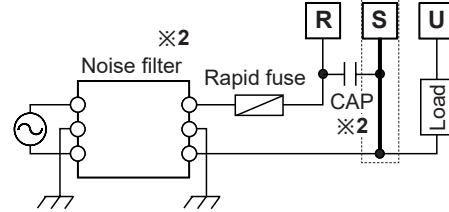

### ◎ Load input/output (SPR3 Series)

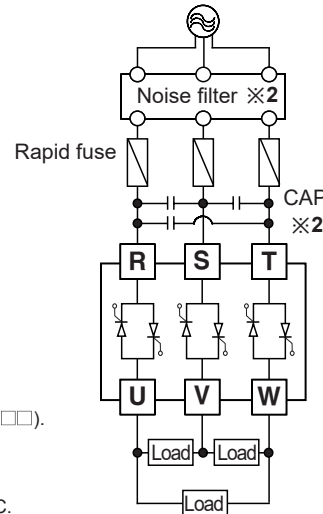

# Single-Phase/3-Phase, Slim Power Controller

## Derating Curve

### SPR1 Series

#### Rated load current 25A

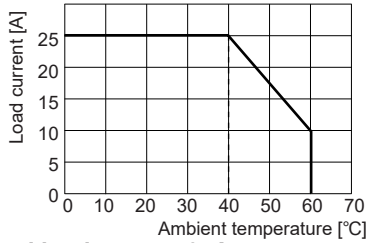

#### Rated load current 35A

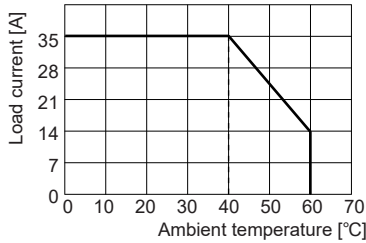

#### Rated load current 50A

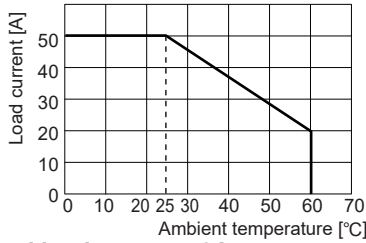

#### Rated load current 70A

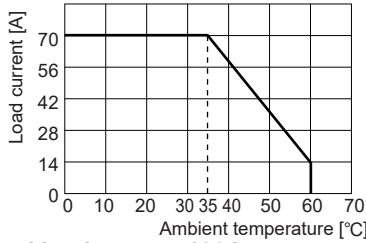

#### Rated load current 100A

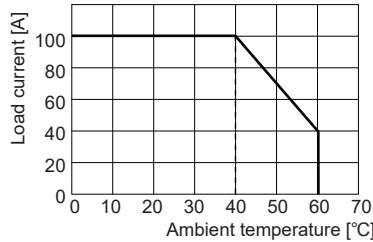

#### Rated load current 150A

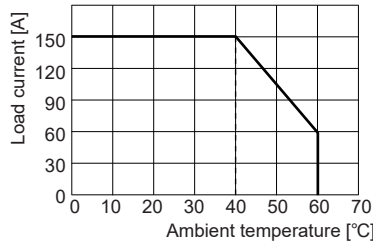

### SPR3 Series

#### Rated load current 25A

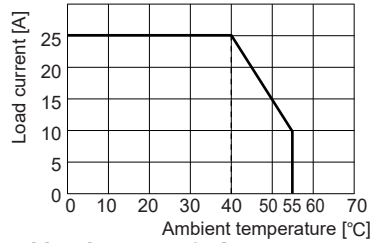

#### Rated load current 35A

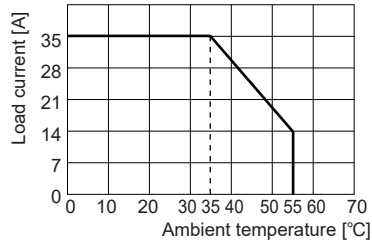

#### Rated load current 50A

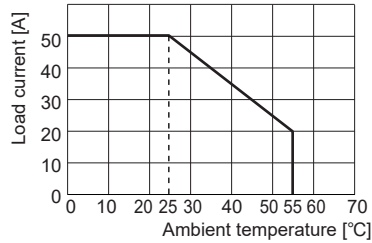

#### Rated load current 70A

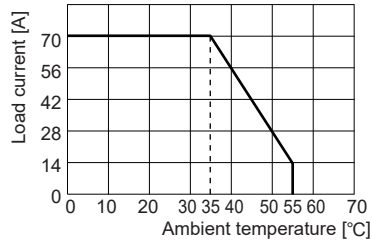

#### Rated load current 100A

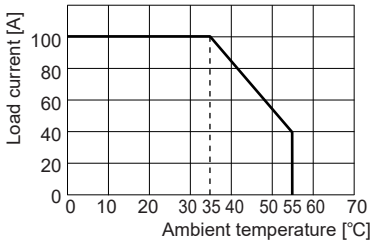

#### Rated load current 150A

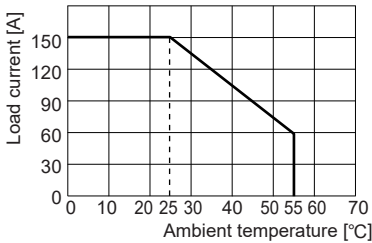

SENSORS
FIELD INSTRUMENTS
<b>CONTROLLERS</b>
MOTION DEVICES
SOFTWARE
(A) Temperature Controllers
(B) SSRs
<b>(C) Power Controllers</b>
(D) Counters
(E) Timers
(F) Digital Panel Meters
(G) Indicators
(H) Converters
(I) Digital Display Units
(J) Sensor Controllers
(K) Switching Mode Power Supplies
(L) Recorders
(M) HMI's
(N) Industrial PC
(O) Field Network Devices



# SPR1/SPR3 Series

## ■ Parameter Group

※Hold the **[MODE]** key in RUN mode to enter into parameter group.

※In parameter setting group, press the **[MODE]** key to move to other parameter in the group.

※Press the **[MODE]** key once after changing the setting value, to save the setting value and move to the next parameter.

※When entering to the parameter, press the **[←]** key to move digit, **[↑]**, **[↓]** keys to change the setting value.

※If there is no key input for 30 sec while setting SV or the parameters, the new settings are ignored, and the unit will return to RUN mode with previous settings.

※Hold the **[MODE]** key for 3 sec to save the setting value and return to RUN mode after changing the setting value.

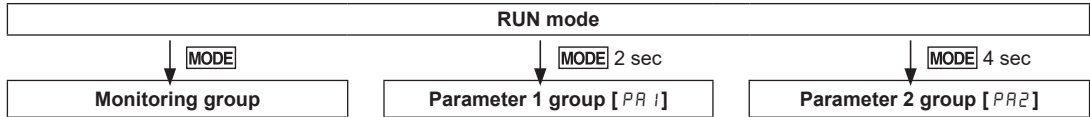

## ◎ Monitoring group

Display	Measuring range	Description	Unit	Factory default	
$i_n$	0 to 100	Displays the present control input as percentage.	%	—	
SPR1	$L-U$ ※1	0 to rated voltage range	Displays the present load voltage.	V	—
	$L-A$ ※1	0 to rated current range	Displays the present load current.	A	—
SPR3	$U-U$ ※1	0 to rated voltage range	Displays the present load voltage between U-V line.	V	—
	$U-W$ ※1		Displays the present load voltage between V-W line.		
	$W-U$ ※1		Displays the present load voltage between W-U line.		
	$U-A$ ※1	0 to rated current range	Displays the present load current of U-phase.	A	—
	$V-A$ ※1		Displays the present load current of V-phase.		
	$W-A$ ※1		Displays the present load current of W-phase.		
$L-W$ ※1	0 to rated power range	Displays the present load power.	kW	—	
$L-r$ ※1	0 to 100	Displays the present resistance as percentage compared to the set resistance of full load auto recognition.	%	—	
$t_nP$	0 to 100	Displays the present temperature of heatsink.	°C	—	
$F_r9$	50, 60	Displays the present frequency of power supply.	Hz	—	

## ◎ Parameter 1 group [PR1]

Display	Setting range	Description	Unit	Factory default
$S-t$	0 to 100	Set SOFT START time.	sec	3
$U-t$	0 to 100	Set SOFT UP time.	sec	3
$d-t$	0 to 100	Set SOFT DOWN time.	sec	3
$L-L$	$0 \leq L-L \leq H-L \leq 100$	Set the output low-limit value.	%	0
$H-L$		Set the output high-limit value.	%	100
$SLP$ ※2	0 to 100	In case of auto control (AUTO), set the output slop limit proportional to control input for limit load power.	%	100

## ◎ Parameter 2 group [PR1]

Display	Setting range	Description	Unit	Factory default	
$i_n t$ ※2	$420$	DC4-20mA	Set the control input specification.	—	420
	$1-5$	1-5VDC			
	$512$	5-12VDC			
	$onF$	ON/OFF contact			
	$Co n$	RS485 comm.			
$C-n$	$PR$	Phase control- Normal	Set the control method. ※Cycle control-variable cycle [ $U-L$ ] is displayed only for SPR1 series.	—	$PR$
	$U-F$ ※1	Phase control - Constant voltage feedback			
	$C-F$ ※1	Phase control - Constant current feedback			
	$U-F$ ※1	Phase control - Constant power feedback			
	$F-C$	Cycle control - Fixed cycle			
	$U-C$	Cycle control - Variable cycle			
	$onF$	ON/OFF control			

# Single-Phase/3-Phase, Slim Power Controller

Display	Setting range		Description	Unit	Factory default	
$\bar{n}Rn$ ※2	$i_r$	Inside adjuster	In case of manual control (MAN), set the output limit method.	—	$i_r$	
	$E_r$	Outside adjuster				
	$E_i$	Inside/Outside adjuster				
$inb$ ※2	-99 to 99		Set the compensated input value for the offset between the actual input value and the measured input value.	%	00	
$SPn$ ※2	-99 to 99		Set the compensated input slope value between the actual input value 100% and the measured input value 100%.	%	00	
$d15$	$i_n$ Resistance and input		Set the desired value to be displayed at the front display part.	—	$i_n$	
	SPR1	$L-u$ ※1				Load voltage
		$L-R$ ※1				Load current
	SPR3	$U-u$ ※1				Load voltage between U-V line
		$u-w$ ※1				Load voltage between V-W line
		$w-U$ ※1				Load voltage between W-U line
		$U-R$ ※1				U-phase load current
		$u-R$ ※1				V-phase load current
		$w-R$ ※1				W-phase load current
$L-w$ ※1		Load power				
$oCu$ ※1	0 to 120		Set the overcurrent alarm value.	%	120	
$oCt$ ※1	0 to 100		Set the overcurrent alarm delay time.	sec	5	
$oUu$ ※1	0 to 120		Set the overvoltage alarm value.	%	120	
$oUt$ ※1	0 to 100		Set the overvoltage alarm delay time.	sec	5	
$F-L$ ※1	$oFF / on$		It executes 100% control output for 3 sec and the load resistance value recognized automatically as the initial set when the function is ON.	—	$oFF$	
$Hbu$ ※1	$oFF / 10$ to 100		Set the heater break alarm value.	%	10	
$Rdr$ ※3	01 to 99		Assign the unique address when communicating.	—	01	
$bPS$ ※3	24, 48, 96, 192, 384		Set the speed of data transmission. Multiply by 100 to read the set value. (e.g.: 96=9600bps)	bps	96	
$Prb$ ※3	$non / EuE / odd$		A parity bit is a data communication method that adds an additional bit to each character in transmitted data as an indicator used to verify data loss and corruption.	—	$non$	
$StP$ ※3	1, 2		Set the number of bits to mark the end of a transmitted data string.	bit	2	
$ryt$ ※3	5 to 99		Set standby time to prevent communication errors when communicating with a slow master device (PC, PLC, etc.).	ms	20	
$Enu$ ※3	$EnR$	Enable	Enable or disable the setting of parameters stored in memory via communication from the master system (PC, PLC, etc.). Reading the set value in parameter is always possible.	—	$EnR$	
	$dSR$	Disable				
$LoC$	$oFF$	Unlock	The parameter group settings can not be changed when the function is ON.	—	$oFF$	
	$LC1$	$PR1$ lock				
	$LC2$	$PR2$ lock				
$ini$	$no / YES$		If set the parameter to YES, reset all parameters to default. Hold the $\square$ , $\square$ , $\square$ keys for 5 sec, to enter parameter reset parameter.	—	$no$	

※1: Displayed only for feedback control models.

※2: Set the below parameters available depends on the control input.

Type	Input		Display	Input correction [i nb]	Input slope correction [SPn]	Output slope [SLP]	Monitoring value [i n]	
Auto control (AUTO)	Current	DC4-20mA	$int$	420	○	○	The last control input value 0 to 100%	
	Voltage	1-5VDC		1-5	○	○		
	pulse voltage	5-12VDC		512	×	×		○
	No-voltage	ON/OFF contact		onF	×	×		○
	RS485 communication			Loñ	×	×		×
Manual control (MAN)	Output limit	Inside adjuster	$\bar{n}Rn$	$i_r$				
		Outside adjuster		$E_r$	×	×	×	
		Inside/outside adjuster		$E_i$				

※3: Displayed only for models with RS485 comm. output.

SENSORS
FIELD INSTRUMENTS
CONTROLLERS
MOTION DEVICES
SOFTWARE
(A) Temperature Controllers
(B) SSRs
(C) Power Controllers
(D) Counters
(E) Timers
(F) Digital Panel Meters
(G) Indicators
(H) Converters
(I) Digital Display Units
(J) Sensor Controllers
(K) Switching Mode Power Supplies
(L) Recorders
(M) HMIs
(N) Industrial PC
(O) Field Network Devices

# SPR1/SPR3 Series

## Load Output Formula

Type	Input		Display	Formula
Auto control (AUTO)	Current	DC4-20mA	420	Load output [%] = Control input [%] × Output slope (S <sub>L.P</sub> ) [%]
	Voltage	1-5VDC	1-5	
	RS485 communication		RS485	Load output [%] = RS485 [%]
Manual control (MAN)	Output limit	Inside adjuster	I <sub>in</sub>	Load output [%] = Inside adjuster [%]
		Outside adjuster	E <sub>in</sub>	Load output [%] = Outside adjuster [%]
		Inside/outside adjuster	E <sub>in</sub>	Load output [%] = Inside adjuster [%] × Outside adjuster [%]

## Control Method

### Phase control

#### Normal control mode

It is general output method to divide control angle proportionally according to control input signal and to output it.

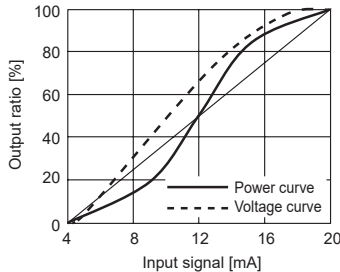

#### Constant current feedback control mode

If temperature coefficient of load (platinum, molybdenum, tungsten, etc) changes 6 to 12 times based on room temperature, it outputs constant current which is proportion to control input not to change output voltage for power supply variation, load resistance variation.

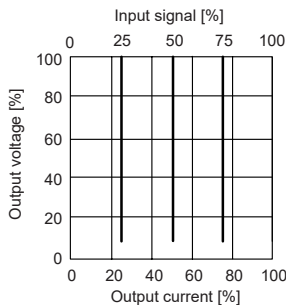

#### Constant voltage feedback control mode

At low temperature coefficient load (iron, chrome, nichrome, etc) of electrical resistance, it outputs constant output which is proportion to control input not to change output voltage for power supply variation, load resistance variation.

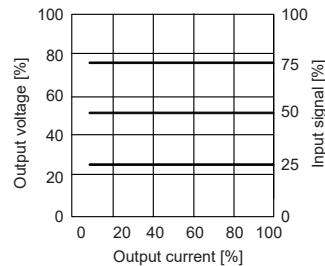

#### Constant power feedback control mode

It is proper control method for a heater which resistance value variation by silicon carbide (SiC) heating is big. It outputs constant power which is proportion to control input even though load variation and power supply variation.

Output characteristics is proper 50% of the curve which connects the point (A) [output voltage 100% × output current 50%] and the point (B) [output voltage 50% × output current 100%]. The current output capacity of this unit should be over two times of load capacity.

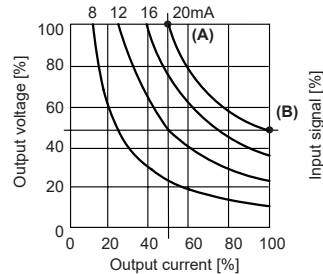

### Cycle control

#### Fixed cycle control mode

During fixed cycle (60 cycles) of load power, it repeats ON/OFF cycle as constant ratio according to control input signal and controls the power supplies on the load.

E.g.) When controlling output as 40%

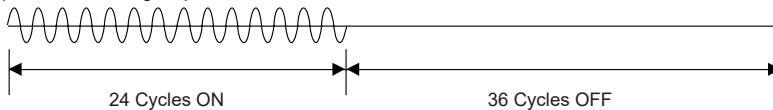

E.g.) When controlling output as 90%

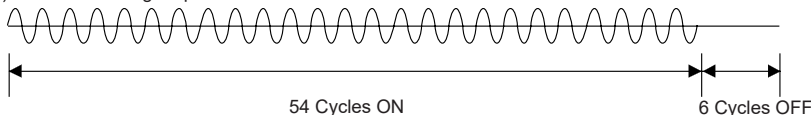

# Single-Phase/3-Phase, Slim Power Controller

## • Variable cycle control mode

Variable cycle control controls required power using min. cycles of load power according to control input signal and optimize temperature changes of the subject.

E.g.) When controlling output as 30%

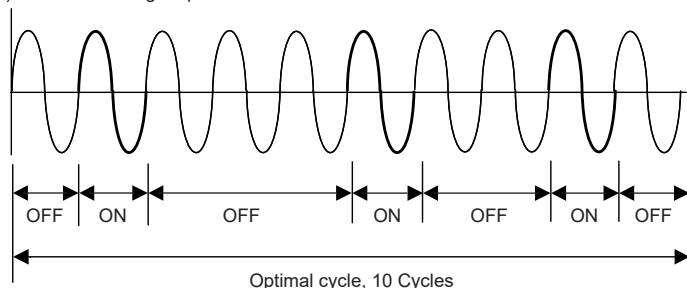

## ◎ ON/OFF control

This is control method that output is 100% at control input ON (approx. 18mA, min. 4.5VDC), and 0% at control input OFF (approx. 18mA, max. 4.5VDC).

※When using ON/OFF control method, output limit, SOFT START, SOFT UP/DOWN, input correction, and input slope correction functions are not settable.

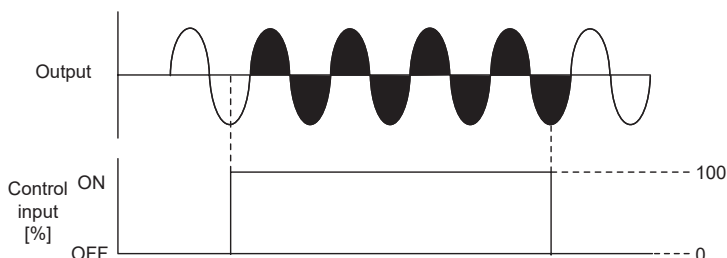

## ■ Functions

### ◎ Output limit (OUT ADJ)

This function will be  $[\text{Control input (\%)} \times \text{OUT ADJ (\%)} = \text{Output}]$  and it controls the power supplied into the load. Although control input is 100% (5V or 20mA), the output is the 50% which is proportioned with OUT ADJ.

※This function can not be used for ON/OFF control method.

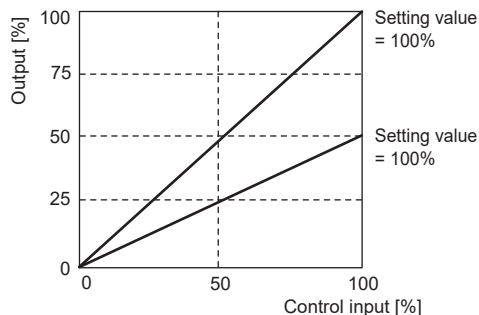

### ◎ SOFT START [5 - t ]

When the power is supplied, this function is able to protect the load when it controls load (molybdenum, white gold, infrared lamp) with inrush current or the width of rising temperature in big (SV is big). SOFT START set time (T) is the required time that output reaches to 100%, and it is differentiated by OUT ADJ set value.

※This function can not be used for ON/OFF control method.

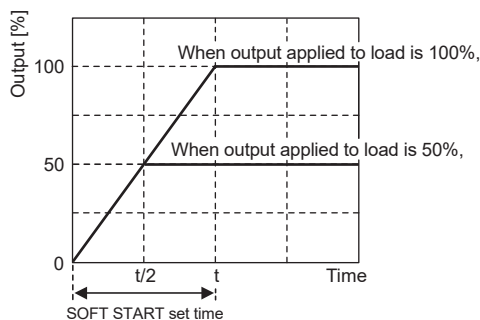

### ◎ Output high limit/low limit value [H - L / L - L ]

This function is to limit output range to protect load.

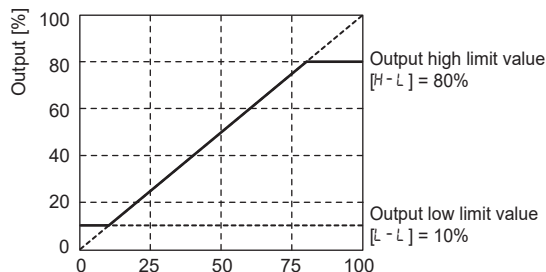

SENSORS

FIELD INSTRUMENTS

CONTROLLERS

MOTION DEVICES

SOFTWARE

(A) Temperature Controllers

(B) SSRs

(C) Power Controllers

(D) Counters

(E) Timers

(F) Digital Panel Meters

(G) Indicators

(H) Converters

(I) Digital Display Units

(J) Sensor Controllers

(K) Switching Mode Power Supplies

(L) Recorders

(M) HMIs

(N) Industrial PC

(O) Field Network Devices

# SPR1/SPR3 Series

## ◎ SOFT UP/DOWN [U-t / d-t]

Unlike SOFT START which operates only once at supplying power, this function protects load from the inrush current in the RUN mode. When reached to the target output value, operation stops.

※ This function can not be used for ON/OFF control method.

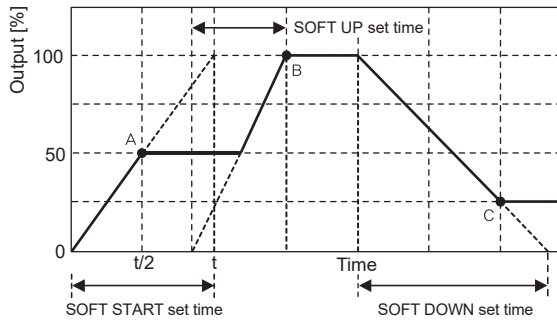

A: SOFT START function finished.  
B: SOFT UP function finished.  
C: SOFT DOWN function finished.

## ◎ Input correction [i nb]

It compensates the offset between actual input value and measured input value.

E.g.) When the input monitoring value is 5% at 4mA in DC4-20mA control input, setting  $i nb$  to -5 calibrates the input monitoring value to 0%.

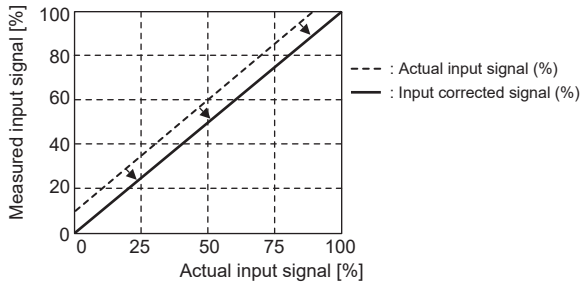

## ◎ Input slope correction [SPn]

It compensates the gain of the measured 100% input for actual 100% input value.

$$\text{Calibrated monitoring value} = \text{Monitoring value} + \frac{\text{Monitoring value} \times SP_n}{100 - SP_n}$$

E.g.) When the input monitoring value is 99% at 4mA in DC4-20mA control input, setting  $SP_n$  to 1 calibrates the input monitoring value to 100%.

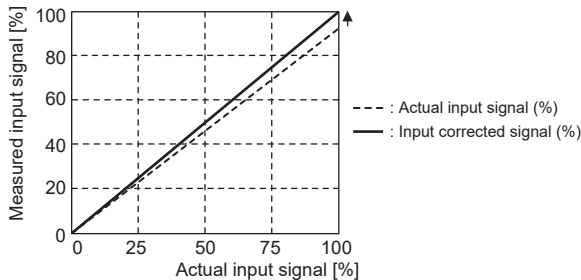

## ◎ RUN/STOP switching

RUN/STOP status of the power controller can be switched with the external RUN/STOP contact. In the RUN mode, the operation indicator on the front turns on.



## ◎ AUTO/MANUAL selection

Operation mode (auto control/manual control) of the power controller can be selected with the external AUTO/MAN contact.

In the manual control mode, the manual control indicator on the front turns on.



## ◎ RESET

In the event of system anomalies and alarms, RESET input restarts the power controller. (Parameters are not initialized.) Or, hold the  $\square$   $\square$  keys for 2 sec, to operates RESET.



## ◎ Alarm

Type	Display		Operation		Clear alarm
	Error	Priority	Alarm	Output	
SCR error alarm <sup>※1</sup>	5Cr	1			<ul style="list-style-type: none"> <li>• Re-supply the power</li> <li>• RESET</li> <li>• Switch to STOP mode</li> </ul>
Overcurrent alarm <sup>※1</sup>	o-C	2	• Error message flashes.	<ul style="list-style-type: none"> <li>• Output stops. (SCR OFF)</li> </ul>	
Heatsink overheat alarm	tEn	4	• Alarm indicator (ALM) flashes.		<ul style="list-style-type: none"> <li>• Alarm output turns ON</li> </ul>
Overvoltage alarm <sup>※1</sup>	o-u	5			
Fuse break alarm	FU5	3			
Frequency error alarm <sup>※2</sup>	F-rq	6			
Heater break alarm <sup>※1</sup>	H-b	7			<ul style="list-style-type: none"> <li>• Continues operation</li> </ul>

※1: This is only for feedback control models.

※2: This is only for normal control models of SPR1 Series.

※ When multiple alarms occur at the same time, the highest priority error message will be displayed based on priority.

### 1) SCR error alarm

Even though output is 0%, if the current of 10% or more of the rated load current flows for over 3 sec continuously, SCR error alarm occurs.

### 2) Overcurrent alarm

This function protects the load from overcurrent.

If the current flows over the overcurrent alarm setting value [oC] and setting delay time [oCt], overcurrent alarm occurs.

### 3) Heatsink overheat alarm

When the temperature of a heatsink is over 85°C, heatsink overheat alarm occurs.

### 4) Overvoltage alarm

This function protects the load from overvoltage.

If the current flows over the overvoltage alarm setting value [ou] and setting delay time [out], overvoltage alarm occurs.

### 5) Fuse break alarm

When braking fuse, not supplying load power, breaking load (single load), fuse brake alarm occurs.

### 6) Frequency error alarm

When the load power frequency is out of the specification, frequency error alarm occurs.

### 7) Heater break alarm

Comparing the full load resistance value and the current load resistance value, if the current load resistivity is maintained under the setting value [Hb] for over 3 sec continuously, heater break alarm occurs. This alarm operates when control output is over 10% and load current is over 10% of the rated current. Output does not stop and operates normally.

$$\text{Current load resistivity}(\%) = \frac{\text{Full load resistance value}}{\text{Current load resistance value}} \times 100$$

## ◎ Full load auto recognition [F-L]

This function recognizes the load resistance value automatically. Turning on this function operates the load with 100% of output for approx. 3 sec and sets the load resistance value in the product automatically.

※ This is only for feedback control models.

# Single-Phase/3-Phase, Slim Power Controller

## ◎ RMS display/control

SPR Series measures and displays RMS value for maintaining accuracy.

E.g.) At pure resistance load, when control input is 4-20mA, rating is 220V or 50A.

Control input	4mA	8mA	12mA	16mA	20mA	Unit
Amount of control input	0	25	50	75	100	%
Display voltage (normal control mode)	0	66	155	210	220	V
Display voltage (constant voltage feedback control mode)	0	55	110	165	220	V
Display current (constant current feedback control mode)	0	12	25	38	50	A

## ■ RS485 Communication Output

※Applicable for models with RS485 communication output through option output (SPR□-□□T□□).

Please refer to '■ Ordering Information'.

## ◎ Communication Specifications

Comm. protocol	Modbus RTU	Comm. speed	2400, 4800, 9600, 19200, 38400 bps
Connection method	RS485	Comm. response time	5 to 99ms (default: 20ms)
Application standard	Compliance with EIA RS485	Start bit	1-bit (fixed)
Max. connections	31 units (address: 1 to 99)	Data bit	8-bit (fixed)
Synchronization method	Asynchronous	Parity bit	None, Even, Odd
Comm. method	Two-wire half duplex	Stop bit	1-bit, 2-bit
Comm. distance	Max. 800m		

## ◎ Application of system organization

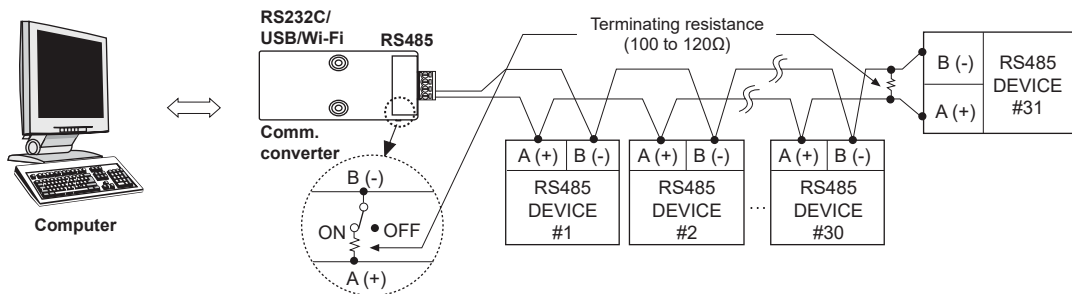

※It is recommended to use Autonics communication converter; SCM-WF48 (Wi-Fi to RS485-USB wireless communication converter, sold separately), SCM-US48I (USB to RS485 converter, sold separately), SCM-38I (RS232C to RS485 converter, sold separately). Please use twisted pair wire, which is suitable for RS485 communication, for SCM-WF48, SCM-US48I and SCM-38I.

## ■ Sold Separately

### ◎ Communication converter

- **SCM-WF48**  
(Wi-Fi to RS485-USB wireless communication converter)



- **SCM-US48I**  
(USB to RS485 converter)



- **SCM-38I**  
(RS232C to RS485 converter)



SENSORS

FIELD INSTRUMENTS

CONTROLLERS

MOTION DEVICES

SOFTWARE

(A) Temperature Controllers

(B) SSRs

(C) Power Controllers

(D) Counters

(E) Timers

(F) Digital Panel Meters

(G) Indicators

(H) Converters

(I) Digital Display Units

(J) Sensor Controllers

(K) Switching Mode Power Supplies

(L) Recorders

(M) HMIs

(N) Industrial PC

(O) Field Network Devices

# SPR1/SPR3 Series

## ■ Removing the Case

### ◎ SPR1 Series

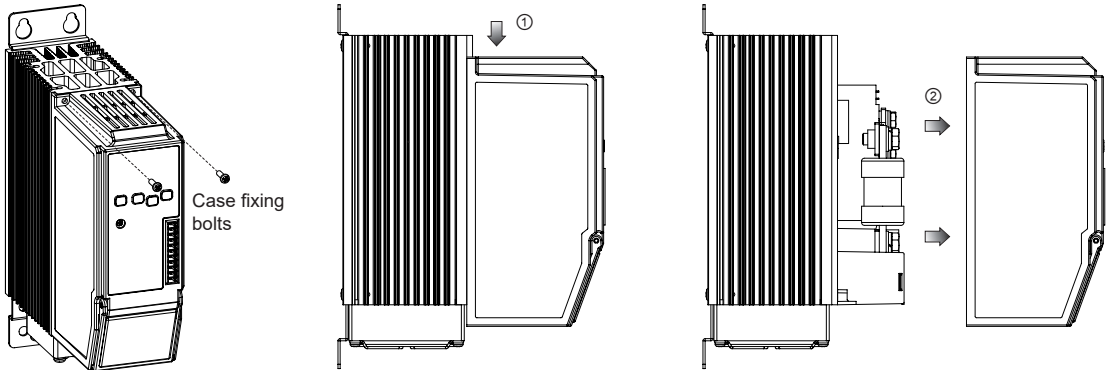

### ◎ SPR3 Series

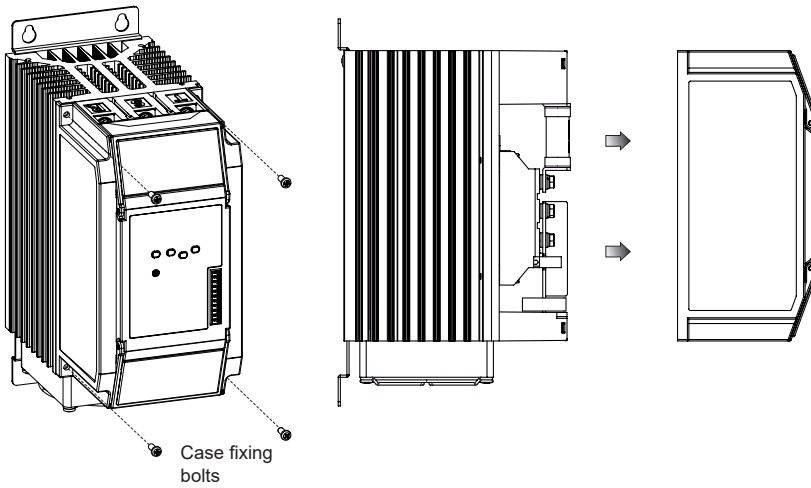

### ● Specification of case fixing bolts

Rated load current	Spec. of bolts
25A, 35A, 50A, 70A	M3
100A, 150A	M4

# Single-Phase/3-Phase, Slim Power Controller

## ■ Replacement of Fuse

### ◎ SPR1 Series

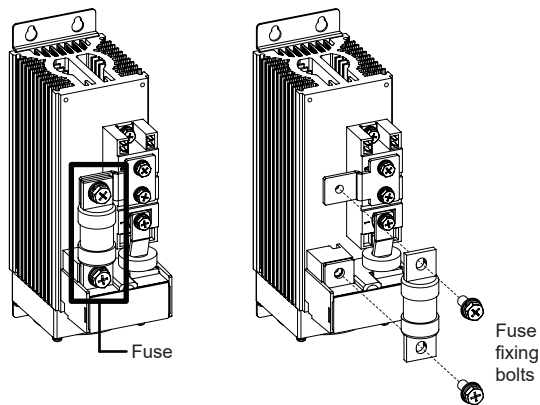

### ● Specification of fuse fixing bolts

Series	SPR1	SPR3
Rated load current		
25A	M6	M6
35A		
50A		
70A		
100A	M8	Top: M8
150A		Bottom: M6
		M8

### ● Recommended fuse specifications

For replacing the fuse, please use the recommended fuse which has the below specifications.

(manufacture: BUSSMANN, HINODE)

Series	SPR1	SPR3
Rated load current		
25A	50FE	50FE
35A	63ET	63ET
50A	80ET	80ET
70A	100FE	100FE
100A	FWH-150B	660GH-160 <sup>※1</sup>
150A	FWH-200B	660GH-200 <sup>※1</sup>

※1: Fuse manufacture: HINODE

※ The performance of the product is guaranteed only when using the fuse provided by us.

### ◎ SPR3 Series

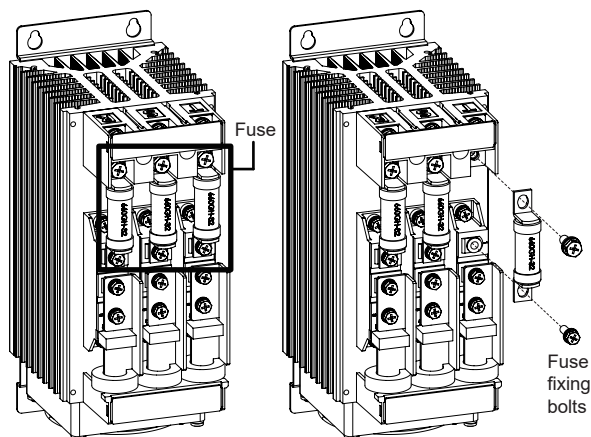

## ■ Proper Usage

### ⚠ Cautions during use

- Follow instructions in 'Cautions during Use'. Otherwise, it may cause unexpected accidents.
- Use the product, after 3 sec of supplying power.
- Before use, set the mode and function according to the specification.  
Especially, be cautious that the product does not operate when OUT ADJ. is set to 0%. Since changing the mode/parameter during operation may result in malfunction, set the mode and function after disconnecting load output.
- Re-supply the power to the unit after the unit is discharged completely.  
Failure to follow this instruction may result in malfunction.
- To ensure the reliability of the product, install the product on the panel or metal surface vertically to the ground.
- Install the unit in the well ventilated place.
- While supplying power to the load or right after turning off the power of the load, do not touch the body and heat sink.  
Failure to follow this instruction may result in a burn due to the high temperature.
- Install a power switch or circuit breaker in the easily accessible place for supplying or disconnecting the power.
- Do not wire to terminals which are not used.
- Since inter element can be damaged when using with coil load, inductive load, etc., the inrush current must be under the rated load current.
- Do not use near the equipment which generates strong magnetic force or high frequency noise.
- This unit may be used in the following environments.
  - Indoors (in the environment condition rated in 'Specifications')
  - Altitude max. 2,000m
  - Pollution degree 2
  - Installation category III

SENSORS

FIELD INSTRUMENTS

CONTROLLERS

MOTION DEVICES

SOFTWARE

(A) Temperature Controllers

(B) SSRs

(C) Power Controllers

(D) Counters

(E) Timers

(F) Digital Panel Meters

(G) Indicators

(H) Converters

(I) Digital Display Units

(J) Sensor Controllers

(K) Switching Mode Power Supplies

(L) Recorders

(M) HMIs

(N) Industrial PC

(O) Field Network Devices



## X-ON Electronics

Largest Supplier of Electrical and Electronic Components

*Click to view similar products for [Autonics](#) manufacturer:*

Other Similar products are found below :

[AS80-50DP3](#) [ASL-L04SP0-UY](#) [AT11DN](#) [AT11DN-2](#) [AT11DN-24-240](#) [AT11EN](#) [AT8N](#) [AT8N-1](#) [AT8N-2](#) [AT8N-24-240](#) [AT8PMN](#)  
[AT8PMN-2](#) [AT8PSN-2](#) [AT8SDN](#) [BA2M-DDT](#) [BA2M-DDT-P](#) [BC15-LDT-C](#) [BC15-LDT-C-P](#) [BEN10M-TFR](#) [BEN300-DFR](#) [BEN3M-PFR](#)  
[BEN5M-MFR](#) [BFX-D1-N](#) [BFX-D1-P](#) [BH1M-DDT](#) [BH300-DDT](#) [BJ100-DDT-C-P](#) [BJ100-DDT-P](#) [BJ10M-TDT-C-P](#) [BJ10M-TDT-P](#)  
[BJ15M-TDT-P](#) [BJ1M-DDT-C-P](#) [BJ1M-DDT-P](#) [BJ300-DDT-P](#) [BJ3M-PDT-C-P](#) [BJ3M-PDT-P](#) [BJ7M-TDT-P](#) [BJN100-NDT-P](#) [BJP100-BDT](#)  
[BJR100-DDT-C-P-F](#) [BJR10M-TDT-C-P-F](#) [BJR10M-TDT-P-F](#) [BJR15M-TDT-C-P-F](#) [BJR15M-TDT-P-F](#) [BJR1M-DDT-C-P-F](#) [BJR1M-DDT-](#)  
[P-F](#) [BJR3M-PDT-C-P-F](#) [BJR3M-PDT-P-F](#) [BL13-TDT-P](#) [BPS3M-TDT](#)