

AVERY DENNISON MARKETING SPECIFICATION

THE SUBJECT MATTER DISCLOSED HEREIN EMBODIES PROPRIETARY INFORMATION WHICH IS THE CONFIDENTIAL PROPERTY OF THE AVERY DENNISON CO. NONE OF WHICH SHALL BE COPIED, REPRODUCED, DISCLOSED TO OTHERS, PUBLISHED OR USED IN WHOLE OR IN PART FOR ANY PURPOSE OTHER THAN THAT FOR WHICH IT IS BEING MADE AVAILABLE WITHOUT THE EXPRESS ADVANCE WRITTEN PERMISSION OF A DULY AUTHORIZED AGENT OF THE COMPANY. THIS DOCUMENT IS THE PROPERTY OF THE AVERY DENNISON CO. AND IS TO BE RETURNED TO THE COMPANY ON DEMAND.

HISTORY

| REV. | DATE | DESCRIPTION |
|------|----------|-------------------------------------------------------------------------------|
| K | 01.24.14 | UPDATED TO THE NEW FORMAT; UPDATED DIM 5 FOR EASE OF INSPECTION |
| L | 09.25.14 | ADDED MIN INSTALL TEMP; UL LOGO AND 5000 PER CASE CHG LOOP TENSILE TO NEWTONS |
| M | 08.09.17 | UPDATED DIM 6 TOLERANCE |

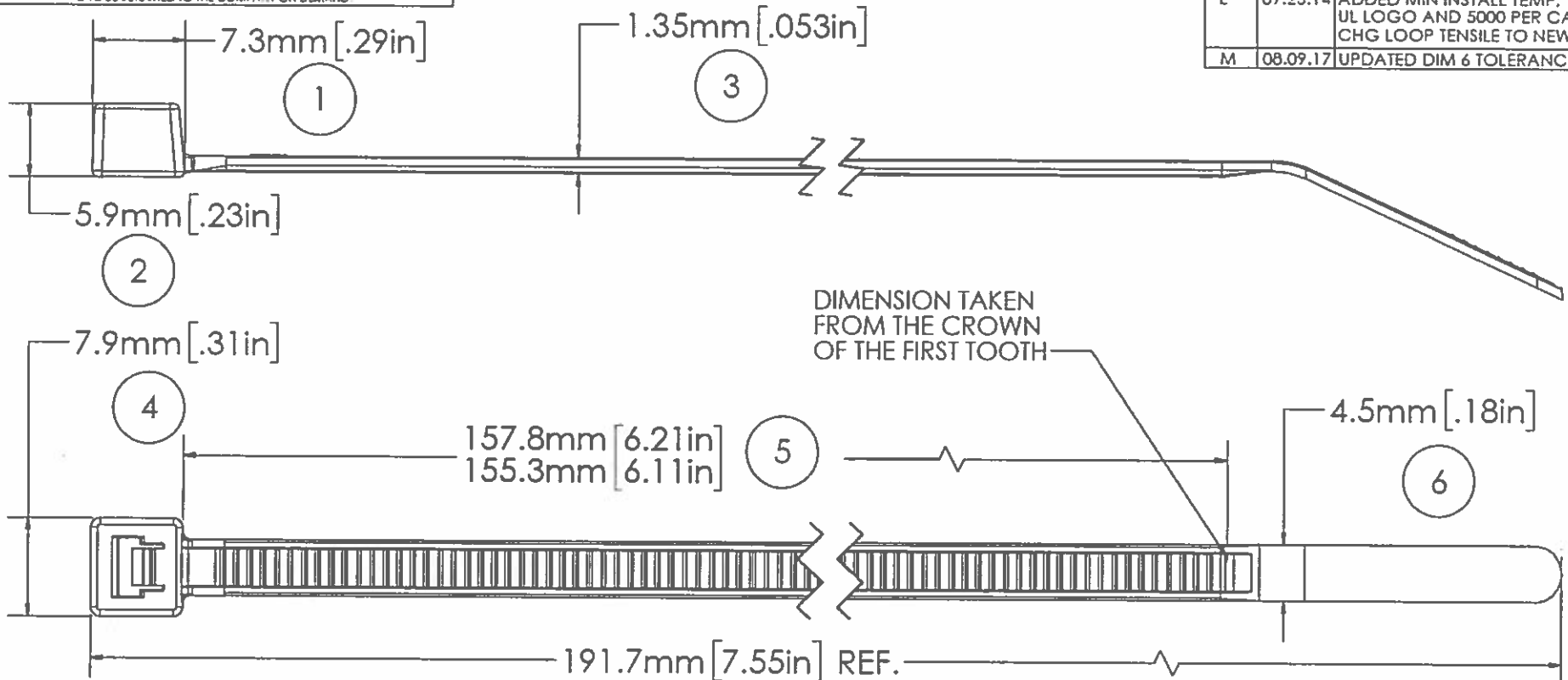

NOTE: THESE CABLE TIES ARE UV RESISTANT AND HAVE A FLAMMABILITY RATING OF V-2



LISTED
POSITIONING DEVICE
E57800
TYPE 21

| | |
|-------------------------|-------------------------------------------------------------------|
| LOOP TENSILE STRENGTH: | 50 LBF / 220N MIN. PER AS-2319D |
| OPERATING TEMP: | -40°F (-40°C) TO 176°F (80°C) |
| MIN. INSTALLATION TEMP: | 32°F (0°C) |
| WEIGHT: | 0.041 OZ./1.20 GRAMS |
| BUNDLE DIAMETER: | 1.59mm - 44.5mm |
| TOOL: | 12001 - HAND INSTALLATION TOOL 12500 - PNUM. INSTALLATION TOOL |
| TOOL TENSION SETTING: | 6 - 8 |
| PACKAGING: | 1000/BAG 5000/CASE (100 PACKS AVAILABLE) |

| | |
|------------|----------------------------------------------|
| APPROVALS: | ENG. APPR. <i>[Signature]</i> 08/09/17 |
| | Q.A. APPR. <i>Caitlin Chailancott</i> 5/9/17 |

| SPECIFIED TOLERANCES ARE: | |
|---------------------------|--------------|
| .XX ± .03 IN. | .X ± .7 MM |
| .XXX ± .01 IN. | .XX ± .25 MM |
| ANGULAR: ± 2° | |

| | |
|----------|---------------------------------|
| MATERIAL | NYLON 6/6, WEATHER RESISTANT |
| COLOR | BLACK |

| | | |
|-----------------------|---------------------------------------------------------------------------------------------------------------|---------------------|
| AVERY DENNISON | <small>FASTENER DIVISION FITCHBURG, MA 01420 U.S.A. TEL. 1-800-225-5913 FAX. 978-253-8157</small> | |
| | DESCRIPTION | 7.5" CABLE TIE, STD |
| STOCK NO. | 08388-0 | REV. M |

X-ON Electronics

Largest Supplier of Electrical and Electronic Components

Click to view similar products for [Cable Ties](#) category:

Click to view products by [Avery Dennison](#) manufacturer:

Other Similar products are found below :

[65034-C](#) [65037-C](#) [770-1751-10](#) [REL50L0C2](#) [20093-0](#) [SF600-120X](#) [SJ3518FR-1x50](#) [SJ3526N-Beige-2"x50yd](#) [SJ3526N BLACK 58" X 50YD](#) [SJ3571](#) [SJ-3571-1"x50yd-Black](#) [PLT2S-C4](#) [34-455-C](#) [3722](#) [561-B110120](#) [561-N3510](#) [TYZ528M](#) [34-463-C](#) [URT20S-M](#) [06226](#) [08350-0](#) [08600-0](#) [08376-0](#) [10325-0](#) [10362-0](#) [10606-0](#) [561-EZ250](#) [561-EZ625](#) [SJ3527N-Beige-2"x50yd](#) [SJ3527N-LOOP-BLACK-1](#) [SJ3572-2"x50yd-Black](#) [CF5625-000](#) [V03HK](#) [65004-C](#) [65005-C](#) [65007-C](#) [65036-C](#) [157-00039](#) [770-1708](#) [770-1753-10](#) [65035-C](#) [770-1752](#) [SPNY-041-9](#) [SF400-120X](#) [3719](#) [08582-0](#) [08386-0](#) [10431-0](#) [08359-0](#) [10620-0](#)