

AVERY DENNISON MARKETING SPECIFICATION

HISTORY

THE SUBJECT MATTER DISCLOSED HEREIN EMBODIES PROPRIETARY INFORMATION WHICH IS THE CONFIDENTIAL PROPERTY OF THE AVERY DENNISON CO. NONE OF WHICH SHALL BE COPIED, REPRODUCED, DISCLOSED TO OTHERS, PUBLISHED OR USED IN WHOLE OR IN PART, FOR ANY PURPOSE OTHER THAN THAT FOR WHICH IT IS BEING MADE AVAILABLE WITHOUT THE EXPRESS ADVANCE WRITTEN PERMISSION OF A DULY AUTHORIZED AGENT OF THE COMPANY. THIS DOCUMENT IS THE PROPERTY OF THE AVERY DENNISON CO. AND IS TO BE RETURNED TO THE COMPANY ON DEMAND.

| REV. | DATE | DESCRIPTION |
|------|----------|--|
| N | 07.15.09 | UPDATE MATERIAL DESCRIPTION |
| O | 09.24.14 | CHG DIM 1 TO BE TAKEN FROM BOTTOM OF THE HEAD, MADE MM THE PRIMARY UNITS |

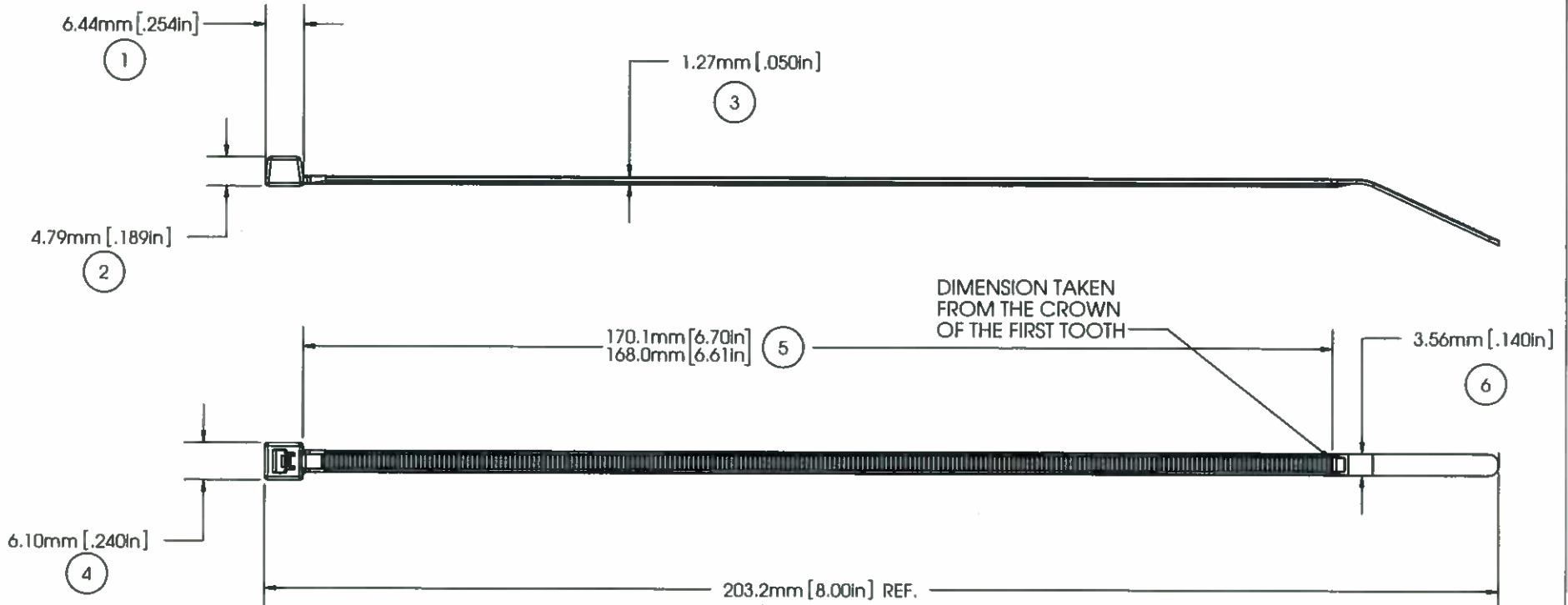

DIMENSION TAKEN FROM THE CROWN OF THE FIRST TOOTH



NOTE: THESE CABLE TIES ARE PLENUM RATED AND HAVE A FLAMMABILITY RATING OF V-2

| | |
|-------------------------|--|
| MILITARY STANDARD: | MS-3367-5-6 |
| LOOP TENSILE STRENGTH: | 40 LBF / 180N MIN. PER AS-23190 |
| OPERATING TEMP: | -40°F (-40°C) TO 185°F (85°C) |
| MIN. INSTALLATION TEMP: | 32°F (0°C) |
| WEIGHT: | 0.036 OZ. / 1.02 GRAMS |
| BUNDLE DIAMETER: | Ø 1.6MM TO Ø 54.0MM |
| TOOL: | 12001 - HAND INSTALLATION TOOL 12500 - PNUEM. INSTALLATION TOOL |
| TOOL TENSION SETTING: | 3-5 |
| PACKAGING: | 1000/BAG, 5000/CASE |

APPROVALS: ENG. APPR. *[Signature]* 9/24/14
Q.A. APPR. *[Signature]* 9/24/14

SPECIFIED TOLERANCES ARE:
.XX ± .03 IN. .X ± .7 MM
.XXX ± .010 IN. .XX ± .25 MM
ANGULAR: ± 2°

MATERIAL: NYLON 6/6
COLOR: BLUE

| | | | |
|--|-------------------------|-----------|------|
| AVERY DENNISON <small>FASTENER DIVISION FITCHBURG, MA 01420 U.S.A. TEL. 1-800-225-5913 FAX. 978-353-8157</small> | DESCRIPTION | STOCK NO. | REV. |
| | 8" CABLE TIE, INTERMED. | 08671-0 | O |

X-ON Electronics

Largest Supplier of Electrical and Electronic Components

Click to view similar products for [Cable Ties](#) category:

Click to view products by [Avery Dennison](#) manufacturer:

Other Similar products are found below :

[65037-C](#) [770-1751-10](#) [REL50L0C2](#) [20093-0](#) [SF600-120X](#) [SJ3518FR-1x50](#) [SJ3526N-Beige-2"x50yd](#) [SJ3526N BLACK 58" X 50YD](#) [SJ3571](#)
[SJ-3571-1"x50yd-Black](#) [PLT2S-C4](#) [34-455-C](#) [3722](#) [561-B110120](#) [561-N3510](#) [TYZ528M](#) [34-463-C](#) [URT20S-M](#) [06226](#) [08350-0](#) [08600-0](#)
[08376-0](#) [10037-0](#) [10325-0](#) [10362-0](#) [10606-0](#) [1122-4JW8](#) [561-EZ250](#) [561-EZ625](#) [SJ3527N-Beige-2"x50yd](#) [SJ3527N-LOOP-BLACK-1](#)
[SJ3572-2"x50yd-Black](#) [CF5625-000](#) [65004-C](#) [65005-C](#) [65007-C](#) [65036-C](#) [157-00039](#) [770-1708](#) [770-1753-10](#) [770-1752](#) [SPNY-041-9](#)
[SF400-120X](#) [3719](#) [08582-0](#) [08386-0](#) [10431-0](#) [08359-0](#) [10620-0](#) [10345-0](#)