

AVERY DENNISON MARKETING SPECIFICATION

| HISTORY | |
|---|---------|
| REV. | DATE |
| P | 2.25.15 |
| DESCRIPTION REDRAWN IN NEW FORMAT, ADDED UL INFORMATION AND LOGO | |

THE SUBJECT MATTER DISCLOSED HEREIN EMBODIES PROPRIETARY INFORMATION WHICH IS THE CONFIDENTIAL PROPERTY OF THE AVERY DENNISON CO. NONE OF WHICH SHALL BE COPIED, REPRODUCED, DISCLOSED TO OTHERS, PUBLISHED OR USED IN WHOLE OR IN PART, FOR ANY PURPOSE OTHER THAN THAT FOR WHICH IT IS BEING MADE AVAILABLE WITHOUT THE EXPRESS ADVANCE WRITTEN PERMISSION OF A DULY AUTHORIZED AGENT OF THE COMPANY. THIS DOCUMENT IS THE PROPERTY OF THE AVERY DENNISON CO. AND IS TO BE RETURNED TO THE COMPANY ON DEMAND.

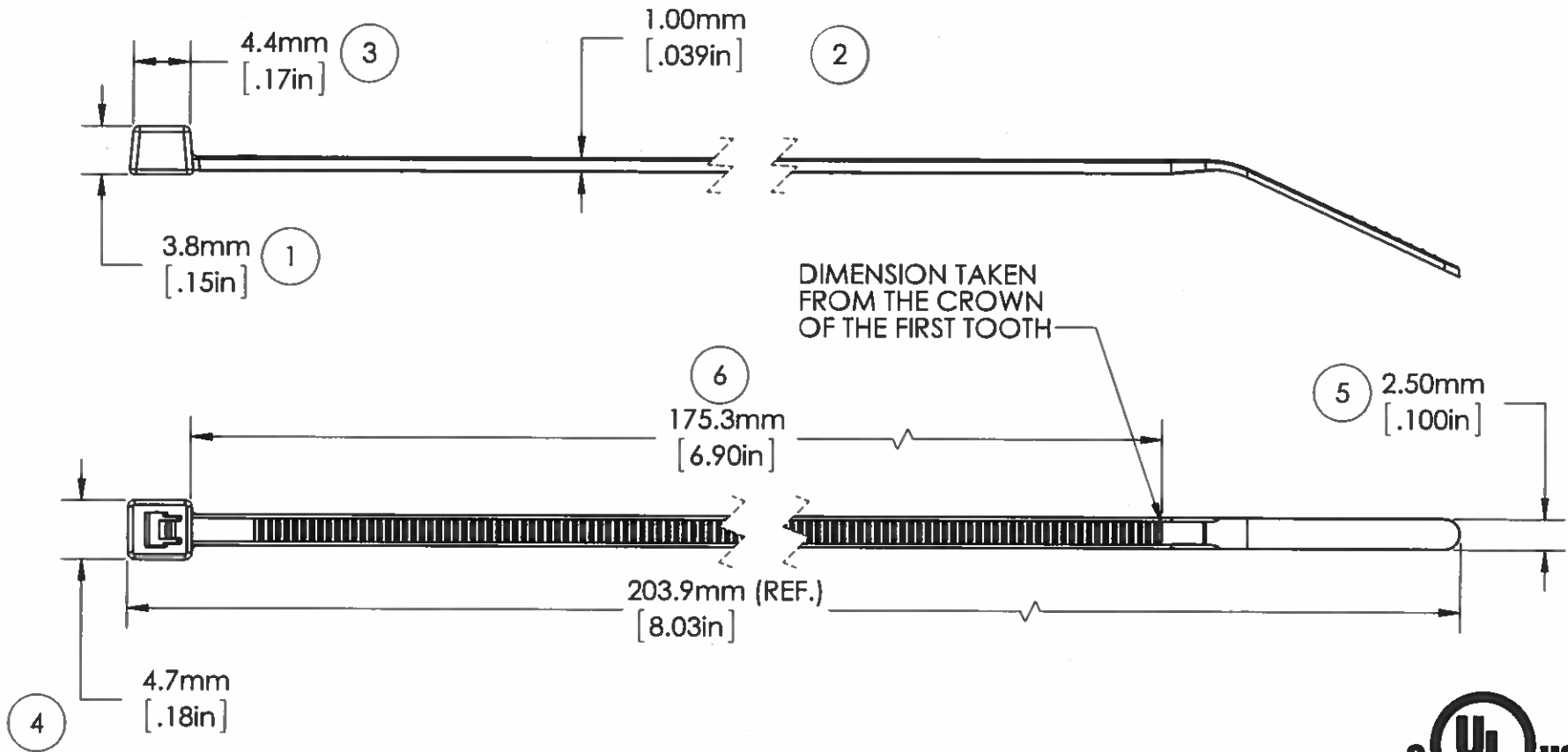

NOTE: THESE CABLE TIES ARE PLENUM RATED AND HAVE A FLAMMABILITY RATING OF V-2



| | |
|-------------------------|---|
| LOOP TENSILE STRENGTH: | 18 LBF/80 N MIN. PER AS-23190 |
| MILITARY STANDARD: | MS-3367-4-9 |
| OPERATING TEMP RANGE: | -4°F (-20°C) TO 185°F (85°C) |
| MIN. INSTALLATION TEMP: | 32°F (0°C) |
| WEIGHT: | 0.49g. / (0.01672 oz) |
| BUNDLE DIAMETER: | Ø 1.6mm TO Ø 54mm (0.06" - 2.13") |
| TOOL: | 12001-0 - HAND TOOL 12500-0 - PNEUMATIC TOOL |
| TOOL TENSION SETTING: | 1-3 |
| PACKAGING: | 1000/BAG, 5000/CASE |

| | |
|---------------------------|---------------------------------------|
| APPROVALS: | ENG. APPR. <i>[Signature]</i> 2/26/15 |
| | Q.A. APPR. <i>[Signature]</i> 2/25/15 |
| SPECIFIED TOLERANCES ARE: | |
| .XX ± .03 INCHES | .X ± .7 MM |
| .XXX ± .010 INCHES | .XX ± .25 MM |
| ANGULAR: ± 2° | |

| | | |
|--|--------------------------------|--|
| AVERY DENNISON <small>FASTENER DIVISION FITCHBURG, MA 01420 U.S.A. TEL. 1-800-225-5913 FAX. 978-353-8157</small> | DESCRIPTION | |
| | 8" CABLE TIE, SLIM-LINE | |
| STOCK NO. | REV. | |
| 10325-0 | P | |

X-ON Electronics

Largest Supplier of Electrical and Electronic Components

Click to view similar products for [Cable Ties](#) category:

Click to view products by [Avery Dennison](#) manufacturer:

Other Similar products are found below :

[65037-C](#) [770-1751-10](#) [REL50L0C2](#) [20093-0](#) [SF600-120X](#) [SJ3518FR-1x50](#) [SJ3526N-Beige-2"x50yd](#) [SJ3526N BLACK 58" X 50YD](#) [SJ3571](#)
[SJ-3571-1"x50yd-Black](#) [PLT2S-C4](#) [34-455-C](#) [3722](#) [561-B110120](#) [561-N3510](#) [TYZ528M](#) [34-463-C](#) [URT20S-M](#) [06226](#) [08350-0](#) [08600-0](#)
[08376-0](#) [10325-0](#) [10362-0](#) [10606-0](#) [561-EZ250](#) [561-EZ625](#) [SJ3527N-Beige-2"x50yd](#) [SJ3527N-LOOP-BLACK-1](#) [SJ3572-2"x50yd-Black](#)
[CF5625-000](#) [65004-C](#) [65005-C](#) [65007-C](#) [65036-C](#) [157-00039](#) [770-1708](#) [770-1753-10](#) [770-1752](#) [SPNY-041-9](#) [SF400-120X](#) [3719](#) [08582-0](#)
[08386-0](#) [10431-0](#) [08359-0](#) [10620-0](#) [10345-0](#) [08416-0](#) [08384-0](#)