

Standard 2.5mm Pitch Battery

9155-000

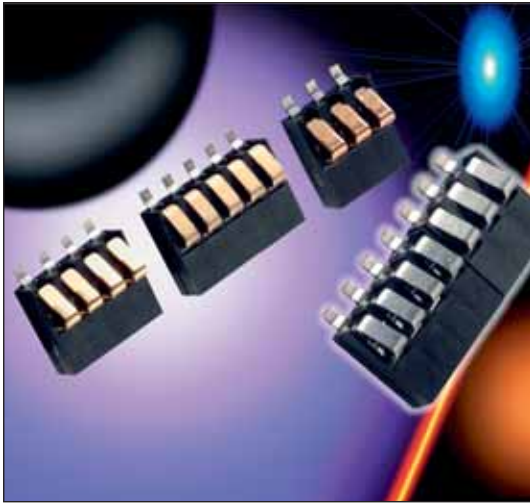

The standard battery connector is specifically designed for mobile equipment.

The connectors are available in 3, 4 and 5 contact positions all on a 2.50mm pitch. The insulator height provides a 3mm spacing, with various contact nose heights from 1.20mm to 2.60mm, to provide spacing options to the end user.

All contacts are stamped and are rated to 3A, with Gold plating. Parts are supplied in tape and reel for automatic pick and place. Optional retaining brackets are available to provide greater strength when connected to the PCB.

Whatever your requirements, the 9155 series Battery Connector can also be customized to suit your applications.

APPLICATIONS

- Mobile Phones
- PDA
- Medical
- PMR
- Industrial

FEATURES AND BENEFITS

- Suitable for 5000 mechanical cycles.
- Variety of contact heights offered to suit different mechanical designs.
- Connectors can be end to end stackable.
- RoHS Compliant available.

ELECTRICAL

- Current Rating: 3 Amp / Contact
- Voltage Rating: 125 VAC

ENVIRONMENTAL

- Operating Temperature: -40°C to +125°C

MECHANICAL

- Insulator Material: Glass-Filled Nylon 46; UL94 V-O
- Contact Material: Beryllium Copper
- Plating: Gold over Nickel
- Durability: 5000 Cycles



HOW TO ORDER

STANDARD

00	9155	00X	00	X	01	X
Prefix	Series	No of Ways	Standard Battery Connector	Contact Height	Bracket	Plating Option
00 = Standard 58 = Special		3 = 003 4 = 004 5 = 005	00 = Standard Force	1 = 1.20 (0.047) / 1.65 (0.064) 2 = 1.80 (0.071) / 2.10 (0.083) 3 = 2.30 (0.091) / 2.60 (0.102)	01 = With Bracket	6 = 0.4µm Selective Gold, Standard 8 = 0.8µm Selective Gold, Special Order

REDUCED NOSE

00	9155	00X	05	X	01	X
Prefix	Series	No of Ways	Standard Battery Connector	Contact Height	Bracket	Plating Option
00 = Standard 58 = Special		3 = 003 4 = 004 5 = 005	05 = Reduced Nose	1 = 1.20 (0.047) / 1.50 (0.059) 2 = 1.80 (0.071) / 2.10 (0.083) 3 = 2.30 (0.091) / 2.60 (0.102)	01 = With Bracket	6 = 0.4µm Selective Gold, Standard 8 = 0.8µm Selective Gold, Special Order

Standard 2.5mm Pitch Battery

9155-000



3 WAY BATTERY CONNECTOR

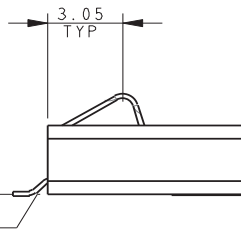
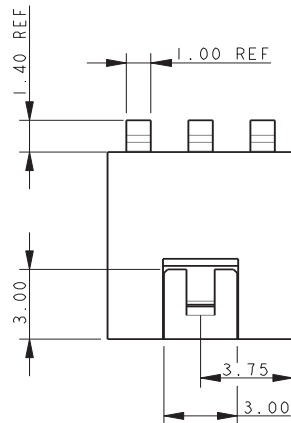
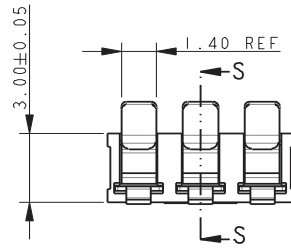
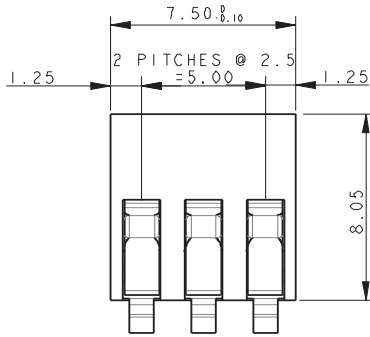

CONTACT TAILS TO BE WITHIN A 0.1 COPLANARITY RANGE WHEN INSULATOR IS SITTING ON DATUM FACE.

NOTES:

1. FOR MORE INFORMATION REFER TO PRODUCT SPEC 201-01-050.
2. GENERAL TOLERANCE ± 0.20 UNLESS OTHERWISE STATED.
3. FOR MATING PAD DETAILS REFER TO PAGE 5.
4. INSULATOR MATERIAL: 30% GLASS FILLED NYLON 46, UL94 V-O. COLOR BLACK.
5. CONTACT MATERIAL: BERYLLIUM COPPER.
6. CONTACT PLATING: SELECTIVE GOLD OVER NICKEL. PURE TIN ON TAILS.
7. BRACKET MATERIAL: PHOSPHOR BRONZE.
8. BRACKET PLATING: PURE TIN OVER NICKEL.

MATING CONDITIONS

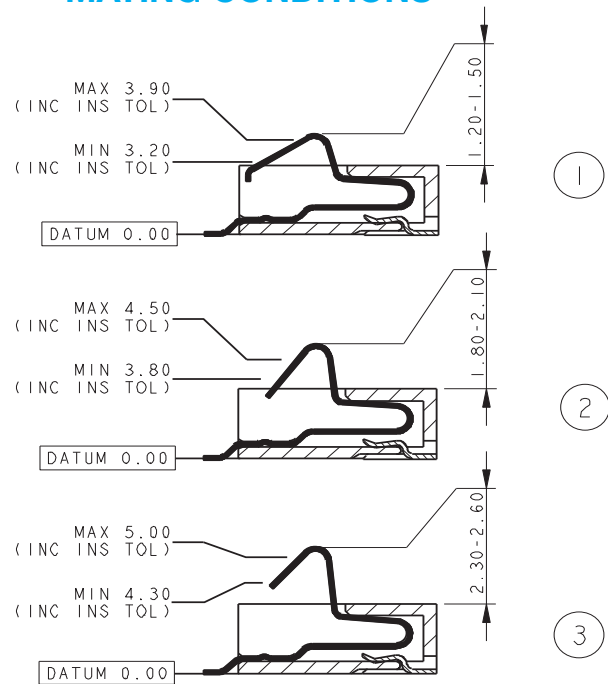

PCB BOARD LAYOUT

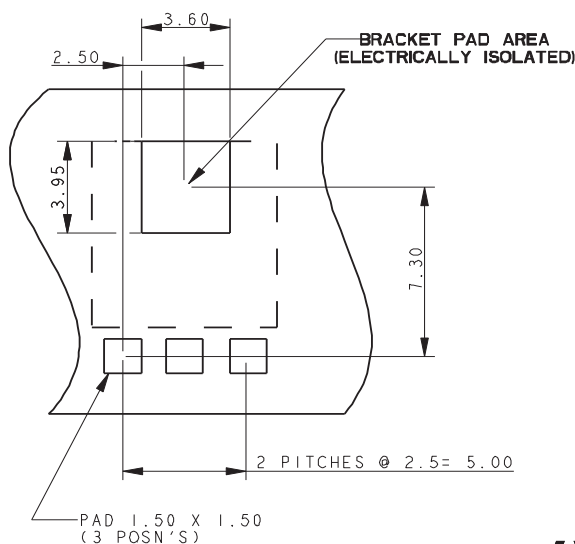

PACKING DETAILS

REEL QTY	1000
LEADER	500MM
TRAILER	500MM
REEL / BOX	5

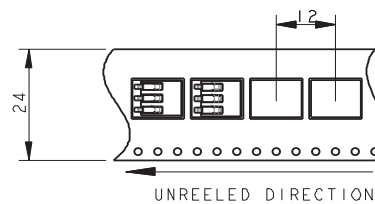
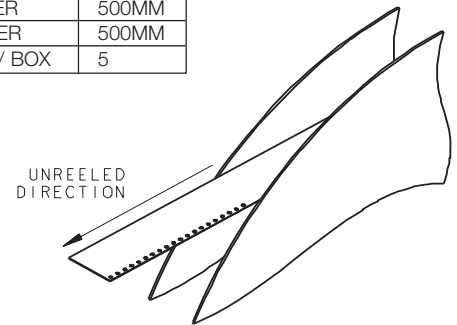

Standard 2.5mm Pitch Battery

9155-000

4 WAY BATTERY CONNECTOR

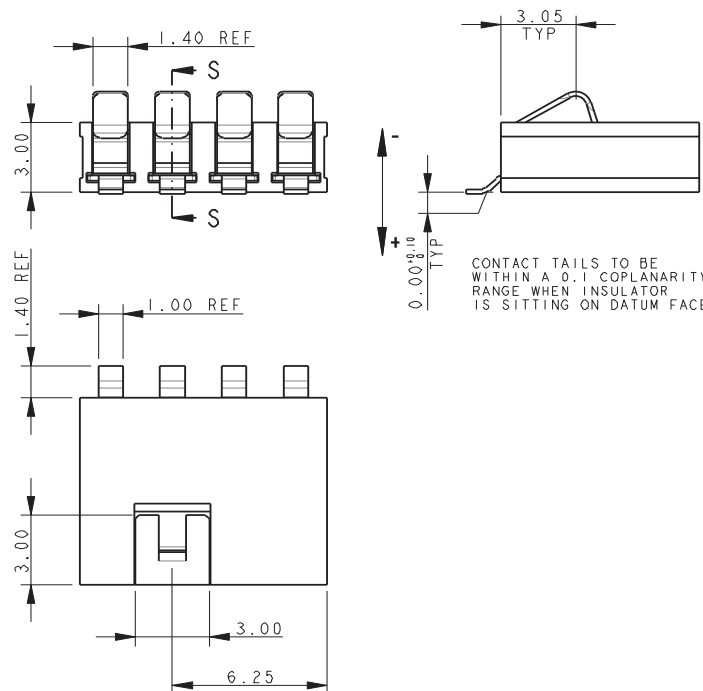
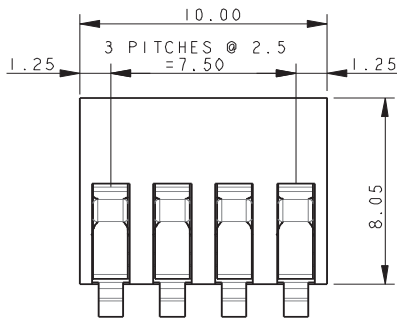

NOTES:

1. FOR MORE INFORMATION REFER TO PRODUCT SPEC 201-01-050.
2. GENERAL TOLERANCE ± 0.20 UNLESS OTHERWISE STATED.
3. FOR MATING PAD DETAILS REFER TO PAGE 5.
4. INSULATOR MATERIAL: 30% GLASS FILLED NYLON 46, UL94 V-O. COLOR BLACK.
5. CONTACT MATERIAL: BERYLLIUM COPPER.
6. CONTACT PLATING: SELECTIVE GOLD OVER NICKEL. PURE TIN ON TAILS.
7. BRACKET MATERIAL: PHOSPHOR BRONZE.
8. BRACKET PLATING: PURE TIN OVER NICKEL.

MATING CONDITIONS

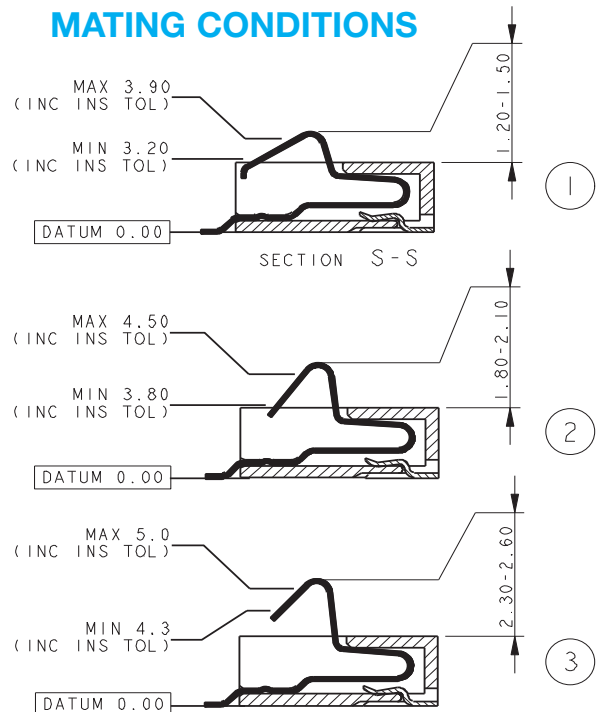

CONTACT TAILS TO BE WITHIN A 0.1 COPLANARITY RANGE WHEN INSULATOR IS SITTING ON DATUM FACE.

PCB BOARD LAYOUT

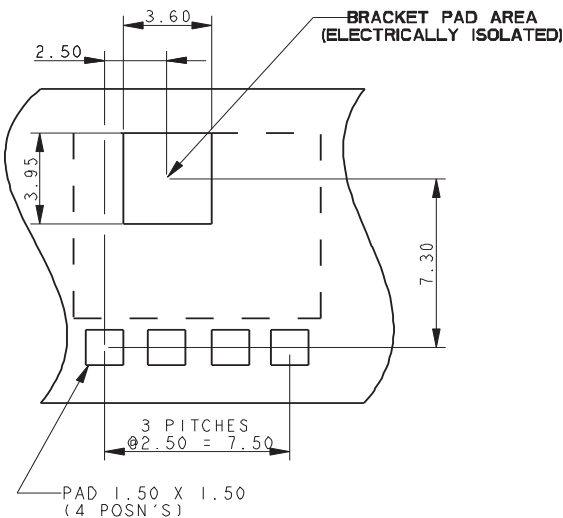

PACKING DETAILS

REEL QTY	1000
LEADER	500MM
TRAILER	500MM
REEL / BOX	5

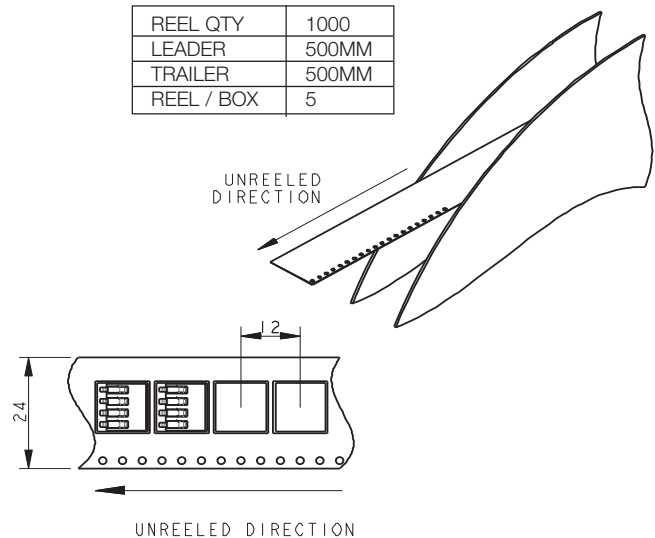

Standard 2.5mm Pitch Battery

9155-000

5 WAY BATTERY CONNECTOR

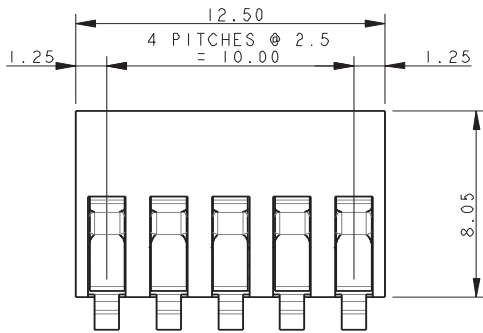

NOTES:

1. FOR MORE INFORMATION REFER TO PRODUCT SPEC 201-01-050.
2. GENERAL TOLERANCE ± 0.20 UNLESS OTHERWISE STATED.
3. FOR MATING PAD DETAILS REFER TO PAGE 5.
4. INSULATOR MATERIAL: 30% GLASS FILLED NYLON 46, UL94 V-O. COLOR BLACK.
5. CONTACT MATERIAL: BERYLLIUM COPPER.
6. CONTACT PLATING: SELECTIVE GOLD OVER NICKEL. PURE TIN ON TAILS.
7. BRACKET MATERIAL: PHOSPHOR BRONZE.
8. BRACKET PLATING: PURE TIN OVER NICKEL.

MATING CONDITIONS

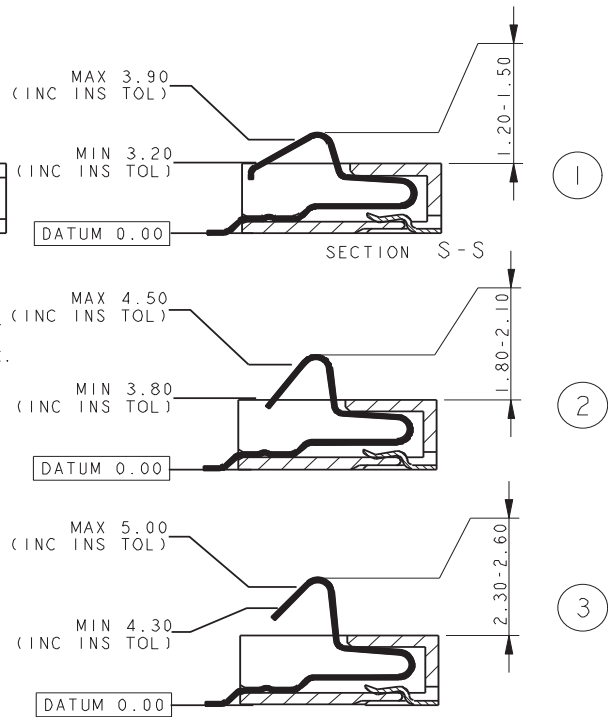
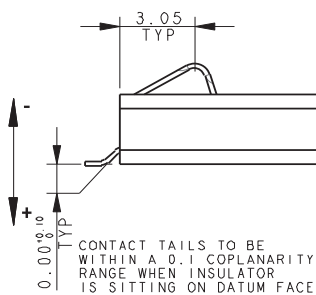
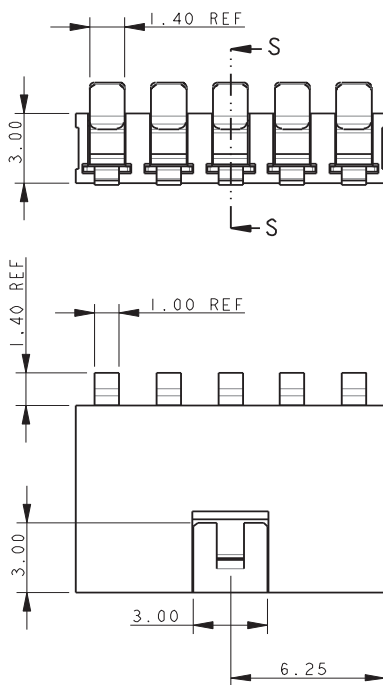

PCB BOARD LAYOUT

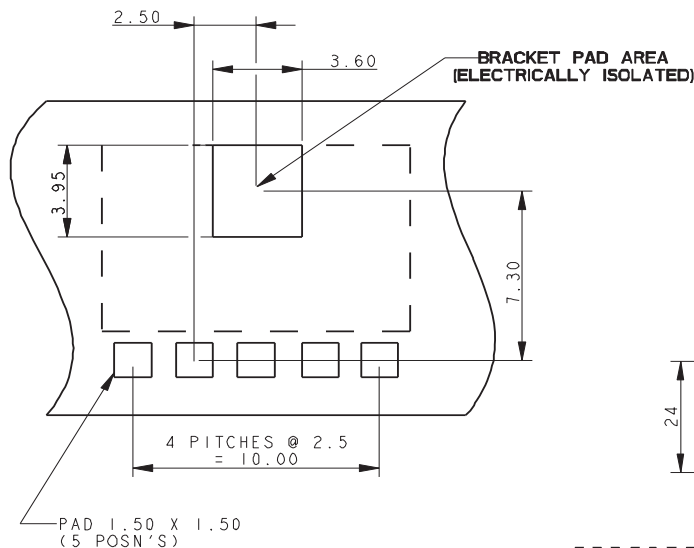

PACKING DETAILS

REEL QTY	1000
LEADER	500MM
TRAILER	500MM
REEL / BOX	5

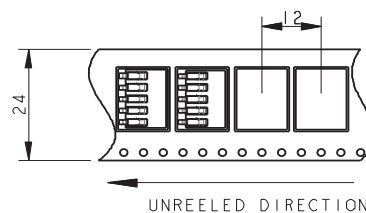
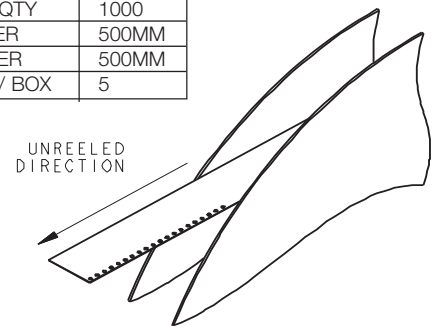

STANDARD BATTERY – MATING PADS

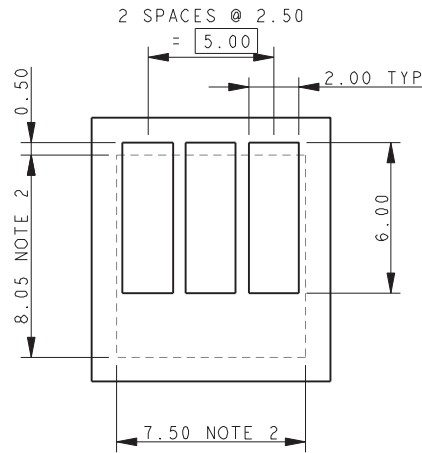

3 WAY MATING PADS

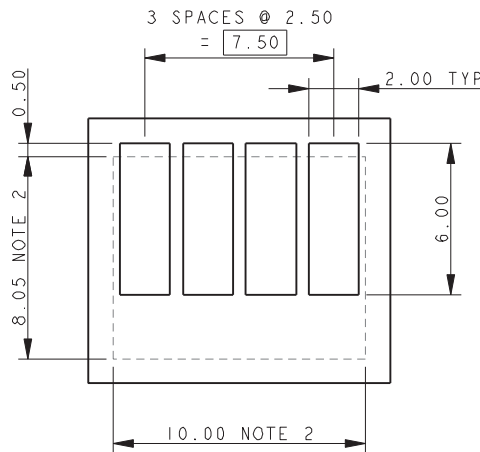

4 WAY MATING PADS

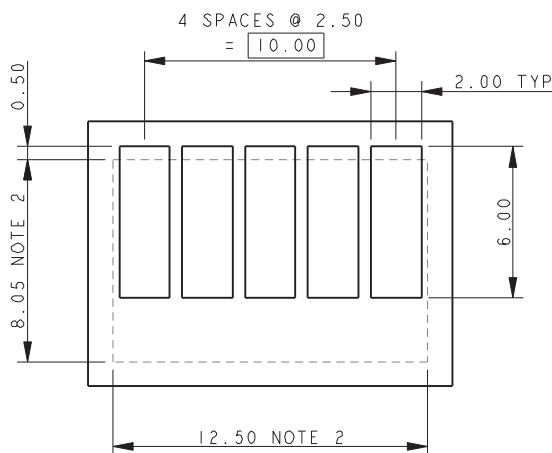

5 WAY MATING PADS

NOTES:

1. SUGGESTED MATING PADS FOR STANDARD BATTERY CONNECTORS.
2. OUTLINE OF CONNECTOR.
3. PREFERRED PLATING ON PADS GOLD OVER NICKEL.
4. PAD LENGTH MAY REQUIRE ADJUSTMENT OF MATCH THE CUSTOMERS ASSEMBLY.
5. REFERENCE DIMENSIONS.

Standard 2.5mm Pitch Battery

9155-000

3 WAY BATTERY CONNECTOR REDUCED NOSE

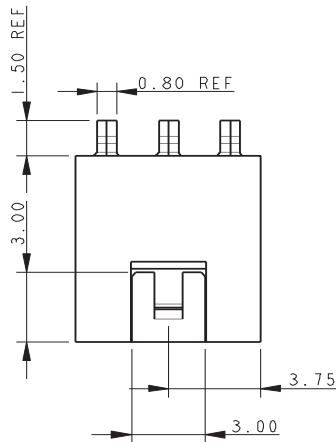
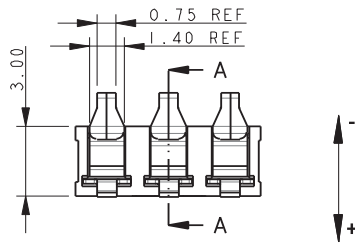
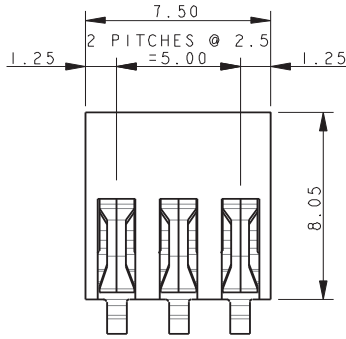

NOTES:

1. FOR MORE INFORMATION REFER TO PRODUCT SPEC 201-01-050.
2. GENERAL TOLERANCE ± 0.20 UNLESS OTHERWISE STATED.
3. FOR MATING PAD DETAILS REFER TO PAGE 9.
4. INSULATOR MATERIAL: 30% GLASS FILLED NYLON 46, UL94 V-O. COLOR BLACK.
5. CONTACT MATERIAL: BERYLLIUM COPPER.
6. CONTACT PLATING: SELECTIVE GOLD OVER NICKEL. PURE TIN ON TAILS.
7. BRACKET MATERIAL: PHOSPHOR BRONZE.
8. BRACKET PLATING: PURE TIN OVER NICKEL.

MATING CONDITIONS

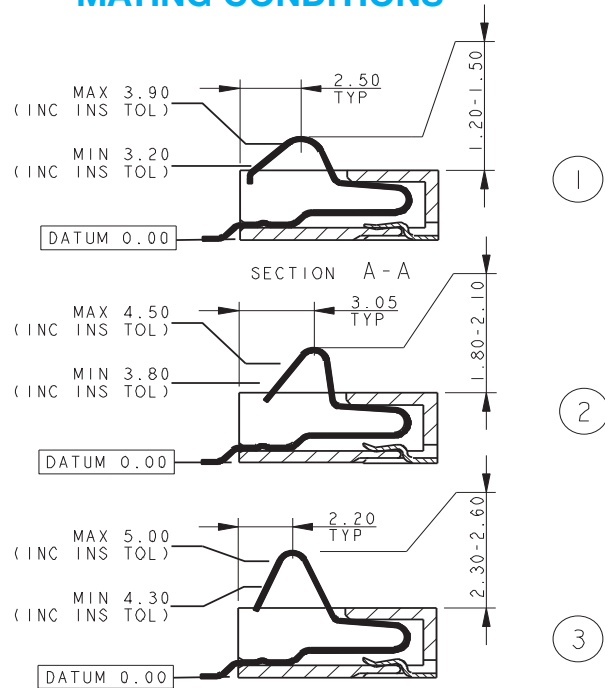
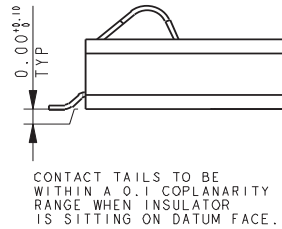

PCB BOARD LAYOUT

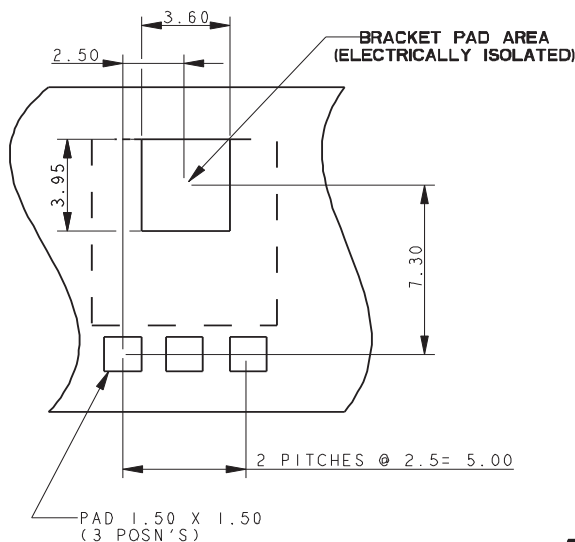

PACKING DETAILS

REEL QTY	1000
LEADER	500MM
TRAILER	500MM
REEL / BOX	5

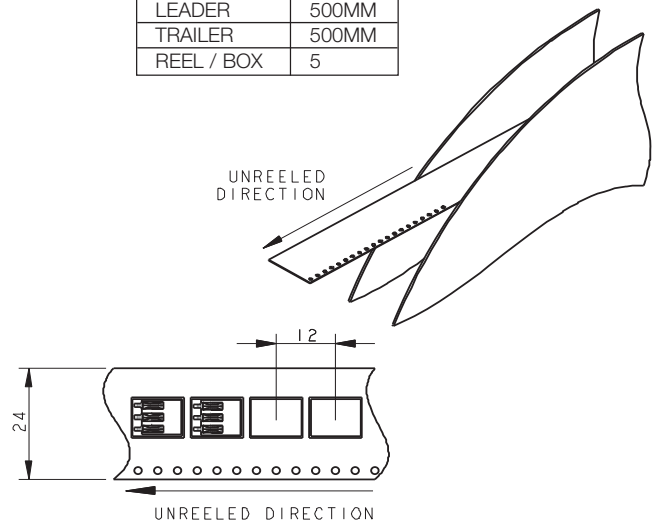

Standard 2.5mm Pitch Battery

9155-000

4 WAY BATTERY CONNECTOR REDUCED NOSE

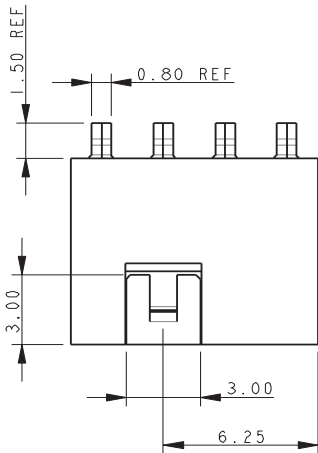
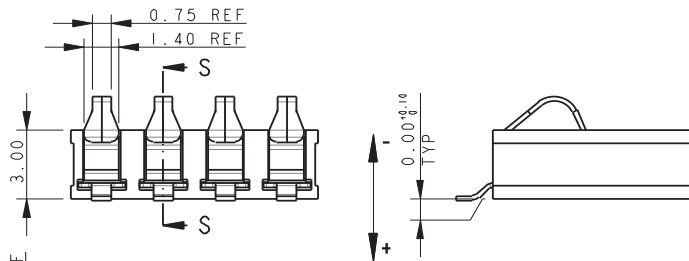
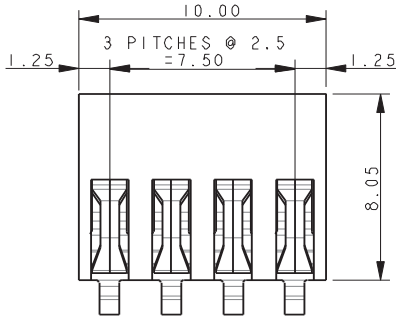

NOTES:

1. FOR MORE INFORMATION REFER TO PRODUCT SPEC 201-01-050.
2. GENERAL TOLERANCE ± 0.20 UNLESS OTHERWISE STATED.
3. FOR MATING PAD DETAILS REFER TO PAGE 9.
4. INSULATOR MATERIAL: 30% GLASS FILLED NYLON 46, UL94 V-O. COLOR BLACK.
5. CONTACT MATERIAL: BERYLLIUM COPPER.
6. CONTACT PLATING: SELECTIVE GOLD OVER NICKEL. PURE TIN ON TAILS.
7. BRACKET MATERIAL: PHOSPHOR BRONZE.
8. BRACKET PLATING: PURE TIN OVER NICKEL.

MATING CONDITIONS

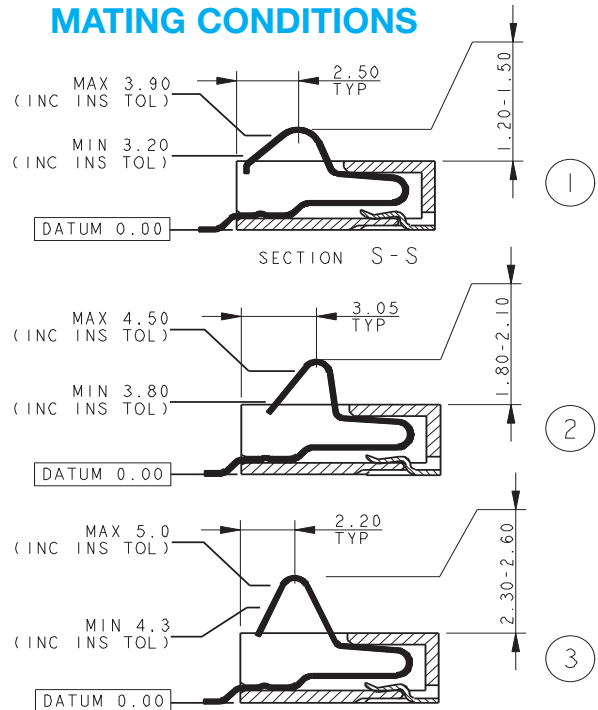

CONTACT TAILS TO BE WITHIN A 0.1 COPLANARITY RANGE WHEN INSULATOR IS SITTING ON DATUM FACE.

PCB BOARD LAYOUT

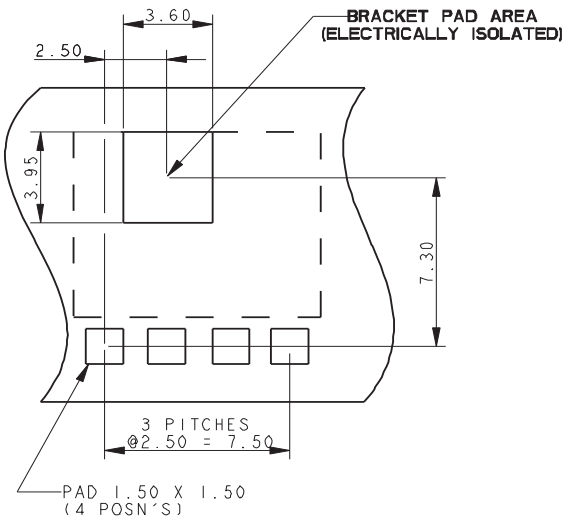

PACKING DETAILS

REEL QTY	1000
LEADER	500MM
TRAILER	500MM
REEL / BOX	5

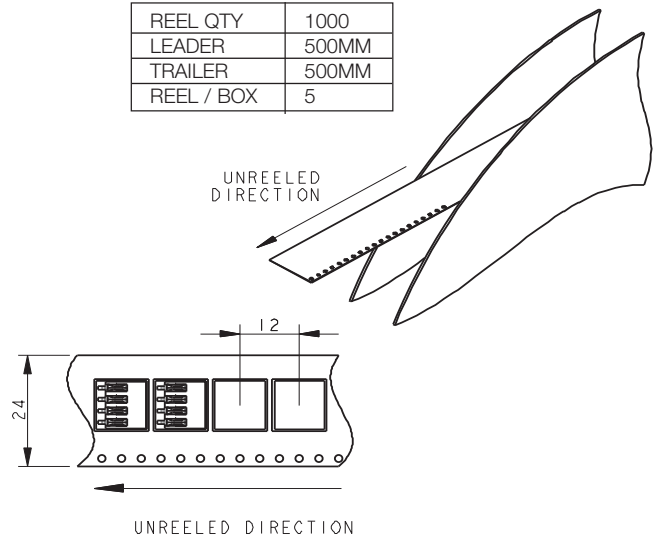

Standard 2.5mm Pitch Battery

9155-000

5 WAY BATTERY CONNECTOR REDUCED NOSE

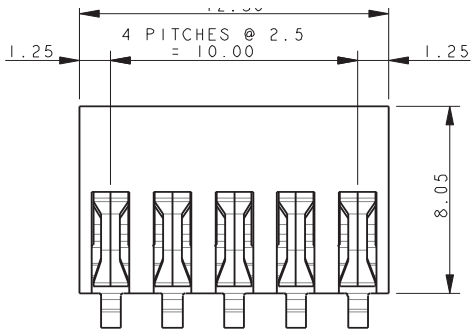

NOTES:

1. FOR MORE INFORMATION REFER TO PRODUCT SPEC 201-01-050.
2. GENERAL TOLERANCE ± 0.20 UNLESS OTHERWISE STATED.
3. FOR MATING PAD DETAILS REFER TO PAGE 9.
4. INSULATOR MATERIAL: 30% GLASS FILLED NYLON 46, UL94 V-O. COLOR BLACK.
5. CONTACT MATERIAL: BERYLLIUM COPPER.
6. CONTACT PLATING: SELECTIVE GOLD OVER NICKEL. PURE TIN ON TAILS.
7. BRACKET MATERIAL: PHOSPHOR BRONZE.
8. BRACKET PLATING: PURE TIN OVER NICKEL.

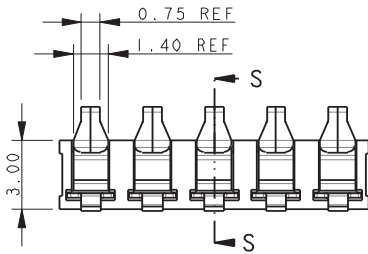

CONTACT TAILS TO BE WITHIN A 0.1° COPLANARITY RANGE WHEN INSULATOR IS SITTING ON DATUM FACE.

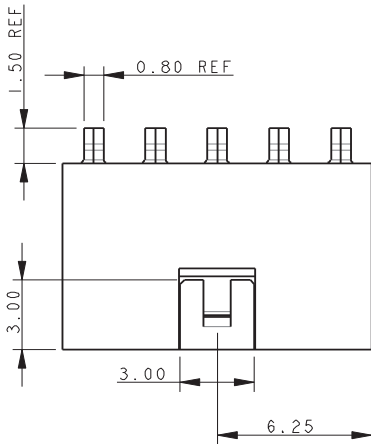

MATING CONDITIONS

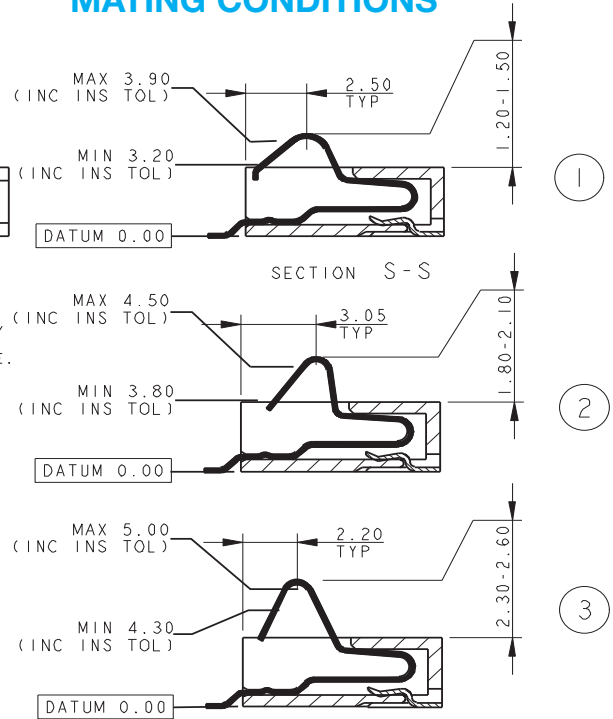

PCB BOARD LAYOUT

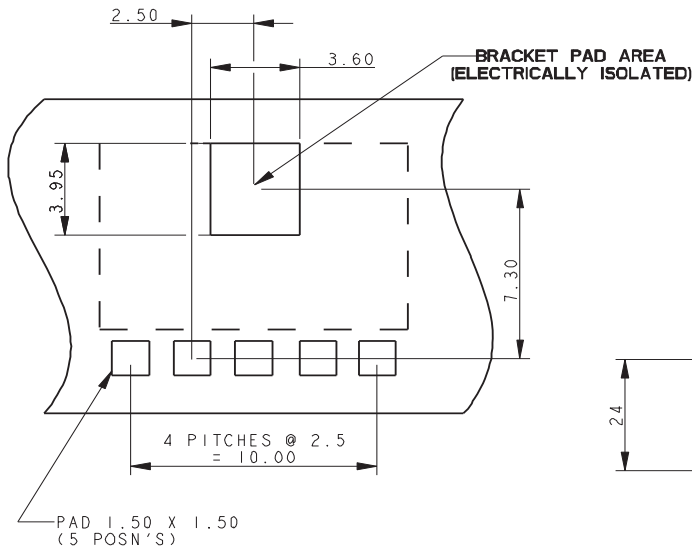

PACKING DETAILS

REEL QTY	1000
LEADER	500MM
TRAILER	500MM
REEL / BOX	5

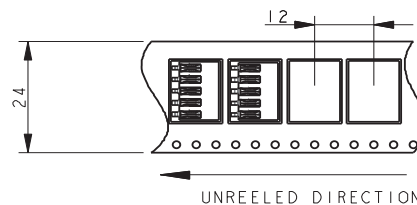
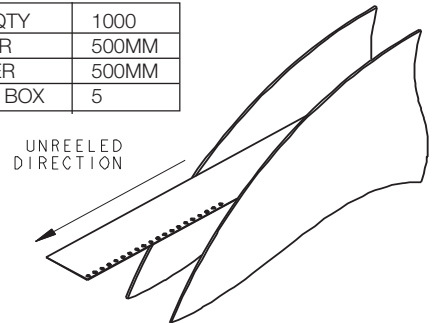

STANDARD BATTERY – MATING PADS

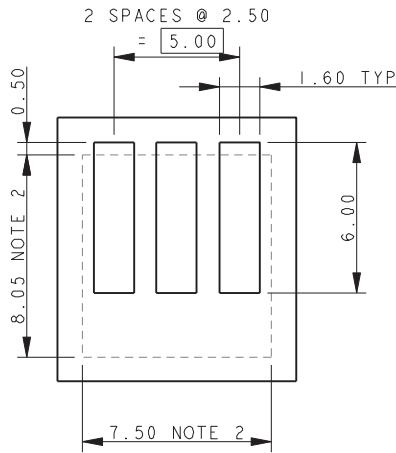

3 WAY MATING PADS

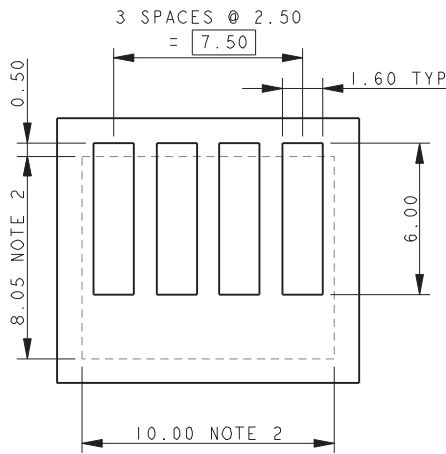

4 WAY MATING PADS

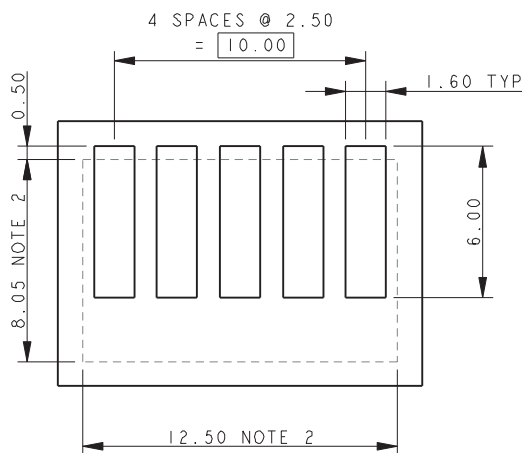

5 WAY MATING PADS

NOTES:

1. SUGGESTED MATING PADS FOR STANDARD BATTERY CONNECTORS.
2. OUTLINE OF CONNECTOR.
3. PREFERRED PLATING ON PADS GOLD OVER NICKEL.
4. PAD LENGTH MAY REQUIRE ADJUSTMENT OF MATCH THE CUSTOMERS ASSEMBLY.
5. REFERENCE DIMENSIONS.

X-ON Electronics

Largest Supplier of Electrical and Electronic Components

Click to view similar products for [Battery Contacts](#) category:

Click to view products by [AVX](#) manufacturer:

Other Similar products are found below :

[H-843](#) [3.5MM-UNIVERSAL-CONTACT](#) [4030](#) [120220-0310](#) [120220-0311](#) [101267-209](#) [009155003001013](#) [98285-1000](#) [0475070010](#) [72](#)
[1189](#) [120](#) [120220-0202](#) [120220-0206](#) [1241](#) [113](#) [118](#) [2199206-1](#) [2472](#) [118TR](#) [009155003101008](#) [120220-0204](#) [120TR](#) [2983](#) [117](#) [122TR](#)
[111](#) [120220-0312](#) [5330TR](#) [009155003741006](#) [122](#) [5331TR](#) [009155002741006](#) [498TR](#) [009155004741006](#) [556TR](#) [009155005741006](#)
[009155006741006](#) [70ADJ-2-FL1G](#) [70ADJ-3-FL1G](#) [1902937-1](#) [497](#) [5203](#) [5219](#) [5225](#) [550](#) [553](#) [555](#) [556](#) [202-02970-00518](#)