

## Low Noise Amplifier for Global Navigation Satellite Systems (GNSS)

### Features

- Reduce RF environment Interference with patented Smart-Linearity-Technology (SLT)
- Ultra low current=1.2 mA
- Low noise figure(NF)=0.7 dB
- High power gain=18.2 dB
- High input 1dB-compression point=-7 dBm
- GPS L1 requires only one input matching inductor
- RF output internally matched to 50 ohm for GPS L1
- Supply voltage: 1.5 V to 3.1 V
- Operating frequencies: 1550~1615 MHz, 1164~1215 MHz
- DFN 1.1 mmX0.7 mmX0.37 mm-6L package
- ±2 kV HBM ESD protection (including RFIN and RFOUT pin)

### Applications

- Smart phones, feature phones
- Tablet PCs
- Personal Navigation Devices
- Digital Still Cameras, Digital Video Cameras
- RF Front End modules
- Complete GPS chipset modules
- Theft protection(laptop, ATM)

### General Description

The AW15085 is a Low Noise Amplifier designed for Global Navigation Satellite Systems (GNSS) as GPS, Beidou, GLONASS, Galileo and Compass. With on-chip DC blocking capacitors at RFIN and RFOUT, the AW15085 can be close to the antenna. The AW15085 requires only one external input matching inductor for GPS L1, which can reduce assembly complexity and the PCB area, enabling a cost-effective solution.

The AW15085 with patented Smart Linearity Technology (SLT) achieves low noise figure, high linearity, high gain, over a wide range of supply voltages from 1.5 V up to 3.1 V. All these features make AW15085 an excellent choice for GNSS LNA as it improves sensitivity with low noise figure and high gain, provides better immunity against out-of-band jammer signals with high linearity, reduces filtering requirement of preceding stage and hence reduces the overall cost of the GNSS receiver.

The AW15085 is available in a small lead-free, RoHS-Compliant, DFN 1.1 mm X 0.7 mm X 0.37 mm-6L package.

### Typical Application Circuit

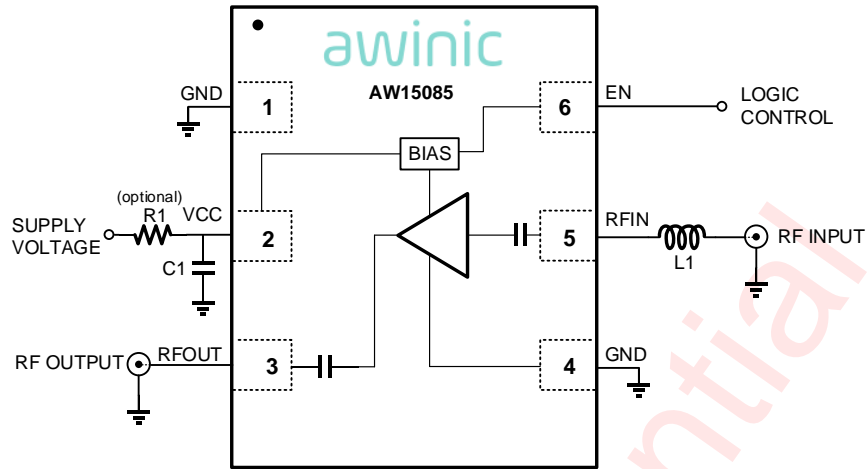

C1, R1, L1 Closed to LNA

### Typical Application Circuit of AW15085 for GNSS L1

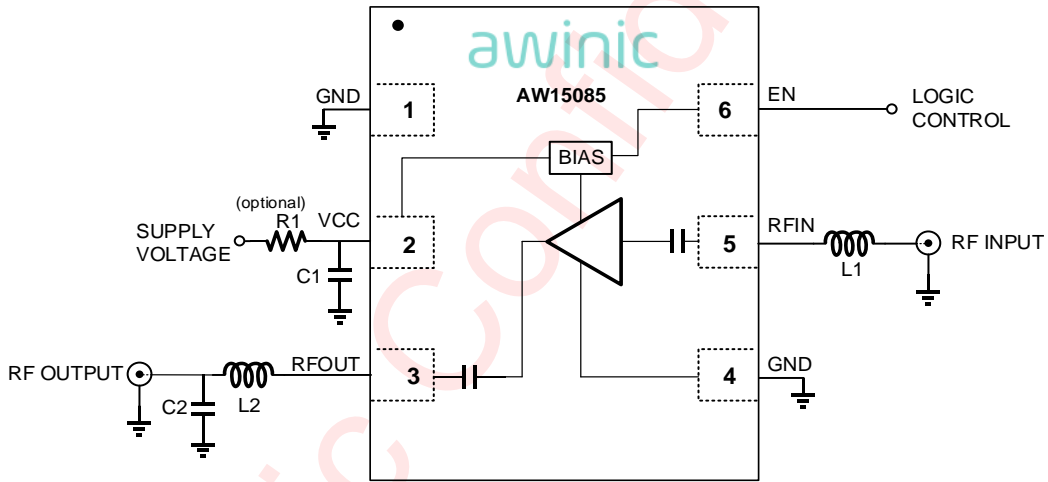

C1, R1, L1, C2, L2 Closed to LNA

### Typical Application Circuit of AW15085 for GNSS L5

All trademarks are the property of their respective owner

## Recommended Components List

Table1 and Table2 list the recommended components types and values.

Table1: list of components for GNSS L1

Component	Part Number	Inductance	Q(min)	Q Test Frequency	Supplier	Size
L1	LQW15A	12nH	30	250MHz	Murata	0402
L1	SDWL1005C	12nH	28	250MHz	Sunlord	0402
Component	Part Number	Capacitance	Rated Voltage	Supplier	Size	
C1	GRM155	1nF	50V	Murata	0402	

Table2: list of components for GNSS L5

Component	Part Number	Inductance	Q(min)	Q Test Frequency	Supplier	Size
L1	LQW15A	20nH	30	250MHz	Murata	0402
L2	LQW15A	12nH	30	250MHz	Murata	0402
Component	Part Number	Capacitance	Rated Voltage	Supplier	Size	
C1	GRM155	1nF	50V	Murata	0402	
C2	GRM155	3.3pF	50V	Murata	0402	

## Pin Configuration And Top Mark

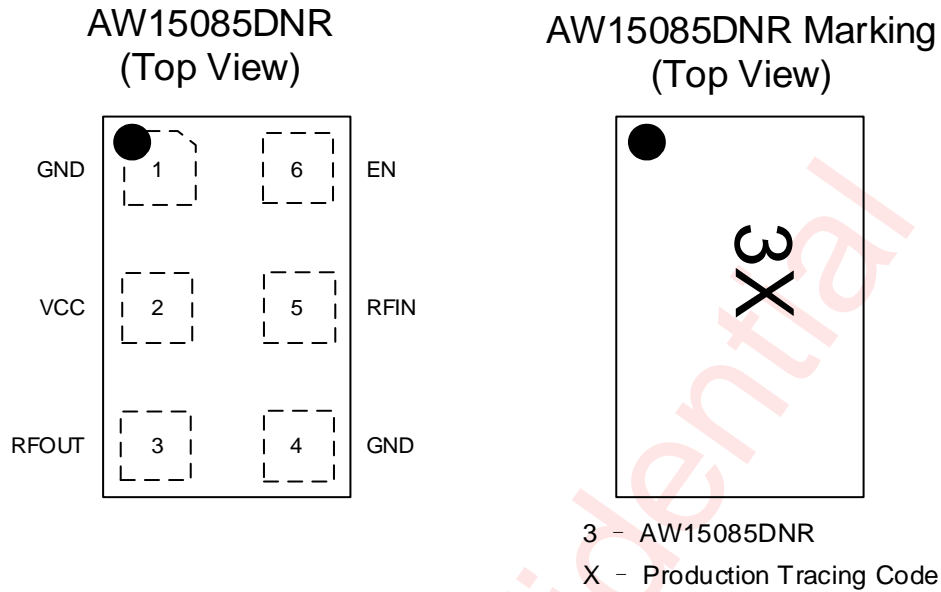

Pin Configuration and Top Mark

## Pin Definition

No.	NAME	DESCRIPTION
1	GND	Ground
2	VCC	DC Supply
3	RFOUT	LNA output
4	GND	Ground
5	RFIN	LNA input
6	EN	Logic control

## Functional Block Diagram

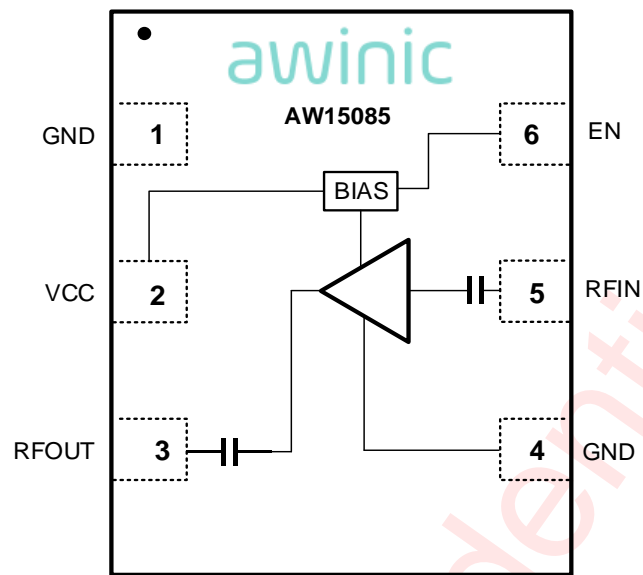

Functional Block Diagram

## Ordering Information

Part Number	Temperature	Package	Marking	Moisture Sensitivity Level	Environmental Information	Delivery Form
AW15085DNR	-40°C ~ 85°C	DFN 1.1mmX0.7mm-6L	3	MSL1	ROHS+HF	3000 units/ Tape and Reel

Absolute Maximum Ratings<sup>[1]</sup>

PARAMETERS	Symbol	Values			Unit
		Min.	Typ.	Max.	
Supply Voltage at pin VCC	VCC	-0.3	-	3.3	V
Voltage at pin EN <sup>[2]</sup>	V <sub>EN</sub>	-0.3	-	3.3	V
Current into pin VCC	I <sub>CC</sub>	-	-	10	mA
RF input power <sup>[3]</sup>	P <sub>IN</sub>	-	-	0	dBm
Junction temperature	T <sub>J</sub>	-	-	150	°C
Storage temperature range	T <sub>STG</sub>	-65	-	150	°C
Ambient temperature range	T <sub>amb</sub>	-40	-	85	°C
Solder temperature(10s)		-	260	-	°C
ESD range					
HBM <sup>[4]</sup>			±2		kV
CDM <sup>[5]</sup>			±1		kV
Latch-up					
Test condition: JESD78E			+IT: +200 -IT: -200		mA mA

NOTE1: Conditions out of those ranges listed in "absolute maximum ratings" may cause permanent damages to the device. In spite of the limits above, functional operation conditions of the device should within the ranges listed in "recommended operating conditions". Exposure to absolute-maximum-rated conditions for prolonged periods may affect device reliability.

NOTE2: Warning: due to internal ESD diode protection, the applied DC voltage should not exceed 3.3V in order to avoid excess current.

NOTE3: The RF input and RF output are AC coupled through internal DC blocking capacitor.

NOTE4: HBM standard: ESDA/JEDEC JS-001.

NOTE5: CDM standard: ESDA/JEDEC JS-002.

## Electrical Characteristics

AW15085 EVB<sup>[1]</sup>;  $V_{CC}=V_{EN}=2.8\text{ V}$  and  $T_A=+25\text{ }^\circ\text{C}$ ,  $f=1575.42\text{ MHz}$ ; unless otherwise noted

PARAMETER	TEST CONDITION	MIN	TYP	MAX	UNIT		
<b>DC ELECTRICAL CHARACTERISTICS</b>							
$V_{CC}$	Supply Voltage	1.5	-	3.1	V		
$I_{SD}$	Shut-Down Current		EN=Low	-	2	$\mu\text{A}$	
$I_{CC}$	Supply Current		EN=High	-	1.2	1.85	mA
$V_{EN}$	Digital Input-Logic High	1.0	-	-	V		
$V_{EN}$	Digital Input-Logic Low	-	-	0.3	V		
<b>AC ELECTRICAL CHARACTERISTICS</b>							
$G_p$	Power Gain	15	18.2	20.5	dB		
$RL_{in}$	Input Return Loss	6	10	-	dB		
$RL_{out}$	Output Return Loss	6	15	-	dB		
ISL	Reverse Isolation	20	30	-	dB		
NF	Noise Figure <sup>[2]</sup>		$Z_s=50\text{ ohm};$ No jammer	-	0.7	1.2	dB
Kf	Stability factor		$f=0.1\text{-}10\text{GHz}$	1	-	-	
IP1dB	Inband input 1dB-compression point		$f=1575.42\text{MHz}$	-12	-7	-	dBm
IIP3 <sub>ib</sub>	Inband input 3 <sup>rd</sup> -order intercept point <sup>[3]</sup>		$f_1=1574.42\text{MHz};$ $f_2=1575.42\text{MHz};$	-10	-5	-	dBm
IIP3 <sub>oob</sub>	Out-of-band input 3 <sup>rd</sup> -order intercept point <sup>[4]</sup>		$f_1=1712.7\text{MHz};$ $f_2=1850\text{MHz};$	-14	-7	-	dBm
$t_{on}$	turn-on time		time from $V_{EN}$ ON to 90% of the final gain	-	-	2	$\mu\text{s}$
$t_{off}$	turn-off time		time from $V_{EN}$ OFF to 10% of the gain	-	-	1	$\mu\text{s}$

NOTE1: input matched to 50 ohm using a high quality factor 12 nH inductor.

NOTE2: PCB losses are subtracted.

NOTE3: Input power = -20 dBm for each tone.

NOTE4: Input power = -20 dBm at  $f_1$  and -65 dBm at  $f_2$ .

AW15085 EVB<sup>[1]</sup>;  $V_{CC}=V_{EN}=1.8$  V and  $T_A=+25$  °C,  $f=1575.42$  MHz; unless otherwise noted

PARAMETER	TEST CONDITION	MIN	TYP	MAX	UNIT		
<b>DC ELECTRICAL CHARACTERISTICS</b>							
$V_{CC}$	Supply Voltage	1.5	-	3.1	V		
$I_{SD}$	Shut-Down Current	EN=Low		-	2	$\mu$ A	
$I_{CC}$	Supply Current	EN=High		-	1.2	1.8	mA
$V_{EN}$	Digital Input-Logic High	1.0	-	-	V		
$V_{EN}$	Digital Input-Logic Low	-	-	0.3	V		
<b>AC ELECTRICAL CHARACTERISTICS</b>							
$G_p$	Power Gain	15	17.7	20	dB		
$RL_{in}$	Input Return Loss	6	10	-	dB		
$RL_{out}$	Output Return Loss	6	15	-	dB		
ISL	Reverse Isolation	20	30	-	dB		
NF	Noise Figure <sup>[2]</sup>	Zs=50 ohm; No jammer		-	0.75	1.25	dB
Kf	Stability factor	f=0.1-10GHz		1	-	-	
IP1dB	Inband input 1dB-compression point	f=1575.42MHz		-15	-10	-	dBm
IIP3 <sub>ib</sub>	Inband input 3 <sup>rd</sup> -order intercept point <sup>[3]</sup>	f1=1574.42MHz; f2=1575.42MHz;		-10	-5	-	dBm
IIP3 <sub>oob</sub>	Out-of-band input 3 <sup>rd</sup> -order intercept point <sup>[4]</sup>	f1=1712.7MHz; f2=1850MHz;		-14	-7	-	dBm
$t_{on}$	turn-on time	time from $V_{EN}$ ON to 90% of the final gain		-	-	2	$\mu$ s
$t_{off}$	turn-off time	time from $V_{EN}$ OFF to 10% of the gain		-	-	1	$\mu$ s

NOTE1: input matched to 50 ohm using a high quality factor 12 nH inductor.

NOTE2: PCB losses are subtracted.

NOTE3: Input power = -20 dBm for each tone.

NOTE4: Input power = -20 dBm at f1 and -65 dBm at f2.



AW15085 EVB<sup>[1]</sup>;  $V_{CC}=V_{EN}=2.8$  V and  $T_A=+25$  °C,  $f=1176.45$  MHz; unless otherwise noted

PARAMETER	TEST CONDITION	MIN	TYP	MAX	UNIT	
<b>DC ELECTRICAL CHARACTERISTICS</b>						
$V_{CC}$	Supply Voltage	1.5	-	3.1	V	
$I_{SD}$	Shut-Down Current	EN=Low	-	2	$\mu$ A	
$I_{CC}$	Supply Current	EN=High	-	1.2	mA	
$V_{EN}$	Digital Input-Logic High	1.0	-	-	V	
$V_{EN}$	Digital Input-Logic Low	-	-	0.3	V	
<b>AC ELECTRICAL CHARACTERISTICS</b>						
$G_p$	Power Gain	14	17.5	19.5	dB	
$RL_{in}$	Input Return Loss	6	10	-	dB	
$RL_{out}$	Output Return Loss	6	15	-	dB	
ISL	Reverse Isolation	25	35	-	dB	
NF	Noise Figure <sup>[2]</sup>	Zs=50 ohm; No jammer	-	0.7	1.2	dB
Kf	Stability factor	f=0.1-10GHz	1	-	-	
IP1dB	Inband input 1dB-compression point	f=1176.45MHz	-15	-10	-	dBm
IIP3 <sub>ib</sub>	Inband input 3 <sup>rd</sup> -order intercept point <sup>[3]</sup>	f1=1175.45MHz; f2=1176.45MHz;	-12	-7	-	dBm
IIP3 <sub>oob</sub>	Out-of-band input 3 <sup>rd</sup> -order intercept point <sup>[4]</sup>	f1=1800MHz; f2=2400MHz;	-3	3.5	-	dBm
$t_{on}$	turn-on time	time from $V_{EN}$ ON to 90% of the final gain	-	-	2	$\mu$ s
$t_{off}$	turn-off time	time from $V_{EN}$ OFF to 10% of the gain	-	-	1	$\mu$ s

NOTE1: input matched to 50 ohm using a high quality factor 20 nH inductor. Output matching using 12nH inductor and 3.3pF capacitor.

NOTE2: PCB losses are subtracted.

NOTE3: Input power = -20 dBm for each tone.

NOTE4: Input power = -25 dBm for each tone.

AW15085 EVB<sup>[1]</sup>;  $V_{CC}=V_{EN}=1.8$  V and  $T_A=+25$  °C,  $f=1176.45$  MHz; unless otherwise noted

PARAMETER	TEST CONDITION	MIN	TYP	MAX	UNIT	
<b>DC ELECTRICAL CHARACTERISTICS</b>						
$V_{CC}$	Supply Voltage	1.5	-	3.1	V	
$I_{SD}$	Shut-Down Current	EN=Low	-	2	$\mu$ A	
$I_{CC}$	Supply Current	EN=High	-	1.2	mA	
$V_{EN}$	Digital Input-Logic High	1.0	-	-	V	
$V_{EN}$	Digital Input-Logic Low	-	-	0.3	V	
<b>AC ELECTRICAL CHARACTERISTICS</b>						
$G_p$	Power Gain	13.5	17	19	dB	
$RL_{in}$	Input Return Loss	6	10	-	dB	
$RL_{out}$	Output Return Loss	6	15	-	dB	
ISL	Reverse Isolation	25	35	-	dB	
NF	Noise Figure <sup>[2]</sup>	Zs=50 ohm; No jammer	-	0.75	1.25	dB
Kf	Stability factor	f=0.1-10GHz	1	-	-	
IP1dB	Inband input 1dB-compression point	f=1176.45MHz	-19	-14	-	dBm
IIP3 <sub>ib</sub>	Inband input 3 <sup>rd</sup> -order intercept point <sup>[3]</sup>	f1=1175.45MHz; f2=1176.45MHz;	-15	-10	-	dBm
IIP3 <sub>oob</sub>	Out-of-band input 3 <sup>rd</sup> -order intercept point <sup>[4]</sup>	f1=1800MHz; f2=2400MHz;	-3	3.5	-	dBm
$t_{on}$	turn-on time	time from $V_{EN}$ ON to 90% of the final gain	-	-	2	$\mu$ s
$t_{off}$	turn-off time	time from $V_{EN}$ OFF to 10% of the gain	-	-	1	$\mu$ s

NOTE1: input matched to 50 ohm using a high quality factor 20 nH inductor. Output matching using 12nH inductor and 3.3pF capacitor.

NOTE2: PCB losses are subtracted.

NOTE3: Input power = -20 dBm for each tone.

NOTE4: Input power = -25 dBm for each tone.

Package Description

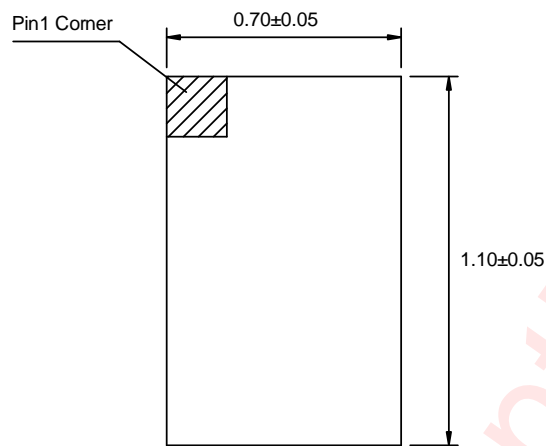

TOP VIEW

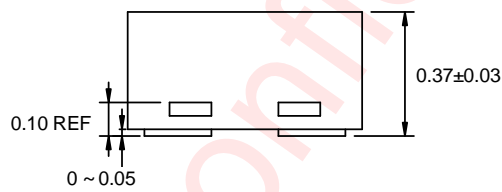

SIDE VIEW

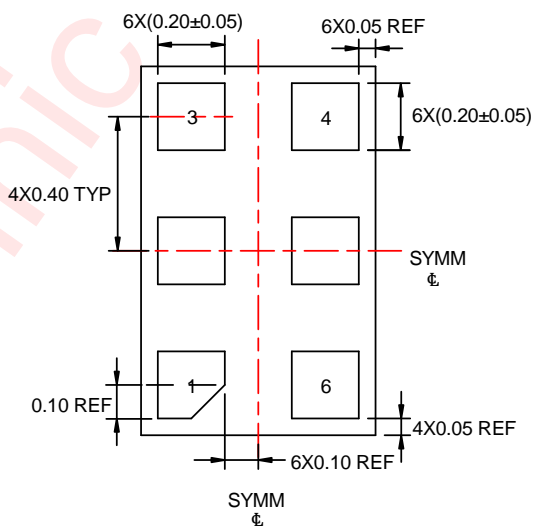

BOTTOM VIEW

Unit: mm

Package Outline

Land Pattern

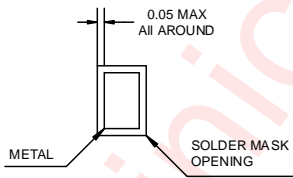
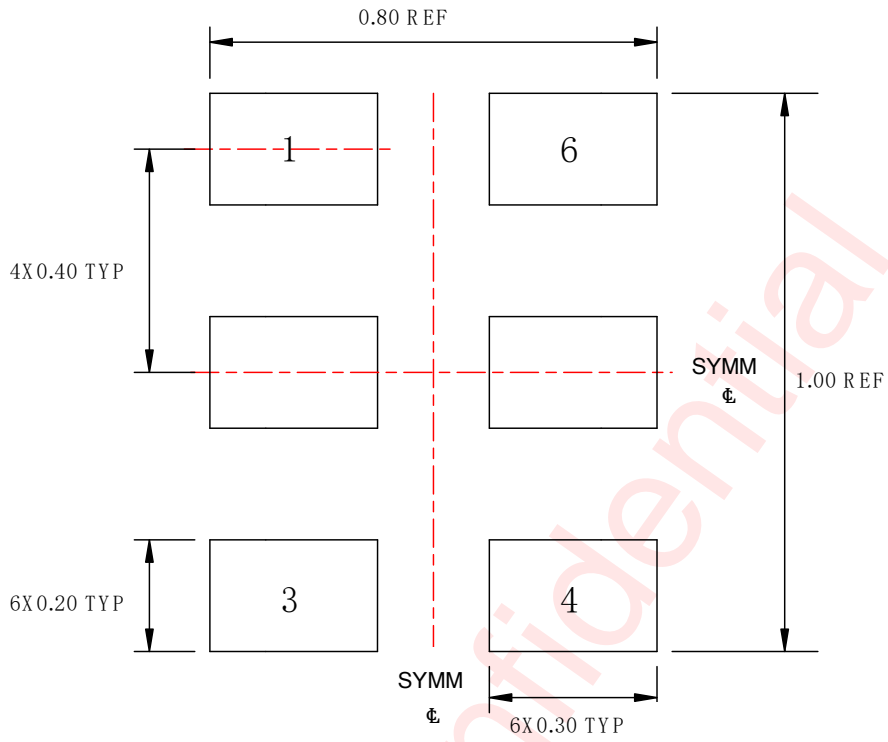

NON-SOLDER MASK DEFINED

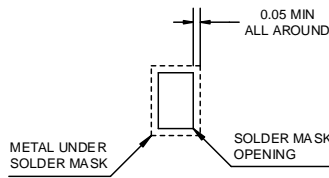

SOLDER MASK DEFINED

Unit: mm

Land Pattern

### Tape & Reel Description

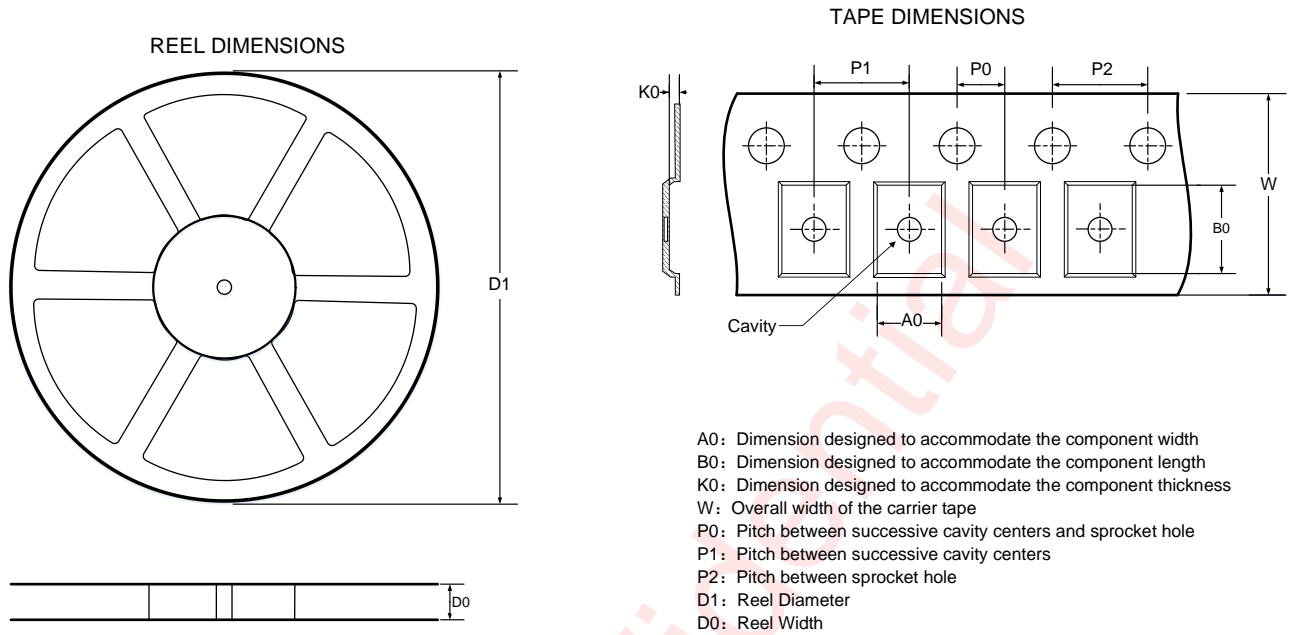

#### QUADRANT ASSIGNMENTS FOR PIN 1 ORIENTATION IN TAPE

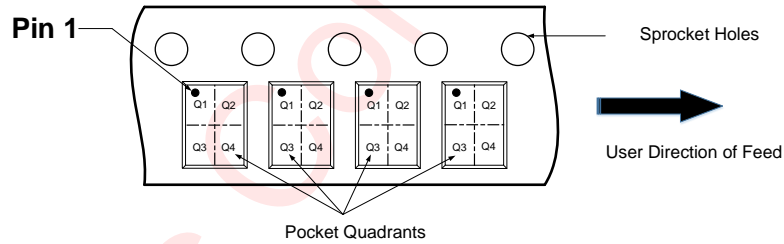

#### DIMENSIONS AND PIN1 ORIENTATION

D1 (mm)	D0 (mm)	A0 (mm)	B0 (mm)	K0 (mm)	P0 (mm)	P1 (mm)	P2 (mm)	W (mm)	Pin1 Quadrant
178	8.4	0.82	1.22	0.46	2	2	4	8	Q1

All dimensions are nominal

### Tape & Reel Description

## Revision History

Version	Date	Change Record
V1.0	Mar. 2020	Officially Released
V1.1	May. 2020	Add GPS L5
V1.2	May. 2021	Add Spec

awinic Confidential

## Disclaimer

All trademarks are the property of their respective owners. Information in this document is believed to be accurate and reliable. However, Shanghai AWINIC Technology Co., Ltd (AWINIC Technology) does not give any representations or warranties, expressed or implied, as to the accuracy or completeness of such information and shall have no liability for the consequences of use of such information.

AWINIC Technology reserves the right to make changes to information published in this document, including without limitation specifications and product descriptions, at any time and without notice. Customers shall obtain the latest relevant information before placing orders and shall verify that such information is current and complete. This document supersedes and replaces all information supplied prior to the publication hereof.

AWINIC Technology products are not designed, authorized or warranted to be suitable for use in medical, military, aircraft, space or life support equipment, nor in applications where failure or malfunction of an AWINIC Technology product can reasonably be expected to result in personal injury, death or severe property or environmental damage. AWINIC Technology accepts no liability for inclusion and/or use of AWINIC Technology products in such equipment or applications and therefore such inclusion and/or use is at the customer's own risk.

Applications that are described herein for any of these products are for illustrative purposes only. AWINIC Technology makes no representation or warranty that such applications will be suitable for the specified use without further testing or modification.

All products are sold subject to the general terms and conditions of commercial sale supplied at the time of order acknowledgement.

Nothing in this document may be interpreted or construed as an offer to sell products that is open for acceptance or the grant, conveyance or implication of any license under any copyrights, patents or other industrial or intellectual property rights.

Reproduction of AWINIC information in AWINIC data books or data sheets is permissible only if reproduction is without alteration and is accompanied by all associated warranties, conditions, limitations, and notices. AWINIC is not responsible or liable for such altered documentation. Information of third parties may be subject to additional restrictions.

Resale of AWINIC components or services with statements different from or beyond the parameters stated by AWINIC for that component or service voids all express and any implied warranties for the associated AWINIC component or service and is an unfair and deceptive business practice. AWINIC is not responsible or liable for any such statements.

## X-ON Electronics

Largest Supplier of Electrical and Electronic Components

*Click to view similar products for [Operational Amplifiers - Op Amps category](#):*

*Click to view products by [Awinic manufacturer](#):*

Other Similar products are found below :

[430227FB](#) [LT1678IS8](#) [NCV33202DMR2G](#) [NJM324E](#) [M38510/13101BPA](#) [NTE925](#) [AZV358MTR-G1](#) [AP4310AUMTR-AG1](#)  
[AZV358MMTR-G1](#) [SCY33178DR2G](#) [NCV20034DR2G](#) [NTE778S](#) [NTE871](#) [NTE937](#) [NJU7057RB1-TE2](#) [SCY6358ADR2G](#)  
[NJM2904CRB1-TE1](#) [UPC4570G2-E1-A](#) [UPC4741G2-E1-A](#) [NJM8532RB1-TE1](#) [EL2250CS](#) [EL5100IS](#) [EL5104IS](#) [EL5127CY](#) [EL5127CYZ](#)  
[EL5133IW](#) [EL5152IS](#) [EL5156IS](#) [EL5162IS](#) [EL5202IY](#) [EL5203IY](#) [EL5204IY](#) [EL5210CS](#) [EL5210CYZ](#) [EL5211IYE](#) [EL5220CY](#)  
[EL5223CLZ](#) [EL5223CR](#) [EL5224ILZ](#) [EL5227CLZ](#) [EL5227CRZ](#) [EL5244CS](#) [EL5246CS](#) [EL5246CSZ](#) [EL5250IY](#) [EL5251IS](#) [EL5257IS](#)  
[EL5260IY](#) [EL5261IS](#) [EL5300IU](#)