

## 3-Key Capacitive Touch Controller

### FEATURES

- 3 Capacitive key with sensitivity configurable
- RF Noise Filter
- Tap Gesture detection (Single/Double/Triple click)
- Automatic Calibration for Environmental Change
- Intrinsic Capacitance Compensation
- Compatible I<sup>2</sup>C Interface, V<sub>IO</sub>: 1.8V ~ 3.3V
- I2C Address: 0x2C/0x2D
- Single Power Supply, Voltage Range: 3.0V ~ 4.5V
- CSP1.59mm×1.75mm×0.57mm-13L Package

### GENERAL DESCRIPTION

AW9203 integrates 3 capacitive sensor. The capacitive sensor takes advantage of advanced Sigma-delta capacitance digital conversion technology to achieve high sensitivity and anti-noise capacitance detection. With internal DSP algorithm, the touch and gesture event can be detected and reported in status register and external interrupt pin.

Compatible I<sup>2</sup>C interface of 400kHz fast mode is provided, the package is CSP1.59mm×1.75mm-13L. It requires only 3.0V-4.5V single power supply.

### APPLICATIONS

Mobile Phones, MID  
Portable Media Player  
Home Appliances

### TYPICAL APPLICATION CIRCUIT

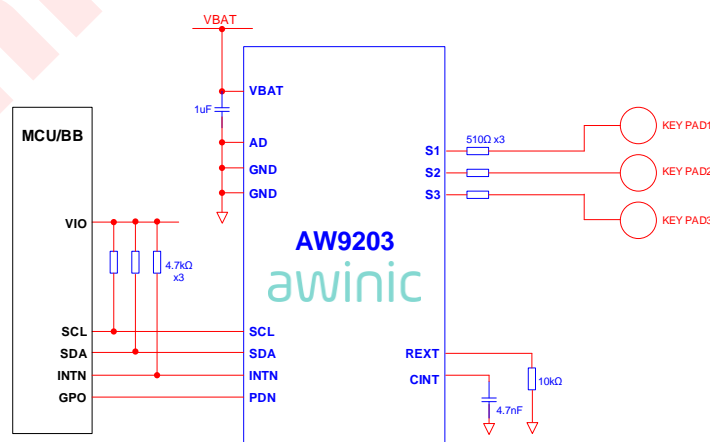

Figure 1 AW9203 Typical Application Circuit

All trademarks are the property of their respective owners.

## CONTENT

<b>1</b>	<b>PIN CONFIGURATION AND TOP MARK</b>	<b>4</b>
<b>2</b>	<b>PIN DEFINITION</b>	<b>4</b>
<b>3</b>	<b>FUNCTIONAL BLOCK DIAGRAM</b>	<b>5</b>
<b>4</b>	<b>TYPICAL APPLICATION CIRCUITS</b>	<b>5</b>
<b>5</b>	<b>ORDERING INFORMATION</b>	<b>6</b>
<b>6</b>	<b>ABSOLUTE MAXIMUM RATINGS<sup>(NOTE 3)</sup></b>	<b>6</b>
<b>7</b>	<b>ELECTRICAL CHARACTERISTICS</b>	<b>7</b>
<b>8</b>	<b>I<sup>2</sup>C INTERFACE TIMING</b>	<b>8</b>
<b>9</b>	<b>FUNCTIONAL DESCRIPTION</b>	<b>9</b>
9.1	WORK MODE	9
9.1.1	POWER ON	9
9.1.2	WORK MODE	9
9.2	RESET	10
9.2.1	HARDWARE RESET	10
9.2.2	SOFTWARE RESET	10
9.3	I <sup>2</sup> C INTERFACE	10
9.3.1	DEVICE ADDRESS	10
9.3.2	DATA VALIDATION	10
9.3.3	ACK(ACKNOWLEDGEMENT)	10
9.3.4	I <sup>2</sup> C START/STOP	11
9.3.5	WRITE CYCLE	11
9.3.6	READ CYCLE	12
9.4	OSCILLATOR	13
9.5	CAPACITIVE TOUCH DETECTION	13
9.5.1	TOUCH STATUS AND INTERRUPT	13
9.5.2	GESTURE STATUS	14
<b>10</b>	<b>REGISTER DESCRIPTION</b>	<b>15</b>
10.1	REGISTER CONFIGURATION	15
10.2	GLOBAL REGISTER DESCRIPTION	17
10.2.1	IDRST, CHIP ID AND SOFTWARE RESET	17
10.2.2	GCR, GLOBAL CONTROL REGISTER	17
10.3	CAPACITIVE TOUCH DETECTION REGISTERS	17
10.3.1	SLPR, SENSOR SLEEP CONTROL REGISTER	17
10.3.2	KINTER, KEY INTERRUPT ENABLE REGISTER	17
10.3.3	AKSCR, ADJACENT KEY SUPPRESSION CONFIGURATION REGISTER	17
10.3.4	SLSR, SLIDE CONFIGURATION REGISTER	18
10.3.5	JDGTHRN, KEY STATUS JUDGE CONFIGURATION REGISTER	18
10.3.6	NOISETHR, NOISE THRESHOLD REGISTER	18

10.3.7	SCFG1, SCAN CONFIGURATION REGISTER.....	18
10.3.8	SCFG2, SCAN CONFIGURATION REGISTER.....	18
10.3.9	OFSR1, KEY CAPACITANCE OFFSET REGISTER.....	19
10.3.10	OFSR2, KEY CAPACITANCE OFFSET REGISTER.....	19
10.3.11	DOFCR1-2, ADC DIGITAL OFFSET REGISTER.....	19
10.3.12	IDLECR, IDLE STATUS CONFIGURATION REGISTER.....	19
10.3.13	MTOTR, MAXIMUM TOUCH ON TIME REGISTER.....	20
10.3.14	DISMAX, MAXIMUM MARGIN OF VALID DATA.....	20
10.3.15	SETCNT, TOUCH DECISION DE-BOUNCE COUNT.....	20
10.3.16	BLCTH, BASELINE TRACE CONFIGURATION REGISTER.....	20
10.3.17	BLDTH, BASELINE RESET THRESHOLD.....	20
10.3.18	MCR, MONITOR CONTROL REGISTER.....	21
10.3.19	GDCFGR, GESTURE DETECTION CONFIGURATION REGISTER.....	21
10.3.20	GDTR, GESTURE DETECTION TIME REGISTER.....	21
10.3.21	TDTR, TAP DETECTION REGISTER.....	21
10.3.22	GSTR1~2, GESTURE CONFIGURATION REGISTER.....	21
10.3.23	TAPR, TAP GESTURE CONFIGURATION REGISTER.....	22
10.3.24	GIER, GESTURE INTERRUPT ENABLE REGISTER.....	22
10.3.25	GISR, GESTURE INTERRUPT STATUS REGISTER.....	22
10.3.26	GTIMR, GESTURE DURATION REGISTER.....	23
10.3.27	RAWST, RAW KEY STATUS REGISTER.....	23
10.3.28	KEYST, AKS KEY STATUS REGISTER.....	23
10.3.29	KISR, KEY INTERRUPT STATUS REGISTER.....	23
10.3.30	MOVCNTR, SLIDER MOVE COUNTER REGISTER.....	23
10.3.31	KDATAN, KEY DATA REGISTER.....	23
10.3.32	DUM0, RESERVED REGISTER.....	24
10.3.33	DUM1, RESERVED REGISTER.....	24
<b>11</b>	<b>TAPE AND REEL INFORMATION.....</b>	<b>25</b>
11.1	CARRIER TAPE.....	25
11.2	PIN1 DIRECTION.....	25
11.3	REEL.....	26
<b>12</b>	<b>PACKAGE DESCRIPTION.....</b>	<b>27</b>
<b>13</b>	<b>RECOMMENDED LAND PATTERN.....</b>	<b>27</b>
<b>14</b>	<b>REFLOW.....</b>	<b>28</b>
<b>15</b>	<b>REVISION HISTORY.....</b>	<b>29</b>
<b>16</b>	<b>DISCLAIMER.....</b>	<b>30</b>

## 1 PIN CONFIGURATION AND TOP MARK

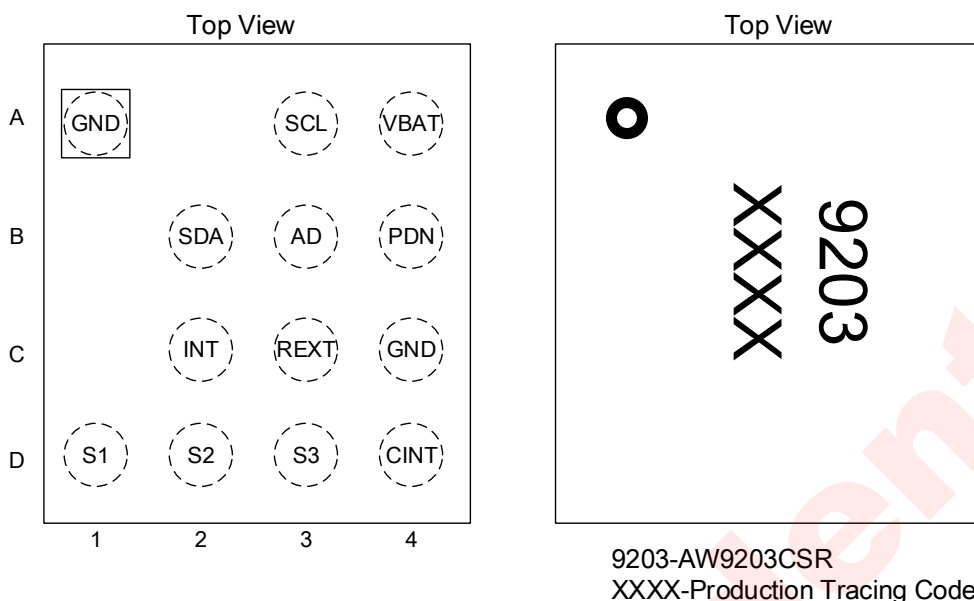

## 2 PIN DEFINITION

No.	NAME	DESCRIPTION
A1	GND	Ground
A3	SCL	Clock input of I <sup>2</sup> C Interface
A4	VBAT	Power supply (3.0V to 4.5V)
B2	SDA	Data I/O of I <sup>2</sup> C Interface
B3	AD	I <sup>2</sup> C Address Select
B4	PDN	Power-down input , low active, internal 1MΩ pull-down resistor
C2	INTN	Open-drain Interrupt output, low active. Typically connected to VIO via a 4.7kΩ resistor
C3	REXT	External resistor for adjusting sensitivity (typical is 10kΩ)
C4	GND	Ground
D1	S1	Capacitive Touch Input S1
D2	S2	Capacitive Touch Input S2
D3	S3	Capacitive Touch Input S3
D4	CINT	External reference capacitor(typical is 4.7nF)

### 3 FUNCTIONAL BLOCK DIAGRAM

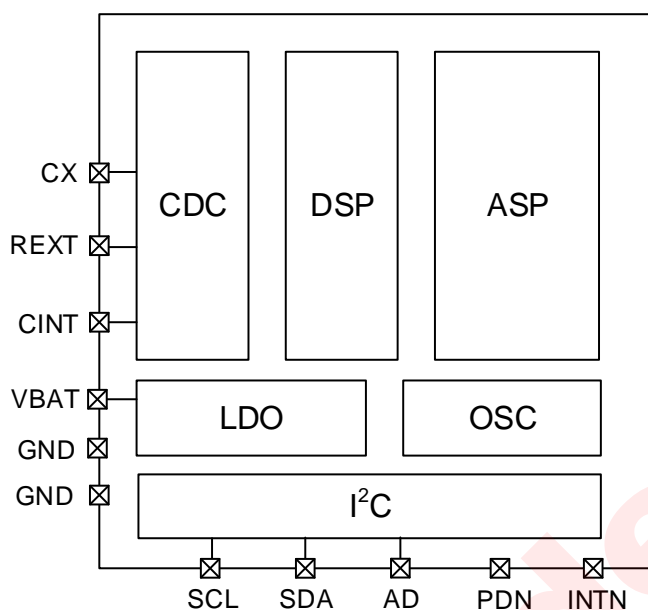

Figure 2 FUNCTIONAL BLOCK DIAGRAM

### 4 TYPICAL APPLICATION CIRCUITS

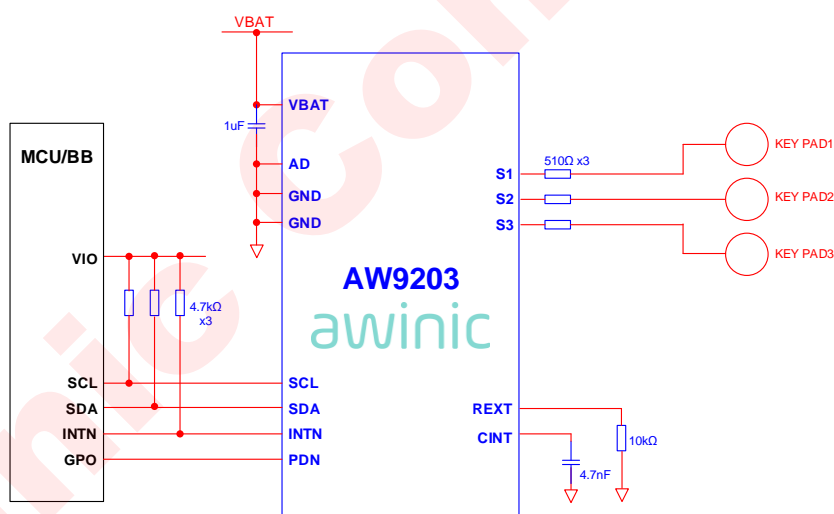

Figure 3 AW9203 Typical Application Circuit

NOTE1、 Pin S1/S2/S3 must connect a 500Ω ~ 600Ω resistor.

NOTE2、  $C_{INT}$  and  $R_{EXT}$  should be placed as close as possible to the chip.

## 5 ORDERING INFORMATION

Part Number	Temperature	Package	Marking	Moisture Sensitivity Level	Environmental Information	Delivery Form
AW9203CSR	-40°C~85°C	CSP1.59x1.75-13L	9203	MSL1	ROHS+HF	3000 units/ Tape and Reel

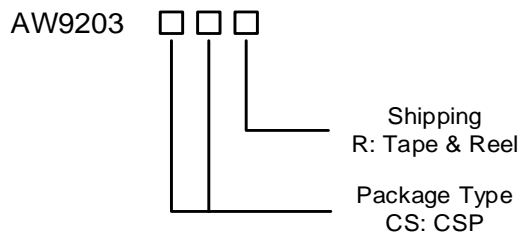

## 6 ABSOLUTE MAXIMUM RATINGS<sup>(NOTE 3)</sup>

PARAMETERS		RANGE
Supply voltage range $V_{BAT}$		-0.3V to 5V
Input voltage range	SCL, SDA	-0.3V to 3.6V
	PDN	-0.3V to 4.5V
Output voltage range	SDA, INTN	-0.3V to 3.6V
Junction-to-ambient thermal resistance $\theta_{JA}$		45°C/W
Operating free-air temperature range		-40°C to 85°C
Maximum Junction temperature $T_{JMAX}$		150°C
Storage temperature $T_{STG}$		-65°C to 150°C
Lead Temperature (Soldering 10 Seconds)		260°C
ESD <sup>(NOTE 4)</sup>		
HBM (human body model)		±8000V
CDM (charge device mode)		±2000V
Latch-up		
Test Condition: JEDEC STANDARD NO.78B DECEMBER 2008		+IT: 450mA -IT: -450mA

**NOTE3:** Conditions out of those ranges listed in "absolute maximum ratings" may cause permanent damages to the device. In spite of the limits above, functional operation conditions of the device should within the ranges listed in "recommended operating conditions". Exposure to absolute-maximum-rated conditions for prolonged periods may affect device reliability.

**NOTE4:** The human body model is a 100pF capacitor discharged through a 1.5kΩ resistor into each pin. Test method: MIL-STD-883G Method 3015.7

## 7 ELECTRICAL CHARACTERISTICS

V<sub>BAT</sub>=3.8V, T<sub>A</sub>=25°C for typical values (unless otherwise noted)

PARAMETER	TEST CONDITION	MIN	TYP	MAX	UNIT
V <sub>BAT</sub>	Power supply	3.0	3.8	4.5	V
I <sub>SHUTDOWN</sub>	Current in Shutdown mode	PDN=GND	8	15	μA
I <sub>STANDBY</sub>	Current in Standby mode	PDN=1.8V	130	160	μA
I <sub>ACTIVE</sub>	Current in Active mode	PDN=1.8V, GCR=0x02	0.85	1.0	mA
F <sub>OSC</sub>	Internal oscillator Frequency accuracy (16MHz)	14.8	16	17.2	MHz
<b>Digital Logical Interface</b>					
V <sub>IL</sub>	Logic input low level	SDA,SCL,PDN		0.45	V
V <sub>IH</sub>	Logic input high level	SDA,SCL,PDN	1.1		V
I <sub>IL</sub>	Low level input current	SDA,SCL,PDN		5	nA
I <sub>IH</sub>	High level input current	SDA,SCL,PDN		5	nA
V <sub>OL</sub>	Logic output low level	SDA, INTN I <sub>OUT</sub> =3mA		0.4	V
I <sub>OL</sub>	Maximum output current	SDA, INTN		10	mA
I <sub>L</sub>	Output leakage current	SDA,INTN open drain		1	μA
<b>I<sup>2</sup>C Interface</b>					
F <sub>SCL</sub>	I <sup>2</sup> C-BUS clock frequency			400	kHz
T <sub>Deglitch</sub>	SCL deglitch time		200		ns
	SDA deglitch time		250		ns
<b>Capacitance Button</b>					
SX <sub>range</sub>	Range <sup>(NOTE5)</sup>	SX	0	80	pF
SX <sub>resolution</sub>	Resolution <sup>(NOTE5)</sup>	SX	0.02		pF
F <sub>SCAN</sub>	Scan frequency		30		Hz
T <sub>DET</sub>	Response time		100		ms

NOTE5: the value is tested in default configuration.

## 8 I<sup>2</sup>C INTERFACE TIMING

Parameter Name		MIN	TYP	MAX	UNIT
F <sub>SCL</sub>	Interface Clock frequency			400	kHz
T <sub>DEGLITCH</sub>	Deglitch time	SCL	200		ns
		SDA	250		ns
T <sub>HD:STA</sub>	(Repeat-start) Start condition hold time	0.6			μs
T <sub>LOW</sub>	Low level width of SCL	1.3			μs
T <sub>HIGH</sub>	High level width of SCL	0.6			μs
T <sub>SU:STA</sub>	(Repeat-start) Start condition setup time	0.6			μs
T <sub>HD:DAT</sub>	Data hold time	0			μs
T <sub>SU:DAT</sub>	Data setup time	0.1			μs
T <sub>R</sub>	Rising time of SDA and SCL			0.3	μs
T <sub>F</sub>	Falling time of SDA and SCL			0.3	μs
T <sub>SU:STO</sub>	Stop condition setup time	0.6			μs
T <sub>BUF</sub>	Time between start and stop condition	1.3			μs

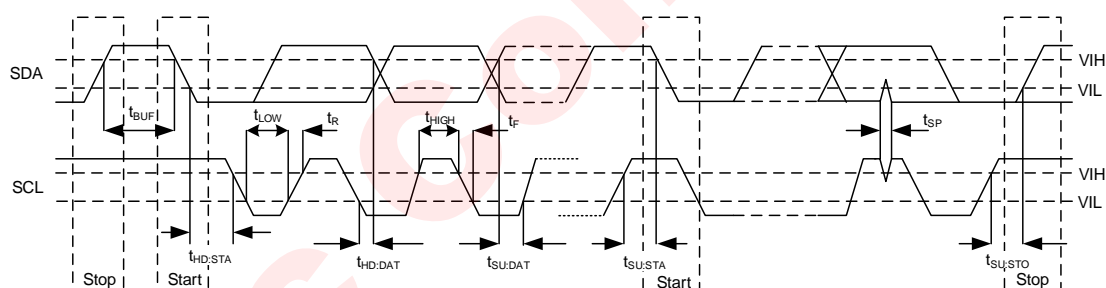



## 9 FUNCTIONAL DESCRIPTION

### 9.1 WORK MODE

#### 9.1.1 Power On

After power-up, about 100 $\mu$ s delay is required before PDN set to high, otherwise, the device may work incorrectly. The minimal wait time for I<sup>2</sup>C communication is 5ms, during this period, some internal modules (such as LDO) start to work and reach a stable state.

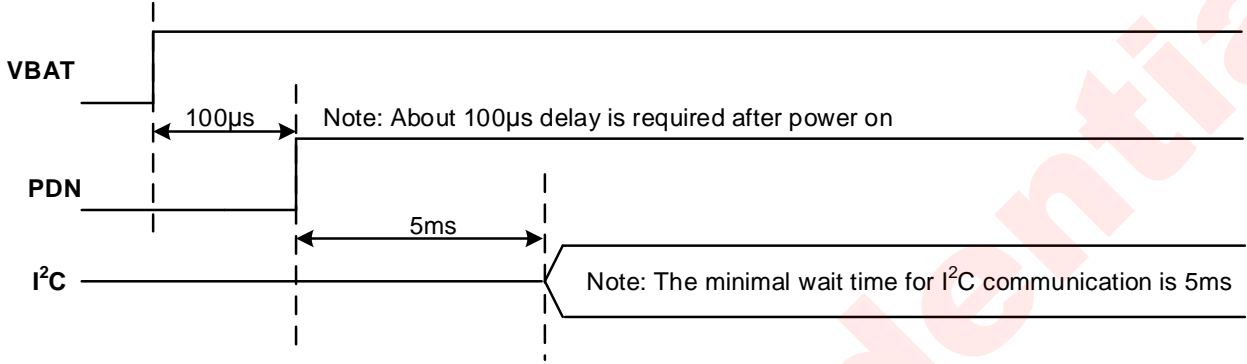

Figure 4 AW9203 Power On

#### 9.1.2 Work Mode

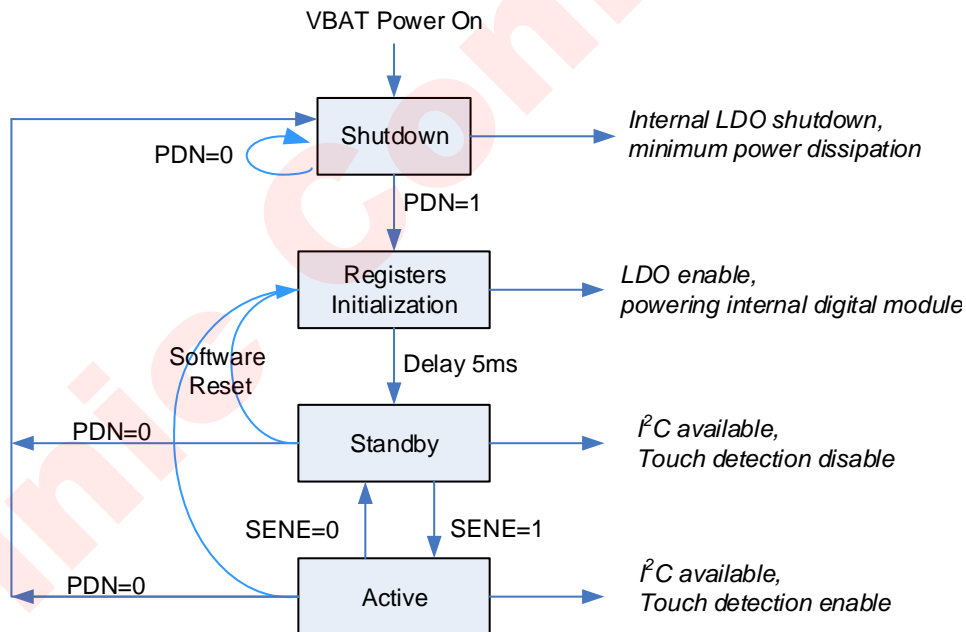

Figure 5 AW9203 Work Mode

After VBAT powered on, if PDN pin is low, the AW9203 is in shut-down mode, the current consumption is less than 15 $\mu$ A. When PDN pin becomes high, the internal LDO is activated, and a power-on reset (POR) signal is generated to initialize all internal registers, the device enters standby mode, this is a low power consumption mode, when all circuit functions are disabled. In standby mode, I<sup>2</sup>C interface is active, all internal configuration register can be written. If control bit GCR.SENE is written high, the device enters the active mode.

## 9.2 RESET

### 9.2.1 Hardware Reset

When PDN pin changes from low to high, the power-up reset (POR) signal is generated, all internal registers are reset.

### 9.2.2 Software Reset

Writing 0x55AA to register RSTR (0x00) via I<sup>2</sup>C interface will activate a software reset to reset all internal registers.

## 9.3 I<sup>2</sup>C INTERFACE

AW9203 supports the I<sup>2</sup>C serial bus and data transmission protocol in fast mode at 400kHz. It operates as a slave on the I<sup>2</sup>C bus. Connections to the bus are made via the open-drain I/O pins SCL and SDA. The pull-up resistor can be selected in the range of 1k~10kΩ and the typical value is 4.7kΩ. AW9203 can support different high level (1.8V~3.3V) of this I<sup>2</sup>C interface.

### 9.3.1 Device Address

The I<sup>2</sup>C device address (7-bit, followed by the R/W bit(Read=1/Write=0)) of AW9203 depends on the AD pin status. When AD level is low, the I<sup>2</sup>C address is 0x2C; when AD level is high, the I<sup>2</sup>C address is 0x2D.

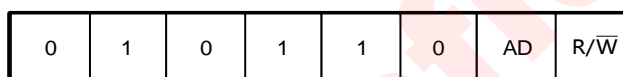

Figure 6 Device Address Configuration

### 9.3.2 Data Validation

When SCL is high level, SDA level must be constant. SDA can be changed only when SCL is low level.

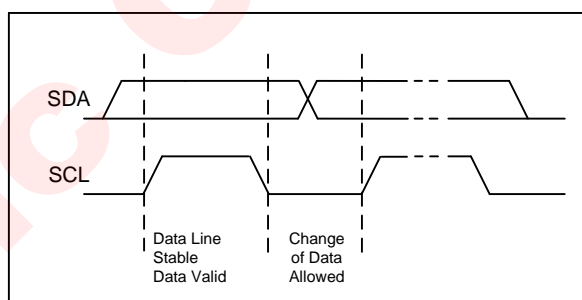

Figure 7 Data Validation Diagram

### 9.3.3 ACK(Acknowledgement)

ACK means the successful transfer of I<sup>2</sup>C bus data. After master sends 8bits data, SDA must be released; SDA is pulled to GND by slave device when slave acknowledges.

When master reads, AW9203 sends 8bit data, releases the SDA and waits for ACK from master. If ACK is send and I<sup>2</sup>C stop is not send by master, AW9203 sends the next data. If ACK is not send by master, AW9203 stops to send data and waits for I<sup>2</sup>C stop.

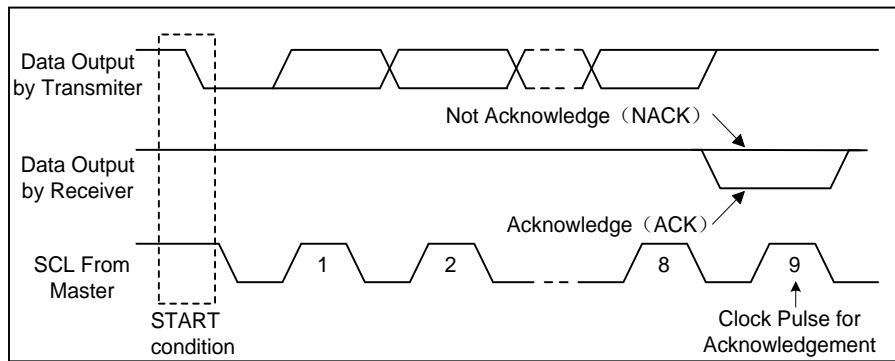

Figure 8 I<sup>2</sup>C ACK Timing

### 9.3.4 I<sup>2</sup>C Start/Stop

I2C start: SDA changes from high level to low level when SCL is high level.

I2C stop: SDA changes from low level to high level when SCL is high level.

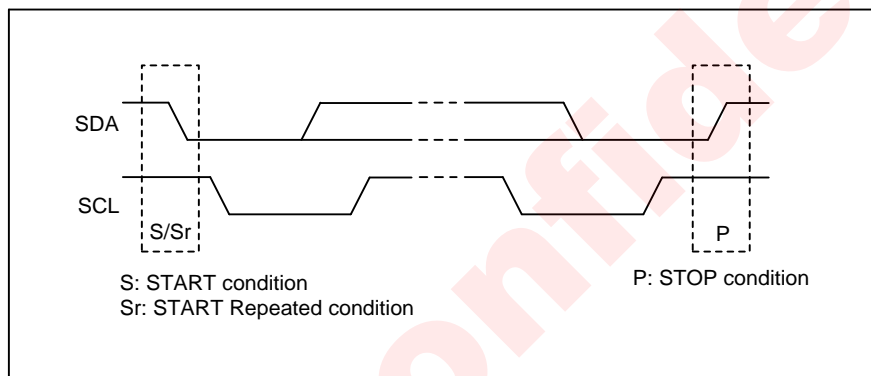

Figure 9 I<sup>2</sup>C Start/Stop Condition Timing

### 9.3.5 Write Cycle

One data bit is transferred during each clock pulse. Data is sampled during the high state of the serial clock (SCL). Consequently, throughout the clock's high period, the data should remain stable. Any changes on the SDA line during the high state of the SCL and in the middle of a transaction, aborts the current transaction. New data should be sent during the low SCL state. This protocol permits a single data line to transfer both command/control information and data using the synchronous serial clock.

Each data transaction is composed of a Start Condition, a number of byte transfers (set by the software) and a Stop Condition to terminate the transaction. Every byte written to the SDA bus must be 8 bits long and is transferred with the most significant bit first. After each byte, an Acknowledge signal must follow.

In a write process, the following steps should be followed:

- Master device generates START condition. The "START" signal is generated by lowering the SDA signal while the SCL signal is high.
- Master device sends slave address (7-bit) and the data direction bit ( $W = 0$ ).
- Slave device sends acknowledge signal if the slave address is correct.
- Master sends control register address (8-bit)
- Slave sends acknowledge signal
- Master sends data high 8Bit to be written to the addressed register
- Slave sends acknowledge signal

- h) Master sends data low 8Bit to be written to the addressed register
- i) Slave sends acknowledge signal
- j) Master generates STOP condition to indicate write cycle end

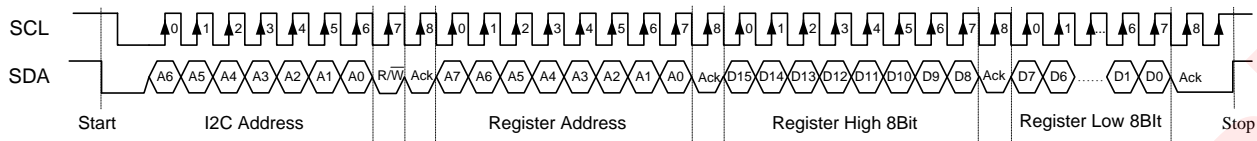

Figure 10 AW9203 I2C Write Timing

### 9.3.6 Read Cycle

In a read cycle, the following steps should be followed:

- a) Master device generates START condition
- b) Master device sends slave address (7-bit) and the data direction bit (W = 0).
- c) Slave device sends acknowledge signal if the slave address is correct.
- d) Master sends control register address (8-bit)
- e) Slave sends acknowledge signal
- f) Master generates STOP condition followed with START condition or REPEAT START condition
- g) Master device sends slave address (7-bit) and the data direction bit (R = 1).
- h) Slave device sends acknowledge signal if the slave address is correct.
- i) Slave sends data high 8Bit from addressed register.
- j) Master sends acknowledge signal
- k) Slave sends data low 8Bit from addressed register.
- l) If the master device sends acknowledge signal, the slave device will increase the control register address by one, then send the next data from the new addressed register. If master sends no acknowledge signal, the slave device stop to send data and wait for STOP condition.
- m) If the master device generates STOP condition, the read cycle is ended.

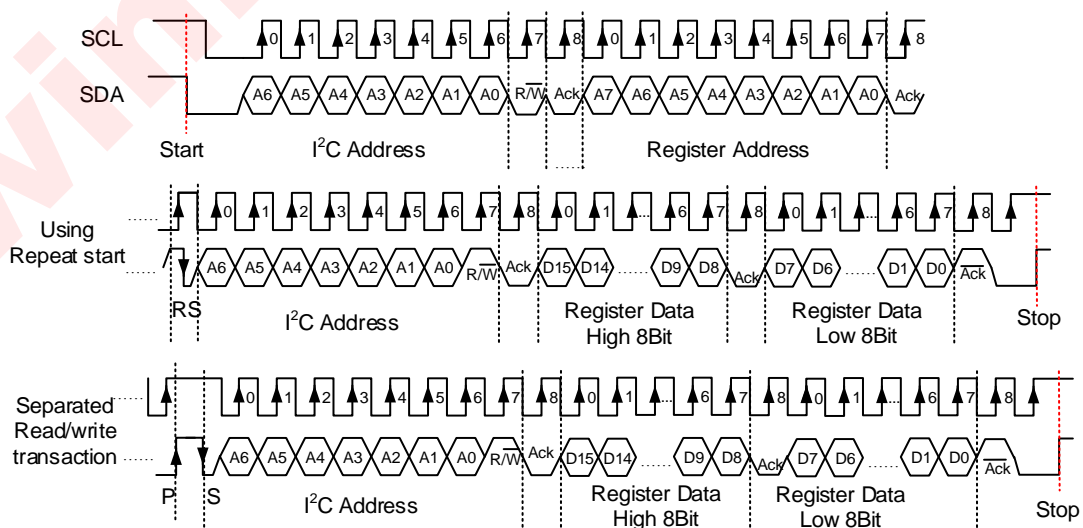

Figure 11 AW9203 I2C Read Timing

## 9.4 OSCILLATOR

An internal oscillator provides clock for both capacitive touch detecting circuit. If register bit GCR.SENE is high, the OSC starts to work, the start-up time is about 5  $\mu$ s. When the register bit GCR.SENE are low, the internal OSC stops.

## 9.5 CAPACITIVE TOUCH DETECTION

With high performance sigma-delta capacitive digital conversion technology, the capacitance on SX pin is measured, the finger touch decision is made according to the increment of SX capacitance. Before finger touching, the key capacitance is only formed by the sensing electrode and surrounding ground, which is called intrinsic capacitance usually. When finger touching, an additional parallel plate capacitor capacitance (electrode-media-finger) is formed, resulting in the capacitance increment on pin SX. In general, because of the variation of different electrode size and dielectric characteristic of different media materials, the capacitance increment caused by finger touch is about 0.5pF~5pF.

In AW9203, the CDC resolution is 12Bit. the sampling period can be set by control register. The capacitive sample are send to DSP for further processing, including digital filtering, base-line compensation, touch and gesture judge, and so on.

The capacitive sensitivity can be adjusted by REXT resistance. The bigger the REXT value, the higher the sensitivity. By default, 10k $\Omega$  to GND resistor is recommended.

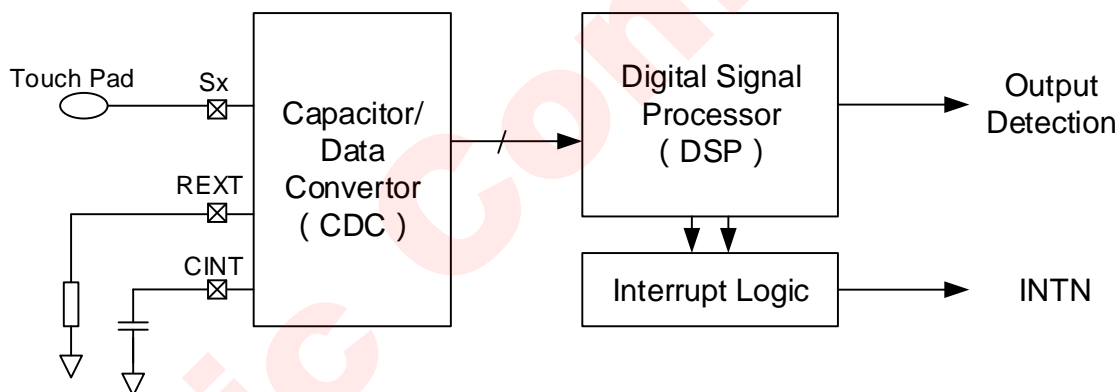

**Figure 12 Functional Block of Capacitive Detection Circuit**

When control bit GCR.SENE is 0, all capacitive touch detection circuit is reset. When control bit GCR.SENE is high, the SLPR register control the enable/disable touch detection. If control bit SLPR.SLPx is 0, channel x touch detection function is activated. If control bit SLPR.SLPx set to 1, channel x touch detection is disabled to save power consumption.

### 9.5.1 Touch Status and Interrupt

In AW9203 , the touch status can be read in register KEYST (0x31).

Touching status can generate the interrupt output on pin INTN, the interrupt enable control is defined by register KINTER (0x03). There are 4 interrupt mode selection defined by control bit KINTER.KIMD[1:0].

- KIMD[1:0] =00 interrupt generates when touch status changed
- KIMD[1:0] =01 interrupt generates when touch status changed from 1 to 0
- KIMD[1:0] =10 interrupt generates when touch status changed from 0 to 1
- KIMD[1:0] =11 interrupt generates when touch status is 1

The INTN pin will be pulled to GND when interrupt generates. The interrupt status can be clear by reading the register KISR (0x32) and INTN pin will be pulled up to  $V_{IO}$ .

### 9.5.2 Gesture Status

Besides for touch detection, AW9203 provides click gesture detection function, including slide gesture, single, double and triple click. Once the predefined gesture is detected, interrupt can be generated if corresponding interrupt enable bit is set in control register GIER. This function will help reduce programming on external MCU, and save the system power consumption, improve the usability.

The slide gesture detects the finger moving on the touchpad. When finger moves on the touchpad, the capacitive change can be detected one by one and the gesture module can identify the order of touch key and judge the slide gesture.

Register GSTR (0x20/0x21) defines the slide gesture.

15	14	13	12	11	10	9	8	7	6	5	4	3	2	1	0
0	KCODE1			0	KCODE2			0	KCODE3			0	0	0	0

KCODE1~3 define 3bit key code. The code can be 3(s1), 4(s2), 5(s3), 0(no key).

The tap gesture is somewhat like the click on touchpad or touch screen. When finger clicks on the touchpad quickly, the single, double or triple click can be recognized. The continuously, fast finger click on touch area will make the touch detection status switching between ON and OFF quickly. By analyzing the characteristic of ON and OFF, pre-defined tap gesture can be detected. In practice application, the double tap gesture is now widely used.

Register TAPR(0x27) defines the click gesture.

Register TAPR:

15	14	13	12	11	10	9	8	7	6	5	4	3	2	1	0
0	0	0	0	0	0	0	0	0	CSEL			0	0	TIMES	

TIMES defines the type of clicking, if TIMES =01, single click is enabled; if TIMES=10, double click is enabled; if TIMES=11, triple click is enabled, ,CSEL must set as 000001 for AW9203.

The register GIER(0x2D) can enable/disable interrupt triggered by detected click gesture. When defined click gesture is detected, the TIS bit in register GISR will be set, if the TIE bit in register GIER is set, interrupt will occur. The TIS bit will be clear after register GISR is read via I<sup>2</sup>C interface.

## 10 REGISTER DESCRIPTION

### 10.1 REGISTER CONFIGURATION

Address	Register	15	14	13	12	11	10	9	8	7	6	5	4	3	2	1	0
0x00	IDRST	D15	D14	D13	D12	D11	D10	D9	D8	D7	D6	D5	D4	D3	D2	D1	D0
0x01	GCR	0	0	0	0	0	0	0	0	0	0	0	0	0	0	0	0
0x02	SLPR	0	0	0	0	0	0	0	0	0	0	0	0	0	0	0	0
0x03	KINTER	0	0	0	0	0	0	0	KIMD		FRME	0	0	0	0	0	0
0x04	-	RESERVED															
0x05	-	RESERVED															
0x06	-	RESERVED															
0x07	AKSCR	0	0	0	0	0	0	0	0	0	0	0	0	0	0	0	0
0x08	SLSR	SLID_INTERVAL										TT	0	0	0	0	0
0x09	-	RESERVED															
0x0A	-	RESERVED															
0x0B	-	RESERVED															
0x0C	JDGTHR	CLRTH															
0x0D																	
0x0E																	
0x0F	-	RESERVED															
0x10	THR	0x08															
0x11	SCFG1	0	0	0	0	0	0	0	0	0	0	0	0	0	0	0	0
0x12	SCFG2	0	0	0	0	0	0	SEED			SCMD	0	NS	0	0	0	0
0x13	-	RESERVED															
0x14	OFSR1	0	0	0	EN2	OFFSET2			0	0	0	0	0	0	0	0	0
0x15	OFSR2	0	0	0	0	0	0	0	0	0	0	0	0	0	0	0	0
0x16	DOFCR1	DOF2				DOF1				0	0	0	0	0	0	0	0
0x17	DOFCR2																
0x18	IDLECR	INCR[7:0]										0	0	0	0	0	0
0x19	MTOTR	0															
0x1A	DISMAX	D15	D14	D13	D12	D11	D10	D9	D8	D7	D6	D5	D4	D3	D2	D1	D0
0x1B	SETCNT	CCNT															
0x1C	BLCTH	BLU															
0x1D	BLDTH	0	0	0	0	0	0	0	0	0	0	0	0	0	0	0	0
0x1E	MCR	0	0	0	0	0	0	0	0	0	0	0	0	0	0	0	0
0x1F	-	RESERVED															

Address	Register	15	14	13	12	11	10	9	8	7	6	
0x20	GDCFGR	0	0	0	0	0	0	GSTMD		AKST	AKSG	
0x21	GDTR	0	0	0	0	0	0	0	0			
0x22	TDTR	TONMAX										
0x23	GEST1	0	KEY1			0	KEY2			0		K
0x24	GEST2	0	KEY1			0	KEY2			0		K
0x25	-	RESERVED										
0x26	-	RESERVED										
0x27	TAPR	0	0	0	0	0	0	0	0	0	S3	
0x28	-	RESERVED										
-	-	RESERVED										
0x2C	-	RESERVED										
0x2D	GIE	0	0	0	0	0	0	0	0	0	0	
0x2E	GIS	0	0	0	0	0	0	0	0	0	0	
0x2F	GTIMR	0	0	0	0	0	0	0	0	0		
0x30	KISR	0	0	0	0	0	0	0	0	IDST	0	-
0x31	RAWST	0	0	0	0	0	0	0	0	0	0	
0x32	KEYST	0	0	0	0	0	0	0	0	0	SBI	0
0x33	-	RESERVED										
0x34	-	RESERVED										
0x35	SMOVCNT	0										
0x36	-	RESERVED										
0x37	-	RESERVED										
0x38	KDATA1	KDATA										
0x39	KDATA2	KDATA										
0x3A	KDATA3	KDATA										
0x3B	-	RESERVED										



## 10.2 GLOBAL REGISTER DESCRIPTION

### 10.2.1 IDRST, Chip ID and Software Reset

Address: 0x00, R/W															
15	14	13	12	11	10	9	8	7	6	5	4	3	2	1	0
D15	D14	D13	D12	D11	D10	D9	D8	D7	D6	D5	D4	D3	D2	D1	D0
Bit	Symbol		Description												
15:0	IDRST		Chip ID: 0xB223 Software Reset: write 0x55AA to IDRST, reset the whole device.												

### 10.2.2 GCR, Global Control Register

Address: 0x01, R/W, default: 0x0000																
15	14	13	12	11	10	9	8	7	6	5	4	3	2	1	0	
0	0	0	0	0	0	0	0	0	0	0	0	0	0	0	SENE	-
Bit	Symbol		Description													
1	SENE		Touch Key detection function 0: disable touch key detection (default) 1: enable touch key detection													

## 10.3 CAPACITIVE TOUCH DETECTION REGISTERS

### 10.3.1 SLPR, Sensor Sleep Control Register

Address: 0x02, R/W, default: 0x0000																
15	14	13	12	11	10	9	8	7	6	5	4	3	2	1	0	
0	0	0	0	0	0	0	0	0	0	0	0	SLP3	SLP2	SLP1	0	0
Bit	Symbol		Description													
4:2	SLP3~SLP1		Sensor sleep control 0: sensor work (default) 1: sensor sleep													

### 10.3.2 KINTER, Key Interrupt Enable Register

Address: 0x03, R/W, default: 0x0000															
15	14	13	12	11	10	9	8	7	6	5	4	3	2	1	0
0	0	0	0	0	0	KIMD		FRME	0	0	IE3	IE2	IE1	0	0
Bit	Symbol		Description												
4:2	IE3~1		Key Interrupt enable, pull INTN to GND when triggering interrupt. 0: disable interrupt (default) 1: enable interrupt												
5:6	-		Reserved, must be 0												
7	FRME		Sensor Scan Frame interrupt enable 0: disable frame interrupt (default) 1: enable frame interrupt												
9:8	KIMD		Interrupt mode 00: interrupt occurs when touch status changed (default) 01: interrupt occurs when touch status changed from 1 to 0 10: interrupt occurs when touch status changed from 0 to 1 11: interrupt occurs when touch status is 1												

### 10.3.3 AKSCR, Adjacent Key Suppression Configuration Register

Address: 0x07, R/W, default: 0x0000															
15	14	13	12	11	10	9	8	7	6	5	4	3	2	1	0
0	0	0	0	0	0	0	0	0	0	0	ASEL[3:1]			0	0
Bit	Symbol		Description												
4:2	ASEL		Adjacent Key Suppression Configuration, only one of ASEL=1 keys can be triggered.												

### 10.3.4 SLSR, Slide Configuration Register

Address: 0x08, R/W, default: 0x0200															
15	14	13	12	11	10	9	8	7	6	5	4	3	2	1	0
0	0	SLID_INTERVAL						TT	0	0	SLIDSEL			0	0
Bit	Symbol		Description												
4:3	SLIDSEL		Slide Configuration 0: Unused for slide configuration 1: Used for slide configuration												
6	-		Reserved, must be 0												
7	TT		Sliders coordinate detection mode 0: Not end to end mode 1: End to end mode												
13:8	SLD_INTERVAL		Key interval time of slider detection effective, T=SLIDINTVAL*Tscan(one frame cycle)												

### 10.3.5 JDGTHRn, key status judge configuration register

Address: 0x0C~0x0E, R/W, default: 0x080F															
15	14	13	12	11	10	9	8	7	6	5	4	3	2	1	0
CLRTH								SETTH							
Bit	Symbol		Description												
0:7	SETTH		Touch on threshold												
15:8	CLRTH		Touch off threshold												

### 10.3.6 NOISETHR, Noise Threshold Register

Address: 0x10, R/W, default: 0x080F															
15	14	13	12	11	10	9	8	7	6	5	4	3	2	1	0
0x08								NOISETH							
Bit	Symbol		Description												
7:0	NOISETH		Noise gate threshold (default value is 0x0F)												
15:8	-		Reserved												

### 10.3.7 SCFG1, Scan Configuration Register

Address: 0x11, R/W, default: 0x0004															
15	14	13	12	11	10	9	8	7	6	5	4	3	2	1	0
0	0	0	0	0	0	0	0	SCNMD	0	0	SCNUM				
Bit	Symbol		Description												
4:0	SCNUM		Scan cycle number, default value is 4. The bigger scan cycle number, the longer scan time, and the higher the detection sensitivity. SCNUM=0, 256 SCNUM!=0, SCNUM*512												
7	SCNMD		Scan mode 0: scan all keys, the cycle time is constant 1: scan the selected keys												
15~8	-		Reserved, must be 0												

### 10.3.8 SCFG2, Scan Configuration Register

Address: 0x12, R/W, default: 0x0107															
15	14	13	12	11	10	9	8	7	6	5	4	3	2	1	0
0	0	0	0	0	SEED			RFFLTEN		0	SENS				
Bit	Symbol		Description												
3:0	SENS		Sensitivity configuration, there are 16 level available. The less the value of SENS, the higher the sensitivity. 0000 is the highest sensitivity, 1111 is the lowest sensitivity, the default value is 0111.												
5:4	-		Reserved, must be 0												
7:6	RFFLTEN		RF filter enable, when enable RF filter, SCFG1.SCNUM should be bigger than 4. 00: RF filter off (default) 01: RF filter mode 1 enable 10: RF filter mode2 enable												

10:8	SEED	11: RF filter off ADC output data length selection 000: ADC/16 001: ADC/8 (default) 010: ADC/4 011: ADC/2 100: ADC/1
------	------	--

### 10.3.9 OFSR1, Key Capacitance Offset Register

Address: 0x14, R/W, default: 0x0000															
15	14	13	12	11	10	9	8	7	6	5	4	3	2	1	0
0	0	0	OFSEN2	OFFSET2				0	0	0	OFSEN1	OFFSET1			
Bit	Symbol		Description												
3:0	OFFSET1		S1 capacitance offset value												
4	OFSEN1		S1 capacitance offset enable												
7:5	-		Reserved, must be 0												
11:8	OFFSET2		S2 capacitance offset value												
12	OFSEN2		S2 capacitance offset enable												
15:13	-		Reserved, must be 0												

### 10.3.10 OFSR2, Key Capacitance Offset Register

Address: 0x15, R/W, default: 0x0000															
15	14	13	12	11	10	9	8	7	6	5	4	3	2	1	0
0	0	0	0	0	0	0	0	0	0	0	OFSEN3	OFFSET3			
Bit	Symbol		Description												
3:0	OFFSET3		S3 capacitance offset value												
4	OFSEN3		S3 capacitance offset enable												
7:5	-		Reserved, must be 0												
15:8	-		Reserved, must be 0												

### 10.3.11 DOFCR1-2, ADC Digital Offset Register

Address: 0x16, R/W, default: 0x0000															
15	14	13	12	11	10	9	8	7	6	5	4	3	2	1	0
DOF2				DOF1				-				DOF3			
Bit	Symbol		Description												
11:8	DOFx		digital offset of ADC data. Since the ADC is 12bit, if the key parasitic capacitance is large enough , ADC data will be more than 12 bit and overflow. The digital offset can compensate partly the ADC data within acceptable range by minus a setting value.												
15:12			0000 : offset= 0 (default)												
3:0			0001: offset = 2000												
			0010: offset = 4000												
			0011: offset = 6000												
			0100: offset = 8000												
			0101: offset = 10000												
			0110: offset = 12000												
			0111: offset = 14000												
			1xxx: not used												

### 10.3.12 IDLECR, IDLE Status Configuration Register

Address: 0x18, R/W, default: 0x1805															
15	14	13	12	11	10	9	8	7	6	5	4	3	2	1	0
INCR								0	IPER						
Bit	Symbol		Description												
6:0	IPER		Scan period setting in IDLE mode, default is 05H												

		Scan once every IPER normal scan periods
7	-	Reserved, must be 0
15:8	INCR	Time to enter IDLE mode, if no touch detected. The actual time can be calculated as : $T=INCR \cdot T_{SCAN} \cdot 16$ .

### 10.3.13 MTOTR, Maximum Touch On Time Register

Address: 0x19, R/W, default:0x0010															
15	14	13	12	11	10	9	8	7	6	5	4	3	2	1	0
0								MOT							
Bit	Symbol	Description													
7:0	MOT	Maximum time of keeping touch on status, $T= MOT \cdot T_{SCAN} \cdot 128$ $T_{SCAN}$ is capacitance touch key scanning cycle. $T_{SCAN} = Keys * SCNUM * 2us$													
15:8	-	Reserved, must be 0													

### 10.3.14 DISMAX, Maximum Margin of Valid Data

Address: 0x1A, R/W, default: 0x0040															
15	14	13	12	11	10	9	8	7	6	5	4	3	2	1	0
DISMAX															
Bit	Symbol	Description													
15:0	DISMAX	Maximum margin of valid data When the different of two consecutive raw data is larger than DISMAX, discard the raw data.													

### 10.3.15 SETCNT, Touch Decision De-bounce Count

Address: 0x1B, R/W, default: 0x0404															
15	14	13	12	11	10	9	8	7	6	5	4	3	2	1	0
CCNT								SCNT							
Bit	Symbol	Description													
7:0	SCNT	Touch on de-bounce threshold In no touch state, if delta over SETTHR for SCNT times continuously, touch status is set to 1.													
15:8	CCNT	Touch release de-bounce threshold In touch state, if delta below CLRTHR for CCNT times continuously, touch status is cleared.													

### 10.3.16 BLCTH, Baseline Trace Configuration Register

Address: 0x1C, R/W, default: 0x1008															
15	14	13	12	11	10	9	8	7	6	5	4	3	2	1	0
BLU								BLD							
Bit	Symbol	Description													
7:0	BLD	Baseline trace down speed, default value is 0x08 The bigger the BLD, the slower the trace down.													
15:8	BLU	Baseline trace up speed, default value is 0x10 The bigger the BLU, the slower the trace up.													

### 10.3.17 BLDTH, Baseline Reset Threshold

Address: 0x1D, R/W, default: 0x0000															
15	14	13	12	11	10	9	8	7	6	5	4	3	2	1	0
0								BLDTH							
Bit	Symbol	Description													
7:0	BLDTH	Baseline abnormal threshold. If raw data is less than the value of BLDTH, re-calibration of baseline will be activate. if BLDTH is 0x00, actual abnormal threshold is the same as SETTHR													
15:8	-	Reserved, must be 0													

### 10.3.18 MCR, Monitor Control Register

Address: 0x1E, R/W, default: 0x0000															
15	14	13	12	11	10	9	8	7	6	5	4	3	2	1	0
-	-	-	-	-	-	-	-	-	-	-	-	-	-	-	DSEL
Bit	Symbol	Description													
1:0	DSEL	KDATA register output data type selection in DEBUG mode 00: Normal mode , KDATA =0 (default) 01: delta data 10: baseline data 11: raw data													

### 10.3.19 GDCFG, Gesture Detection Configuration Register

Address: 0x20, R/W, default: 0x0000															
15	14	13	12	11	10	9	8	7	6	5	4	3	2	1	0
0	0	0	0	0	0	GSTMD		AKST	AKSG	0	S3	S2	S1	0	0
Bit	Symbol	Description													
5:0	S3~S1	Gesture detection channel choice 0: disable gesture detection 1: enable gesture detection													
6	AKSG	0: gesture detection without AKS key status 1: gesture detection with AKS key status													
7	AKST	0: tap detection without AKS key status 1: tap detection with AKS key status													
9:8	GSTMD	Gesture detection interrupt report mode 00: report after some time when finger leaving 01: report when finger leaving 1x: report when detecting gesture													

### 10.3.20 GDTR, Gesture Detection Time Register

Address: 0x21, R/W, default: 0x07																	
15	14	13	12	11	10	9	8	7	6	5	4	3	2	1	0		
0	0	0	0	0	0	0	0	GOFFMAX									
Bit	Symbol	Description															
7:0	GOFFMAX	Maximum touch off time of gesture detection When finger moves, the touching cannot be detected some times. The gesture ends when the time of touch off over $T_{OFFMAX}=GOFFMAX*T_{SCAN}$ .															

### 10.3.21 TDTR, Tap Detection Register

Address: 0x22, R/W, default: 0x080F															
15	14	13	12	11	10	9	8	7	6	5	4	3	2	1	0
TONMAX								TOFFMAX							
Bit	Symbol	Description													
15:8	TONMAX	Maximum touch on time of tap detection The tap is invalid when touch on time over $T_{ONMAX}=TONMAX*T_{SCAN}$ .													
7:0	TOFFMAX	Maximum touch off time of tap detection When finger taps, the touching cannot be off some times. The tap ends when the time of touch off over $T_{OFFMAX}=TOFFMAX*T_{SCAN}$ .													

### 10.3.22 GSTR1~2, Gesture Configuration Register

GSTR1: address: 0x23, R/W, default: 0x2340																
GSTR2: address: 0x24, R/W, default: 0x4320																
15	14	13	12	11	10	9	8	7	6	5	4	3	2	1	0	
0	KCODE1				0	KCODE2			0	KCODE3			0	0	0	0
Bit	Symbol	Description														
14:12	KCODE1	Gesture order of number 1 sensor channel 0: None 3: S1														

		4: S2 5: S3
10:8	KCODE2	Gesture order of number 2 sensor channel 0: None 3: S1 4: S2 5: S3
6:4	KCODE3	Gesture order of number 3 sensor channel 0: None 3: S1 4: S2 5: S3
3:0	-	Reserved, must be 0
<p>The sensor channel is touched one by one when finger moves. AW9203 judges the touch order is the predefined order or not. KCODE1 is the first touching sensor channel and then KCODE2/3 is detected. Every gesture configuration must be more than 2 sensor channel and the other is set to 0. The register is invalid if KCODE1 is 0.</p>		

### 10.3.23 TAPR, Tap Gesture Configuration Register

Address: 0x27, R/W, default: 0x12															
15	14	13	12	11	10	9	8	7	6	5	4	3	2	1	0
0	0	0	0	0	0	0	0	0		CSEL		0	0	TIMES	
Bit	Symbol		Description												
1:0	TIMES		Click times 1: single click 2: double click (default) 3: triple click												
6:4	CSEL		Tap sensor channel selection 0: disabled 1: enable												
15:8	-		Reserved, must be 0												

### 10.3.24 GIER, Gesture Interrupt Enable Register

Address: 0x2D, R/W, default: 0x0000															
15	14	13	12	11	10	9	8	7	6	5	4	3	2	1	0
0	0	0	0	0	0	0	0	0	0	0	0	TIE	0	0	GIE2 GIE1
Bit	Symbol		Description												
1:0	GIE2~1		Gesture detection interrupt 0: disable interrupt 1: enable interrupt												
4	TIE		Tap gesture detection interrupt enable 0: disable interrupt 1: enable interrupt												
15:5	-		Reserved, must be 0												

### 10.3.25 GISR, Gesture Interrupt Status Register

Address: 0x2E, R(cleared after reading), default: 0x0000															
15	14	13	12	11	10	9	8	7	6	5	4	3	2	1	0
0	0	0	0	0	0	0	0	0	0	0	0	TIS	0	0	GIS2 GIS1
Bit	Symbol		Description												
1:0	GIS2~1		Gesture detection interrupt status 0: no gesture interrupt 1: gesture interrupt												
4	TIS		Tap interrupt status 0: no tap interrupt 1: tap interrupt												
15:5	-		Reserved												

### 10.3.26 GTIMR, Gesture Duration Register

Address: 0x2F, R, default: 0x0000															
15	14	13	12	11	10	9	8	7	6	5	4	3	2	1	0
0	0	0	0	0	0	0	0	GTIMR							
Bit	Symbol	Description													
7:0	GTIMR	Gesture duration timer, from touch on to touch off $T_{GEST} = GTIMR * T_{SCAN}$ , 0: no limit													

### 10.3.27 RAWST, Raw Key Status Register

Address: 0x30, R, default: 0x0000															
15	14	13	12	11	10	9	8	7	6	5	4	3	2	1	0
0	0	0	0	0	0	0	IDLST	0	0	0	S3	S2	S1	0	0
Bit	Symbol	Description													
4:2	S3~1	Touch status 0: no touch 1: touch on													
8	IDLST	IDLE status indication 0: normal scan 1: IDLE mode status													

### 10.3.28 KEYST, AKS Key Status Register

Address: 0x31, R, default: 0x0000															
15	14	13	12	11	10	9	8	7	6	5	4	3	2	1	0
0	0	0	0	0	0	0	0	0	0	0	S3	S2	S1	0	0
Bit	Symbol	Description													
5:0	S3~1	AKS key status 0: no touch 1: touch on													

### 10.3.29 KISR, Key Interrupt Status Register

Address: 0x32, R(clear by reading), default: 0x0000															
15	14	13	12	11	10	9	8	7	6	5	4	3	2	1	0
0	0	0	0	0	0	0	0	SBI	-	-	IS3	IS2	IS1	-	-
Bit	Symbol	Description													
4:2	IS3~1	Key interrupt status 0: no key interrupt 1: key interrupt													
6	-	Reserved													
7	SBI	Set 1 every frame, clear by reading													

### 10.3.30 MOVCNTR, Slider Move Counter Register

Address: 0x35, R(clear by reading), default: 0x00															
15	14	13	12	11	10	9	8	7	6	5	4	3	2	1	0
0	0	0	0	0	0	0	0	MOVCNTR							
Bit	Symbol	Description													
7:0	MOVCNTR	Bit7 is sign bit, means the slide direction. Bit6-0 is the slide data.													

### 10.3.31 KDATAn, Key Data Register

Address: 0x38~0x3A, R, default: 0x0000															
15	14	13	12	11	10	9	8	7	6	5	4	3	2	1	0
KDATAn															
Bit	Symbol	Description													
15:0	KDATAn	Sn channel key data (refer register MCR(0x1E))													

**10.3.32 DUM0, Reserved Register**

Address: 0x3C, R/W, default: 0x0FFF															
15	14	13	12	11	10	9	8	7	6	5	4	3	2	1	0
DUM0															
Bit	Symbol	Description													
15:0	DUM0	Reserved register, default is 0x0FFF													

**10.3.33 DUM1, Reserved Register**

Address: 0x3D, R/W, default: 0x0FFF															
15	14	13	12	11	10	9	8	7	6	5	4	3	2	1	0
DUM1															
Bit	Symbol	Description													
15:0	DUM1	Reserved register, default is 0x0FFF													

awinic Confidential



## 11 TAPE AND REEL INFORMATION

### 11.1 Carrier Tape

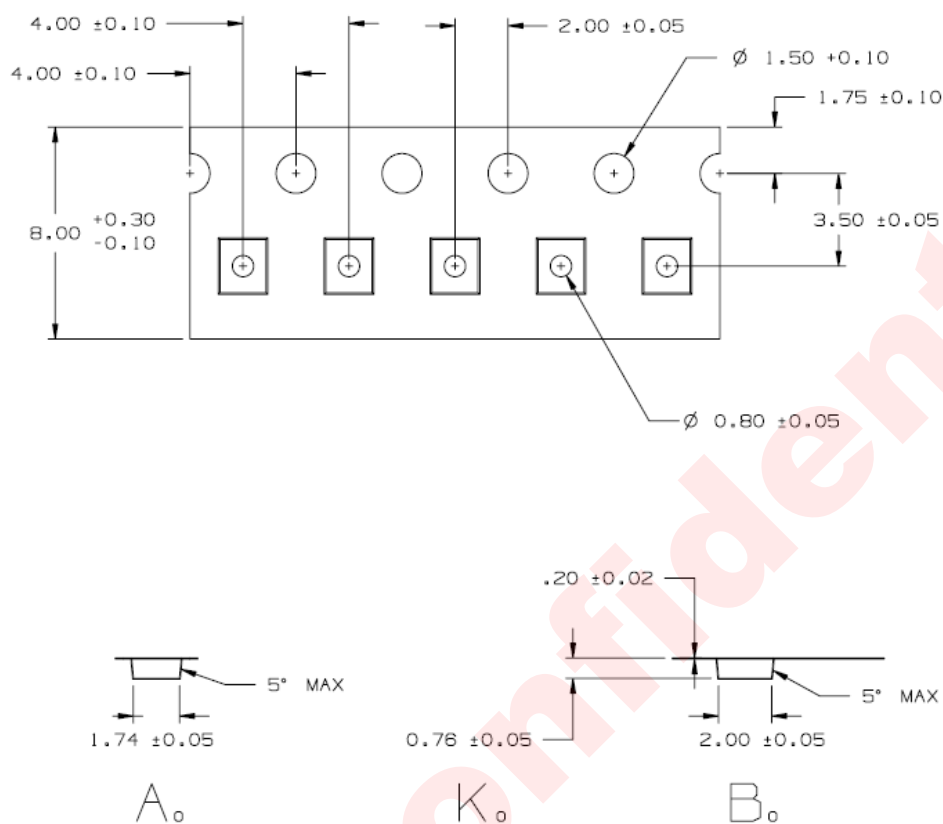

### 11.2 PIN1 Direction

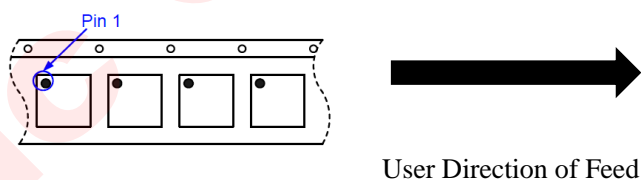

### 11.3 Reel

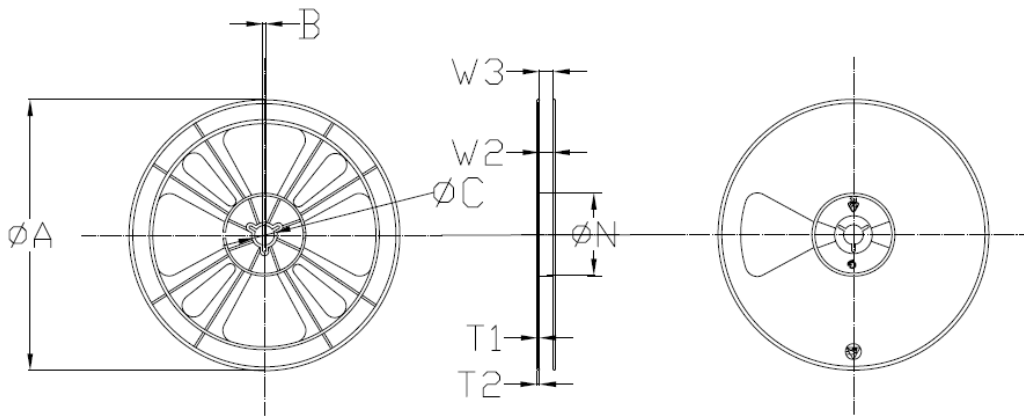

Item	Value&Tolerance
A	179±1.0
B	2.0±0.1
C	13.5±0.2
N	54.8±0.2
W2	9.0±0.2
W3	9.2±1.0
T1	1.2±0.2
T2	1.5±0.2

Note:

1. surface resistivity:  $10^5$  to  $10^{11}$  ohms/sq.
2. Restriction criterion of hazardous substance for packing material follow GP-M001.

## 12 PACKAGE DESCRIPTION

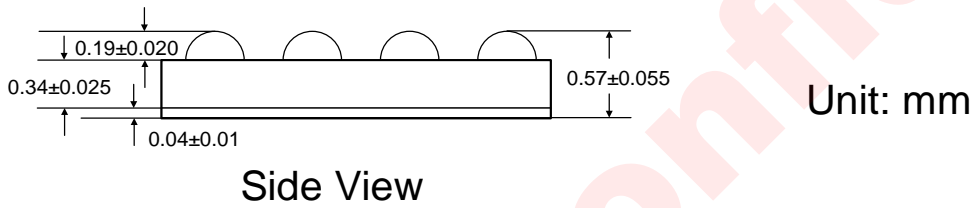
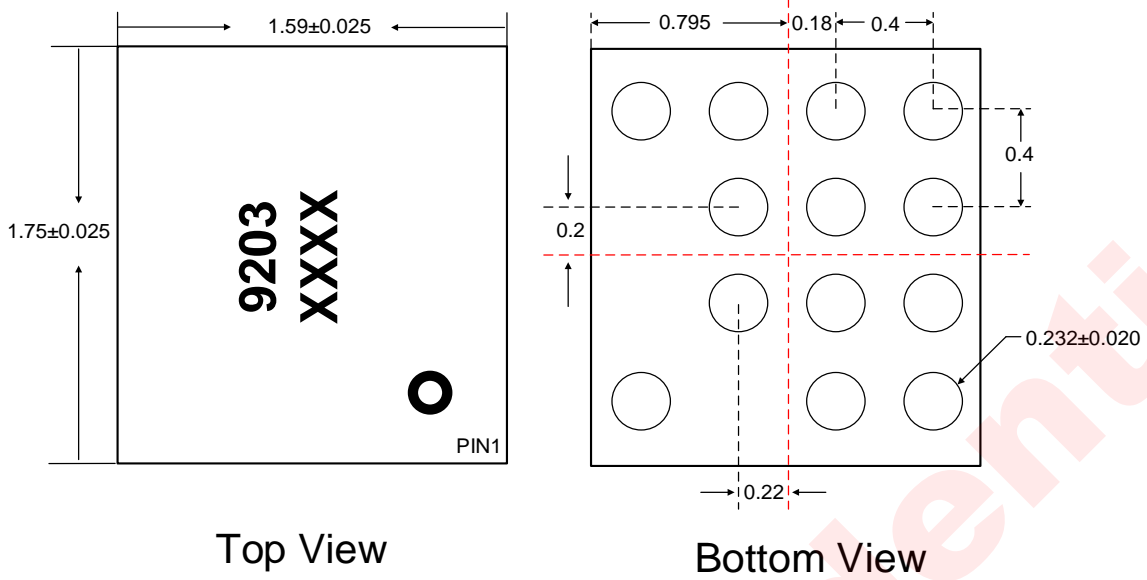

## 13 RECOMMENDED LAND PATTERN

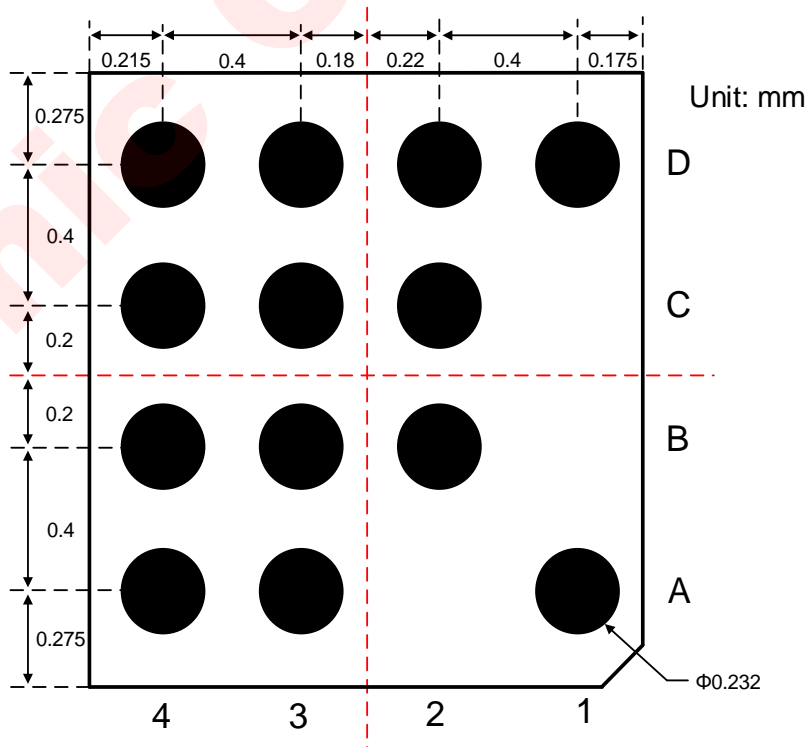

## 14 REFLOW

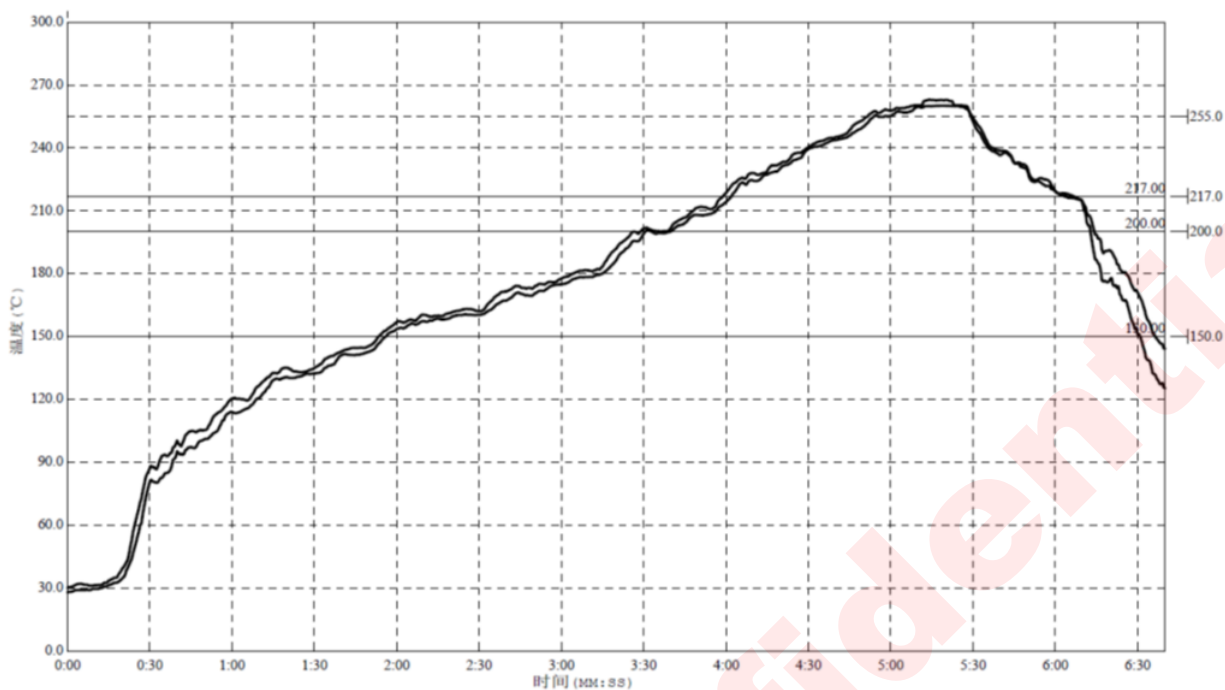

Reflow Note	Spec
Average ramp-up rate (217°C to peak)	Max. 3°C /sec
Time of Preheat temp. (from 150°C to 200°C)	60-120sec
Time to be maintained above 217°C	60-150sec
Peak Temperature	>260°C
Time within 5°C of actual peak temp	20-40sec
Ramp-down rate	Max. 6°C /sec
Time from 25°C to peak temp	Max. 8min

### Package Reflow Standard Profile

**NOTE 1:** All data are compared with the package-top temperature, measured on the package surface;

**NOTE 2:** AW9203 adopted the Pb-Free assembly.

## 15 REVISION HISTORY

Vision	Date	Change Record
V1.0	Nov 2016	Officially Released
V1.1	Nov. 2017	Remove the Chinese description Update the ordering information
V1.2	June 2018	Update reflow information Update ordering information
V1.3	Sep. 2018	Update the storage temperature
V1.4	Feb. 2019	Add power on procedure

awinic Confidential

## 16 DISCLAIMER

Information in this document is believed to be accurate and reliable. However, Shanghai AWINIC Technology Co., Ltd (AWINIC Technology) does not give any representations or warranties, expressed or implied, as to the accuracy or completeness of such information and shall have no liability for the consequences of use of such information.

AWINIC Technology reserves the right to make changes to information published in this document, including without limitation specifications and product descriptions, at any time and without notice. Customers shall obtain the latest relevant information before placing orders and shall verify that such information is current and complete. This document supersedes and replaces all information supplied prior to the publication hereof.

AWINIC Technology products are not designed, authorized or warranted to be suitable for use in medical, military, aircraft, space or life support equipment, nor in applications where failure or malfunction of an AWINIC Technology product can reasonably be expected to result in personal injury, death or severe property or environmental damage. AWINIC Technology accepts no liability for inclusion and/or use of AWINIC Technology products in such equipment or applications and therefore such inclusion and/or use is at the customer's own risk.

Applications that are described herein for any of these products are for illustrative purposes only. AWINIC Technology makes no representation or warranty that such applications will be suitable for the specified use without further testing or modification.

All products are sold subject to the general terms and conditions of commercial sale supplied at the time of order acknowledgement.

Nothing in this document may be interpreted or construed as an offer to sell products that is open for acceptance or the grant, conveyance or implication of any license under any copyrights, patents or other industrial or intellectual property rights.

Reproduction of AWINIC information in AWINIC data books or data sheets is permissible only if reproduction is without alteration and is accompanied by all associated warranties, conditions, limitations, and notices. AWINIC is not responsible or liable for such altered documentation. Information of third parties may be subject to additional restrictions.

Resale of AWINIC components or services with statements different from or beyond the parameters stated by AWINIC for that component or service voids all express and any implied warranties for the associated AWINIC component or service and is an unfair and deceptive business practice. AWINIC is not responsible or liable for any such statements.

## X-ON Electronics

Largest Supplier of Electrical and Electronic Components

*Click to view similar products for [Touch Screen Controllers](#) category:*

*Click to view products by [Awinic](#) manufacturer:*

Other Similar products are found below :

[CY8CTMA1036AS-33](#) [CY8CTMA461AA-33](#) [ATMXT1664T3-C2U](#) [CY8CTMA460AS-33](#) [CY8CTMA768AS-33](#) [ATMXT1716EEGV-Z2U](#)  
[ATMXT224-MAH](#) [CG8526AA](#) [FTCU04C](#) [CP8667AT](#) [CP7598AT](#) [SIM535A99-R55ALL-25](#) [AW9203CSR](#) [TSC2301IPAG](#) [LDS6124NQGI](#)  
[AR1021-I/ML](#) [BU21025GUL-E2](#) [TSC2046EQPWRQ1](#) [SX8652IWLTRT](#) [AT42QT1011-TSHR](#) [AR1021-IML](#) [AR1011-I/SO](#) [AR1100T-I/SS](#)  
[BU21026MUV-E2](#) [BU21029MUV-E2](#) [ADS7846N/2K5](#) [AR1100T-I/SO](#) [CYAT81652-100AA48](#) [AR1021T-I/ML](#) [TS01S](#) [TS02NT](#) [TS04](#)  
[TSM12M](#) [AD7873ARUZ-REEL7](#) [AD7843ARQZ](#) [AD7843ARQZ-REEL7](#) [AD7843ARUZ](#) [AD7843ARUZ-REEL7](#) [AD7873ACPZ](#)  
[AD7873ARQZ](#) [AD7873ARUZ](#) [AD7873BRQZ](#) [AD7877ACPZ-500RL7](#) [AD7879-1ACPZ-500R7](#) [AD7879-1WARUZ-RL7](#) [AD7877ACPZ-](#)  
[REEL7](#) [AD7879WARUZ-RL7](#) [APT8L08SE](#) [AT42QT1050-MMHR](#) [HX612D](#)