

4-Channel 1-wire Dimming LED Driver with Ultra Low Dropout Current Source

FEATURES

- Ultra low dropout: 50mV/20mA(typical)
- Support up to 4 LEDs
- LED sink current up to 20mA
- $\pm 1\%$ LED current matching(typical)
- En Pin Deglitch circuit
- Thermal shutdown protection
- 16-step brightness control
- ESD protection: $\pm 8\text{kV}$ (HBM)
- No EMI and switch noise
- Packages: DFN2x2-8L

APPLICATIONS

- Mobile phone
- Digital camera
- PDA MP3

DESCRIPTION

The AW9364 is a 4-channel ultra low dropout constant-source parallel LED driver. With the proprietary Q-Mirror™ technique, the AW9364 uses an internal resistor to set the bias current for four LEDs, which are matched to $\pm 1\%$. The AW9364 incorporates a single wire interface to program the output current at 16 continuous steps. The AW9364 has an internal deglitch circuit for filtering the noise of the EN input. The AW9364 requires only a 40mV dropout voltage at a 20mA load. The feature makes AW9364 ideal for battery-operated systems, such as personal digital assistants.

The AW9364 is available in DFN2x2-8L packages and is specified over the -40°C to $+85^{\circ}\text{C}$ temperature range.

PIN CONFIGURATION AND MARKING

AW9364DNR TOP VIEW
(DFN2x2-8L)

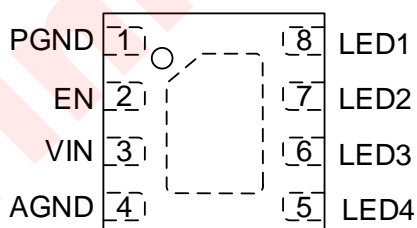

AW9364DNR MARKING
(DFN2x2-8L)

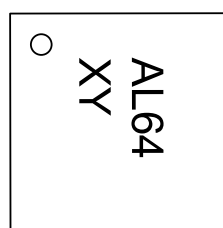

AL64 - AW9364DNR

XY - Production Tracing Code

Figure 1 Pin Configuration of AW9364

TYPICAL APPLICATION CIRCUITS

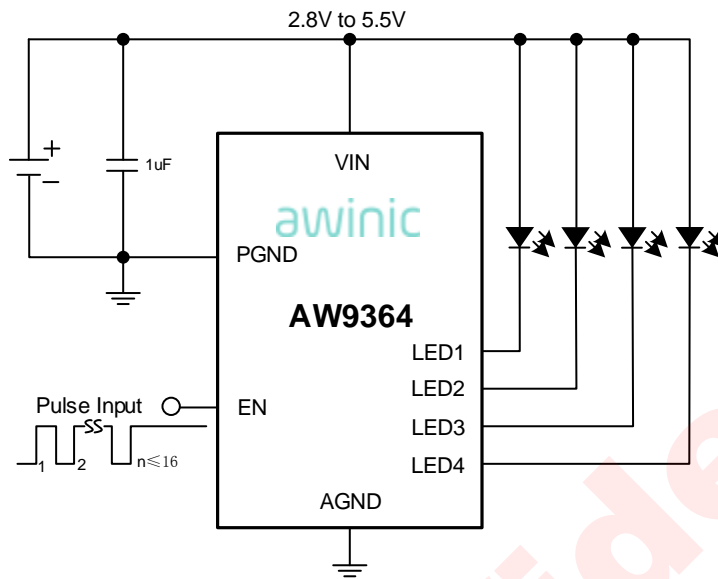

Figure 2 AW9364 Typical Application

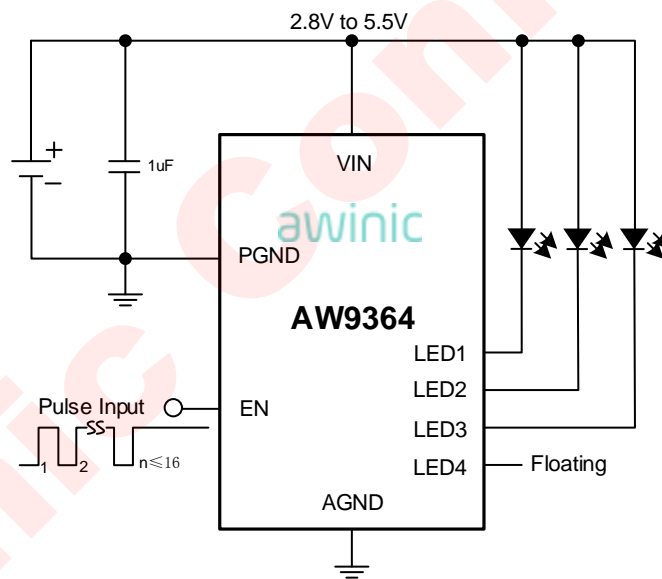

Figure 3 3-LED Application

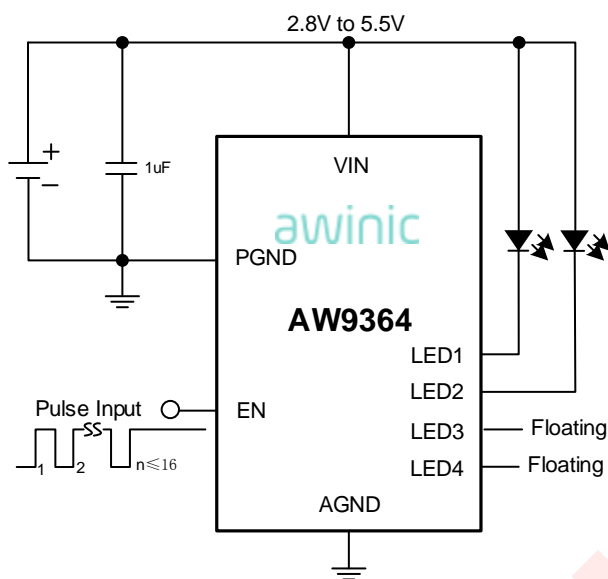

Figure 4 2-LED Application

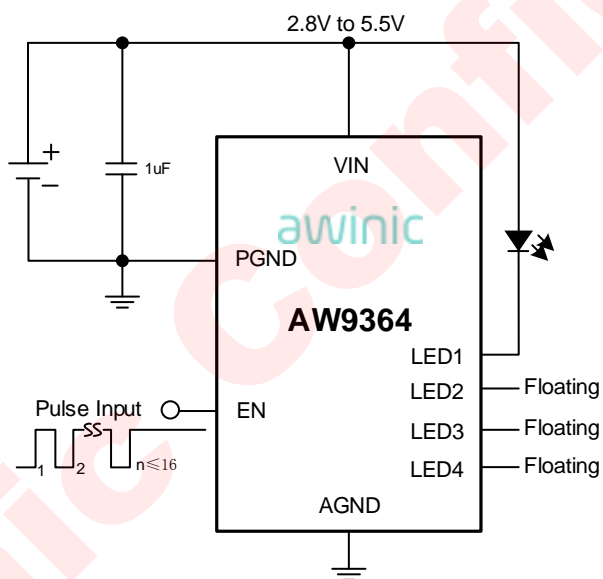
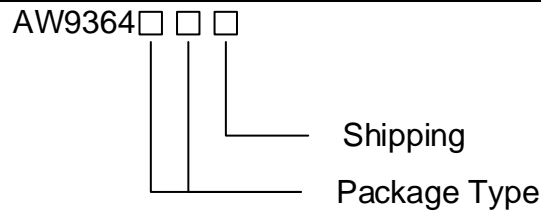

Figure 5 1-LED Application

ORDERING INFORMATION

Order Number	Temperature Range	Package	Marking	Moisture sensitivity level	Environmental Information	Packing Type
AW9364DNR	-40°C ~ 85°C	DFN2x2-8L	AL64	MSL3	RoHS+HF	3000 units/Tape and Reel



Package Type	Shipping
DN:DFN2x2-8L	R:Tape & Reel

ABSOLUTE MAXIMUM RATINGS⁽¹⁾

Parameter	Range
Supply Voltage VDD	-0.3V to 6 V
Input Voltage EN	-0.3V to 6 V
Power Dissipation, (P _D @ T _A =25°C)	0.44 W
Maximum Junction Temperature	125°C
Storage Temperature Range	-65°C to 150°C
Lead Temperature (Soldering 10 Seconds)	260°C
Package Thermal Resistance θ_{JA}	76°C/W
ESD Rating ⁽²⁾	
Human Body Model	±8000 V
Latch-up ⁽³⁾	
Latch-up current maximum rating per JEDEC standard	+IT:450mA -IT:-450mA

ELECTRICAL CHARACTERISTICS

Test Condition: $T_A=25^{\circ}\text{C}$, $V_{IN}=3.6\text{V}$, $C_{IN} = 1\mu\text{F}$ (unless otherwise specified)

Parameter	Symbol	Condition	Min	Typ.	Max	Units
Supply Voltage	V_{IN}		2.8		5.5	V
Output Current	I_{LED}	All LEDs 100% setting	16.5	20	23.5	mA
Current Matching		All LEDs 100% setting	-5		5	%
LED Dropout Voltage	V_{DO}	$I_{LED}=20\text{mA}$		50	170	mV
Quiescent Current	I_Q	$I_{LED}=0$		330		μA
Shutdown Current	I_{SD}	$V_{EN}=0\text{V}$, $V_{IN}=5.5\text{V}$		0.1	1	μA
Startup Time	T_{ON}			20		μs
Enable High Level Input Voltage	V_{IH}		1.5			V
Enable Low Level Input Voltage	V_{IL}				0.3	V
EN Low Time for Dimming	T_{LO}		0.5		500	μs
EN High Time for Dimming	T_{HI}		0.5			μs
Shutdown Delay Time	T_{OFF}	$V_{EN}=0\text{V}$	800		2500	μs
Thermal Shutdown Temperature	T_P			145		$^{\circ}\text{C}$
Hysteresis Temperature				20		$^{\circ}\text{C}$

NOTE1: Stresses beyond those listed under "absolute maximum ratings" may cause permanent damage to the device. These are stress ratings only and functional operation of the device at these or any other conditions beyond those indicated under "recommended operating conditions" is not implied. Exposure to absolute-maximum-rated conditions for extended periods may affect device reliability.

NOTE2: The human body model is a 100pF capacitor discharged through a 1.5k Ω resistor into each pin.

NOTE3: Test condition: JEDEC STANDARD NO.78A FEBRUARY 2006.

PIN DEFINITION

PIN	Symbol	Description
4	AGND	Analog Ground
1	PGND	Power Ground
3	VIN	Supply Input
2	EN	Enable Pin. Active high, with an internal 150kΩ pull-down resistor.
5	LED4	LED4 Pin, Connect to the LED cathode, leave it to connect GND or open if unused.
6	LED3	LED3 Pin, Connect to the LED cathode, leave it to connect GND or open if unused.
7	LED2	LED2 Pin, Connect to the LED cathode, leave it to connect GND or open if unused.
8	LED1	LED1 Pin, Connect to the LED cathode, leave it to connect GND or open if unused.
9	GND	Exposed pad, should be connected to gnd.

TYPICAL OPERATION CHARACTERISTICS

Test condition: $T_A=25^{\circ}\text{C}$, $V_{IN}=3.6\text{V}$, $C_{IN}=1\mu\text{F}$ unless otherwise specified.

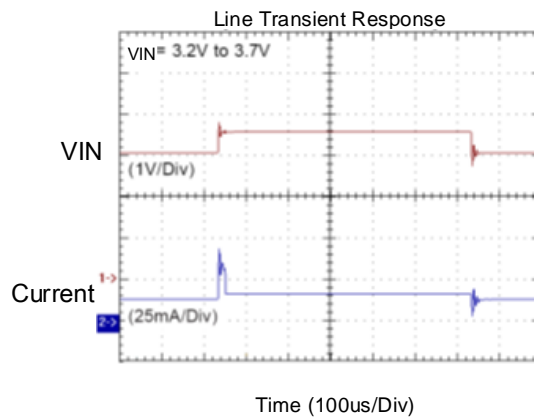
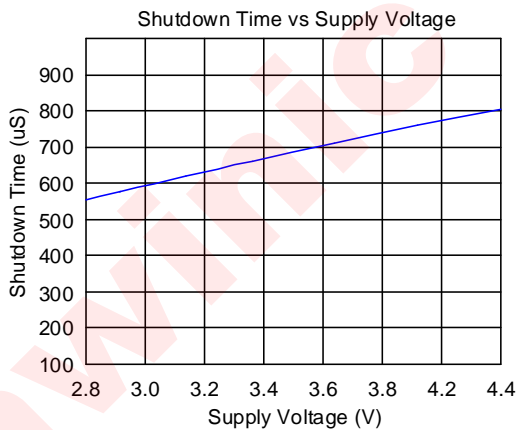
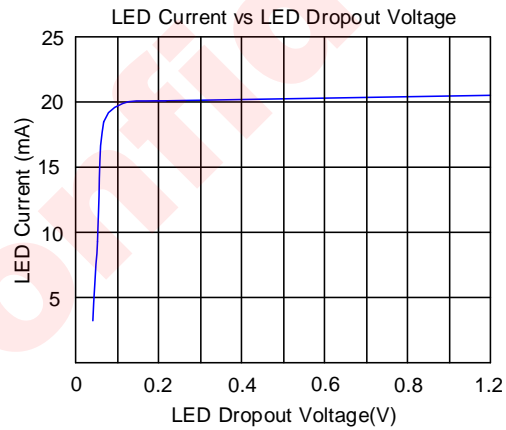
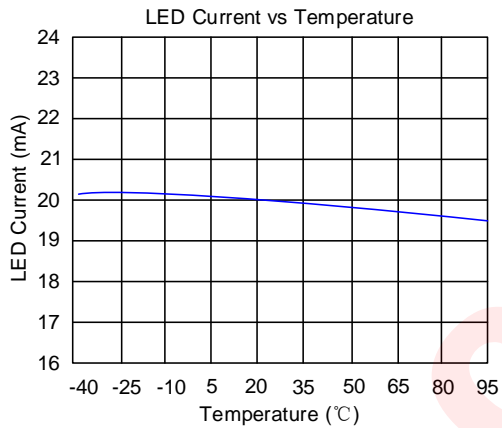
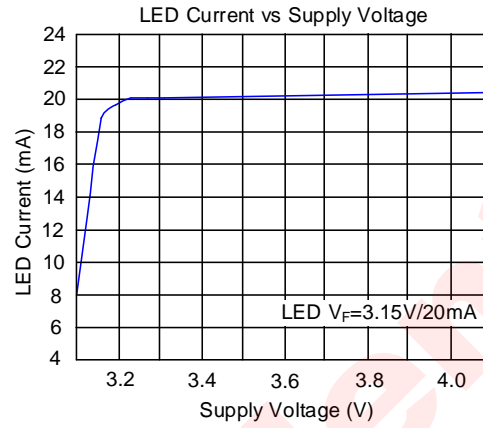
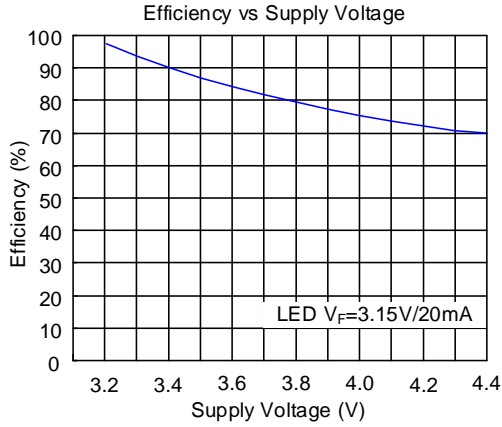

BLOCK DIAGRAM

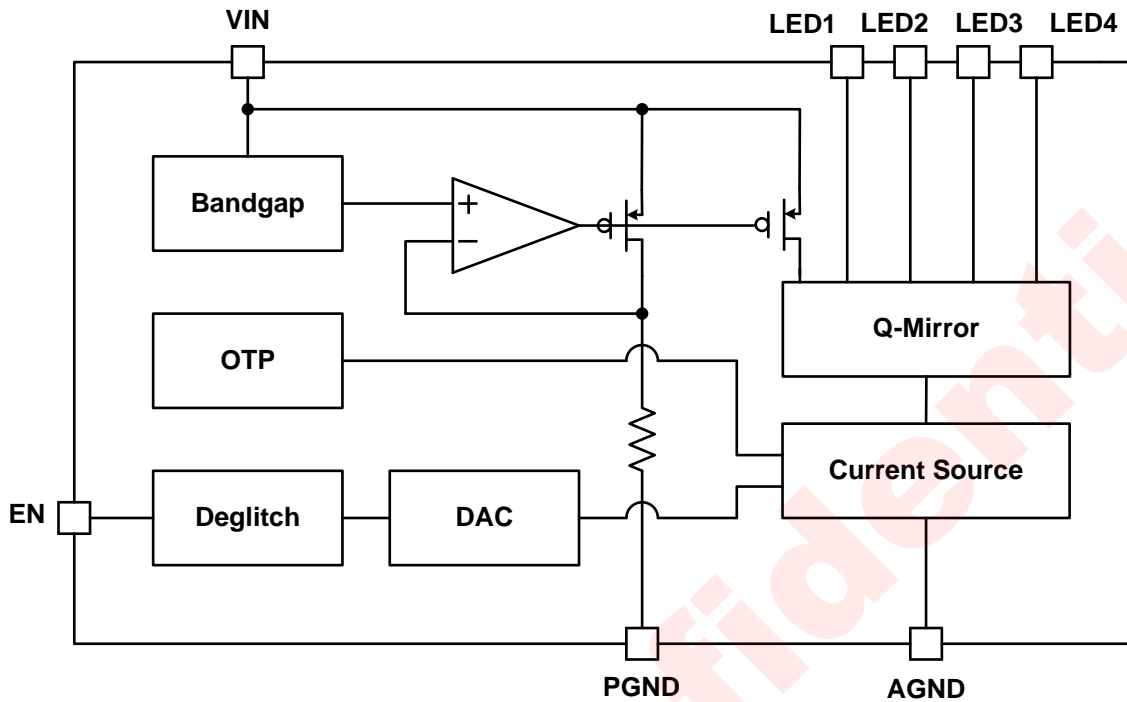

Figure 6 Functional Block Diagram of AW9364

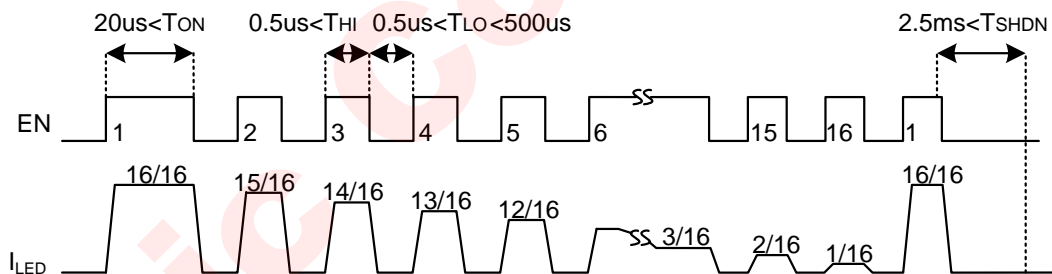

Figure 7 16-steps brightness control of AW9364

DETAILED DESCRIPTION

The AW9364 is a high efficiency, no noise LED driver which powering up to 4-channel LED's at 20mA. Figure 2 shows a typical application circuit for four LEDs. In order to maintain LED constant current, the input voltage must provide the required LED forward voltage and current source dropout voltage. The AW9364 requires only 40mV dropout voltage at a 20mA load on each output to match the LED brightness.

Enable Input

The EN input is used to enable or disable the AW9364. Pulling the EN pin higher than 1.5V will enable the device. For producing constant, non-pulsating output current compare to conventional pulse width modulation (PWM) dimming scheme, the AW9364 incorporates a 4-bit DAC for brightness control to program the output current at 16 continuous steps: 20~1.25mA. Table 1 shows detail for current setting.

Table 1 Current Setting

EN Rise Edge Number	Current (mA)	EN Rise Edge Number	Current (mA)
1	20	9	10
2	18.75	10	8.75
3	17.5	11	7.5
4	16.25	12	6.25
5	15	13	5
6	13.75	14	3.75
7	12.5	15	2.5
8	11.25	16	1.25

The figure 7 shows the detail operation of 16-steps brightness control. When 1-wire pulse counting dimming is used, the ready time is recommended to be greater than 20 μ s for enabling the device, the pulse high time T_{HI} recommended to be greater than 0.5 μ s, and the pulse low time T_{LO} is recommended to be greater than 0.5 μ s and less than 500 μ s. A constant current is sourced as long as the EN signal remains high. The shutdown feature reduces quiescent current to less than 0.1 μ A.

Deglintch Circuit

The AW9364 has an internal deglitch circuit for filtering the noise of the EN input. For example, the EN pin is sometimes superimposed with noise, or a so-called glitch, and the glitch may be greater than the enable high level input voltage V_{IH} . In such a case, the deglitch circuit is used as a filter circuit for removing the glitch.

Over Thermal Protection

The AW9364 has an internal over thermal protection circuit. The over temperature circuit will turn off the output current to decrease the power dissipation when the junction temperature exceeds 145 $^{\circ}$ C and will resume the output circuit when the junction temperature falls below 125 $^{\circ}$ C

Efficiency

The AW9364 offers superior efficiency performance. Due to the ultra low-dropout current sinks and direct connection to the supply, higher average efficiency and higher peak efficiency is obtained.

The system efficiency, defined as the ratio between the LED's power and the input power can be calculated simply as the following:

$$\text{Efficiency} = (V_{F1} \times I_{LED1} + V_{F2} \times I_{LED2} + V_{F3} \times I_{LED3} + V_{F4} \times I_{LED4}) / (V_{IN} \times I_{IN})$$

V_F is the LED forward voltage, $V_{IN} = V_F + V_{DO}$, V_{DO} is the dropout voltage needed in the current source.

awinic Confidential

TAPE AND REEL INFORMATION

CARRIER TAPE

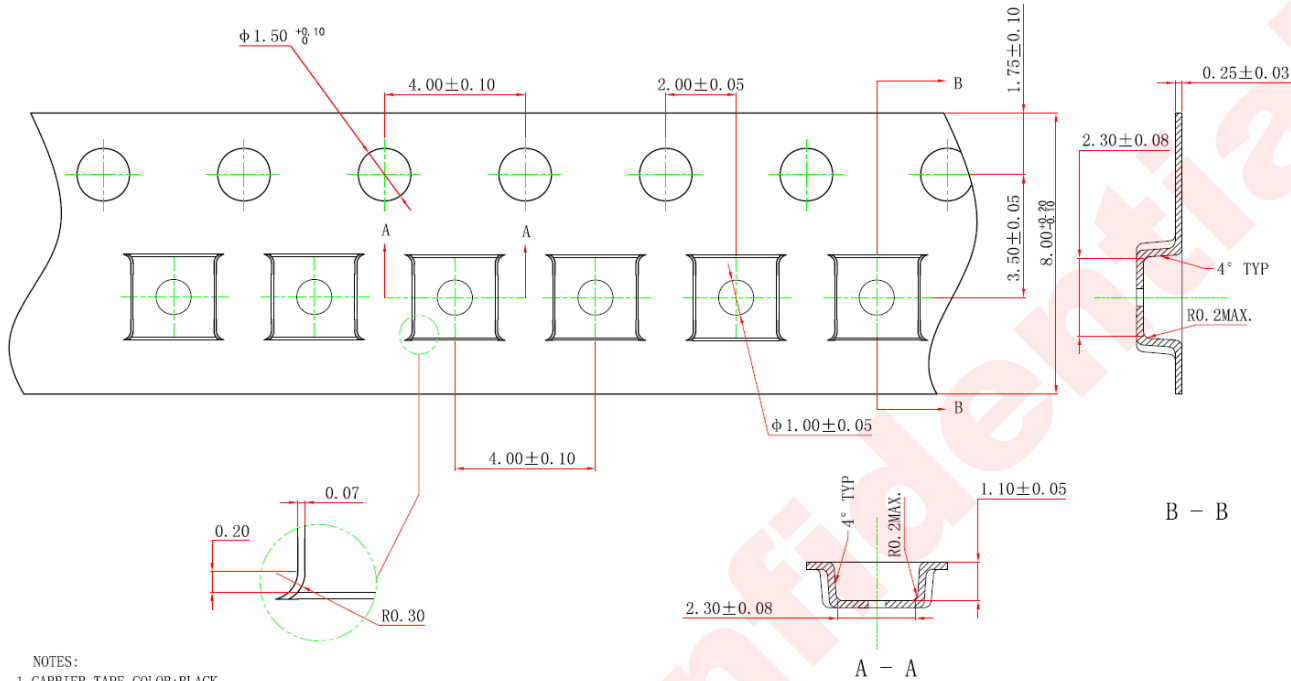

NOTES:

1. CARRIER TAPE COLOR:BLACK
2. COVER TAPE WIDTH: 5.5 ± 0.10
3. COVER TAPE COLOR:TRANSPARENT
4. 10 SPROCKET HOLE PITCH CUMULATIVE TOLERANCE $\pm 0.10MAX.$
5. CAMBER NOT TO EXCEED 1 MM IN 100 MM
6. MOLD: MISWB/DFNWB/QFNWB2 $\times 2 \times 0.75/0.85$
7. ALL DIMS IN mm.

PIN1

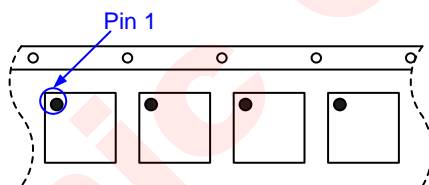

User Direction of Feed

REEL

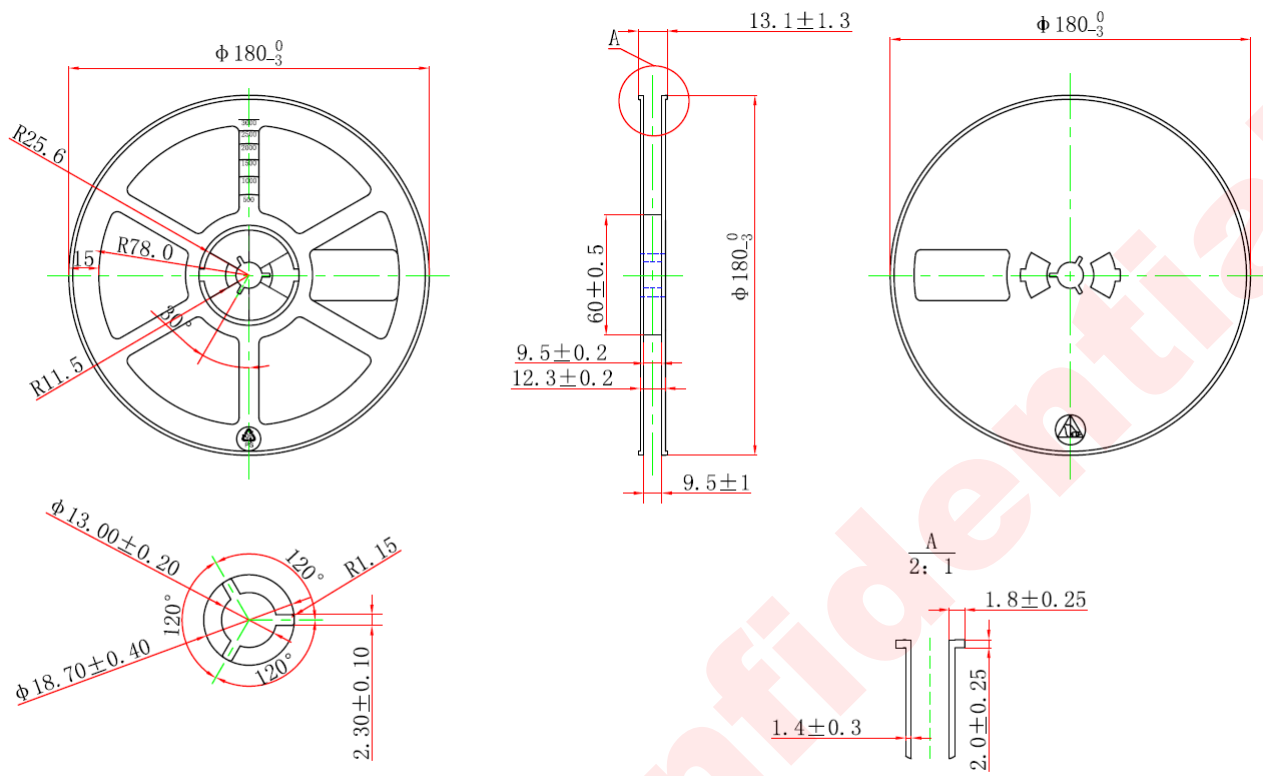

- NOTES:
1. COLOR: BLUE
2. ALL DIM IN mm
5. GENERAL TOLERANCE ± 0.25 ;

PACKAGE DESCRIPTION

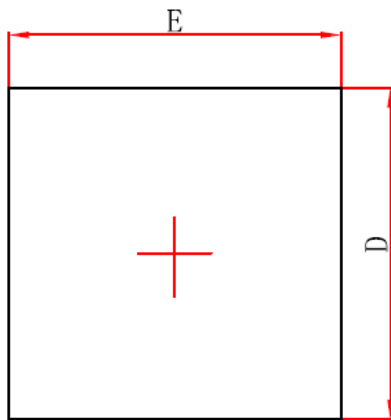

Top View

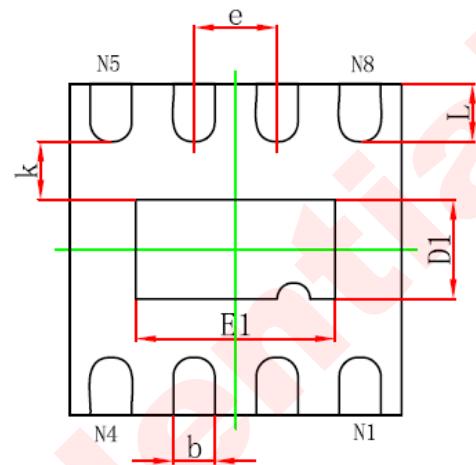

Bottom View

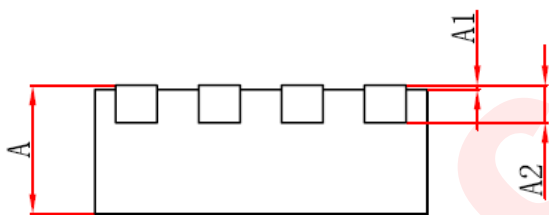

Side View

Unit:mm	DFN-8L		
Symbol	Min	Typ	Max
A	0.700	0.750	0.800
A1	0.000		0.050
A2	0.203(Ref.)		
b	0.180	0.240	0.300
D1	0.500	0.600	0.700
D	1.900	2.000	2.100
L	0.250	0.350	0.450
k	0.200 (MIN.)		
e	0.500 (BSC)		
E	1.900	2.000	2.100
E1	1.100	1.200	1.300

REFLOW

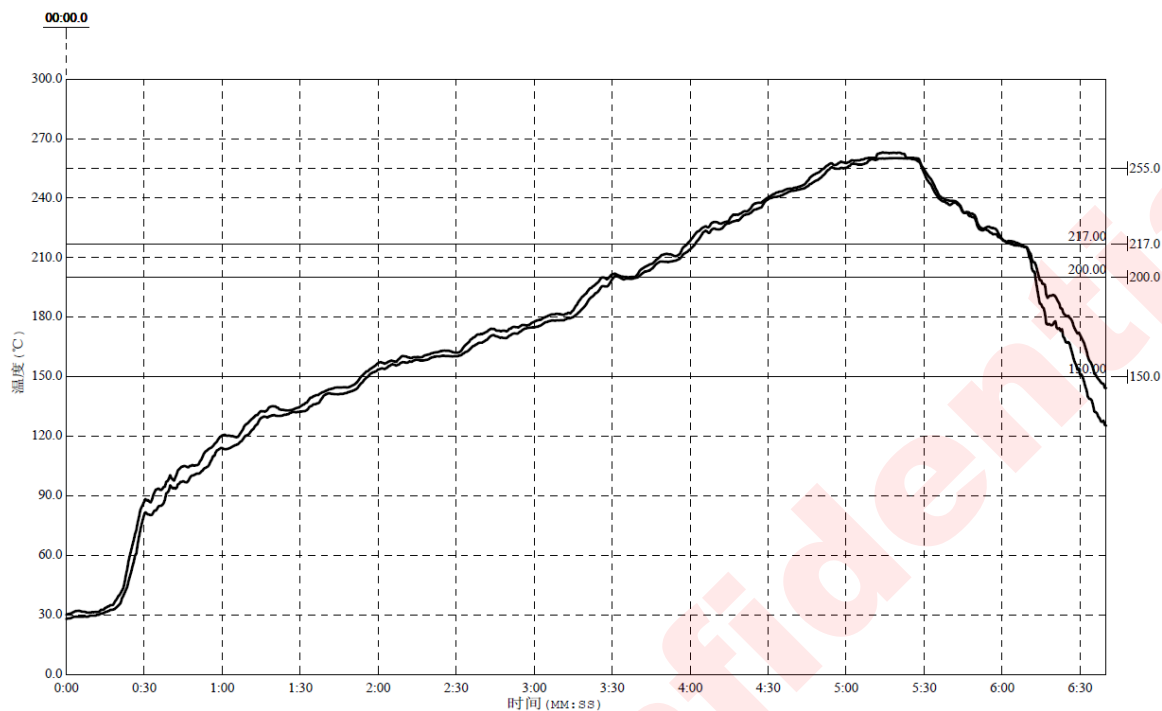

Figure 8 Package Reflow Oven Thermal Profile

Reflow Note	Spec
Average ramp-up rate (217°C to Peak)	Max. 3°C/sec
Time of Preheat temp.(from 150°C to 200°C)	60-120sec
Time to be maintained above 217°C	60-150sec
Peak Temperature	250°C-260°C
Time within 5°C of actual peak temp	20-40sec.
Ramp-down rate	Max. 6°C/sec
Time from 25°C to peak temp	Max. 8min.

REVISION HISTORY

Date	Vision	Description
2017-4-12	V1.7	-
2018-1-9	V2.2	1. Refreshed documental format; 2. Updated some characteristics information.
2018-2-28	V2.3	1. Added Carrier Tape and Pin1 information; 2. Added Reflow information; 3. Updated Land Pattern example; 4. Updated Package Description.

awinic Confidential

DISCLAIMER

Information in this document is believed to be accurate and reliable. However, Shanghai AWINIC Technology Co., Ltd (AWINIC Technology) does not give any representations or warranties, expressed or implied, as to the accuracy or completeness of such information and shall have no liability for the consequences of use of such information.

AWINIC Technology reserves the right to make changes to information published in this document, including without limitation specifications and product descriptions, at any time and without notice. Customers shall obtain the latest relevant information before placing orders and shall verify that such information is current and complete. This document supersedes and replaces all information supplied prior to the publication hereof.

AWINIC Technology products are not designed, authorized or warranted to be suitable for use in medical, military, aircraft, space or life support equipment, nor in applications where failure or malfunction of an AWINIC Technology product can reasonably be expected to result in personal injury, death or severe property or environmental damage. AWINIC Technology accepts no liability for inclusion and/or use of AWINIC Technology products in such equipment or applications and therefore such inclusion and/or use is at the customer's own risk.

Applications that are described herein for any of these products are for illustrative purposes only. AWINIC Technology makes no representation or warranty that such applications will be suitable for the specified use without further testing or modification.

All products are sold subject to the general terms and conditions of commercial sale supplied at the time of order acknowledgement.

Nothing in this document may be interpreted or construed as an offer to sell products that is open for acceptance or the grant, conveyance or implication of any license under any copyrights, patents or other industrial or intellectual property rights.

Reproduction of AWINIC information in AWINIC data books or data sheets is permissible only if reproduction is without alteration and is accompanied by all associated warranties, conditions, limitations, and notices. AWINIC is not responsible or liable for such altered documentation. Information of third parties may be subject to additional restrictions.

Resale of AWINIC components or services with statements different from or beyond the parameters stated by AWINIC for that component or service voids all express and any implied warranties for the associated AWINIC component or service and is an unfair and deceptive business practice. AWINIC is not responsible or liable for any such statements.

X-ON Electronics

Largest Supplier of Electrical and Electronic Components

Click to view similar products for [LED Display Drivers](#) category:

Click to view products by [Awinic](#) manufacturer:

Other Similar products are found below :

[MAP9000QNRH](#) [AP5726WUG-7](#) [AL8806QMP-13](#) [AP5726FDCG-7](#) [AS3693B-ZTQT](#) [AP5725WUG-7](#) [MAX139EQH+D](#) [STP16DP05PTR](#)
[STP16CPP05PTR](#) [STP16CPP05XTTR](#) [LV5236VZ-TLM-H](#) [BP9911CC](#) [ZXLD1366QEN8TC](#) [MT7725D](#) [TX6143](#) [SY6813PEC](#) [SD1002L4](#)
[AW3643CSR](#) [MP3370GN-Z](#) [LA2284L-G09-T](#) [SEDA](#) [SCT2027CSSG](#) [LYT3315D](#) [LYT3324D](#) [LYT4211E2](#) [LYT4214E2](#) [LYT4215E2](#)
[LYT4217E2](#) [LYT4218E2](#) [LYT4222E](#) [LYT4317E2](#) [LYT4321E](#) [LYT4323E](#) [LYT4324E3](#) [LYT4326E3](#) [TPS92020DR](#) [TPS92691PWPR](#)
[BCR420U](#) [HV9801ALG-G](#) [IS31FL3199-QFLS2-TR](#) [IS31FL3731-QFLS2-TR](#) [CAT4238TD](#) [SCT2001ASIG](#) [SCT2024CSSG](#) [SCT2024CSTG](#)
[SCT2167CSOG](#) [SCT2167CSSG](#) [STP16CPPS05XTTR](#) [TLE4241GMFUMA1](#) [ICM7212MIQH+D](#)