

1A Low Dropout Linear Regulator

❖ GENERAL DESCRIPTION

AX1117A is a low dropout positive adjustable or fixed-mode regulator with minimum of 1A output current capability. The product is specifically designed to provide well-regulated supply for low voltage IC applications such as high-speed bus termination and low current 3.3V logic supply. AX1117A is also well suited for other applications such as VGA cards. AX1117A is guaranteed to have lower than 1.4V dropout at full load current making it ideal to provide well-regulated outputs of 1.25 to 5.0 with 6.4V to 12V input supply.

❖ FEATURES

- 1.5V maximum dropout at full load current
- Fast transient response
- Output current limiting
- Built-in thermal shutdown
- Good noise rejection
- Low-ESR Ceramic Capacitor (MLCC) Required for Stability.
- 3-Terminal Adjustable or Fixed 1.5V, 1.8V, 2.5V, 3.3V, 5.0V
- Packages: SOT223, TO252.

❖ BLOCK DIAGRAM

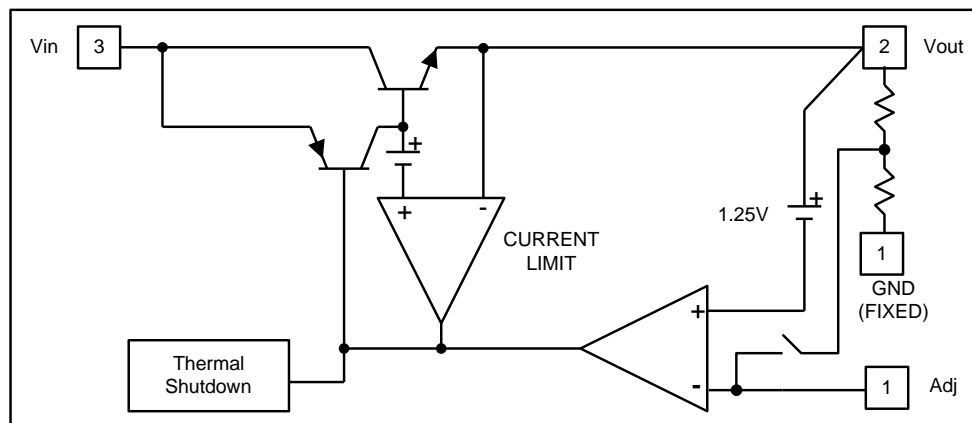

❖ PIN ASSIGNMENT

The packages of AX1117A are SOT223 and TO252; the pin assignment is given by:

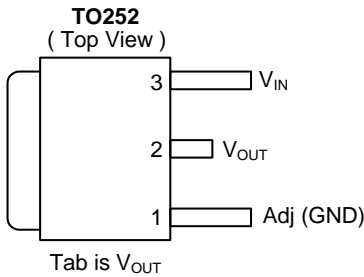
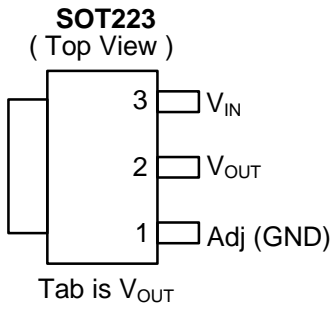

Name	Description
Adj (GND)	A resistor divider from this pin to the V _{OUT} pin and ground sets the output voltage. (Ground only for Fixed-Mode)
V _{OUT}	The output of the regulator. A minimum of 3.3uF EL capacitor (10mΩ ≤ ESR ≤ 1Ω) must be connected from this pin to ground to insure stability. (Note)
V _{IN}	The input pin of regulator. Typically a large storage capacitor is connected from this pin to ground to insure that the input voltage does not sag below the minimum dropout voltage during the load transient response. This pin must always be 1.5V higher than V _{OUT} in order for the device to regulate properly. (Note)

Note: To prevent oscillation, a 4.7uF minimum Y5V or a 1uF minimum X7R or X5R dielectric is strongly recommended if ceramics are used as input/output capacitors.

❖ ORDER/MARKING INFORMATION

Order Information	
<p>AX 1117A X XX X</p> <pre> graph TD Root[AX 1117A X XX X] --> L1[Low Dropout Regulator] Root --> L2[Package] Root --> L3[VOUT] Root --> L4[Packing] </pre> <p>E : SOT223-3L Blank : ADJ Blank : Tube D : TO252-3L 15 : 1.5V A : Taping 18 : 1.8V 25 : 2.5V 33 : 3.3V 50 : 5.0V</p>	
Top Marking (SOT223-3L)	Top Marking (TO252-3L)
<p>ADJ</p> <p>Logo ← AX 1 1 1 7 → Part number A → Functional code Y W W X → ID code: internal → WW: 01~52 → Year: A=2010 1=2011 2=2012 ⋮ 9=2019</p> <p>FIX</p> <p>Output Voltage ← AX 1 1 1 7 A - V V AX1117A-15: 1.5V AX1117A-18: 1.8V AX1117A-25: 2.5V AX1117A-33: 3.3V AX1117A-50: 5.0V</p> <p>Y W W X → ID code: internal → WW: 01~52 → Year: A=2010 1=2011 2=2012 ⋮ 9=2019</p>	<p>ADJ</p> <p>Logo ← AX 1 1 1 7 → Part number A → Functional code Y Y W W X → ID code: internal → WW: 01~52 → Year: A=2010 1=2011 2=2012 ⋮ 9=2019</p> <p>FIX</p> <p>Output Voltage ← AX 1 1 1 7 A - V V AX1117A-15: 1.5V AX1117A-18: 1.8V AX1117A-25: 2.5V AX1117A-33: 3.3V AX1117A-50: 5.0V</p> <p>Y Y W W X → ID code: internal → WW: 01~52 → Year: A=2010 1=2011 2=2012 ⋮ 9=2019</p>

❖ ABSOLUTE MAXIMUM RATINGS

Parameter	Symbol	Rating	Unit
DC Supply Voltage	V _{in}	-0.3 to 15	V
Operating Junction Temperature Range	T _{OP}	-40 to +125	°C
Maximum junction Temperature	T _{MJ}	150	°C
Power Dissipation(No heat sink ;No air flow) T _A =25°C, T _J =125°C	SOT-223	850	mW
	TO-252	1050	
Storage Temperature	T _{ST}	-65 to +150	°C

❖ ELECTRICAL CHARACTERISTICS

 (T_A=25°C, Under Operating Conditions)

Characteristics	Conditions	Min	Typ	Max	Units
Operation Input Voltage		2.75	-	12	V
Reference Voltage	AX1117A-ADJ T _J =25°C, (V _{IN-OUT}) =1.5V I _{OUT} =10mA	1.225	1.250	1.275	V
Output Voltage	AX1117A-1.5 I _{OUT} = 10mA, T _J = 25°C, 3V ≤ V _{IN} ≤ 12V	1.470	1.500	1.530	V
	AX1117A-1.8 I _{OUT} = 10mA, T _J = 25°C, 3.3V ≤ V _{IN} ≤ 12V	1.764	1.800	1.836	V
	AX1117A-2.5 I _{OUT} = 10mA, T _J = 25°C, 4V ≤ V _{IN} ≤ 12V	2.450	2.500	2.550	V
	AX1117A-3.3 I _{OUT} = 10mA, T _J = 25°C, 4.8V ≤ V _{IN} ≤ 12V	3.235	3.300	3.365	V
	AX1117A-5.0 I _{OUT} = 10mA, T _J = 25°C, 6.5V ≤ V _{IN} ≤ 12V	4.900	5.000	5.100	V
Line Regulation	AX1117A-XXX I _{OUT} =10mA, V _{OUT} +1.5V<V _{IN} <12V, T _J =25°C (Note 1,2)	-	0.2	0.5	%
Load Regulation	AX1117A-ADJ V _{IN} =3.3V, V _{adj} =10mA< I _{OUT} <1A, T _J =25°C (Note 1,2)	-	0.4	1	%
	AX1117A-1.5 V _{IN} =3V, 10mA< I _{OUT} <1A, T _J =25°C (Note 1,2)	-	12	15	mV
	AX1117A-1.8 V _{IN} =3.3V, 10mA< I _{OUT} <1A, T _J =25°C (Note 1,2)	-	15	18	mV

	AX1117A-2.5	$V_{IN}=4V, 10mA < I_{OUT} < 1A,$ $T_J=25^{\circ}C$ (Note 1,2)	-	20	25	mV
	AX1117A-3.3	$V_{IN} = 5V, 10mA \leq I_{OUT} \leq 1A,$ $T_J=25^{\circ}C$ (Note 1,2)	-	26	33	mV
	AX1117A-5.0	$V_{IN} = 6.5V, 10mA \leq I_{OUT} \leq 1A,$ $T_J=25^{\circ}C$ (Note 1,2)	-	40	50	mV
Dropout Voltage ($V_{IN}-V_{OUT}$)	AX1117A-ADJ /1.5/1.8/2.5/3.3/5.0	$I_{OUT} = 1A, \Delta V_{OUT}=1\%V_{OUT}$	-	1.3	1.5	V
Current Limit	AX1117A-ADJ /1.5/1.8/2.5/3.3/5.0	$(V_{IN}-V_{OUT}) = 3V$	1.1	-	-	A
Minimum Load Current	AX1117A-XXX	$0^{\circ}C \leq T_J \leq 125^{\circ}C$	-	5	7	mA
Ripple Rejection	F=120Hz, $C_{OUT}=10\mu f, 4.7\mu f, 3.3\mu f$					
	AX1117A-XXX	$V_{IN}=V_{OUT}+3V$	50	60	70	dB
Temperature Stability	$I_{OUT} = 10mA$		-	0.5	-	%
θ_{JA} Thermal Resistance Junction-to-Ambient (No heat sink ;No air flow)	SOT-223 TO-252		-	117 92	-	$^{\circ}C/W$
θ_{JC} Thermal Resistance Junction-to-Case	SOT-223 TO-252		-	15 10	-	$^{\circ}C/W$

Note1: See thermal regulation specifications for changes in output voltage due to heating effects. Line and load regulation are measured at a constant junction temperature by low duty cycle pulse testing. Load regulation is measured at the output lead = 1/18" from the package.

Note2: Line and load regulation are guaranteed up to the maximum power dissipation of 15W. Power dissipation is determined by the difference between input and output differential and the output current. Guaranteed maximum power dissipation will not be available over the full input/output range.

Note3: Quiescent current is defined as the minimum output current required in maintaining regulation. At 12V input/output differential the device is guaranteed to regulate if the output current is greater than 10mA.

❖ APPLICATION CIRCUIT

(1) Using Multilayer Ceramic Capacitor (MLCC)
Fixed Output

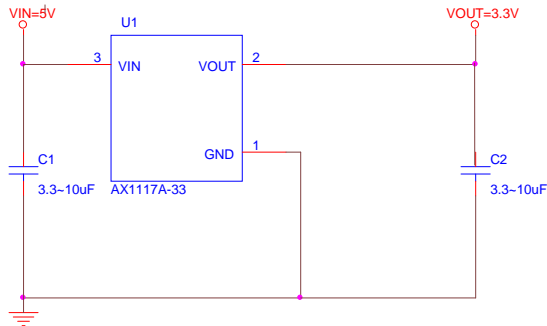

ADJ Output

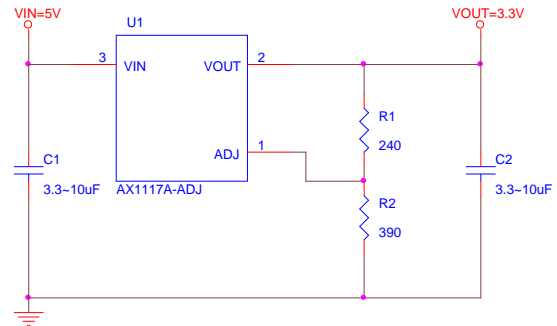

$$V_{OUT} = V_{REF} \times \left(1 + \frac{R2}{R1}\right); V_{REF} = 1.250V$$

(2) Using Aluminum Electrolytic Capacitor (AL)

Fixed Output

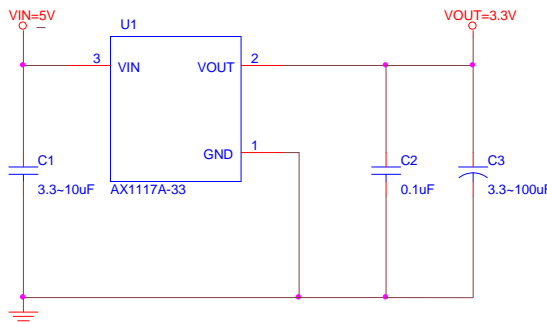

ADJ Output

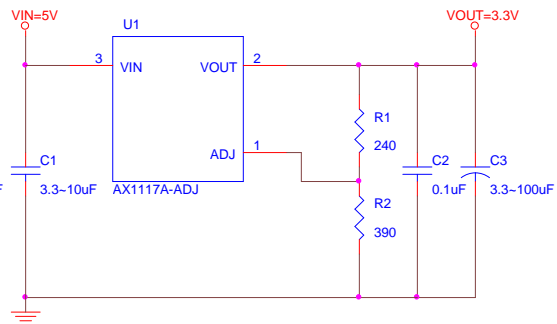

$$V_{OUT} = V_{REF} \times \left(1 + \frac{R2}{R1}\right); V_{REF} = 1.250V$$

❖ TYPICAL CHARACTERISTICS

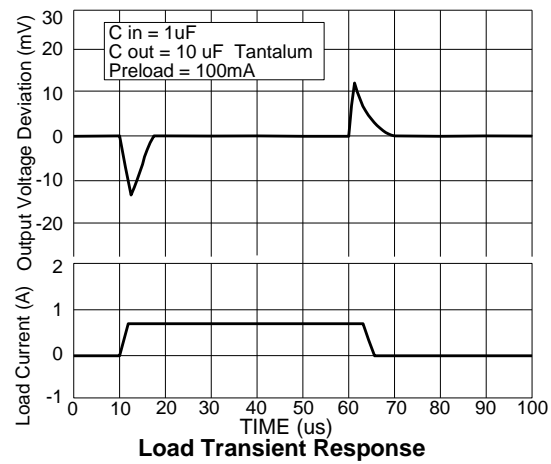
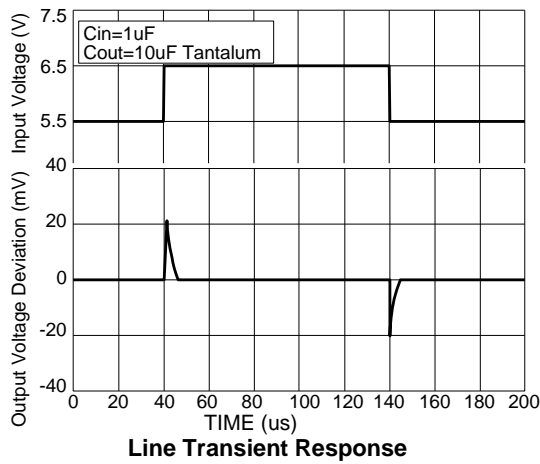
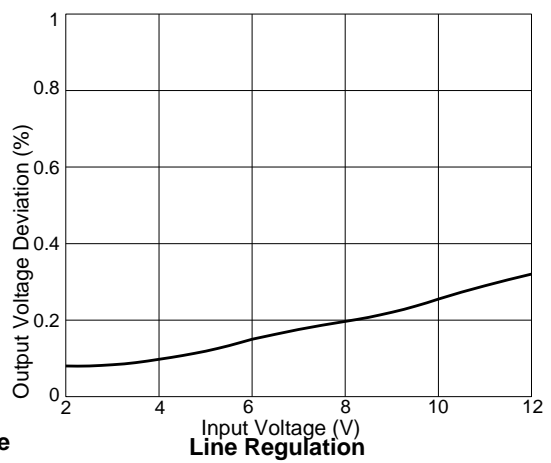
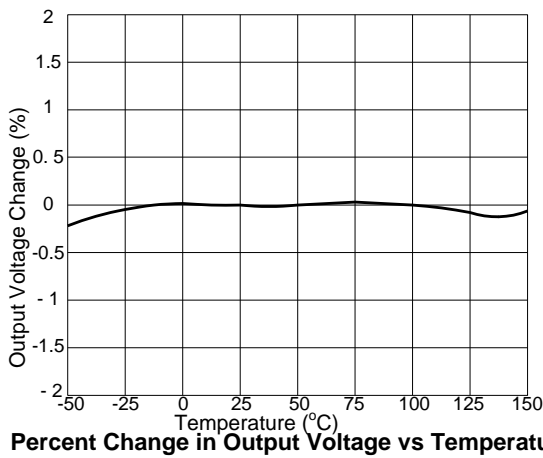
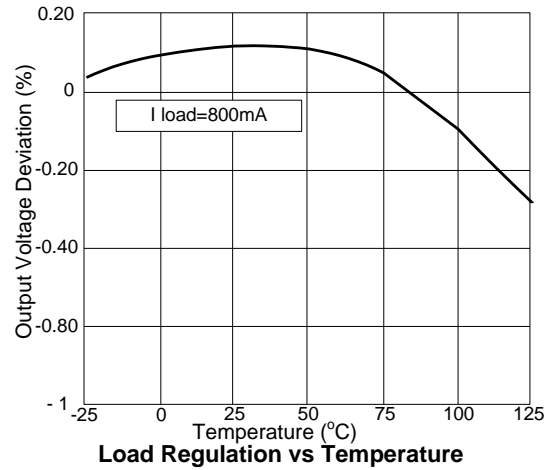
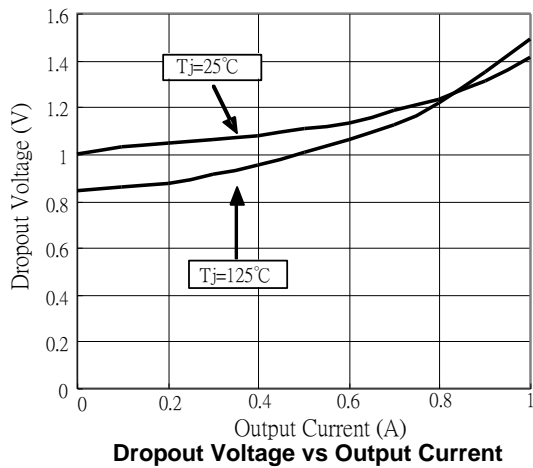

❖ PACKAGE OUTLINES

(1) SOT223-3L

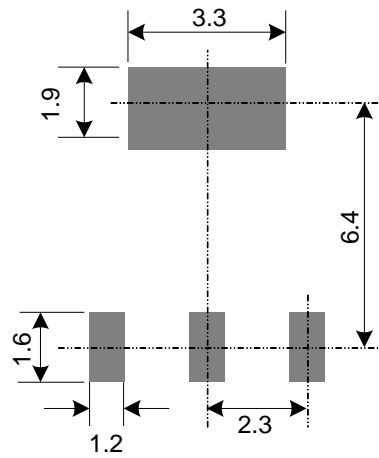
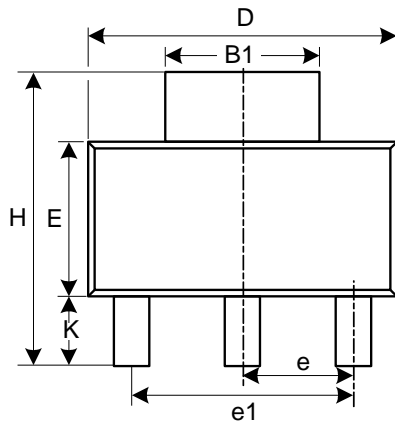

Land Pattern Recommendation (Unit: mm)

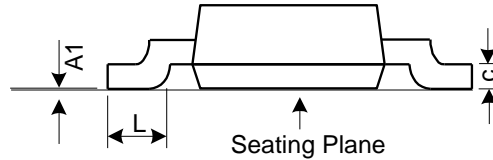
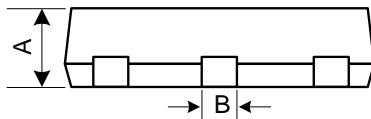

Symbol	Dimensions in Millimeters			Dimensions in Inches		
	Min.	Nom.	Max.	Min.	Nom.	Max.
A	-	-	1.8	-	-	0.071
A1	0.02	0.06	0.1	0.001	0.002	0.004
B	0.66	0.75	0.84	0.026	0.03	0.033
B1	2.9	3	3.1	0.114	0.118	0.122
C	0.23	0.315	0.35	0.009	0.012	0.014
D	6.3	6.5	6.7	0.248	0.256	0.264
E	3.3	3.5	3.7	0.13	0.138	0.146
H	6.7	7	7.3	0.264	0.278	0.287
L	0.75	-	-	0.03	-	-
K	1.5	1.75	2	0.059	0.069	0.079
e	2.3 Basic			0.091 Basic		
e1	4.6 Basic			0.181 Basic		

JEDEC outline: TO-261 AB

(2) T0252-3L

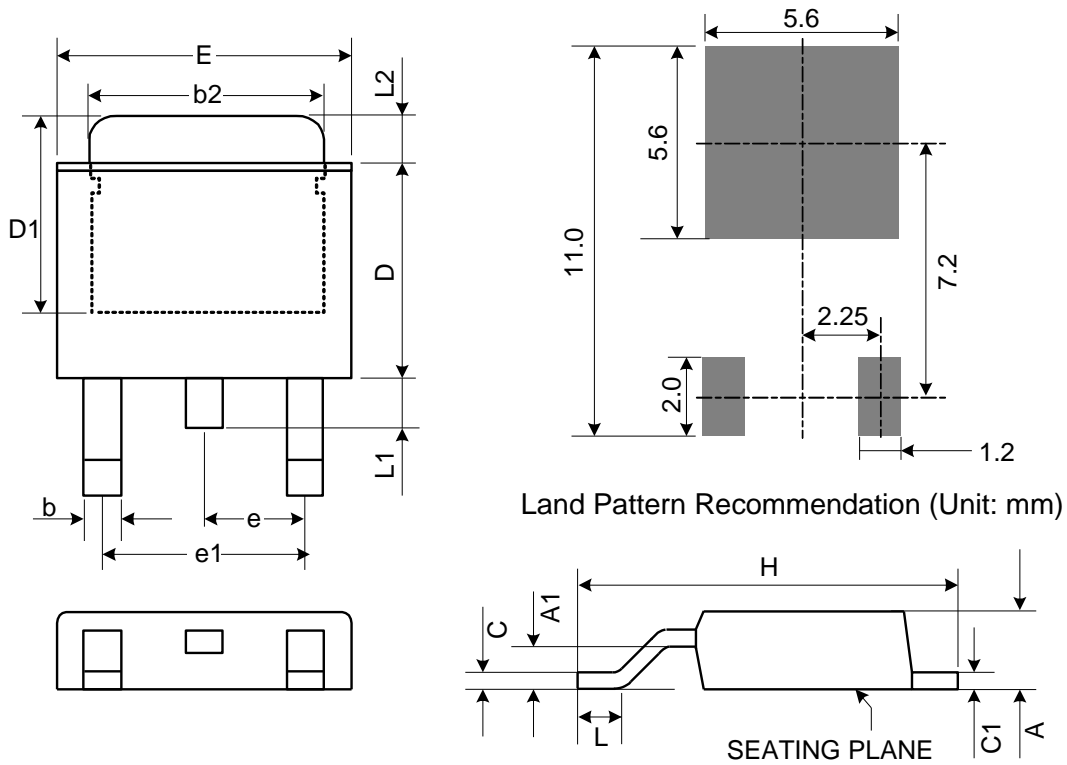

Symbol	Dimensions in Millimeters			Dimensions in Inches		
	Min.	Nom.	Max.	Min.	Nom.	Max.
A	2.18	2.29	2.39	0.086	0.09	0.094
A1	-	-	0.13	-	-	0.005
b	0.51	0.71	0.89	0.02	0.028	0.035
b2	4.95	5.21	5.46	0.195	0.205	0.215
C	0.46	0.53	0.61	0.018	0.021	0.024
C1	0.46	0.53	0.58	0.018	0.021	0.023
D	5.33	5.46	5.59	0.21	0.215	0.22
D1	4.57	-	-	0.18	-	-
E	6.35	6.55	6.73	0.25	0.258	0.265
e	2.29 BSC			0.090 BSC.		
e1	4.58 BSC			0.180 BSC.		
H	9.4	9.7	10.4	0.37	0.382	0.41
L	1.4	1.6	1.78	0.055	0.063	0.07
L1	-	-	1.02	-	-	0.04
L2	1.52	1.78	2.03	0.06	0.07	0.08

Mold flash shall not exceed 0.005inch per side
JEDEC outline: TO-252 AB

X-ON Electronics

Largest Supplier of Electrical and Electronic Components

Click to view similar products for [LDO Voltage Regulators](#) category:

Click to view products by [Axelite](#) manufacturer:

Other Similar products are found below :

[AP7363-SP-13](#) [L79M05TL-E](#) [AP7362-HA-7](#) [PT7M8202B12TA5EX](#) [TCR3DF185,LM\(CT](#) [TCR3DF45,LM\(CT](#) [TLE4473G V52](#) [059985X](#)
[NCP4687DH15T1G](#) [701326R](#) [NCV8170AXV250T2G](#) [AP7315-25W5-7](#) [AP2111H-1.2TRG1](#) [ZLDO1117QK50TC](#) [AZ1117ID-ADJTRG1](#)
[TCR3DG12,LF](#) [MIC5514-3.3YMT-T5](#) [SCD7912BTG](#) [NCP154MX180270TAG](#) [SCD33269T-5.0G](#) [NCV8170BXV330T2G](#)
[NCV8170BMX330TCG](#) [NCV8170AMX120TCG](#) [NCP706ABMX300TAG](#) [NCP153MX330180TCG](#) [NCP114BMX075TCG](#) [MC33269T-3.5G](#)
[CAT6243-ADJCMT5T](#) [TCR3DG33,LF](#) [TCR4DG35,LF](#) [TAR5S15U\(TE85L,F\)](#) [TAR5S18U\(TE85L,F\)](#) [TCR3UG19A,LF](#) [TCR4DG105,LF](#)
[MPQ2013AGG-5-P](#) [NCV8170AMX360TCG](#) [TLE4268GSXUMA2](#) [NCP715SQ15T2G](#) [MIC5317-3.0YD5-T5](#) [NCV563SQ18T1G](#)
[NCP715MX30TBG](#) [NCV8702MX25TCG](#) [NCV8170BXV120T2G](#) [MIC5317-1.2YD5-T5](#) [NCV8170AMX150TCG](#) [NCV8170BMX150TCG](#)
[AP2213D-3.3TRG1](#) [NCV8170BMX120TCG](#) [NCV8170BMX310TCG](#) [NCV8170BMX360TCG](#)