

## **300mA Low Dropout (LDO) Linear Regulator**

### ❖ GENERAL DESCRIPTION

The AX6601 is a 300mA, fixed output voltage, low dropout linear regulator. The Device includes pass element, error amplifier, band-gap, current-limit, and thermal shutdown circuitry. The characteristics of low dropout voltage and less quiescent current make it good for some critical current application, for example, some battery powered devices. The typical quiescent current is approximately 90 $\mu$ A. Due to internal flexible design, result in extensively fixed output voltage versions and make it convenient to use for applications. Built-in current-limit, short-circuit protection and thermal-shutdown functions prevent any fault condition from IC damage.

### ❖ FEATURES

- Input voltage range is up to 6V
- Dropout voltage 200mV at 150mA output current
- Guaranteed 300mA output current
- Low quiescent current 90 $\mu$ A (typ.)
- Fixed Output voltage is 1.5V, 1.8V, 2.5V, 2.8V, 3.0V and 3.3V.
- Fast transient response
- Current limit ,short-circuit protection and thermal shutdown protection
- Available in the SOT-23-3L and SOT-89-3L Packages

### ❖ BLOCK DIAGRAM

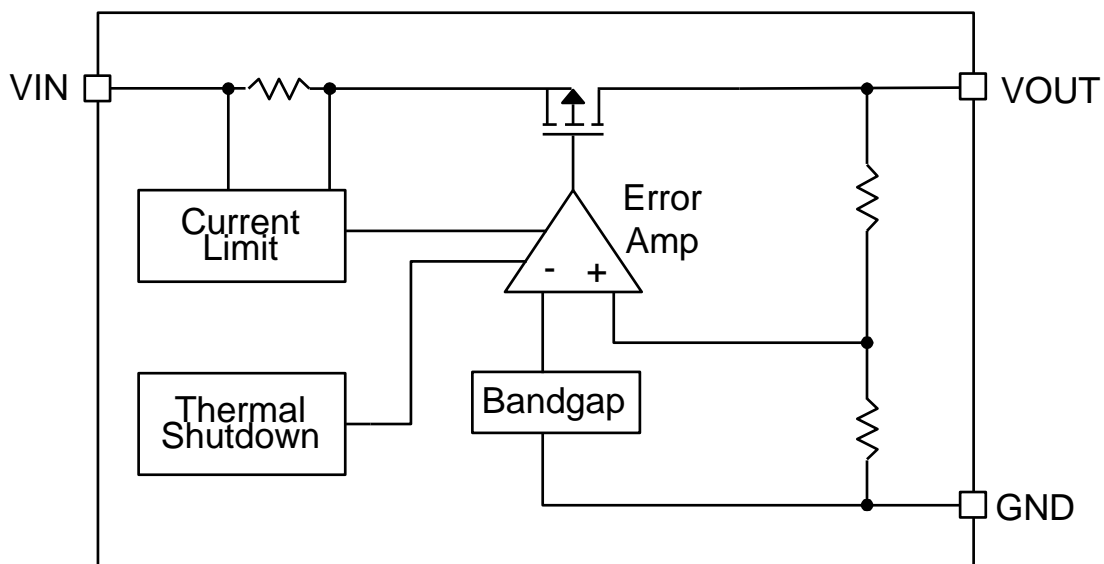



### ❖ ABSOLUTE MAXIMUM RATINGS (at T<sub>A</sub>=25 °C)

Characteristics		Symbol	Rating	Unit
VIN Pin Voltage		V <sub>IN</sub>	GND - 0.3 to GND + 6.5	V
Output Voltage		V <sub>OUT</sub>	GND - 0.3 to V <sub>IN</sub> + 0.3	V
Power Dissipation	SOT-23-3L	PD	400	mW
	SOT-89-3L		625	
Storage Temperature Range		T <sub>ST</sub>	-40 to +150	°C
Operating Junction Temperature		T <sub>J</sub>	-40 to +125	°C
Thermal Resistance from Junction to case	SOT-23-3L	θ <sub>JC</sub>	180	°C/W
	SOT-89-3L		100	
Thermal Resistance from Junction to ambient	SOT-23-3L	θ <sub>JA</sub>	250	°C/W
	SOT-89-3L		160	

Note: θ<sub>JA</sub> is measured with the PCB copper area of approximately 1 in<sup>2</sup> (Multi-layer). That need connect to V<sub>IN</sub> pin.

### ❖ ELECTRICAL CHARACTERISTICS

T<sub>A</sub>=25 °C (unless otherwise noted)

Characteristics	Symbol	Conditions	Min	Typ	Max	Units	
Input Voltage	V <sub>IN</sub>	(Note 1)	2.6	-	6	V	
Output Voltage Accuracy (Note2)	ΔV <sub>OUT</sub>	V <sub>IN</sub> =V <sub>OUT</sub> +0.1V to 6V V <sub>OUT</sub> ≥ 1.80V, I <sub>OUT</sub> =1mA	-3	-	+3	%	
		V <sub>IN</sub> =2.6V to 6V 1.80 > V <sub>OUT</sub> ≥ 1.20V, I <sub>OUT</sub> =1mA	-4	-	+4		
Dropout Voltage	V <sub>DROP</sub>	I <sub>OUT</sub> =300mA	V <sub>OUT</sub> =1.50V	-	1.10	1.3	V
			V <sub>OUT</sub> =1.80V	-	0.8	1.0	
			V <sub>OUT</sub> =2.50V	-	0.4	0.6	
			V <sub>OUT</sub> =2.80V	-	0.38	0.5	
			V <sub>OUT</sub> =3.00V	-	0.37	0.5	
			V <sub>OUT</sub> =3.30V	-	0.36	0.5	
Quiescent Current	I <sub>Q</sub>	I <sub>OUT</sub> =0mA, V <sub>IN</sub> =5V	-	90	-	μA	
Load Regulation (Note 3)	ΔV <sub>LOAD</sub>	I <sub>OUT</sub> =10m~300mA	-	-	0.02	%/mA	
Current Limit	I <sub>LIMIT</sub>	(Note 4)	350	600	-	mA	
Short Circuit Current	I <sub>SHORT</sub>	V <sub>OUT</sub> <1.0V	-	170	-	mA	
Ripple Rejection	PSRR	C <sub>IN</sub> =1μF, C <sub>O</sub> =2.2μF, I <sub>OUT</sub> =10mA	F=120Hz	-	60	-	dB
			F=1KHz	-	55	-	
Thermal Shutdown	T <sub>SD</sub>		-	150	-	°C	
Thermal Shutdown Hysteresis	T <sub>SH</sub>		-	30	-	°C	

Note1: Minimum V<sub>IN</sub> voltage is defined by output adds a dropout voltage.

Note2: V<sub>IN</sub> minimum must larger than 2.6V.

Note3: Regulation is measured at constant junction temperature by using pulsed testing with a low ON time.

Note4: V<sub>IN</sub>=V<sub>OUT</sub>+V<sub>DROP (Max.)</sub>+0.5V, Current limit is measured at constant junction temperature by using pulsed testing with a low ON time.

## ❖ APPLICATION CIRCUIT

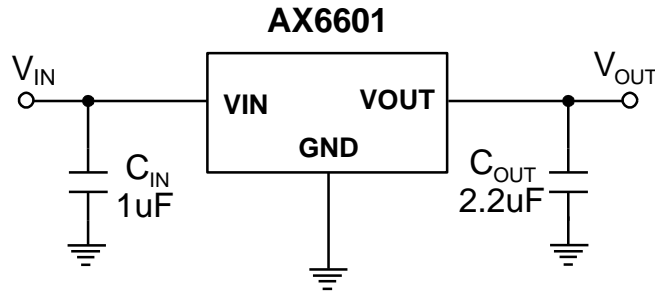

## ❖ FUNCTION DESCRIPTIONS

A minimum of 2.2μF capacitor must be connected from  $V_{OUT}$  to ground to insure stability. Typically a large storage capacitor is connected from  $V_{IN}$  to ground to ensure that the input voltage does not sag below the minimum dropout voltage during the load transient response. This pin must always be dropout voltage higher than  $V_{OUT}$  in order for the device to regulate properly.

## ❖ APPLICATION INFORMATION

Like any low-dropout regulator, the AX6601 requires input and output decoupling capacitors. The device is specifically designed for portable applications requiring minimum board space and smallest components. These capacitors must be correctly selected for good performance (see Capacitor Characteristics Section). Please note that linear regulators with a low dropout voltage have high internal loop gains which require care in guarding against oscillation caused by insufficient decoupling capacitance.

### Capacitor Selection

Normally, use a 1μF capacitor on the input and a 2.2μF capacitor on the output of the AX6601. Larger input capacitor values and lower ESR (X5R, X7R) provide better supply-noise rejection and transient response. A higher- value output capacitor (10μF) may be necessary if large, fast transients are anticipated and the device is located several inches from the power source.

### Input-Output (Dropout) Voltage

A regulator's minimum input-to-output voltage differential (dropout voltage) determines the lowest usable supply voltage. In battery-powered systems, this determines the useful end-of-life battery voltage. Because the device uses a PMOS, its dropout voltage is a function of drain-to source on-resistance,  $R_{DS(ON)}$ , multiplied by the load current:

$$V_{DROPOUT} = V_{IN} - V_{OUT} = R_{DS(ON)} \times I_{OUT}$$

## Current Limit and Short-Circuit Protection

The AX6601 uses a current sense-resistor to monitor the output current. A portion of the PMOS output transistor's current is mirrored to a resistor such that the voltage across this resistor is proportional to the output current. Once the output current exceeds limit threshold, AX6601 would be protected with a limited output current. Further more, when the output is short to ground, the output current would be folded-back to a less limit.

## Thermal Considerations

The AX6601 series can deliver a current of up to 300mA over the full operating junction temperature range. However, the maximum output current must be dated at higher ambient temperature to ensure the junction temperature does not exceed 125°C. With all possible conditions, the junction temperature must be within the range specified under operating conditions. Power dissipation can be calculated based on the output current and the voltage drop across regulator.

$$P_D = (V_{IN} - V_{OUT}) I_{OUT}$$

The final operating junction temperature for any set of conditions can be estimated by the following thermal equation:

$$P_{D(MAX)} = (T_{J(MAX)} - T_A) / \theta_{JA}$$

Where  $T_{J(MAX)}$  is the maximum junction temperature of the die (125°C) and  $T_A$  is the maximum ambient temperature. The junction to ambient thermal resistance ( $\theta_{JA}$ ) for SOT-23-3L package at recommended minimum footprint is 250°C/W.

## PCB Layout

An input capacitance of  $\cong 1\mu F$  is required between the AX6601 input pin and ground (the amount of the capacitance may be increased without limit), this capacitor must be located a distance of not more than 1cm from the input and return to a clean analog ground. Input capacitor can filter out the input voltage spike caused by the surge current due to the inductive effect of the package pin and the printed circuit board's routing wire. Otherwise, the actual voltage at the IN pin may exceed the absolute maximum rating. The output capacitor also must be located a distance of not more than 1cm from output to a clean analog ground. Because it can filter out the output spike caused by the surge current due to the inductive effect of the package pin and the printed circuit board's routing wire.

❖ TYPICAL CHARACTERISTICS

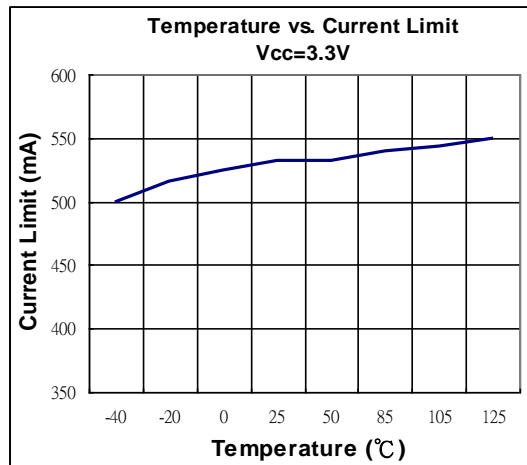
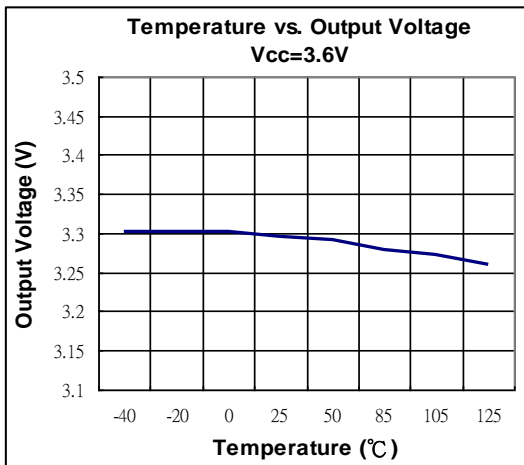
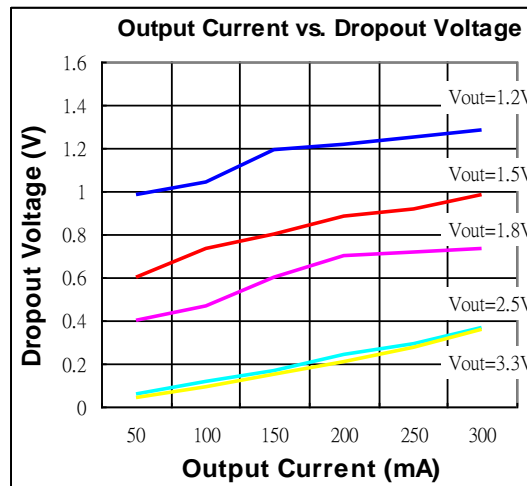
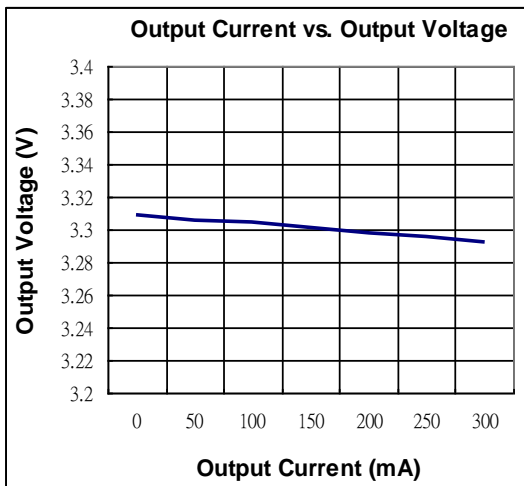
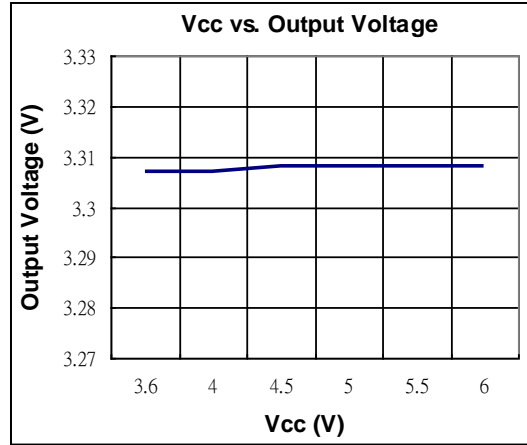
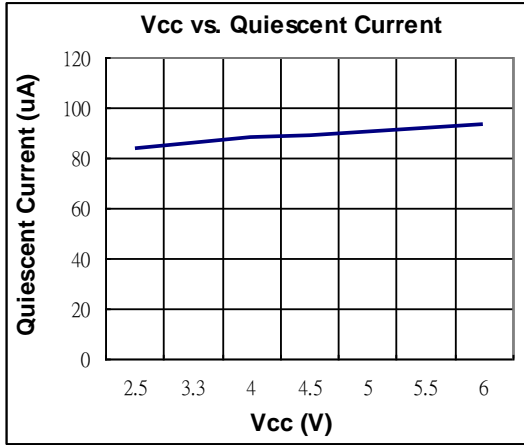

❖ TYPICAL CHARACTERISTICS (CONTINUES)

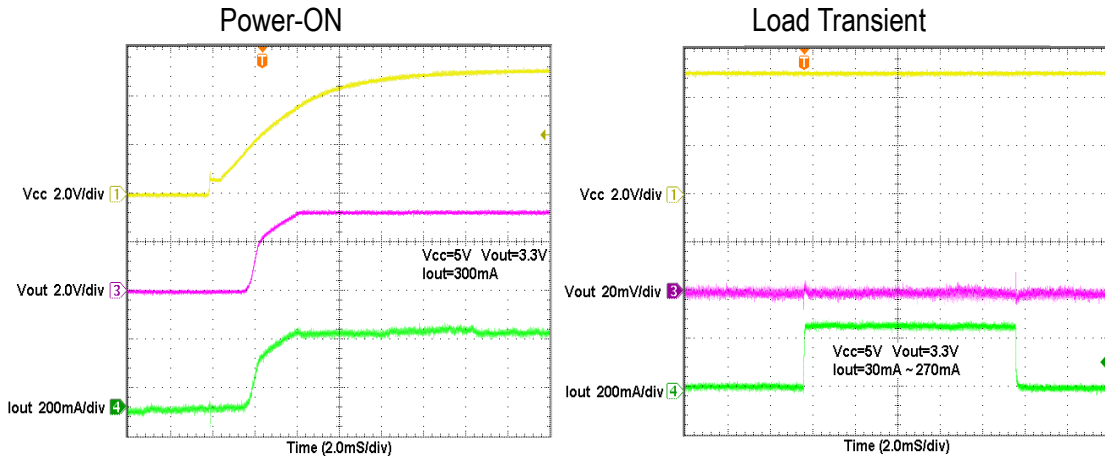

❖ PACKAGE OUTLINES

(1) SOT-23-3L

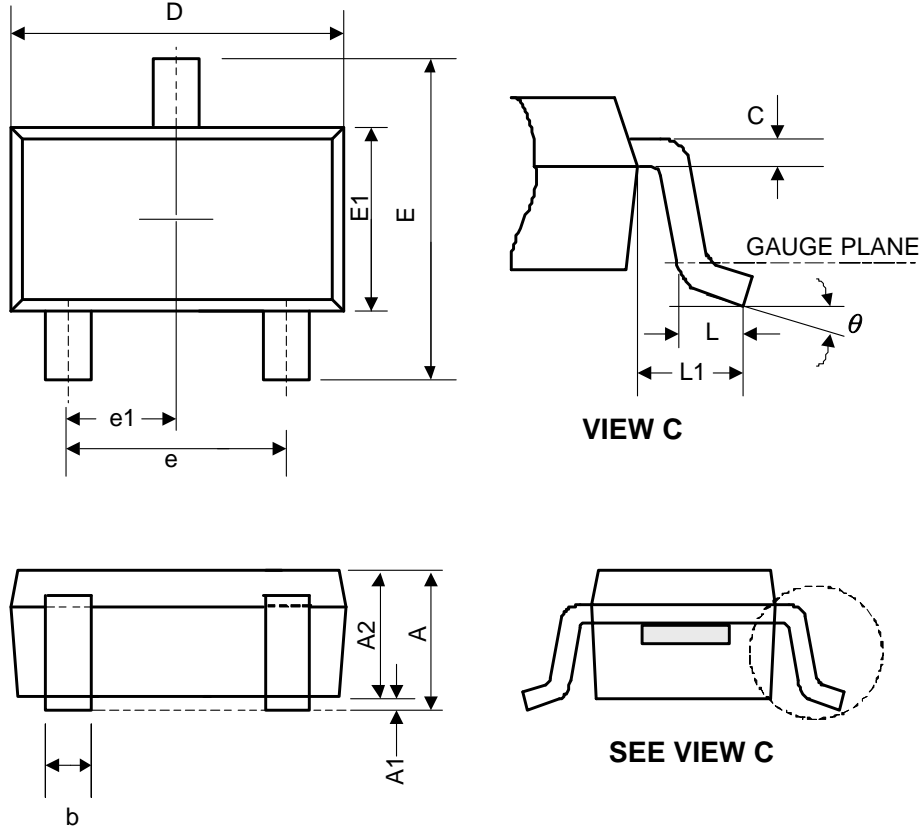

Symbol	Dimensions in Millimeters			Dimensions in Inches		
	Min.	Nom.	Max.	Min.	Nom.	Max.
A	-	-	1.45	-	-	0.057
A1	0	0.08	0.15	-	-	0.006
A2	0.9	1.1	1.3	0.035	0.043	0.051
b	0.3	0.4	0.5	0.012	0.016	0.02
C	0.08	0.15	0.22	0.003	0.006	0.009
D	2.7	2.9	3.1	0.106	0.114	0.122
E	2.6	2.8	3	0.102	0.11	0.118
E1	1.4	1.6	1.8	0.055	0.063	0.071
L	0.3	0.45	0.6	0.012	0.018	0.024
L1	0.5	0.6	0.7	0.02	0.024	0.028
e	1.9 BSC			0.075 BSC		
e1	0.95 BSC			0.037 BSC		
$\theta$	0°	4°	8°	0°	4°	8°

JEDEC outline: NA



(2) SOT-89-3L

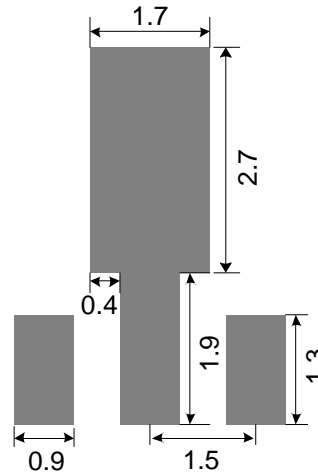
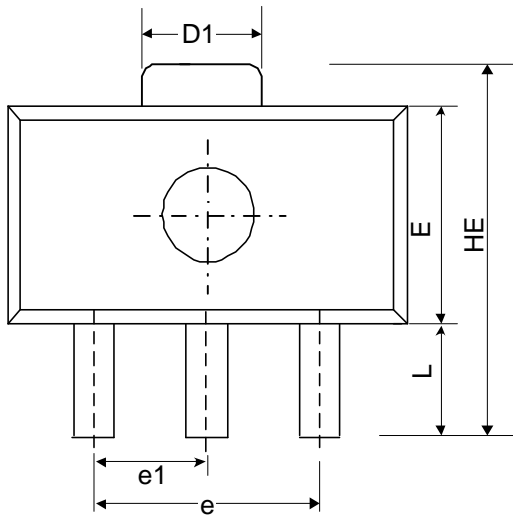

Land Pattern Recommendation (Unit: mm)

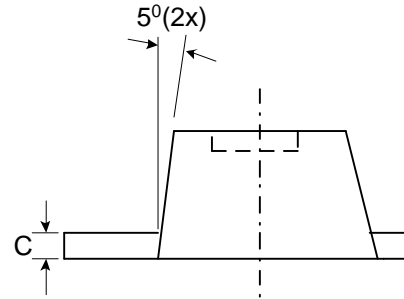
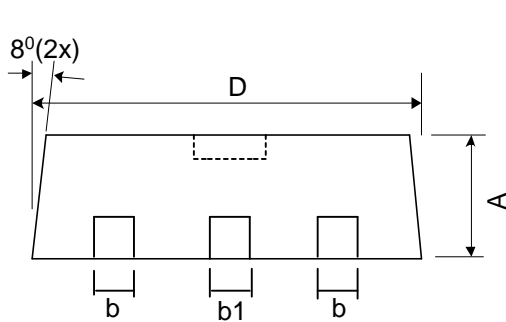

Symbol	Dimensions in Millimeters			Dimensions in Inches		
	Min.	Nom.	Max.	Min.	Nom.	Max.
A	1.4	1.5	1.6	0.055	0.059	0.063
b	0.36	0.42	0.48	0.014	0.017	0.019
b1	0.44	0.5	0.56	0.017	0.02	0.022
C	0.35	0.4	0.44	0.014	0.016	0.017
D	4.4	4.5	4.6	0.173	0.177	0.181
D1	1.35	1.59	1.83	0.053	0.063	0.072
e	3.0 BSC			0.118 BSC		
e1	1.5 BSC			0.059 BSC		
E	2.29	2.45	2.6	0.09	0.097	0.102
HE	3.94	4.1	4.25	0.155	0.161	0.167
L	0.8	1	1.2	0.031	0.04	0.047

JEDEC outline: TO-243 AB

## X-ON Electronics

Largest Supplier of Electrical and Electronic Components

*Click to view similar products for [LDO Voltage Regulators](#) category:*

*Click to view products by [Axelite](#) manufacturer:*

Other Similar products are found below :

[AP7363-SP-13](#) [L79M05TL-E](#) [AP7362-HA-7](#) [PT7M8202B12TA5EX](#) [TCR3DF185,LM\(CT](#) [TCR3DF45,LM\(CT](#) [TLE4473G V52](#) [059985X](#)  
[NCP4687DH15T1G](#) [701326R](#) [NCV8170AXV250T2G](#) [AP7315-25W5-7](#) [AP2111H-1.2TRG1](#) [ZLDO1117QK50TC](#) [AZ1117ID-ADJTRG1](#)  
[TCR3DG12,LF](#) [MIC5514-3.3YMT-T5](#) [SCD7912BTG](#) [NCP154MX180270TAG](#) [SCD33269T-5.0G](#) [NCV8170BXV330T2G](#)  
[NCV8170BMX330TCG](#) [NCV8170AMX120TCG](#) [NCP706ABMX300TAG](#) [NCP153MX330180TCG](#) [NCP114BMX075TCG](#) [MC33269T-3.5G](#)  
[CAT6243-ADJCMT5T](#) [TCR3DG33,LF](#) [TCR4DG35,LF](#) [TAR5S15U\(TE85L,F\)](#) [TAR5S18U\(TE85L,F\)](#) [TCR3UG19A,LF](#) [TCR4DG105,LF](#)  
[MPQ2013AGG-5-P](#) [NCV8170AMX360TCG](#) [TLE4268GSXUMA2](#) [NCP715SQ15T2G](#) [MIC5317-3.0YD5-T5](#) [NCV563SQ18T1G](#)  
[NCP715MX30TBG](#) [NCV8702MX25TCG](#) [NCV8170BXV120T2G](#) [MIC5317-1.2YD5-T5](#) [NCV8170AMX150TCG](#) [NCV8170BMX150TCG](#)  
[AP2213D-3.3TRG1](#) [NCV8170BMX120TCG](#) [NCV8170BMX310TCG](#) [NCV8170BMX360TCG](#)