



IQS128 Datasheet

IQ Switch® - ProxSense® Series

Single Channel Capacitive Proximity/Touch Controller

The IQS128 ProxSense® IC is a fully integrated capacitive sensor implementing Dynamic Calibration (DYCAL™) technology: intelligent hysteresis to allow for sensor drift even during sensor activation.

Features

- DYCAL™ : Intelligent Hysteresis
- Internal Capacitor Implementation (ICI) – reference capacitor on-chip
- Automatic Tuning Implementation (ATI) - Automatic adjustment for optimal sensor performance
- Supply voltage: 2.95V to 5.5V
- Minimum external components
- 1-Wire open drain data streaming option
- Advanced on-chip digital signal processing
- User selectable (OTP):
 - External synchronisation control or
 - External control over filter operation
 - I/O Sink or Source selection
 - Time-out for stuck key
 - Proximity and Touch sensitivity selections

Keys:	Touch:	5mm x 5mm or larger (overlay thickness dependent)
	Proximity:	Various electrical options (wire / PCB trace / ITO / conductive foil)
Dielectric:	Material:	Various non-metal materials (i.e. glass, plastic, painted surfaces)
	Thickness:	6 mm plastic, 10 mm glass for touch. Very thick overlay possible for proximity

Applications

- Occupancy sensors
- SAR qualification for Tablet PC's
- On-ear detection for mobile phones
- 3D glasses
- Personal Media Players
- White goods and appliances
- Human Interface Devices
- Proximity activated backlighting
- Any applications where a touch and proximity condition can prevail for an extended period of time with or without a host controller

Advantages

- Allows for sensor drift in periods of activation and non-activation
- Improved digital filtering to reduce external noise
- Minimal power consumption (<7µA) when in standby mode (Charge Halt).

Available Options

T_A	TSOT23-6
-40°C to 85°C	IQS128



Contents

1	OVERVIEW	3
2	PIN-OUT	4
3	USER CONFIGURABLE OPTIONS.....	5
4	MEASURING CAPACITANCE USING THE <i>CHARGE TRANSFER</i> METHOD.....	7
5	DYCAL™	8
6	CONFIGURABLE SETTINGS	9
7	STREAMING MODE.....	12
8	AUTOMATIC TUNING IMPLEMENTATION (ATI).....	13
9	TYPICAL APPLICATIONS	15
10	ELECTRICAL SPECIFICATIONS	16
11	PACKAGING AND PART-NUMBER INFORMATION.....	19
12	DATASHEET REVISION HISTORY.....	22
APPENDIX A. CONTACT INFORMATION.....		23
APPENDIX B.....		23



1 Overview

1.1 Device

The IQS128 is a single channel capacitive proximity and touch device which employs an internal voltage regulator and reference capacitor (Cs).

The IQS128 device has a dedicated pin for the connection of a sense electrode (Cx) and output pin for proximity and touch events on OUT. The polarity of the output pins can be configured. A 1-wire open drain data streaming protocol is implemented for debugging purposes.

Special device configuration can be done by setting one time programmable (OTP) options.

The device automatically tracks slow varying environmental changes via various signal processing algorithms and has an Automatic Tuning Implementation (ATI) algorithm to calibrate the device to the sense electrode.

DYCAL™ (Dynamic Calibration) is a special form of hysteresis that can track slow varying environmental change even while the sensor is in a touch state.

The *charge transfer* method of capacitive sensing is employed on the IQS128. (The

charge transfer principle is thoroughly described in the application note: “AZD004 - Azoteq Capacitive Sensing”.)

1.2 Operation

The device has been designed to be used in applications where proximity is required and touch conditions can prevail for an extended period of time which may result in uncompensated drift in conventional capacitive sensors.

A low threshold is used to detect the proximity of an object, with a higher threshold for touch detection.

Dynamic Calibration is performed when a TOUCH condition is detected for longer than t_{DYCAL} . The hysteresis algorithm will now check for the release condition of the touch, while still tracking environmental changes

1.3 Applicability

All specifications, except where specifically mentioned otherwise, provided by this datasheet are applicable to the following ranges:

- Temperature: -40C to +85C
- Supply voltage (V_{DDHI}): 2.95V to 5.5V

2 Pin-Out

The IQS128 is available in a TSOT23-6 package.

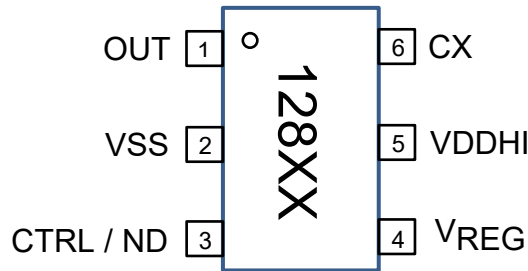
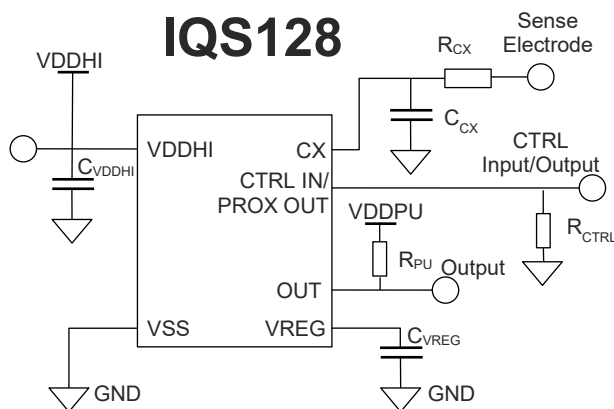

Figure 2.1 Pin-out of IQS128 package

Table 2.1 Pin-out description

IQS128			
Pin	Name	Type	Function
1	OUT	Digital Out	Output
2	VSS	Ground	GND Reference
3	CTRL / ND	Digital Input/Output	Control input or proximity output / ND pin
4	VREG	Analogue Output	Internal Regulator Pin (Connect 1µF bypass capacitor)
5	VDDHI	Supply Input	Supply Voltage Input
6	CX	Analogue	Sense Electrode

2.2 Schematic



Note: A 100pF capacitor can be placed in parallel with the existing capacitors between VDDHI and GND as well as between VREG and GND for added RF immunity.

Figure 2.2 Typical application schematic of IQS128

Typically $VDDHI = VDDPU$. Some applications require a lower voltage on the microprocessor side (typically $VDDHI = 3.3V$ and $VDDPU = 1.8V$). Refer to section 9 on Typical applications for more information about level shifting between the IQS128 and a microprocessor.

Table 2.2 Typical values

Component	Value	
	Typical	Maximum
C_{VREG}	1µF	n/a
R_{CX}	470 Ω	2 kΩ
C_{CX}	2pF**	10pF
R_{CTRL}	See Table 9.1	
R_{PU}^* ($VDDPU = 1.8V$)	4.7 kΩ	10 kΩ
R_{PU}^* ($VDDPU = 3.3V$)	10 kΩ	33 kΩ
C_{VDDHI}	1µF	n/a

* R_{PU} is only required if device is setup in an active Low state.

** If parasitic capacitance on PCB is high make DNP to optimize sensitivity



3 User Configurable Options

This section lists the user configurable settings.

The device is fully functional in its default state, but some applications may require alternative configuration settings. These settings are enabled by configuring One Time Programmable (OTP) user options.

Configuration can be done on packaged devices or in-circuit. In-circuit configuration may be limited by values of external components chosen.

Popular configurations are available ex-stock – please check with the local distributor for availability. Azoteq can supply pre-configured devices for large quantities.

3.1.1 IQS128 User Selectable Options

Table 3.1: IQS128 Bank 0 User Selectable Options

Bit	7	6	5	4	3	2	1	0
Name	T _{THR2}	T _{THR1}	T _{THR0}	P _{THR1}	P _{THR0}	~	LOGIC	EXT_CTRL
Default	0	0	0	0	0	0	0	0

bit 7-5	T_{THR<2:0>} : Touch Thresholds (counts) 000 = 16 001 = 40 010 = 60 011 = 90 100 = 130 101 = 200 110 = 340 111 = 500	-Section 6.5
bit 4-3	P_{THR<1:0>} : Proximity Thresholds (counts) 00 = 4 01 = 8 10 = 12 11 = 16	-Section 6.4
bit 1	LOGIC : Output logic select (Only when STREAMING mode is disabled) 0 = ¹ Software Open Drain Active Low 1 = Active High	-Section 6.7
bit 0	EXT_CTRL : Selects external control option on OUT 0 = Charge Halt 1 = Halt LTA filter	-Section 6.1

¹ Only applicable for OUT pin. If CTRL is configured as output, it is a push-pull output.



Table 3-2: IQS128 Bank 1 User Selectable Options

Bit	7	6	5	4	3	2	1	0
Name	STREAMING	~	~	T _{HALT1}	T _{HALT0}	~	~	CTRL_DIRECTION
Default	0	0	0	0	0	0	0	0

bit 7 **STREAMING:** 1-wire streaming protocol -Section 0
 0 = Disabled
 1 = Enabled

bit 6-5 **Unimplemented**

bit 4-3 **T_{THALT<1:0>}:** Filter Halt Settings -Section 6.7
 00 = Always
 01 = 18s
 10 = 60s
 11 = 3s

bit 2-1 **Unimplemented**

bit 0 **CTRL_DIRECTION:** Configures Control pin as input or output -Section 6.6
 0 = Input for external control from MCU (used with Bank0-bit 0)
 1 = Output Mode Operation

Table 3-3: IQS128 Bank 2 User Selectable Options

Bit	7	6	5	4	3	2	1	0
Name	~	~	~	~	~	ATI _{BASE1}	ATI _{BASE0}	~
Default	~	~	~	~	~	0	0	~

bit 7-4 **Unimplemented**

bit 2-1 **ATI_{BASE<1:0>}:** Base value selections -Section 8.1
 00 = 200 counts
 01 = 100 counts
 10 = 150 counts
 11 = 250 counts

bit 0 **Unimplemented**



4 Measuring capacitance using the *Charge Transfer* method

The *charge transfer* method of capacitive sensing is employed on the IQS128. (The charge transfer principle is thoroughly described in the application note: “AZD004 - Azoteq Capacitive Sensing”.)

A charge cycle is used to take a measurement of the capacitance of the sense electrode (connected to Cx) relative to ground. It consists of a series of pulses charging Cx and discharging Cx to the reference capacitor, at the charge transfer frequency (FCX - refer to Section 10). The number of the pulses required to reach a trip voltage on the reference capacitor is referred to as **counts (CS)** which is the instantaneous capacitive measurement. The CS value is used to determine if either a physical contact or a proximity event has occurred based on the change in CS detected. The typical values of CS, without a touch or a proximity condition range between 1344 and 1865, although higher and lower CS can be used based on the application

requirements. With CS larger than +/-1865 the gain of the system may become too high causing unsteady CS.

The IQS128 schedules a charge cycle every t_{SAMPLE} seconds to ensure regular samples for processing of results. The duration of the charge cycle is defined as t_{CHARGE} and varies according to the CS required to reach the trip voltage. Other activities, such as data streaming (if device is in streaming mode), are completed between charge cycles.

Please note: Attaching a probe to the Cx pin will increase the capacitance of the electrode and therefore the CS. This may have an immediate influence on the CS (decrease t_{CHARGE} – thus CS) and cause a proximity or a touch event. After t_{HALT} seconds the system will adjust to accommodate for this change. If the total load on Cx, with the probe attached is still lower than the maximum Cx load the system will continue to function normally after t_{HALT} seconds with the probe attached.

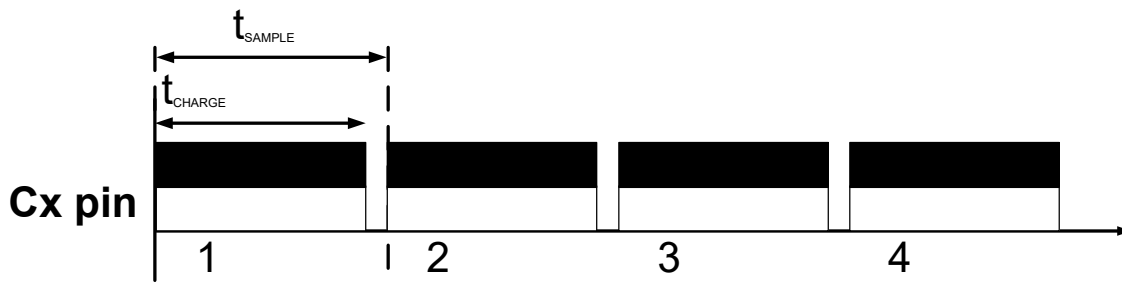

Figure 4.1 Charge cycles as can be seen on CX

5 DYCAL™

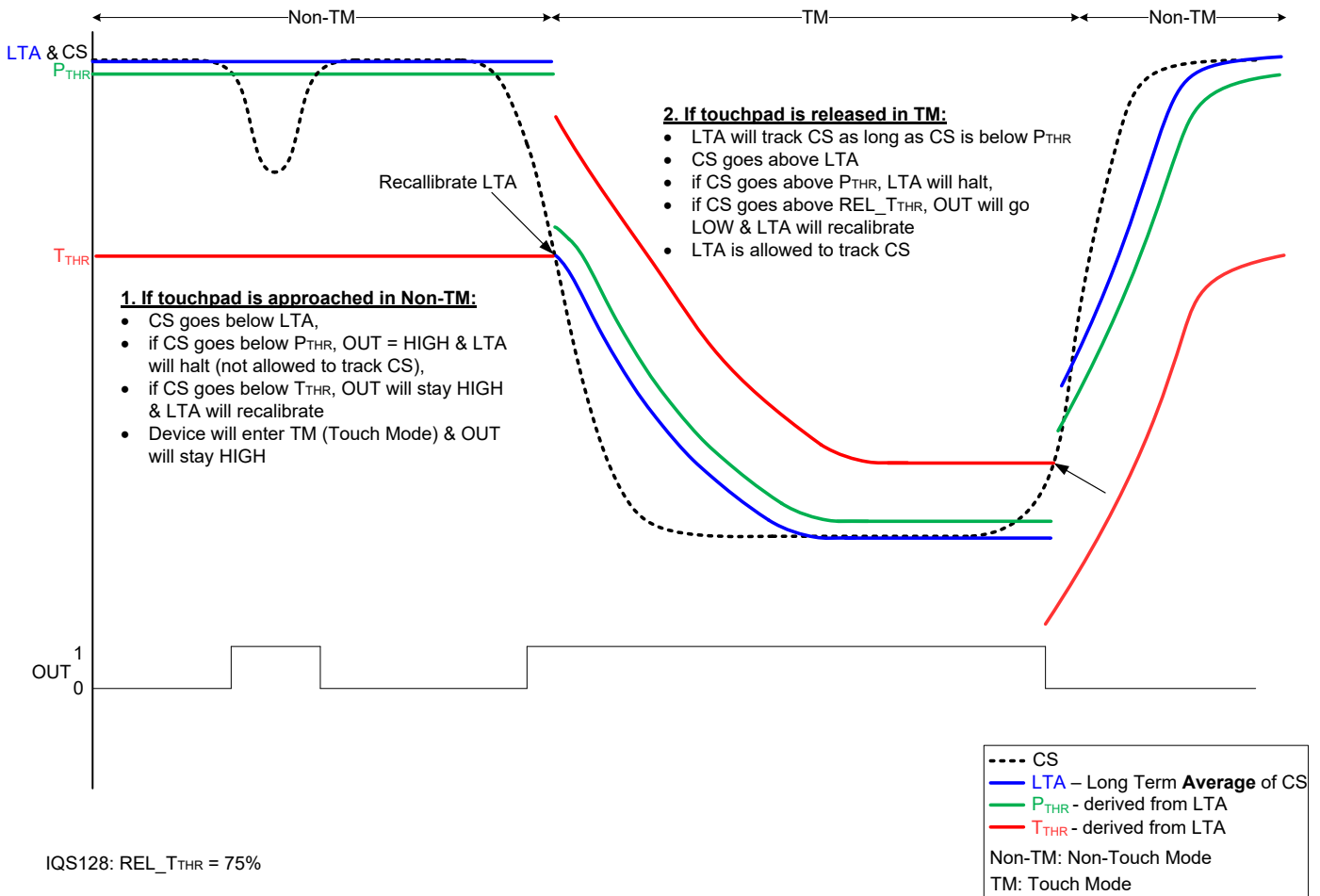

Figure 5.1 DYCAL Operation

5.1 Operating Principle

Figure 5.1 is a visual representation of the DYCAL functionality. The OUT pin is used to indicate the status of a DYCAL event (both a proximity and a touch event). The DYCAL functionality is summarised below.

5.2 Non-Touch Mode

The OUT pin is activated on the successful detection of a proximity event and will remain activated for the duration of the proximity event, permitting that this event is not longer than the filter halt timings. The LTA will be halted in this time.

As soon as a touch condition is detected (CS below T_{THR}), the controller will dynamically re-calibrate its LTA to the halted LTA – T_{THR} . The IC is now in Touch Mode.

5.3 Touch Mode

After the re-calibration of the LTA, it will follow the CS and be allowed to track slow varying environmental changes. If the CS were to exceed the LTA by a release threshold (REL_T_{THR}) the touch detection will stop and the OUT pin will return to its original state.

6 Configurable Settings

This section describes the user configurable options of the IQS128 in more detail.

User programmable options are selected by configuring the OTP selections. Please refer to section 0 for an overview of the configurable settings.

6.1 EXT_CTRL: External Control

The user has the option to control some parameters of the IQS128 from an external source. The IC can be used in default mode (CTRL unconnected) or the user can use the CTRL pin to select whether the master should halt the charge transfers (i.e. stop operation) or to halt LTA filter tracking on the IQS128. The EXT_CTRL input is to be regarded as a floating input and must be handled accordingly with external components or MCU. **See section 9.2 for a typical use reference design** with an active CTRL pin.

6.1.1 Charge Halt

If CTRL is sampled high for longer than T_{EXT_HALT} , the charge conversion cycle will be halted, once the current conversion has been completed. The device will remain in this standby mode until the CTRL line is sampled low again. An automatic reseed is performed directly after CTRL is released to compensate for any environmental changes which might have occurred during the standby mode.

6.1.2 Halt LTA filter

When configured in this mode, CTRL can be used to control the LTA halt times when sampled high. The CTRL pin has precedence over the configurations bits selected for the halt timings.

If CTRL is sampled high for longer than T_{EXT_HALT} , the filter will be halted until this pin is sampled low.

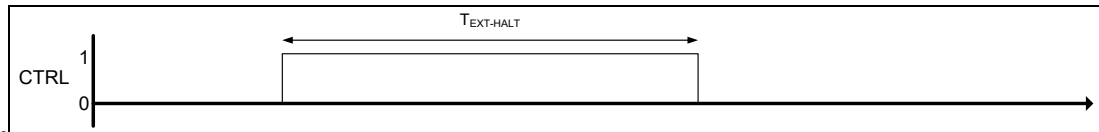

Figure 6.1 Master Output signal on CTRL pin to Halt Operation or Filter Halt

6.1.3 Pulse on CTRL:

The pulse on the CTRL pin needs to adhere to the following timing constraints:

$$25\text{ms} < T_{PULSE} < 35\text{ms}$$

6.1.3.1 IQS128: Reseed

A reseed condition can be initiated by generating a pulse on the CTRL pin. The

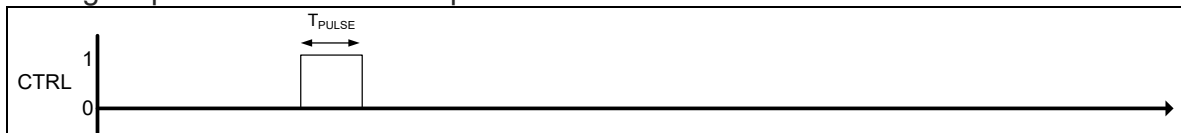

Figure 6.2 Master Output signal on CTRL to force a Reseed Condition

LTA will be reset to the CS, forcing the OUT pin to its original state.

If the CS value is outside its allowable limits, the device will force an ATI event to reset the system sensitivity. (Please refer to section 8 for more detail).



6.2 LOGIC

The logic used by the device can be selected as active HIGH or active LOW. The output pins OUT and CTRL will function based on this selection.

Configuration: Bank0 bit1: Logic Output Selection

Bit	Selection
0	Software Open Drain Active Low
1	Active High

A software open drain output is implemented for the OUT pin when configured in active low mode. The voltage on the pull-up resistor is limited to the IQS128 supply voltage. A 4k7-10kΩ resistor between OUT and VDDHI is recommended.

6.3 RF Noise

The IQS128 has advanced immunity to RF noise sources such as GSM cellular telephones, DECT, Bluetooth and WIFI devices. Design guidelines should however be followed to ensure the best noise immunity. The design of capacitive sensing applications can encompass a large range of situations but as a summary the following should be noted to improve a design:

- A ground plane should be placed under the IC, except under the Cx line.
- All the tracks on the PCB must be kept as short as possible.
- The capacitor between VDDHI and VSS as well as between VREG and VSS, must be placed as close as possible to the IC.
- A 100 pF capacitor should be placed in parallel with the 1uF capacitor between VDDHI and VSS. Another 100 pF capacitor can be placed in parallel with the 1uF capacitor between VREF and VSS.
- If the device is too sensitive for a specific application a parasitic capacitor (max 5pF) can be added between the Cx line and ground.
- Proper sense electrode and button design principles must be followed.
- Unintentional coupling of sense electrode to ground and other circuitry

must be limited by increasing the distance to these sources.

- In some instances a ground plane some distance from the device and sense electrode may provide significant shielding from undesired interference.

When the capacitance between the sense electrode and ground becomes too large the sensitivity of the device may be influenced.

6.4 P_{THR[1:0]} Proximity Threshold

The IQS128 has 4 proximity threshold settings indicated in CS. The proximity threshold is selected by the designer to obtain the desired sensitivity and noise immunity. A proximity event is triggered if the CS diverges more than the selected count from the LTA for 6 consecutive cycles.

IQS128

Configuration: Bank0 bit 4-3

P_{TH1}:P_{TH0}:Proximity Thresholds

Bit	Selection
00	4 (Most sensitive)
01	8
10	12
11	16 (Least sensitive)

6.5 T_{THR[2:0]} Touch Threshold

The IQS128 has 8 touch threshold settings indicated in CS. The touch threshold is selected by the designer to obtain the desired touch sensitivity. A touch event is triggered if the CS diverges more than the selected count from the LTA for 2 consecutive cycles.

In the NO-TOUCH state the CS must diverge more than the touch threshold value below the LTA. Operating in the TOUCH STATE, the CS must diverge more than REL_T_{THR} of the touch threshold value above the LTA.

The following equation is used to determine if a touch or release event occurred.

$$\text{NO TOUCH STATE: } \text{LTA} - \text{CS} \leq T_{\text{THR}}$$

$$\text{TOUCH STATE: } \text{CS} - \text{LTA} \geq \text{REL}_T_{\text{THR}}$$



IQS128

Configuration: Bank0 bit 7-5 T_{THR2} : T_{THR0} Touch Thresholds

Bit	Selection
000	16 (Most sensitive)
001	40
010	60
011	90
100	130
101	200
110	340
111	500 (Least sensitive)

6.6 CTRL_DIRECTION

The CTRL pin can be configured as an input (default) or as an output. If configured as input, the IC has an internal pull-up resistor

enabled. See Section 6.1 for more information on functionality of CTRL as input.

If the CTRL pin is configured as an output, it cannot be used to control the filter or charge transfer operation.

The CTRL pin is activated upon the successful detection of a proximity condition. The pin will remain activated for the duration of the proximity detection as indicated in Figure 6.3. If a proximity condition is detected in conjunction with a touch event, the pin will only be de-activated when the touch condition is no longer detected as indicated in figure below.

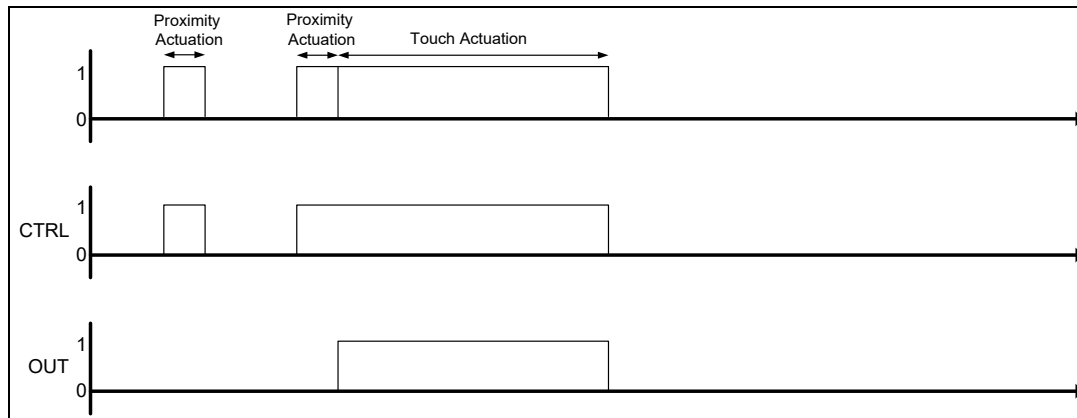

Figure 6.3 Proximity and Touch output

6.7 $T_{HALT[1:0]}$ Filter Halt

The LTA filter only executes while no proximity events are detected to ensure compensation only for environmental changes. Once a touch event is detected the filter will resume operation and will no longer be halted. The halt timing configuration settings determine how long the filter is halted.

as a fault state which would trigger a reseed event where after the output state on the OUT pin will be reset to its original condition.

Configuration: Bank1 bit 4-3 T_{HALT1} : T_{HALT0} LTA Halt timings for proximity events

Bit	Selection
00	ALWAYS
01	18 seconds
10	60 seconds
11	3 seconds

The presence of a proximity condition for a time exceeding the halt time will be deemed



7 Streaming Mode

For a more complete description of the data streaming protocol, please refer to [Application Note AZD040](#) on the Azoteq website.

The IQS128 has the capability to stream data to a MCU. This provides the designer the ability to obtain the parameters and sensor data within the device in order to aid design into applications. Data streaming is performed as a 1-wire data protocol on the OUT pin. The output function of this pin is therefore lost when the device is configured in streaming mode. Data Streaming can be enabled as indicated below:

Configuration: Bank1 bit7: Streaming Mode

Bit	Selection
0	Disabled
1	Enabled

1. Communications initiated by a START bit. Bit defined as a low condition for T_{START} .
2. Following the START bit, is a synchronisation byte ($T_{INIT} = 0xAA$). This byte is used by the MCU for clock synchronisation.
3. Following T_{INIT} the data bytes will be sent. With short data streaming mode enabled, 5 bytes of data will be sent, otherwise 8 bytes will be sent after each charge cycle.
4. Each byte sent will be preceded by a START bit and a STOP bit will follow every byte.
5. STOP bit indicated by taking pin 1 high. The STOP bit does not have a defined period.

Figure 7.1 illustrates the communication protocol for initialising and sending data with the 1 wire communication protocol.

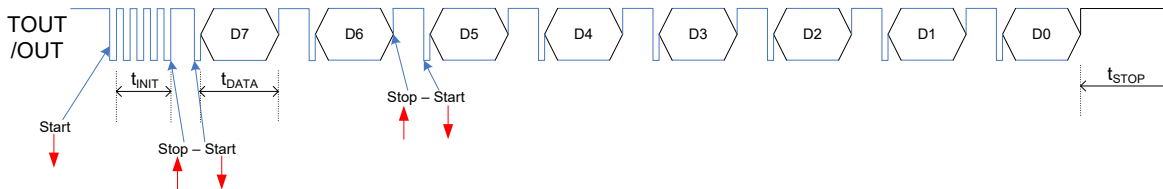

Figure 7.1 Debug: 1-wire streaming Debug Mode

The following table defines the bit definitions for the IQS128 devices during Streaming Mode.



Table 7-1: Byte Definitions for Streaming Mode

Byte	Bit	Value
0	7:0	CS High byte
1	15:8	CS Low byte
2	23:16	LTA High byte
3	31:24	LTA Low byte
4	39	ATI busy
	38	Proximity Event Detected
	37	Touch Event Detected
	36	OUT State Indication
	35	Not Used
	34	Zoom active
	33:32	Not Used
5	47	ATI Multiplier (I)
	46	ATI Multiplier (S)
	45	ATI Multiplier (S)
	44	Compensation (P4)
	43	Compensation (P3)
	42	Compensation (P2)
	41	Compensation (P1)
	40	Compensation (P0)
6	55:54	Not Used
	53	Compensation (P5)
	52	Touch Threshold Bit 2
	51	Touch Threshold Bit 1
	50	Touch Threshold Bit 0
	49	Proximity Threshold Bit 1
	48	Proximity Threshold Bit 0
7	63:56	Counter

Azoteq provides a [GUI](#) (Graphical User Interface) application that can be utilised to capture and visualise the data streamed from the IQS128.

8 Automatic Tuning Implementation (ATI)

ATI is a sophisticated technology implemented in the latest generation ProxSense® devices that optimises the performance of the sensor in a wide range of applications and environmental conditions (refer to application note AZD0027 - Automatic Tuning Implementation).

ATI makes adjustments through external reference capacitors unnecessary (as required by most other solutions) to obtain optimum performance.

8.1 ATI

The IQS128 implements an ATI algorithm. This algorithm adjusts the ATI parameters to optimise the sensing electrode's connection to the device.

The device will execute the ATI algorithm whenever the device starts-up and or when the CS are not within a predetermined range.

There are 2 important definitions to understand for ATI:

8.1.1 ATI Target

ATI adjusts internal circuitry according to two parameters, the **ATI multiplier** and the **ATI compensation**.

- The **ATI multiplier** can be viewed as a coarse adjustment of CS, used to achieve the ATI BASE value.
- The **ATI compensation** is a fine adjustment used to reach the ATI TARGET value.

With these two parameters the CS of the IQS128 is tuned until an ATI target value of 1600 is achieved.

8.1.2 ATIBASE: Significance of ATI Base

As mentioned above, the **ATI multiplier** is used to select a base value for the ATI. The ATI BASE value is important, as this determines the sensitivity of the device. The sensitivity can be defined as:

$$\text{Sensitivity} = \text{ATI TARGET} / \text{ATI BASE}$$



The ATI Target remains fixed at 1600 and it can thus be seen from this that a larger base value will result in a less sensitive device. The designer has the option to increase/reduce the sensitivity of the system through the ATI BASE value. For most applications the ATI BASE should be kept default.

The options for the ATI BASE is as follows:

Configuration: Bank2 bit 2-1

ATI_{BASE1}:ATI_{BASE0} ATI BASE values

Bit	Selection
00	200
01	100 (Most sensitive)
10	150
11	250 (Least sensitive)

8.2 Sensitivity due to ATI

The adjustment of the ATI parameters will result in variations in the CS and sensitivity. Sensitivity can be observed as the change in CS as the result of a fixed change in sensed capacitance. The ATI parameters have been chosen to provide significant overlap. It may therefore be possible to select various combinations of ATI multiplier and ATI compensation settings to obtain the same CS. The sensitivity of the various options may however be different for the same CS.

8.3 ATI Procedure

While the ATI algorithm is in progress this condition will be indicated in the streaming data and proximity and touch events cannot be detected. The device will only briefly remain in this condition and it will be entered only when relatively large shifts in the CS has been detected.

The ATI function aims to maintain a constant CS, regardless of the capacitance of the sense electrode (within the maximum range of the device).

The effects of ATI on the application are the following:

- Automatic adjustment of the device configuration and processing parameters for a wide range of PCB and application designs to maintain a optimal configuration for proximity and touch detection.

- Automatic tuning of the sense electrode at start-up to optimise the sensitivity of the application.
- Automatic re-tuning when the device detects changes in the sensing electrode's capacitance to accommodate a large range of changes in the environment of the application that influences the sensing electrode.
- Re-tuning only occurs during device operation when a relatively large sensitivity reduction is detected. This is to ensure smooth operation of the device during operation.
- Re-tuning may temporarily influence the normal functioning of the device, but in most instances the effect will be hardly noticeable.
- Shortly after the completion of the re-tuning process the sensitivity of a Proximity detection may be reduced slightly for a few seconds as internal filters stabilises.

ATI can be implemented so effectively due to:

- Excellent system signal to noise ratio (SNR).
- Effective digital signal processing to remove AC and other noise.
- The very stable core of the devices.
- The built-in capability to accommodate a large range of sensing electrode capacitances.

9 Typical applications

9.1 SAR

For SAR (Specific Absorption Rate) qualification applications it is recommended to use a large touch threshold to prevent DYCAL entry in normal proximity and qualification cases. Only a deep touch should enable DYCAL and enable a recalibration on release.

The options recommended for SAR are:

- IQS128 000E9 TSR
- IQS128 000E0 TSR

9.2 SAR - Typical CTRL pin use

All recommended SAR configurations has an active CTRL pin input.

When the CTRL pin function is not used, a pull-down resistor is required. The pin can also be connected directly to VSS. The value is specified in Table 9.1

When connecting the CTRL input to an MCU the device operation will follow the MCU pin output. The MCU pin power-up state will determine the IQS128 state. With the MCU pin as floating input at power-up, the IQS128 will be in an uncertain state (sleep or active) until the pin is forced in a direction.

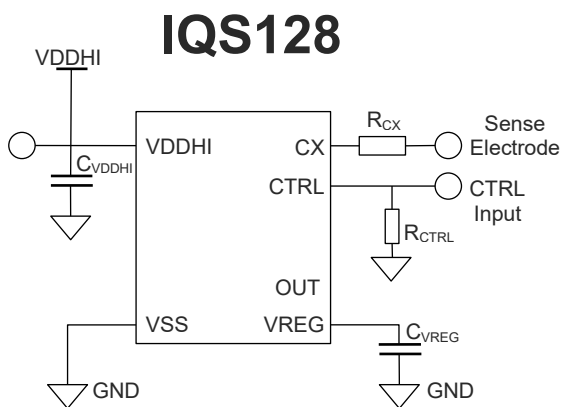

Figure 9.1 Schematic with recommended CTRL input pin use

Table 9.1 CTRL pin specifications

Component	Value	
	Minimum	Maximum
R _{CTRL}	0 Ω	100 kΩ
R _{CTRL} (CTRL to MCU)*	1 kΩ	100 kΩ

*R_{CTRL} to MCU is optional if MCU control is sufficient with power-up state uncertainty.

9.3 Mixed supply levels (VDDHI > VDDPU)

Typical use case for the IQS128 is to power the IC with a VDDHI of 3.3V and interface to a 1.8V microprocessor, implying VDDPU of 1.8V. This case requires the following:

Table 9.2 Mixed supply level requirements

Description	Requirement
Power up	$t_{\text{power_up_1v8}} \geq t_{\text{power_up_3v3}}$
Power up (alternative)	While $t_{\text{power_up_3v3}}$ force OUT pin 0V with MCU
Power down	VDDHI = 0V and VDDPU = 1.8V;
Power up failure case	$t_{\text{power_up_3v3}} \geq t_{\text{power_up_1v8}}$



10 Electrical Specifications

10.1 Absolute Maximum Specifications

Exceeding these maximum specifications may cause damage to the device.

Operating temperature	-40°C to 85°C
Supply Voltage ($V_{DDHI} - V_{SS}$) ²	6.5V
Maximum pin voltage (OUT, CTRL)	$V_{DDHI} + 0.5V$
Pin voltage (Cx)	2.5V
Minimum pin voltage (VDDHI, VREG, OUT, CTRL, Cx)	$V_{SS} - 0.5V$
Minimum power-on slope	100V/s
ESD protection (VDDHI, VREG, V_{SS} , OUT, CTRL, Cx)	4kV

10.2 General Characteristics (Measured at 25°C)

Standard IQS128 devices are rated for supply voltages between 2.95V and 5.5V.

Table 10.1 IQS128 General Operating Conditions

DESCRIPTION	Conditions	PARAMETER	MIN	TYP	MAX	UNIT
Supply voltage		V_{DDHI}	2.95		5.50	V
Internal regulator output	$2.95 \leq V_{DDHI} \leq 5.5$	V_{REG}	2.35	2.50	2.65	V
Boost Power operating current	$2.95 \leq V_{DDHI} \leq 5.5$	I_{IQS128_BP}		77		μA
Standby operating current ³	$2.95 \leq V_{DDHI} \leq 5.5$	$I_{STANDBY}$		7		μA

Table 10.2 Start-up and shut-down slope Characteristics

DESCRIPTION	IC	Conditions	PARAMETER	MIN	MAX	UNIT
POR	D/S	V_{DDHI} Slope $\geq 100V/s$	POR	1.45	1.70	V
BOD	D/S		BOD	1.30	1.40	V

² Maximum voltage applied for OTP programming and not intended for operation.

³ CTRL = Input and CTRL = HIGH (Charge halt).



10.3 Output Characteristics (Measured at 25°C)

Table 10.3 OUT Characteristics

Symbol	Description	I _{SOURCE} (mA)	Conditions	MIN	TYP	MAX	UNIT
V _{OH}	Output High voltage	1	V _{DDHI} = 5.5V	5.45	5.48	5.49	V
		1	V _{DDHI} = 3.3V	3.25	3.27	3.29	
		1	V _{DDHI} = 2.95V	2.85	2.9	2.95	
Symbol	Description	I _{SINK} (mA)	Conditions	MIN	TYP	MAX	UNIT
V _{OL}	Output Low voltage	1	V _{DDHI} = 5.5V	0.30	0.50	-	V
		1	V _{DDHI} = 3.3V	0.20	0.33	-	
		1	V _{DDHI} = 2.95V	0.20	0.25	-	

10.4 Timing Characteristics

Table 10.4 Main Oscillator⁴

SYMBOL	DESCRIPTION	Conditions	MIN	TYP	MAX	UNIT
F _{OSC}	IQS128 Main oscillator	2.95 ≤ V _{DDHI} ≤ 5.5	0.9	1	1.1	MHz

⁴ All timings are derived from the main oscillator.

Table 10.5 General Timing Characteristics for $2.95V \leq V_{DDHI} \leq 5.5V$

SYMBOL	DESCRIPTION	Conditions	MIN	TYP	MAX	UNIT
t _{HIGH}	Output high minimum time		9			ms
t _{LOW}	Output low minimum time		9			ms
F _{CX}	Charge transfer frequency			250		kHz
t _{CHARGE}	Charge cycle duration	CS = 1600, fcx = 250kHz		6.4		ms
t _{SAMPLE}	Refer to section 4			9		ms
t _{BP}	Sampling period in BP	t _{CHARGE} - 2 ≤ t _{SAMPLE}		9		ms
t _{BP}	Sampling period in BP	t _{CHARGE} ≥ t _{SAMPLE}		t _{CHARGE} +2		ms
t _{START}	Refer to section 7		14.4	17	18.8	us
t _{INIT}	Refer to section 7			136		us
t _{DATA}	Refer to section 7			136		us
t _{DYCAL}	Dynamic Calibration time	2.95 ≤ V _{DDHI} ≤ 5.5		250		ms
T _{EXT_HALT}	Halt Operation/Filter Halt time	2.95 ≤ V _{DDHI} ≤ 5.5		40		ms
T _{PULSE}	Pulse timing	2.95 ≤ V _{DDHI} ≤ 5.5	25	30	35	ms

Table 10.6 IQS128 Response Times

Power Mode	Conditions	DYCAL		
		Min*	Max	Unit
Boost Power Mode ⁵	Detection	63.7	-	ms
	Release	63.7	-	ms

**Minimum time calculated as causing a proximity detection on the IQS128. Prox debounce is 6 and I/O is toggled after next charge transfer cycle, requiring 7 charge cycles for the minimum time of a decision to be made.

⁵ IQS128 only available in Boost Power Mode. Minimum Detection and Release times = 7 x t_{CHARGE}



11 Packaging and Part-number Information

11.1 TSOT23-6

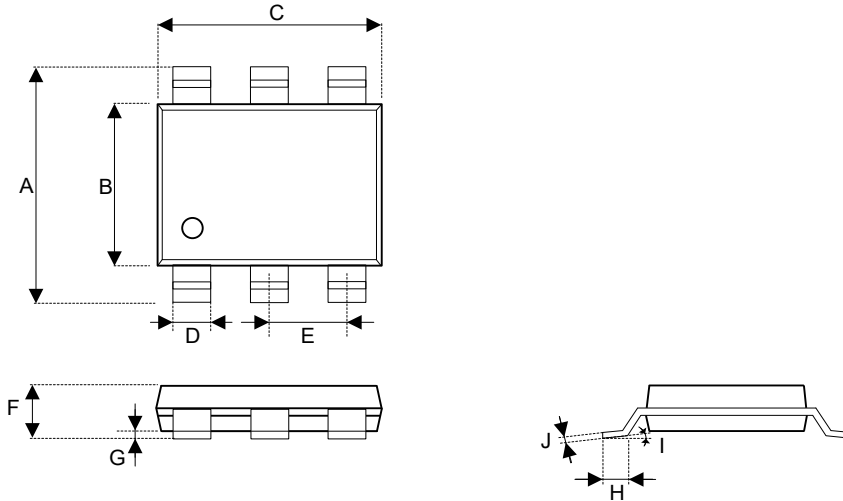

Figure 11.1 TSOT23-6 Packaging⁶

Table 11.1 TSOT23-6 Dimensions

Dimension	Min	Max	Tolerance
A	2.80 mm typ		Basic
B	1.60 mm typ		Basic
C	2.90 mm typ		Basic
D	0.40 mm		±0.10mm
E	0.95 mm typ		Basic
F	1.00mm		Max
G	0.05 mm		±0.05mm
H	0.40 mm		±0.10mm
I	4°		±4°
J	0.127 mm typ		+0.07/-0.007

⁶ Drawing not on Scale



11.2 TSOT23-6 Tape

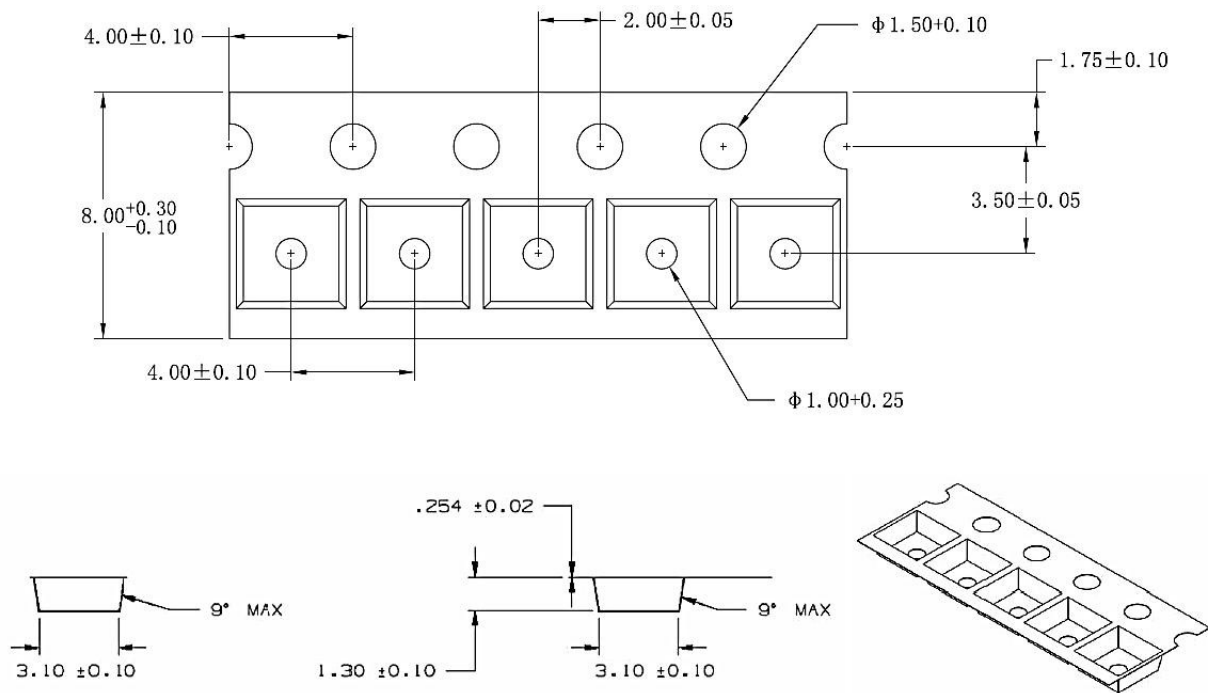

Figure 11.2 IQS128Tape Specification

11.3 Moisture Sensitivity Level (MSL)

Moisture Sensitivity Level relates to the packaging and handling precautions for some semiconductors. The MSL is an electronic standard for the time period in which a moisture sensitive device can be exposed to ambient room conditions (approximately 30°C/60%RH).

Increasingly, semiconductors have been manufactured in smaller sizes. Components such as thin fine-pitch devices and ball grid arrays could be damaged

during SMT reflow when moisture trapped inside the component expands.

The expansion of trapped moisture can result in internal separation (delamination) of the plastic from the die or lead-frame, wire bond damage, die damage, and internal cracks. Most of this damage is not visible on the component surface. In extreme cases, cracks will extend to the component surface. In the most severe cases, the component will bulge and pop.

IQS128 Packaging MSL Information

Package	Level (duration)
TSOT23-6	MSL1 (unlimited at ≤30 °C/85% RH)



11.4 Device Packaging Convention

11.4.1 Top

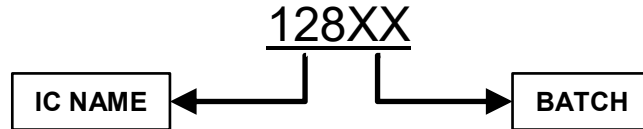

11.4.2 Bottom

Some batches IQS128 will not have any bottom markings. These devices are configured after marking, and may have variations in configuration – please refer to the reel label.

Other batches will display the configuration set on the chip on the bottom marking.



11.5 Ordering Information

Only full reels can be ordered and orders will be subject to a MOQ (Minimum Order Quantity) of a full reel. Contact the official distributor for sample quantities. A list of the distributors can be found under the “Distributors” section of www.azoteq.com.

For large orders, Azoteq can provide pre-configured devices.

The Part-number can be generated by using USBProg.exe or the Interactive Part Number generator on the website.

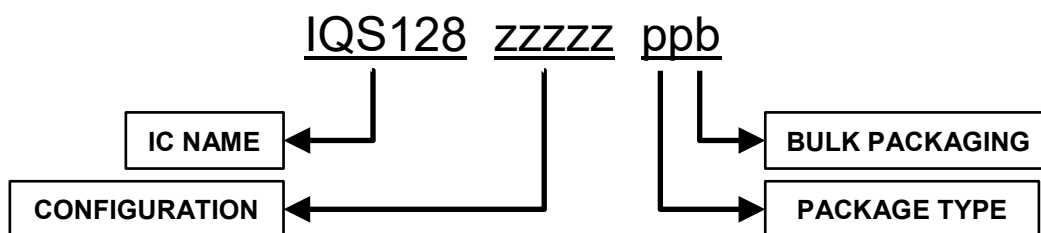

IC NAME	IQS128	=	IQS128
CONFIGURATION	zzzzz	=	IC Configuration (hexadecimal)
PACKAGE TYPE	TS	=	TSOT23-6
BULK PACKAGING	R	=	Reel (3000pcs/reel)
			MOQ = 1 reel.
			Mass production orders shipped as full reels.



12 Datasheet Revision History

- Version 1.10 Preliminary release
- Version 2.0 Added IQS128L and its functional differences
Added ATI BASE description
Added ND feature description for IQS128
- Version 2.1 Updated aesthetics
- Version 2.2 Changed QFN to DFN
Changed Power Mode names
- Version 2.3 Updated maximum operating voltage to 5.5 throughout document
Updated absolute maximum specification: Supply voltage to 6.5V. (Only intended for OTP programming!)
- Version 2.4 Updated POR and BOR table
Updated packaging and part-number information
Changed Current Sample references to Counts (CS)
Changed Antenna references to Electrode
Changed Auto-ATI references to ATI
Changed Device Markings
Added Tape/Reel Specification
Moved Section On Packaging Information to Section 12
Made Revision History a section on its own
Added Tape Specification
Added Errata to accommodate previous packaging
- Version 2.5 Improve images on front page
Add bottom marking description
Update contact information
- Version 2.6 Remove IQS128L information – This device has been made EOL.
- Version 2.7 Updated patent numbers and contact information
- Version 2.8 Added SAR configuration recommendations
Added level shifting application recommendations
Errata to prevent output failure with large R_{PU}
1-Wire streaming reference changed to AZD040
- Version 2.9 Output pin characteristics updated
- Version 3.0 External pull-down required on CTRL input pin. Document updated to include reference design. Section 6.1 updated and section 9.2 added.
- Version 3.1 Figure 2.2 & Table 2.2 updated to specify reference design capacitive load
- Version 3.2 Remove noise detection bit form OTP options.



	USA	Asia	South Africa
Physical Address	11940 Jollyville Suite 120-S Austin TX 78750 USA	Room 501A, Block A, T-Share International Centre, Taoyuan Road, Nanshan District, Shenzhen, Guangdong, PRC	1 Bergsig Avenue Paarl 7646 South Africa
Postal Address	11940 Jollyville Suite 120-S Austin TX 78750 USA	Room 501A, Block A, T-Share International Centre, Taoyuan Road, Nanshan District, Shenzhen, Guangdong, PRC	PO Box 3534 Paarl 7620 South Africa
Tel	+1 512 538 1995	+86 755 8303 5294 ext 808	+27 21 863 0033
Email	info@azoteq.com	info@azoteq.com	info@azoteq.com

Visit www.azoteq.com
for a list of distributors and worldwide representation.

Patents as listed on www.azoteq.com/patents-trademarks/ may relate to the device or usage of the device.

Azoteq®, Crystal Driver , IQ Switch®, ProxSense®, ProxFusion®, LightSense™, SwipeSwitch™, and the  logo are trademarks of Azoteq.

The information in this Datasheet is believed to be accurate at the time of publication. Azoteq uses reasonable effort to maintain the information up-to-date and accurate, but does not warrant the accuracy, completeness or reliability of the information contained herein. All content and information are provided on an "as is" basis only, without any representations or warranties, express or implied, of any kind, including representations about the suitability of these products or information for any purpose. Azoteq disclaims all warranties and conditions with regard to these products and information, including but not limited to all implied warranties and conditions of merchantability, fitness for a particular purpose, title and non-infringement of any third party intellectual property rights. Azoteq assumes no liability for any damages or injury arising from any use of the information or the product or caused by, without limitation, failure of performance, error, omission, interruption, defect, delay in operation or transmission, even if Azoteq has been advised of the possibility of such damages. The applications mentioned herein are used solely for the purpose of illustration and Azoteq makes no warranty or representation that such applications will be suitable without further modification, nor recommends the use of its products for application that may present a risk to human life due to malfunction or otherwise. Azoteq products are not authorized for use as critical components in life support devices or systems. No licenses to patents are granted, implicitly, express or implied, by estoppel or otherwise, under any intellectual property rights. In the event that any of the abovementioned limitations or exclusions does not apply, it is agreed that Azoteq's total liability for all losses, damages and causes of action (in contract, tort (including without limitation, negligence) or otherwise) will not exceed the amount already paid by the customer for the products. Azoteq reserves the right to alter its products, to make corrections, deletions, modifications, enhancements, improvements and other changes to the content and information, its products, programs and services at any time or to move or discontinue any contents, products, programs or services without prior notification. For the most up-to-date information and binding Terms and Conditions please refer to www.azoteq.com.

X-ON Electronics

Largest Supplier of Electrical and Electronic Components

Click to view similar products for [Capacitive Touch Sensors](#) category:

Click to view products by [Azoteq](#) manufacturer:

Other Similar products are found below :

[FK 8-1](#) [SMBTASK3KIT6](#) [LC717A30UR-NH](#) [CR12CN04DPO-E2](#) [CR30SCF10ATO](#) [CR30SCF10DPO](#) [BCS M30BBI2-PSC15D-S04K](#)
[FDC1004DGST](#) [CR18SCF05DPO](#) [CDWM3020ZPM](#) [MTCH6301-I/ML](#) [AT42QT1011-TSHR](#) [BCS M12B4G2-PSC40D-S04K](#) [BCS](#)
[M12B4I1-PSC40D-EP02](#) [CFAK 12P1103](#) [CFAK 12P1140/L](#) [CFAK 18P1100](#) [CFAK 18P1200](#) [CFAK 30P1100](#) [CFAM 12P1600](#) [CFAM](#)
[18P1600](#) [CFAM 18P1600/S14](#) [CFAM 30P1600](#) [CQ28-10NPP-KW1](#) [CR12CN04DNC](#) [KN056050](#) [KN086050](#) [KN186050](#) [KV750450](#)
[KV750455](#) [17-9291-226](#) [98-0003-3048-4](#) [CR12CN04DNO-E2](#) [PROXISWITCH](#) [CR12CN04DPO](#) [BCS M12BBG1-PSC80H-EP02](#) [BCS](#)
[M30B4I1-PSC15D-EP02](#) [BCS M18B4G2-PSC15H-S04K](#) [CR18CF05DPO-E2](#) [CM30-25NPP-EW1](#) [CM30-25NNP-EW1](#) [CM30-16BPP-EW1](#)
[CM30-16BNP-EW1](#) [CM18-12NPP-EW1](#) [CM18-12NPP-EC1](#) [CM18-12NNP-EW1](#) [CM18-12NNP-EC1](#) [CM18-08BPP-EW1](#) [CM18-08BNP-](#)
[EW1](#) [CM30-25NNP-EC1](#)