



IQS625 Datasheet

Combination sensor including: Hall-effect rotation sensing, along with dual-channel capacitive proximity/touch sensing.

The IQS625 ProxFusion® IC is a multifunctional capacitive and Hall-effect sensor designed for applications where any or all of the technologies may be required. The two Hall-effect sensors calculate the angle of a magnet rotating parallel with the sensor. The sensor is fully I²C compatible and on-chip calculations enable the IC to stream the current angle interval of the magnet without extra calculations.

Features

- **Hall effect angle sensor:**
 - On-chip Hall plates
 - Absolute Wheel Interval Output
 - Up to 36 intervals
 - Raw data: can be used to calculate degrees on external processor.
 - Wide operational range
 - No external components required
- **Partial auto calibration:**
 - Continuous auto-calibration, compensation for wear or small displacements of the sensor or magnet.
 - Flexible gain control
 - **Automatic Tuning Implementation (ATI)** – Performance enhancement (10 bit).
- **Capacitive sensing**
 - Full auto-tuning with adjustable sensitivity
 - 2pF to 200pF external capacitive load capability

Multiple integrated UI

- Proximity / Touch
 - Proximity wake-up
 - Event mode
 - Wake Hall sensing on proximity
 - Interval wake-up
 - Minimal external components
 - Standard I²C interface
 - Optional RDY indication for event mode operation
 - **Low power consumption:**
 - 240uA (100Hz response, Hall),
 - 55uA (100Hz response, capacitive),
 - 65uA (20Hz response, Hall)
 - 15uA (20Hz response, capacitive)
 - 5uA (5Hz response, capacitive)
 - Supply Voltage: 2.0V to 3.6V
- *Optimal conditions

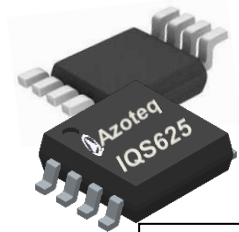

TSSOP-8
Representations only, not actual markings

Applications

- Anemometer
- Dial or Selector knob
- Mouse wheel
- Measuring wheel
- Digital angle gauge
- Speedometer for bicycle

Available Packages	
T _A	TSSOP(3x6.4)-8
-20°C to 85°C	IQS625-3yy



Contents

LIST OF ABBREVIATIONS	4
1. INTRODUCTION	5
1.1 PROXFUSION®	5
1.2 PACKAGING AND PIN-OUT	5
1.3 REFERENCE SCHEMATIC	5
1.4 SENSOR CHANNEL COMBINATIONS	6
1.5 PROXFUSION® SENSITIVITY	6
2. CAPACITIVE SENSING	7
2.1 INTRODUCTION	7
2.2 CHANNEL SPECIFICATIONS	7
2.3 HARDWARE CONFIGURATION	8
2.4 REGISTER CONFIGURATION	8
2.5 SENSOR DATA OUTPUT AND FLAGS	9
3. HALL-EFFECT SENSING	10
3.1 INTRODUCTION TO HALL-EFFECT SENSING	10
3.2 CHANNEL SPECIFICATIONS	10
3.3 HARDWARE CONFIGURATION	11
3.4 REGISTER CONFIGURATION	11
3.5 SENSOR DATA OUTPUT AND FLAGS	12
3.6 IQS625 INTERVAL UI	12
3.7 IQS625 EXAMPLE	14
3.8 IQS625 WHEEL WAKE PRELOAD (0x7C)	15
3.9 IQS625 EVENT MODE OPTIONS	15
4. DEVICE CLOCK, POWER MANAGEMENT AND MODE OPERATION	17
4.1 DEVICE MAIN OSCILLATOR	17
4.2 DEVICE MODES	17
4.3 STREAMING AND EVENT MODE	18
4.4 SYSTEM RESET	19
5. COMMUNICATION	20
5.1 CONTROL BYTE	20
5.2 I2C READ	20
5.3 I2C WRITE	21
5.4 END OF COMMUNICATION SESSION / WINDOW	21
5.5 STOP-BIT DISABLE OPTION	21
5.6 DEVICE ADDRESS AND SUB-ADDRESSES	22
5.7 ADDITIONAL OTP OPTIONS	22
5.8 REQUEST COMMUNICATION WINDOW	23
5.9 I2C SPECIFIC COMMANDS	23
5.10 RECOMMENDED COMMUNICATION AND RUNTIME FLOW DIAGRAM	24
6. IQS625 MEMORY MAP	25
6.1 DEVICE INFORMATION	27
6.2 DEVICE SPECIFIC DATA	28
6.3 COUNT DATA	29
6.4 PROXFUSION SENSOR SETTINGS	30
6.5 TOUCH / PROXIMITY UI SETTINGS	32
6.6 HALL SENSOR SETTINGS	33
6.7 DEVICE AND POWER MODE SETTINGS	37
7. ELECTRICAL CHARACTERISTICS	41
7.1 ABSOLUTE MAXIMUM SPECIFICATIONS	41
7.2 VOLTAGE REGULATION SPECIFICATIONS	41



7.3	POWER ON-RESET/BROWN OUT	41
7.4	DIGITAL INPUT/OUTPUT TRIGGER LEVELS.....	42
7.5	CURRENT CONSUMPTIONS	43
8.	PACKAGE INFORMATION	44
8.1	TSSOP-8 PACKAGE SPECIFICATIONS.....	44
8.2	TSSOP-8 RECOMMENDED PCB FOOTPRINT	44
8.3	DEVICE MARKING AND ORDERING INFORMATION	45
8.4	TAPE AND REEL SPECIFICATION	46
8.5	MSL LEVEL (PRELIMINARY).....	47
9.	DATASHEET REVISIONS	48
9.1	REVISION HISTORY	48
10.	CONTACT INFORMATION	49
11.	APPENDICES	50
11.1	APPENDIX A: MAGNET ORIENTATION	50
11.2	APPENDIX B: MAGNET CALIBRATION	54
11.3	APPENDIX C: HALL ATI	60



List of abbreviations

PXS – ProxSense®
ATI – Automatic Tuning Implementation
LTA – Long term average
Thr – Threshold
UI – User interface
AC – Alternating current
DSP – Digital signal processing
RX – Receiving electrode
TX – Transmitting electrode
CS – Sampling capacitor
C – Capacitive
NP – Normal power
LP – Low power
ULP – Ultra low power
ACK – I²C Acknowledge condition
NACK – I²C Not Acknowledge condition
FG – Floating gate



1. Introduction

1.1 ProxFusion®

The ProxFusion® sensor series provide all the proven ProxSense® engine capabilities with additional sensors types. A combined sensor solution is available within a single platform.

1.2 Packaging and Pin-Out

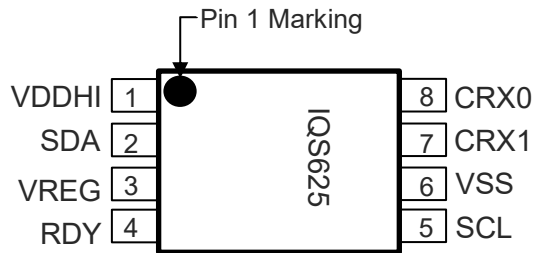

Figure 1-1 Pin out of IQS625 TSSOP (3X6.4)-8 package.

Table 1-1 IQS625 Pin-out

IQS625 Pin-out			
Pin	Name	Type	Function
1	VDDHI	Supply Input	Supply Voltage Input
2	SDA	Digital Input / Output	SDA (I ² C Data Signal)
3	VREG	Regulator Output	Internal Regulator Pin
4	RDY	Digital Output	RDY (I2C Ready interrupt signal)
5	SCL	Digital Input / Output	SCL (I ² C Clock Signal)
6	VSS	Supply Input	Ground Reference
7	CRX1	Analogue	Sense Electrode 1
8	CRX0	Analogue	Sense Electrode 0

1.3 Reference schematic

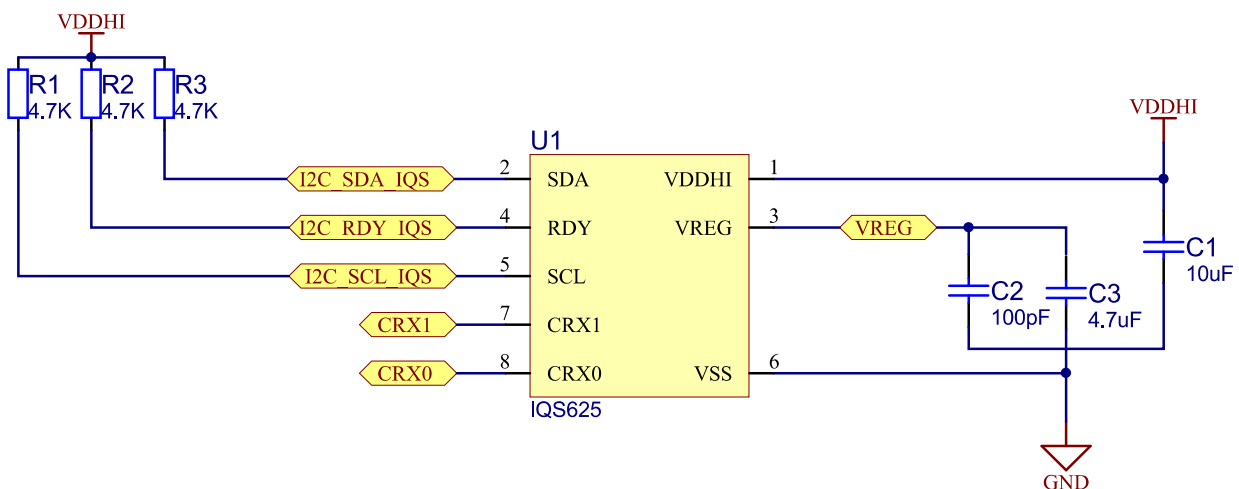

Figure 1-2 IQS625 reference schematic



1.4 Sensor channel combinations

The table below summarizes the IQS625's sensor and channel associations.

Table 1-2 Sensor - channel allocation

Sensor type	CH0	CH1	CH2	CH3	CH4	CH5
Discreet Self Capacitive	○	○				
Hall effect rotary UI			● 1 st plate Positive	● 1 st plate Negative	● 2 nd plate Positive	● 2 nd plate Negative

Key:

- Optional implementation
- Fixed use for UI

1.5 ProxFusion® Sensitivity

The measurement circuitry uses a temperature stable internal sample capacitor (C_s) and internal regulated voltage (V_{REG}). Internal regulation provides for more accurate measurements over temperature variation. The size of the sample capacitor can be decreased to increase sensitivity on the capacitive channels of the IQS625.

$$Sensitivity \propto \frac{1}{C_s}$$

The Automatic Tuning Implementation (ATI) is a sophisticated technology implemented on the ProxFusion® series devices. It allows for optimal performance of the devices for a wide range of sense electrode capacitances, without modification or addition of external components. The ATI functionality ensures that sensor sensitivity is not affected by external influences such as temperate, parasitic capacitance and ground reference changes.

The ATI process adjusts three values (Coarse multiplier, Fine multiplier, Compensation) using two parameters (ATI base and ATI target) as inputs. A 10-bit compensation value ensures that an accurate target is reached. The base value influences the overall sensitivity of the channel and establishes a base count from where the ATI algorithm starts adding compensation. A rough estimation of sensitivity can be calculated as:

$$Sensitivity \propto \frac{Target}{Base}$$

As seen from this equation, the sensitivity can be increased by either increasing the Target value or decreasing the Base value. A lower base value will typically result in lower multipliers and more compensation would be required. It should, however, be noted that a higher sensitivity will yield a higher noise susceptibility. Refer to [Appendix B](#) and [Appendix C](#) for more information on Hall ATI.



2. Capacitive sensing

2.1 Introduction

Building on the previous successes from the ProxSense® range of capacitive sensors, the same fundamental sensor engine has been implemented in the ProxFusion® series.

2.2 Channel specifications

The IQS625 provides a maximum of 2 channels available to be configured for capacitive sensing. Each channel can be setup separately using the channel's associated settings registers.

Table 2-1 Capacitive sensing - channel allocation

Sensor type	CH0	CH1	CH2	CH3	CH4	CH5
Discreet Self Capacitive	○	○				

Key:

Optional implementation

- Optional implementation
- Fixed use for UI

2.3 Hardware configuration

In the table below are two options of configuring sensing (Rx) electrodes.

Table 2-2 Capacitive hardware description

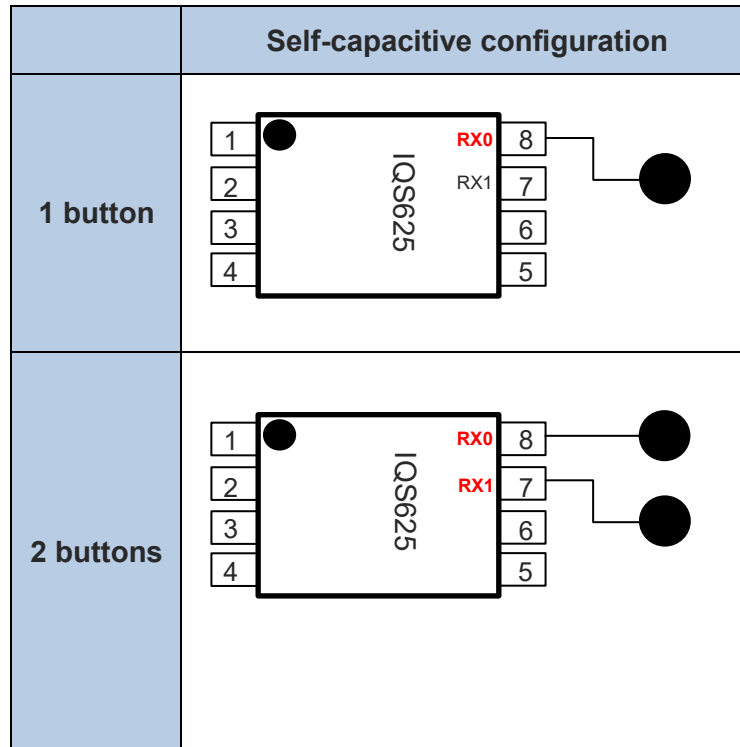

2.4 Register configuration

2.4.1 Registers to configure for the capacitive sensing:

Table 2-3 Capacitive sensing settings registers

Address	Name	Description	Recommended setting
0x40, 0x41	Ch0/Ch1 ProxFusion Settings 0	Sensor mode and configuration of each channel.	Sensor mode should be set to capacitive mode An appropriate RX should be chosen and no TX
0x42	Ch0&Ch1 ProxFusion Settings 1	Global settings for the ProxFusion sensors	None
0x43, 0x44	Ch0/Ch1 ProxFusion Settings 2	ATI settings for ProxFusion sensors	ATI target should be more than ATI base to achieve an ATI
0x45	Ch0&Ch1 ProxFusion Settings 3	Additional Global settings for ProxFusion sensors	AC filter should be enabled
0x50, 0x52	Proximity threshold	Proximity Threshold for UI	Preferably more than touch threshold
0x51, 0x53	Touch threshold	Touch Threshold for UI	None



2.4.2 Proximity Thresholds

A proximity threshold for both channels can be selected for the application, to obtain the desired proximity trigger level. The proximity threshold is selectable between 1 (most sensitive) and 255 (least sensitive) counts. These threshold values (i.e. 1-255) are specified in Counts (CS) in the [Ch0 Proximity threshold \(0x50\)](#) and [Ch1 Proximity threshold \(0x51\)](#) registers for the discreet button UI.

2.4.3 Touch Thresholds

A touch threshold for each channel can be selected by the designer to obtain the desired touch sensitivity and is selectable between 1/256 (most sensitive) to 255/256 (least sensitive). The touch threshold is calculated as a fraction of the Long-Term Average (LTA) given by,

$$T_{THR} = x/256 \times LTA$$

With lower target values (therefore lower LTA's) the touch threshold will be lower and vice versa.

Individual touch thresholds can be set for each channel, by writing to the [Ch0 Touch threshold \(0x51\)](#) and [Ch1 Touch threshold \(0x53\)](#) for the discreet button UI.

2.4.4 Example code:

Example code for an Arduino Uno can be downloaded at:

www.azoteq.com//images/stories/software/IQS62x_Demo.zip

2.5 Sensor data output and flags

The following register should be monitored by the master to detect capacitive sensor output.

- a) The [Proximity/Touch UI Flags \(0x11\)](#) provide more detail regarding the outputs. A proximity and touch output bit for each channel 0 and 1 is provided in the Proximity/Touch UI Flags register.

Proximity/Touch UI Flags (0x11)								
Bit Number	7	6	5	4	3	2	1	0
Data Access	Read							
Name			Chan 1 Touch out	Chan 0 touch out			Chan 1 proximity out	Chan 0 proximity out

Bit definitions:

- Bit 5: Channel 1 touch indicator:
 - 0: Channel 1 delta below touch threshold
 - 1: Channel 1 delta above touch threshold
- Bit 4: Channel 0 touch indicator:
 - 0: Channel 0 delta below touch threshold
 - 1: Channel 0 delta above touch threshold
- Bit 1: Channel 1 Proximity indicator:
 - 0: Channel 1 delta below proximity threshold
 - 1: Channel 1 delta above proximity threshold
- Bit 0: Channel 0 Proximity indicator:
 - 0: Channel 0 delta below proximity threshold
 - 1: Channel 0 delta above proximity threshold



3. Hall-effect sensing

3.1 Introduction to Hall-effect sensing

The IQS625 has two internal Hall-effect sensing plates (on die). No external sensing hardware is required for Hall-effect sensing.

The Hall-effect sensor measures the generated voltage difference across the plate, which can be modelled as a Wheatstone bridge. The voltage difference is converted to a current using an operational amplifier in order to be measured by the same ProxSense® sensor engine.

Advanced digital signal processing is performed to provide sensible output data.

- Calculates absolute position in intervals
- Auto calibration attempts to linearize degrees output on the fly
- Differential Hall-Effect sensing:
 - Removes common mode disturbances

3.2 Channel specifications

Channels 2 to 5 are dedicated to Hall-effect sensing. Channel 2 & 4 performs the positive direction measurements while channel 3 & 5 handle all measurements in the negative direction. Differential data is obtained from these four channels. This differential data is used as input data to calculate the output angle of the Hall-effect rotation UI. Channel 2 & 3 is used for the one plate and channel 4 & 5 for the second plate.

Table 3-1 Hall-effect sensor – channel allocation

Mode	CH0	CH1	CH2	CH3	CH4	CH5
Hall rotary UI			• 1 st plate Positive	• 1 st plate Negative	• 2 nd plate Positive	• 2 nd plate Negative

Key:

- - Optional implementation
- - Fixed use for UI

3.3 Hardware configuration

Rudimentary hardware configurations. For more detail and alternative placement options, refer to [Appendix A](#).

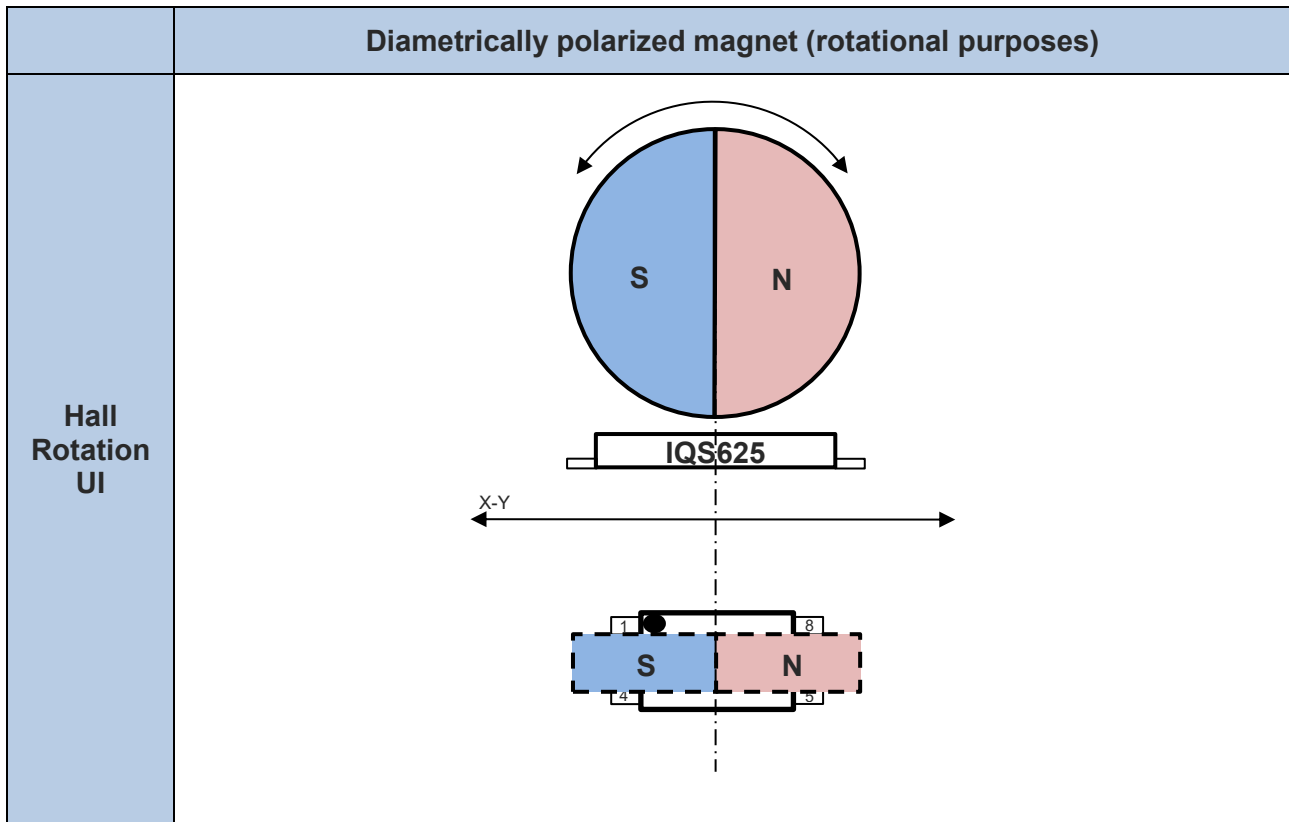

3.4 Register configuration

For more detail on the setup of the IQS625 refer to [Appendix B](#).

Table 3-2 Hall sensing settings registers

Address	Name	Description	Recommended setting
0x70	Hall Rotation UI Settings	Hall wheel UI settings	Hall UI should be enabled for degree output; enable Auto Calibration
0x71	Hall sensor settings	Auto ATI and charge frequency settings	Auto ATI should be enabled for temperature drift compensation
0x72,0x73	Hall ATI Settings ¹	Hall channels ATI settings	ATI Target should be more than base
0x78	Hall ratio Settings	Invert Direction setting for Hall UI	None
0x79	Sin(phase) constant	Sin phase calibration value	Calculate this value using the GUI or the calculations in the Appendix A

¹ Refer to the [errata](#) and [Appendix B](#)



0x7A	Cos(phase) constant	Cos phase calibration value	Calculate this value using the GUI or the calculations in the Appendix A
0x7B	Wheel Filter Beta	Degree filter value	Adjust filter value based on the amount of noise on the degree value
0x7C	Wheel Wake Preload	Wheel wakeup settings	Use default values
0x7D	Interval UI Divider	Divider for filtered degree values	Depending on the application (should be equal or greater than 10)
0x7E,0x7F	Wheel Offset	Wheel offset from zero position	Can be used for accurate intervals

3.4.1 Example code:

Example code for an Arduino Uno can be downloaded at:

www.azoteq.com//images/stories/software/IQS62x_Demo.zip

For ARM mbed resources refer to:

<https://os.mbed.com/components/IQS625/>

3.5 Sensor data output and flags

- a) The [Interval Number \(0x12\)](#) An 8-bit value for the current interval number can be read from this register. The interval size is set in the [Interval UI Divider \(0x7D\)](#) register.

Interval Number (0x12)								
Bit Number	7	6	5	4	3	2	1	0
Data Access	Read/Write							
Name	Current Interval Number							

Bit definitions:

- Bit 7-0: Current interval number (0 to $360^\circ / (\text{Interval UI Divider} - 1)$)

3.6 IQS625 Interval UI

The IQS625 offers an on-chip interval UI specifically designed for applications with discreet mechanical intervals or reduced resolution requirements.

3.6.1 Interval UI Features

- Adjustable interval size (10°-180°)
- The wheel can be zeroed at startup
- Adjustable wheel offset value
- An event is generated for changes to the Interval Number Register (0x18)



3.6.2 Interval UI Settings Registers

Hall Rotation UI Settings (0x70)								
Bit Number	7	6	5	4	3	2	1	0
Data Access	Read/Write							
Name	Hall Wheel UI disable	Interval UI disable	Zero Wheel	Hall Wheel Event disable	Interval Event Disable	Auto calibration	-	Wheel wakeup
UI Setting	0	0	0	1	0	1	-	0

Bit definitions:

- Bit 5: Zero Wheel angle
 - 1: Zero angle, automatically cleared by firmware
- Bit 3: Interval UI Event disable
 - 0: Event UI is enabled
 - 1: Event UI is disabled

Interval UI Divider (0x7D)								
Bit Number	7	6	5	4	3	2	1	0
Data Access	Read/Write							
Name	Interval size in degrees							
Default	3							

Bit definitions:

- Bit 7-0: Interval size in degrees ($\geq 10^\circ$ and $\leq 180^\circ$)

Note that the Interval UI Divider needs to be changed from the default to $\geq 10^\circ$ and ≤ 180 during setup.

Wheel Offset (0x7E-0x7F)																
Bit Number	15	14	13	12	11	10	9	8	7	6	5	4	3	2	1	0
Data Access	Read															
Name	Wheel Offset High Byte								Wheel Offset Low Byte							
Default	0															

Bit definitions:

- 0-360: Wheel offset in degrees

3.6.3 Interval UI Output Register

Interval Number ¹ (0x12)								
Bit Number	7	6	5	4	3	2	1	0
Data Access	Read/Write							
Name	Current Interval Number							

Bit definitions:

- Bit 7-0: Current interval number (0 to $360^\circ / (\text{Interval UI Divider}) - 1$)

3.7 IQS625 Example

Figure 3-1 illustrates an example wheel with 10 intervals. The IQS625 can be configured to generate an event on each interval. Configure the following registers for setup:

1. Disable Hall Wheel Event and Enable Interval Event in Hall Rotation Settings (0x70)
 - Write 0x14 to register 0x70
2. Set Interval UI Divider (0x7D) to 36D ($360^\circ/36^\circ = 10$ intervals)
 - Write 0x24 to register to 0x7D
3. If required, the wheel can be zeroed at startup in Hall Rotation UI Settings (0x70)
 - Set Bit5 in 0x70
4. The interval register will increment every 36 degrees. If the wheel is zeroed using discrete mechanical intervals (Figure 4-1), half an interval should be added to the Wheel Zero Offset (0x7E-0x7F). With this offset, the interval register should increment when the wheel has moved half of the interval as shown by B in Figure 3-1.
5. Enable Event Mode in General System Settings (0xD0)
 - Set Bit5 in 0xD0
6. The interval can be read from the Interval Number (0x12) register.

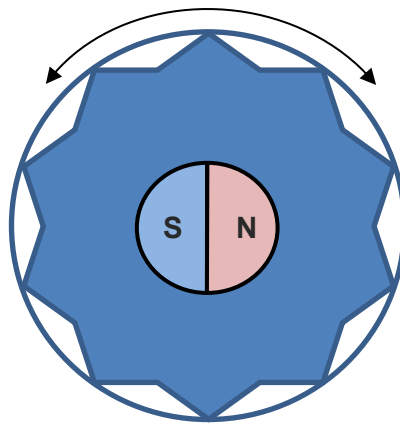

Figure 3-1: Discrete Mechanical Intervals

A 1-degree hysteresis is applied in the direction of rotation, resulting in two degrees of hysteresis at the interval change. This reduces the influence of jitter. In Figure 3-2, the interval will increase when point C is reached and will only decrease when the wheel moves back to point A. In this example A = 35° ; B = 36° ; C = 37° .

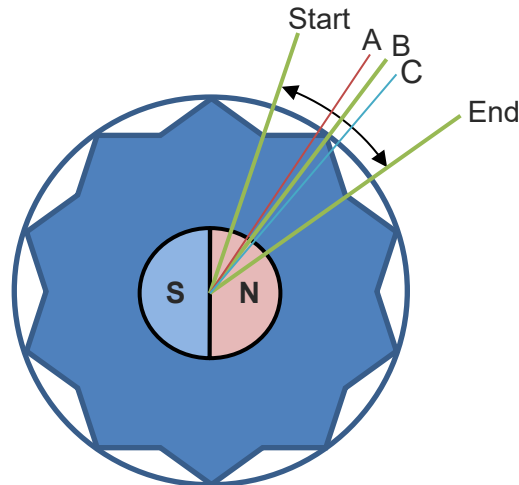

Figure 3-2: Interval UI Hysteresis

3.8 IQS625 Wheel Wake Preload (0x7C)

This register was added to improve performance. This register is compared to the Movement counter/timer (0x8F) register. The wheel will wake up if the counter value reaches the counter threshold value before the timer reaches 0. The timer in register 0x8F will count down from the value set in the **Wheel Wake Timer Preload**. The **Counter Threshold** is the amount of degrees the wheel has to move before an event is generated for movement.

The **Wheel Wake Timer Preload** can also be set to zero. In this mode the wheel will wake up if the wheel has moved the amount of degrees specified in the **Counter Threshold**. When the wheel is awake, 31 will be loaded in the **Wheel Wake Timer Preload**.

3.9 IQS625 Event Mode Options

The IQS625 provides three event mode options, these are:

1. Touch on Wheel Wakeup enabled (Bit0, 0x70)

- The device wakes up from the low-power modes when there is a touch on Ch0.
- In normal power mode events are only generated when there is a touch on Ch0. Ready events will be continuously generated as long as there is a touch on Ch0. If Touch on Wheel is enabled Interval and Hall Wheel Events are ignored.

2. Interval Event (Bit3, 0x70)

- The device wakes up from low-power modes when the wheel increment or decrement the interval register.
- Ready events are generated in normal power mode when the interval changes. If Interval Events and Hall Wheel Events (below) are enabled the IC will respond to Hall Wheel Events.

3. Hall Wheel Event (Bit4, 0x70)

- The device wakes up based on the conditions described in Section 3.8. The wheel will wake up if the counter value reaches the counter threshold value before the timer reaches 0.



- Events are generated on the same condition when the device is in low power mode. If Hall Wheel Events and Interval Events are enabled the IC will respond to Hall Wheel Events.

The device can also be set to **Stream in Normal Power (Bit5, 0xD9)**. With this bit set the device will wake up from either of the selected modes above. Events will be generated based on the Normal Power Report Rate during Normal Power mode. The device will stop streaming when low-power mode is entered.

Table 3-3: Hall Rotation UI Settings

	Hall Rotation UI Settings (0x70)
Touch on Wheel Wakeup	0x1D
Interval Event	0x14
Hall Wheel Event	0x0C

If all of these modes are disabled, there will be no events generated for wheel movements.



4. Device clock, power management and mode operation

4.1 Device main oscillator

The IQS625 has a **16MHz** main oscillator (default enabled) to clock all system functionality.

An option exists to reduce the main oscillator to 8MHz. This will result in charge transfers to be slower by half of the default implementations.

To set this option:

- As a software setting – Set the [General System Settings \(0xD0\)](#): bit4 = 1, via an I²C command.
- As a permanent setting – Set the [OTP option](#) in FG Bank 0: bit2 = 1, using Azoteq USBProg program.

The ProxFusion® channels charges at half of the main oscillator frequency. Therefore the frequency multiplier selected in [Ch0&1 ProxFusion Settings 1 \(0x42; bit 4-5\)](#) and [Hall sensor settings \(0x71; bit 4-5\)](#) is multiplied by half of the main oscillator frequency.

4.2 Device modes

The IQS625 supports the following modes of operation;

- **Normal mode** (Fixed report rate)
- **Low Power mode** (Reduced report rate, no UI execution)
- **Ultra-Low Power mode** (Only channel 0 is sensed for a prox)
- **Halt Mode** (Suspended/disabled)

Note: Auto modes must be disabled to enter or exit halt mode.

The device will automatically switch between the different operating modes by default. However, this Auto mode feature may be disabled by setting the Disable Auto Modes bit ([Power Mode Settings 0xD2; bit 5](#)) to confine device operation to a specific power mode. The Power Mode bits ([Power Mode Settings 0xD2; bit 3-4](#)) can then be used to specify the desired mode of operation.

4.2.1 Normal mode

Normal mode is the fully active sensing mode to function at a fixed report rate specified in the [Normal Mode report rate \(0xD3\)](#) register. This 8-bit value is adjustable from 0ms – 255ms in intervals of 1ms.

4.2.2 Low power mode

Low power mode is a reduced sensing mode where all channels are sensed but no UI code are executed. The sample rate can be specified in the [Low Power Mode report rate \(0xD4\)](#) register. The 8-bit value is adjustable from 0ms – 255ms in intervals of 1ms. Reduced report rates also reduce the current consumed by the sensor.

4.2.3 Ultra-low power mode

Ultra-low power mode is a reduced sensing mode where only channel 0 is sensed and no other channels or UI code are executed. Set the Enable ULP Mode bit ([Power Mode Settings 0xD2; bit 6](#)) to enable use of the ultra-low power mode. The sample rate can be specified in the [Low Power Mode report rate \(0xD5\)](#) register. The 8-bit value is adjustable from 0ms – 4sec in intervals of 16ms.

When in Ultra-low power mode the IQS625 can be configured to update all channels at a specific rate defined in [Power Mode Settings \(0xD2\)](#) register. A flag will be set in the [System flags \(0x10; bit 0\)](#) register when a normal power update is performed. Wake up will occur on proximity



detection on channel 0. Ultra-low power mode will not function properly if channel 0 is not enabled.

4.2.4 Halt mode

Halt mode will suspend all sensing and will place the device in a dormant or sleep state. The device requires an I²C command from a master to explicitly change the power mode out of the halt state before any sensor functionality can continue.

4.2.5 Mode time

The mode time is specified in the [Auto Mode Timer \(0xD6\)](#) register. The 8-bit value is adjustable from 0ms – 2 min in intervals of 500ms.

4.3 Streaming and event mode:

Streaming mode is the default. Event mode is enabled by setting bit 5 in the [General System Settings \(0xD0\)](#) register.

4.3.1 Streaming mode

The ready is triggered every cycle and per the report rate.

4.3.2 Event mode

The ready is triggered only when an event has occurred.

The events which trigger the ready can be configured to:

- Hall wheel movement (If the hall UI is enabled)
- Touch or proximity events on channel 0 or 1
- Interval Event

Note: Both these events have built in hysteresis which filters out very slow changes.



4.4 System reset

The IQS625 device monitor's system resets and events.

- a) Every device power-on and reset event will set the Show Reset bit in the [System Flags \(0x10; bit 7\)](#) register and the master should explicitly clear this bit by setting the Ack Reset bit in the [General System Settings \(0xD0; bit 6\)](#) register.
- b) The system events will also be indicated with the Event bit in the [System Flags \(0x10; bit 1\)](#) register if any system event occur such as a reset. This event will continuously trigger until the reset has been acknowledged.

5. Communication

The **IQS625** device interfaces to a master controller via a 3-wire (SDA, SCL and RDY) serial interface bus that is I²C™ compatible with a maximum communication speed of 400 kHz. The communications interface of the IQS625 supports the following:

- Streaming data as well as event mode.
- The master may address the device at any time. If the IQS625 is not in a communication window, the device returns an ACK after which clock stretching is induced until a communication window is entered. Additional communication checks are included in the main loop in order to reduce the average clock stretching time.
- The provided interrupt line (RDY) is push-pull active low on IQS625 and open-drain active low on IQS625. The RDY indicates a communication window.

5.1 Control Byte

The Control byte indicates the 7-bit device address (44H default) and the Read/Write indicator bit. The structure of the control byte is shown in Figure 5-1.

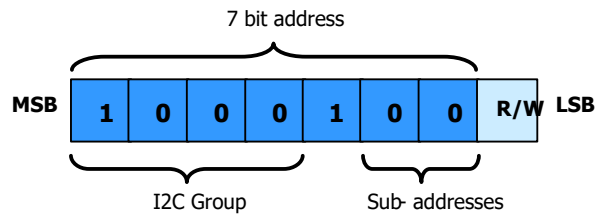

Figure 5-1 IQS625 Control Byte

The I²C device has a 7 bit Slave Address (default 0x44H) in the control byte. To confirm the address, the software compares the received address with the device address. Sub-address values can be set by OTP programming options.

5.2 I2C Read

To read from the device a *current address read* can be performed. This assumes that the address-command is already setup as desired.



Figure 5-2 Current Address Read

If the address-command must first be specified, then a *random read* must be performed. In this case a WRITE is initially performed to setup the address-command, and then a repeated start is used to initiate the READ section.

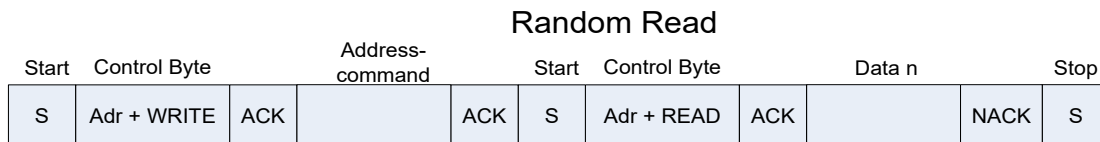

Figure 5-3 Random Read



5.3 I2C Write

To write settings to the device a *Data Write* is performed. Here the Address-Command is always required, followed by the relevant data bytes to write to the device.

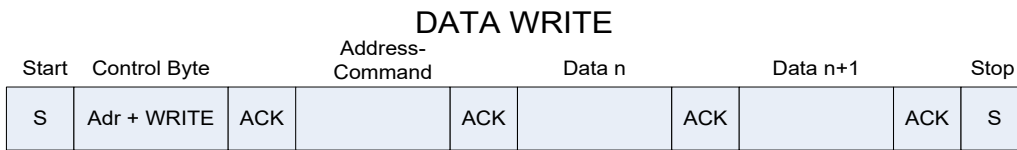

Figure 5-4 I²C Write

5.4 End of Communication Session / Window

Similar to other Azoteq I²C devices, to end the I²C communication session, a STOP command is given. When sending numerous read and write commands in one communication cycle, a repeated start command must be used to stack them together (since a STOP will jump out of the communication window, which is not desired).

The STOP will then end the communication, and the IQS625 will return to process a new set of data. Once this is obtained, the communication window will again become available (RDY set LOW).

5.5 Stop-bit disable option

The IQS625 offer:

- an [I²C settings](#) register (0xD9) specifically added for stop-bit disable functionality,
- as well as a [RDY timeout period](#) register (0xD8) in order to set the required timeout period for termination of any communication windows (RDY = Low) if no I²C activity is present on SDA and SCL pins.

Customers using an MCU with a binary serial-encoder peripheral which is not fully I²C compatible (but provide some crude serial communication functions) can use this option to configure the IQS625 so that any auto generated stop command from the serial peripheral can be ignored by the IQS625 I²C hardware. This will restrict the IQS625 from immediately exiting a communication window during event mode (reduced communication only for events) until all required communication has been completed and a stop command can correctly be transmitted. Please refer to the figures below for serial data transmission examples.

Please note:

1. Stop-bit disable and enable must be performed at the beginning and end of a communication window. The first and last I²C register to be written to ensure no unwanted communication window termination.
2. Leaving the Stop-bit disabled will result in successful reading of registers but will not execute any commands written over I²C in a communication window being terminated after a RDY timeout and with no IQS recognised stop command.
3. The default RDY timeout period for IQS625 is purposefully long (10.24ms) for slow responding MCU hardware architectures. Please set this register according to your requirements/preference.

Stop-bit Disable

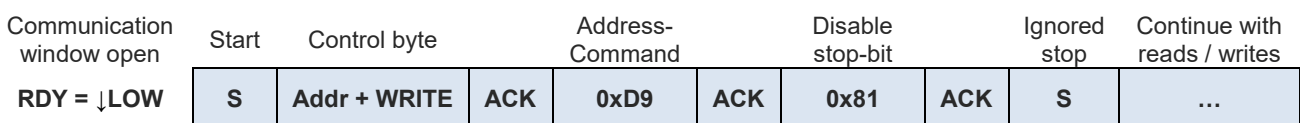

Figure 5-5 I²C Stop-bit Disable



Stop-bit Enable

Reads / Writes Finished	Start	Control byte	Address-Command		Enable stop-bit	Stop	Communication window closed		
...	S	Addr + WRITE	ACK	0xD9	ACK	0x01	ACK	S	RDY = ↑HIGH

Figure 5-6 I²C Stop-bit Enable

5.6 Device address and sub-addresses

The default device address is **0x44 = DEFAULT_ADDR**.

Alternative sub-address options are definable in the following one-time programmable bits:
OTP Bank0 (bit3; 0; bit1; bit0) = SUB_ADDR_0 to SUB_ADDR_7

- a) Default address: **0x44 = DEFAULT_ADDR OR SUB_ADDR_0**
- b) Sub-address: **0x45 = DEFAULT_ADDR OR SUB_ADDR_1**
- c) Sub-address: **0x46 = DEFAULT_ADDR OR SUB_ADDR_2**
- d) Sub-address: **0x47 = DEFAULT_ADDR OR SUB_ADDR_3**
- e) Sub-address: **0x4C = DEFAULT_ADDR OR SUB_ADDR_4**
- f) Sub-address: **0x4D = DEFAULT_ADDR OR SUB_ADDR_5**
- g) Sub-address: **0x4E = DEFAULT_ADDR OR SUB_ADDR_6**
- h) Sub-address: **0x4F = DEFAULT_ADDR OR SUB_ADDR_7**

5.7 Additional OTP options

All one-time-programmable device options are located in FG bank 0.

Floating Gate Bank0							
Bit Number	7	6	5	4	3	2	1 0
Name	-	Comms ATI	-	-	Sub address 2	8MHz	Sub address 0-1
Default	-	0	-	-	0	0	0 0

Bit definitions:

- Bit 6: Comms mode during ATI
 - 0: No streaming events are generated during ATI
 - 1: Comms continue as setup regardless of ATI state.
- Bit 2: Main Clock frequency selection
 - 0: Run FOSC at 16MHz
 - 1: Run FOSC at 8MHz
- Bit 0,1,3: I2C sub-address
 - I2C address = 0x44

All calibration data are located in FG bank 3 for IQS625 IC's.

Floating Gate Bank3								
Bit Number	7	6	5	4	3	2	1 0	
Name	-				Hall Plate Calibration Data			
Default	-				15-1			

Bit definitions:

- Bit 3-0: Hall Plate Calibration Data
 - 15-1: The calibration bin of the IC

Please refer to Appendix B: Magnet calibration for information regarding hall plate calibration.



5.8 Request Communication Window

The master or host MCU has the capability to request a communication window at any time, by writing the device address to the IQS625. The communication window will open directly following the current conversion cycle.

5.9 I²C Specific Commands

5.9.1 Show Reset

After start-up, and after every reset event, the “Show Reset” flag will be set in the [System Flags register \(0x10H; bit 7\)](#).

The “Show Reset” bit can be read to determine whether a reset has occurred on the device (it is recommended to be continuously monitored). This bit will be set '1' after a reset.

The “Show Reset” flag will be cleared (set to '0') by writing a '1' into the “Ack reset” bit in the [General system settings register \(0xD0; bit 6\)](#) . A reset will typically take place if a timeout during communication occurs.

5.9.2 I²C Timeout

If no communication is initiated from the master/host MCU within the first t_{COMMS} ($t_{COMMS} = 2.038$ ms default) of the RDY line indicating that data is available (i.e. RDY = low), the device will resume with the next cycle of charge transfers and the data from the previous conversions will be lost. The [RDY timeout period](#) register (0xD8) can be adjusted on IQS625. There is also a timeout (t_{I2C}) that cannot be disabled, for when communication has started but not been completed, for example when the bus is being held by another device ($t_{I2C} = 33$ ms).

5.10 Recommended communication and runtime flow diagram

The following is a basic master program flow diagram to communicate and handle the device. It addresses possible device events such as output events, ATI and system events (resets).

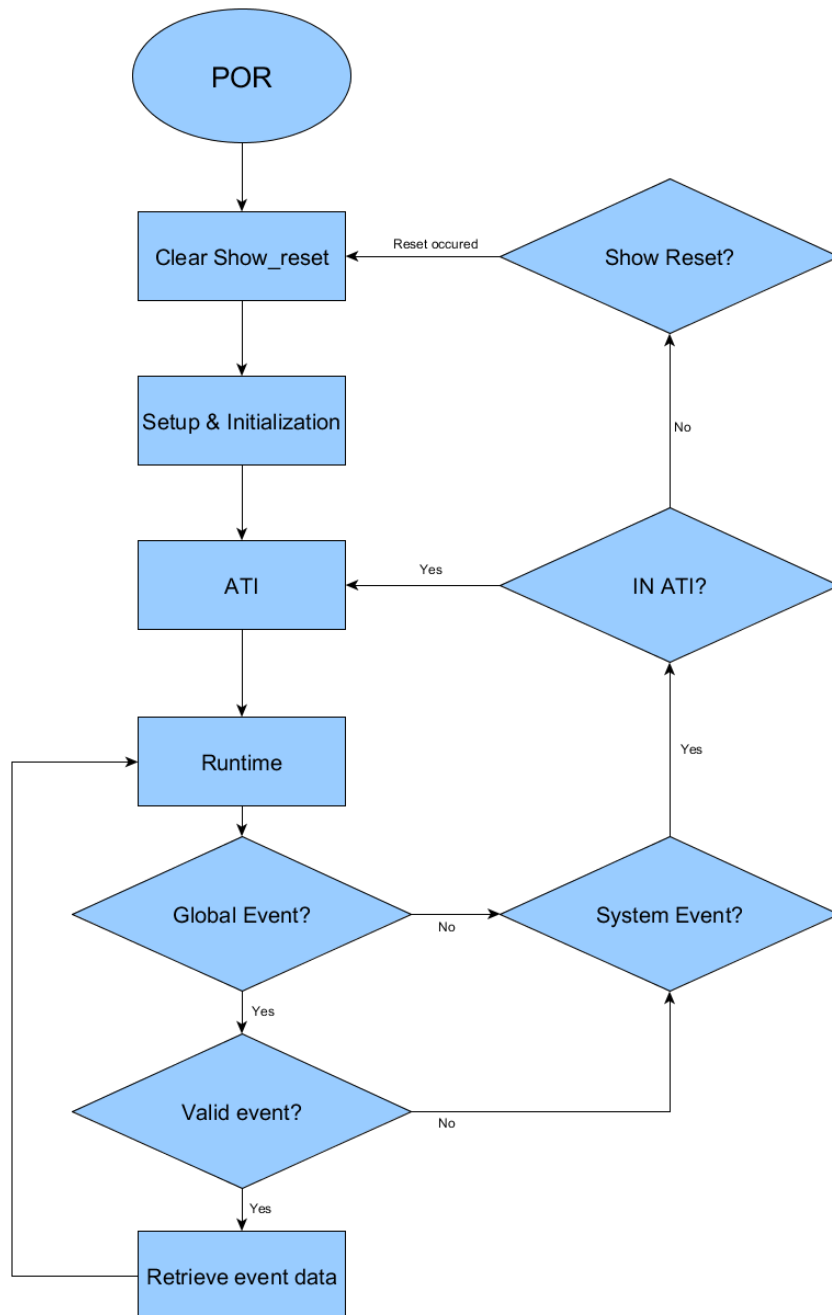

Figure 5-7 Master command structure and runtime event handling flow diagram

It is recommended that the master verifies the status of the [System Flags \(0x10\)](#) bits to identify events and resets. Detecting either one of these should prompt the master to the next steps of handling the IQS625.

Streaming mode communication is used for detail sensor evaluation during prototyping and/or development phases. Event mode communication is recommended for runtime use of the IQS625.



6. IQS625 Memory map

Table 6-1 IQS625 Register map

Register Address	Group	Register Name
0x00	Device Information	Product Number
0x01		Software Number
0x02		Hardware Number
0x10	Device Specific Data	System Flags
0x11		Proximity/Touch UI Flags
0x12		Interval Number Output
0x20	Count Data	CH0 CS Low
0x21		CH0 CS High
0x22		CH1 CS Low
0x23		CH1 CS High
0x24		CH2 CS Low
0x25		CH2 CS High
0x26		CH3 CS Low
0x27		CH3 CS High
0x28		CH4 CS Low
0x29		CH4 CS High
0x2A		CH5 CS Low
0x2B		CH5 CS High
0x30		CH0 LTA Low
0x31		CH0 LTA High
0x32	CH1 LTA Low	
0x33	CH1 LTA High	
0x40	ProxFusion sensor settings	Ch0 ProxFusion Settings 0
0x41		Ch1 ProxFusion Settings 0
0x42		Ch0&1 ProxFusion Settings 1
0x43		Ch0 ProxFusion Settings 2
0x44		Ch1 ProxFusion Settings 2
0x45		Ch0&1 ProxFusion Settings 3
0x46		Ch0 Compensation
0x47	Ch1 Compensation	
0x48	ProxFusion sensor settings	Ch0 Multipliers
0x49		Ch1 Multipliers



Register Address	Group	Register Name
0x50	Touch / Proximity UI settings	Ch0 Proximity threshold
0x51		Ch0 Touch threshold
0x52		Ch1 Proximity threshold
0x53		Ch1 Touch threshold
0x54		UI Halt period
0x70	HALL Sensor Settings	Hall Rotation UI Settings
0x71		Hall Sensor Settings
0x72		Ch2&3 Hall ATI Settings
0x73		Ch4&5 Hall ATI Settings
0x74		Ch2&3 Compensation
0x75		Ch4&5 Compensation
0x76		Ch2&3 Multipliers
0x77		Ch4&5 Multipliers
0x78		Hall Ratio Settings
0x79		Sin Constant
0x7A		Cos Constant
0x7B		Wheel Filter Beta
0x7C		Wheel Wake Preload
0x7D		Interval UI Divider
0x7E		Wheel Offset (Low byte)
0x7F	Wheel Offset (High byte)	
0xD0	Device and Power mode Settings	General System Settings
0xD1		Active Channels
0xD2		Power Mode Settings
0xD3		Normal mode report rate
0xD4		Low power mode report rate
0xD5		Ultra-low power mode report rate
0xD6		Auto Mode time
0xD8		RDY Timeout Period
0xD9		I2C Settings



6.1 Device Information

6.1.1 Product Number

Product Number (0x00)								
Bit Number	7	6	5	4	3	2	1	0
Data Access	Read							
Name	Device Product Number							

Bit definitions:

- Bit 0-7: Device Product Number = D'78'

6.1.2 Software Number

Software Number (0x01)								
Bit Number	7	6	5	4	3	2	1	0
Data Access	Read							
Name	Device Software Number							

Bit definitions:

- Bit 0-7: Device Software Number = D'11'

6.1.3 Hardware Number

Hardware Number (0x02)								
Bit Number	7	6	5	4	3	2	1	0
Data Access	Read							
Name	Device Hardware Number							

Bit definitions:

- Bit 0-7: Device Hardware Number = D'130'



6.2 Device Specific Data

6.2.1 System Flags

System flags (0x10)								
Bit Number	7	6	5	4	3	2	1	0
Data Access	Read							
Name	Show Reset			Current power mode		ATI Busy	Event	NP Segment Active

Bit definitions:

- Bit 7: Reset Indicator:
 - 0: No reset event
 - 1: A device reset has occurred and needs to be acknowledged
- Bit 4-3: Current power mode indicator:
 - 00: Normal power mode
 - 01: Low power mode
 - 10: Ultra-Low power mode
 - 11: Halt power mode
- Bit 2: ATI Busy Indicator:
 - 0: No channels are in ATI
 - 1: One or more channels are in ATI
- Bit 1: Global Event Indicator:
 - 0: No new event to service
 - 1: An event has occurred and should be handled
- Bit 0: Normal Power segment indicator:
 - 0: Not performing a normal power update
 - 1: Busy performing a normal power update

6.2.2 Proximity/Touch UI Flags

Proximity/Touch UI Flags (0x11)								
Bit Number	7	6	5	4	3	2	1	0
Data Access	Read							
Name			Chan 1 Touch out	Chan 0 touch out			Chan 1 proximity out	Chan 0 proximity out

Bit definitions:

- Bit 5: Channel 1 touch indicator:
 - 0: Channel 1 delta below touch threshold
 - 1: Channel 1 delta above touch threshold
- Bit 4: Channel 0 touch indicator:
 - 0: Channel 0 delta below touch threshold
 - 1: Channel 0 delta above touch threshold
- Bit 1: Channel 1 Proximity indicator:
 - 0: Channel 1 delta below proximity threshold
 - 1: Channel 1 delta above proximity threshold
- Bit 0: Channel 0 Proximity indicator:
 - 0: Channel 0 delta below proximity threshold
 - 1: Channel 0 delta above proximity threshold



6.2.3 Interval Number

Interval Number (0x12)								
Bit Number	7	6	5	4	3	2	1	0
Data Access	Read/Write							
Name	Current Interval Number							

- Bit 7-0: Current interval number

6.3 Count Data

6.3.1 Count CS Values

Count CS values (0x20/0x21-0x2A/0x2B)																
Bit Number	15	14	13	12	11	10	9	8	7	6	5	4	3	2	1	0
Data Access	Read															
Name	Count High Byte								Count Low Byte							

Bit definitions:

- Bit 15-0: Counts
 - AC filter or raw value

6.3.2 LTA Values

LTA values (0x30/0x31-0x32/0x33)																
Bit Number	15	14	13	12	11	10	9	8	7	6	5	4	3	2	1	0
Data Access	Read															
Name	LTA High Byte								LTA Low Byte							

Bit definitions:

- Bit 15-0: LTA Values
 - LTA filter value



6.4 ProxFusion sensor settings

6.4.1 Ch0/1 ProxFusion Settings 0

Ch0/1 ProxFusion Settings 0 (0x40/0x41)								
Bit Number	7	6	5	4	3	2	1	0
Data Access	Read/Write							
Name	Sensor mode				TX select		RX select	
Default	0	0	0	0	0	0		

Bit definitions:

- Bit 7-4: Sensor mode select:
 - 0000: Self capacitive mode
- Bit 3-2: TX-select:
 - 00: TX 0 and TX 1 is disabled
- Bit 1-0: RX select:
 - 00: RX 0 and RX 1 is disabled
 - 01: RX 0 is enabled
 - 10: RX 1 is enabled
 - 11: RX 0 and RX 1 is enabled

6.4.2 Ch0&1 ProxFusion Settings 1

Ch0&1 ProxFusion Settings 1 (0x42)								
Bit Number	7	6	5	4	3	2	1	0
Data Access	Read/Write							
Name	-	CS PXS	Charge Freq	Proj bias pxs		Auto ATI Mode		
Default	0x5B							

Bit definitions:

- Bit 6: ProxFusion Sensing Capacitor size select:
 - 0: ProxFusion Sensing capacitor size is 15 pF
 - 1: ProxFusion Sensing capacitor size is 60 pF
- Bit 5-4: Charge Frequency select:
 - 00: 1/2
 - 01: 1/4
 - 10: 1/8
 - 11: 1/16
- Bit 3-2: Projected bias:
 - 00: 2.5µA / 88kΩ
 - 01: 5µA / 66kΩ
 - 10: 10µA / 44kΩ
 - 11: 20µA / 22kΩ
- Bit 1-0: Auto ATI Mode select:
 - 00: ATI Disabled
 - 01: Partial ATI (Multipliers are fixed)
 - 10: Semi Partial ATI (Coarse multipliers are fixed)
 - 11: Full ATI



6.4.3 Ch0 ProxFusion Settings 2

Ch0 ProxFusion Settings 2 (0x43)								
Bit Number	7	6	5	4	3	2	1	0
Data Access	Read/Write							
Name	ATI Base			ATI Target				
Default	0x50							

Bit definitions:

- Bit 7-6: ATI Base value select:
 - 00: 75
 - 01: 100
 - 10: 150
 - 11: 200
- Bit 5-0: ATI Target:
 - ATI Target is 6-bit value x 32

6.4.4 Ch1 ProxFusion Settings 2

Ch1 ProxFusion Settings 2 (0x44)								
Bit Number	7	6	5	4	3	2	1	0
Data Access	Read/Write							
Name	ATI Base			ATI Target				
Default	0x50							

Bit definitions:

- Bit 7-6: ATI Base value select:
 - 00: 75
 - 01: 100
 - 10: 150
 - 11: 200
- Bit 5-0: ATI Target:
 - ATI Target is 6-bit value x 32

6.4.5 Ch0&1 ProxFusion Settings 3

Ch0&1 ProxFusion Settings 3 (0x45)								
Bit Number	7	6	5	4	3	2	1	0
Data Access	Read/Write							
Name	-	CS Div	Two sided PXS	-	LTA Beta		ACF Beta	
Default	0x00							

Bit definitions:

- Bit 6: CS divider
 - 0: Sampling capacitor divider disabled
 - 1: Sampling capacitor divider enabled
- Bit 5: Two sided ProxFusion Sensing
 - 0: Bidirectional detection disabled
 - 1: Bidirectional detection enabled
- Bit 3-2: LTA Beta 0
 - 00: 7
 - 01: 8
 - 10: 9
 - 11: 10



- Bit 1-0: ACF Beta 1
 - 00: 1
 - 01: 2
 - 10: 3
 - 11: 4

6.4.6 Ch0/Ch1 Compensation

Ch0/Ch1 Compensation (0x46,0x47)								
Bit Number	7	6	5	4	3	2	1	0
Data Access	Read/Write							
Name	Compensation (7-0)							

Bit definitions:

- Bit 7-0: 0-255: Lower 8 bits of the Compensation Value

Register addresses:

- 0x46: Channel 0 Lower 8 bits of the Compensation Value
- 0x47: Channel 1 Lower 8 bits of the Compensation Value

6.4.7 Ch0/Ch1 Multipliers values

Ch0/1 Multipliers values(0x48/0x49)									
Bit Number	7	6	5	4	3	2	1	0	
Data Access	Read/Write								
Name	Compensation (9-8)		Coarse multiplier			Fine multiplier			

Bit definitions:

- Bit 7-6: Compensation upper two bits
 - 0-3: Upper 2-bits of the Compensation value.
- Bit 5-4: Coarse multiplier Selection:
 - 0-3: Coarse multiplier selection
- Bit 3-0: Fine Multiplier Selection:
 - 0-15: Fine Multiplier selection

Register addresses:

- 0x48: Channel 0 Multipliers Value
- 0x49: Channel 1 Multipliers Value

6.5 Touch / Proximity UI settings

6.5.1 Ch0/1 Proximity/touch threshold

Proximity/touch threshold Ch0/1(0x50-0x53)								
Bit Number	7	6	5	4	3	2	1	0
Data Access	Read/Write							
Name	Threshold							

Bit definitions:

- Bit 7-0: Proximity and touch thresholds:
If a difference between the LTA and counts value would exceed this threshold the appropriate event would be flagged (either Touch or Proximity Event).

Register addresses:

- 0x50 Channel 0 Proximity Threshold Value



- 0x51 Channel 0 Touch Threshold Value
- 0x52 Channel 1 Proximity Threshold Value
- 0x53 Channel 1 Touch Threshold Value

6.5.2 UI Halt period

UI Halt period (0x54)								
Bit Number	7	6	5	4	3	2	1	0
Data Access	Read/Write							
Name	UI Halt period							
Default	0x28 = 20 sec							

Bit definitions:

- Bit 7-0: Halt time in 500 ms ticks

6.6 HALL Sensor Settings

6.6.1 Hall Rotation UI Settings

Hall Rotation UI Settings (0x70)								
Bit Number	7	6	5	4	3	2	1	0
Data Access	Read/Write							
Name	Hall Wheel UI disable	Interval UI disable	Zero Wheel	Hall Wheel Event disable	Interval Event Disable	Auto calibration	-	Wheel wakeup
Default	0	0	0	0	1	1	-	0

Bit definitions:

- Bit 7: Hall Wheel UI disable
 - 0: Hall wheel UI is enabled
 - 1: Hall wheel UI is disabled
- Bit 6: Interval UI disable
 - 0: Interval UI is enabled
 - 1: Interval UI is disabled
- Bit 5: Zero Wheel angle
 - 1: Zero angle, automatically cleared by firmware
- Bit 4: Hall Wheel UI Event disable
 - 0: Event UI is enabled
 - 1: Event UI is disabled
- Bit 3: Interval UI Event disable
 - 0: Event UI is enabled
 - 1: Event UI is disabled
- Bit 2: Auto calibration
 - 0: Auto calibration disabled
 - 1: Auto calibration enabled
- Bit 0: Wheel wakeup select
 - 0: Wheel wakeup mode disabled
 - 1: Wheel wakeup mode enabled (wakes up on Ch0 touch).



6.6.2 Hall Sensor Settings

Hall Sensor Settings (0x71)								
Bit Number	7	6	5	4	3	2	1	0
Data Access	Read/Write							
Name	ACF Enable	-	Charge Freq	-	-	Auto ATI mode Hall		
Default	0	0	0	0	0	0	1	1

Bit definitions:

- Bit 7: ACF Enable: Enable filter on the individual Hall channels¹
 - 0: Filter disabled
 - 1: Filter Enabled
- Bit 5-4: Charge Frequency: The rate at which our measurement circuit samples
 - 00: 1/2
 - 01: 1/4
 - 10: 1/8
 - 11: 1/16
- Bit 1-0: Auto ATI Mode
 - 00: ATI disabled: ATI is completely disabled
 - 01: Partial ATI: Only adjusts compensation
 - 10: Semi-Partial ATI: Only adjusts compensation and the fine multiplier.
 - 11: Full-ATI: Compensation and both coarse and fine multipliers is adjusted

6.6.3 Ch2/3, Ch4/5 Hall ATI Settings

Ch2/3, Ch4/5 Hall ATI Settings (0x72/0x73)									
Bit Number	7	6	5	4	3	2	1	0	
Data Access	Read/Write								
Name	ATI Base			ATI Target					
Default	0x73								

Register addresses:

- 0x72: Channel 2 & 3 ATI settings
- 0x73: Channel 4 & 5 ATI settings

Bit definitions:

- Bit 7-6: ATI Base value select:
 - 00: 75
 - 01: 100
 - 10: 150
 - 11: 200
- Bit 5-0: ATI Target:
 - ATI Target is 6-bit value x 32

6.6.4 Ch2/3, Ch4/5 Hall Compensation

Ch2/3, Ch4/5 Hall Compensation (0x74,0x75)								
Bit Number	7	6	5	4	3	2	1	0
Data Access	Read/Write							
Name	Compensation (7-0)							

Bit definitions:

- Bit 7-0: 0-255: Lower 8 bits of the compensation value



6.6.5 Ch2/3, Ch4/5 Hall Multipliers

Ch2/3, Ch4/5 Hall Multipliers (0x76-0x77)									
Bit Number	7	6	5	4	3	2	1	0	
Data Access	Read/Write								
Name	Compensation 9-8		Coarse Multiplier			Fine Multiplier			

Bit definitions:

- Bit 7-6: Compensation 9-8:
 - 0-3: Upper 2-bits of the compensation value
- Bit 5-4: Coarse multiplier selection
 - 0-3: Coarse multiplier selection
- Bit 3-0: Fine multiplier selection
 - 0-15: Fine multiplier selection

6.6.6 Hall Ratio Settings

Hall ratio settings (0x78)									
Bit Number	7	6	5	4	3	2	1	0	
Data Access	Read			Read/Write		Read			
Name	-	Octant flag	Y negative	-	Direction invert / Cos negative	Ratio Negative	Denominator negative	Numerator negative	

Bit definitions:

- Bit 6-5: Quadrature output for octant changes (per 45 degrees)
 - 0-3: Quadrature output
- Bit 3: Invert direction of degrees
 - 0 – Invert not active
 - 1 – Invert active
- Bit 2: Ratio negative (Used for on-chip angle calculation)
 - 0 – Ratio is positive
 - 1 – Ratio is negative
- Bit 1: Denominator negative (Used for on-chip angle calculation)
 - 0 – Denominator is positive
 - 1 – Denominator is negative
- Bit 0: Numerator negative (Used for on-chip angle calculation)
 - 0 – Numerator is positive
 - 1 – Numerator is negative

6.6.7 Sin Constant

Sin constant (0x79)								
Bit Number	7	6	5	4	3	2	1	0
Data Access	Read/Write							
Name	Sin constant							

Bit definitions:

- Bit 7-0: Sin (phase difference) x 255

6.6.8 Cos Constant

Cos constant (0x7A)								
Bit Number	7	6	5	4	3	2	1	0
Data Access	Read/Write							
Name	Cos constant							



Bit definitions:

- Bit 7-0: Cos (phase difference) x 255

Phase difference:

Phase difference measured between the signals obtained from the two Hall sensor plates. This can be calculated with a simple calibration, see [Appendix B](#).

6.6.9 Wheel Filter Beta

Wheel Filter Beta (0x7B)								
Bit Number	7	6	5	4	3	2	1	0
Data Access	Read/Write							
Name	Wheel Filter Beta							
Default	0x08							

Bit definitions:

- Bit 7-0: Initial value used during calculation of wheel filter beta.

6.6.10 Wheel Wake Preload

Wheel Wake Preload (0x7C)									
Bit Number	7	6	5	4	3	2	1	0	
Data Access	Read/Write								
Name	Counter Threshold				Timer Preload				
Default	7				31				

Bit definitions:

- Bit 7-5: Wheel Wake Counter Threshold
 - 0-7: The wheel will wake up if the counter value reaches the counter threshold value before the timer reaches 0.
- Bit 4-0: Wheel Wake Timer Preload
 - 0: Stop timer when wheel is in sleep. Load 31 when wheel is awake.
 - 1-31: Preload Value loaded into Movement Timer. The wheel will wake up if the Movement Counter value reaches the Counter Threshold value before the timer reaches 0.

6.6.11 Interval UI Divider

Interval UI Divider (0x7D)								
Bit Number	7	6	5	4	3	2	1	0
Data Access	Read/Write							
Name	Interval size in degrees							
Default	0x03							

Bit definitions:

- Bit 7-0: Interval size in degrees ($\geq 10^\circ$ and $\leq 180^\circ$)

Note that the Interval UI Divider needs to be changed from the default to $\geq 10^\circ$ and $\leq 180^\circ$ during setup.

6.6.12 Wheel Offset

Wheel Offset (0x7E-0x7F)																
Bit Number	15	14	13	12	11	10	9	8	7	6	5	4	3	2	1	0
Data Access	Read															
Name	Wheel Offset High Byte								Wheel Offset Low Byte							



Default	0x00
---------	------

Bit definitions:

- 16-bit value: Wheel offset in degrees (0°- 359°)

6.7 Device and Power Mode Settings

6.7.1 General System Settings

General System Settings (0xD0)								
Bit Number	7	6	5	4	3	2	1	0
Data Access	Read/Write							
Name	Soft reset	Ack reset	Event mode	8Mhz	Comms in ATI	Small ATI band	Redo ATI all	Do reseed
Default			0	0	0	0		

Bit definitions:

- Bit 7: Soft Reset (**Set only, will clear when done**)
 - 1 – Causes the device to perform a WDT reset
- Bit 6: Acknowledge reset (**Set only, will clear when done**)
 - 1 – Acknowledge that a reset has occurred. This event will trigger until acknowledged
- Bit 5: Communication mode select:
 - 0 – Streaming communication mode enabled
 - 1 – Event communication mode enabled
- Bit 4: Main clock frequency selection
 - 0 – Run FOSC at 16Mhz
 - 1 – Run FOSC at 8 Mhz
- Bit 3: Communication during ATI select:
 - 0 – No communication during ATI
 - 1 – Communications continue regardless of ATI state
- Bit 2: ATI band selection
 - 0 – Re-ATI when outside 1/8 of ATI target
 - 1 – Re-ATI when outside 1/16 of ATI target
- Bit 1: Redo ATI on all channels (Set only, will clear when done)
 - 1 – Start the ATI process
- Bit 0: Reseed All Long term filters (Set only, will clear when done)
 - 1 – Start the Reseed process



6.7.2 Active Channels Mask

Active Channels Mask (0xD1)								
Bit Number	7	6	5	4	3	2	1	0
Data Access	Read/Write							
Name			CH5	CH4	CH3	CH2	CH1	CH0
Default	0x3F							

Bit definitions:

- Bit 5: CH5 (**note: Ch2, Ch3, Ch4 and Ch5 must all be enabled for Hall effect rotation UI to be functional**)
 - 0: Channel is disabled
 - 1: Channel is enabled
- Bit 4: CH4 (**note: Ch2, Ch3, Ch4 and Ch5 must all be enabled for Hall effect rotation UI to be functional**)
 - 0: Channel is disabled
 - 1: Channel is enabled
- Bit 3: CH3 (**note: Ch2, Ch3, Ch4 and Ch5 must all be enabled for Hall effect rotation UI to be functional**)
 - 0: Channel is disabled
 - 1: Channel is enabled
- Bit 2: CH2 (**note: Ch2, Ch3, Ch4 and Ch5 must all be enabled for Hall effect rotation UI to be functional**)
 - 0: Channel is disabled
 - 1: Channel is enabled
- Bit 1: CH1
 - 0: Channel is disabled
 - 1: Channel is enabled
- Bit 0: CH0
 - 0: Channel is disabled
 - 1: Channel is enabled



6.7.3 Power Mode Settings

Power Mode Settings (0xD2)								
Bit Number	7	6	5	4	3	2	1	0
Data Access	Read/Write							
Name	-	Enable ULP Mode	Disable Auto Modes	Power mode		NP segment rate		
Default	0x03							

Bit definitions:

- Bit 6: Enable Ultra-Low Power Mode
 - 0: ULP is disabled during auto-mode switching
 - 1: ULP is enabled during auto-mode switching
- Bit 5: Disable auto mode switching
 - 0: Auto mode switching is enabled
 - 1: Auto mode switching is disabled
- Bit 4-3: Manually select Power Mode (**note: bit 5 must be set**)
 - 00: Normal Power mode. The device runs at the normal power rate, all enabled channels and UIs will execute.
 - 01: Low Power mode. The device runs at the low power rate, all enabled channels and UIs will execute.
 - 10: Ultra-Low Power mode. The device runs at the ultra-low power rate, Ch0 is run as wake-up channel. The other channels execute at the NP-segment rate.
 - 11: Halt Mode. No conversions are performed; the device must be removed from this mode using an I2C command. Disable Auto Mode switching by setting Bit 5.
- Bit 2-0: Normal Power Segment update rate
 - 000: ½ ULP rate
 - 001: ¼ ULP rate
 - 010: 1/8 ULP rate
 - 011: 1/16 ULP rate
 - 100: 1/32 ULP rate
 - 101: 1/64 ULP rate
 - 110: 1/128 ULP rate
 - 111: 1/256 ULP rate

6.7.4 Normal/Low/Ultra-Low power mode report rate

Normal/Low/Ultra-Low power mode report rate (0xD3 - 0xD5)								
Bit Number	7	6	5	4	3	2	1	0
Data Access	Read/Write							
Name	Normal/Low power/Ultra-low power mode report rate							

Register addresses:

- 0xD3: Normal mode report rate in ms (Default: 10 ms) (**note: LPOSC timer has +- 4 ms accuracy**)
- 0xD4: Low power mode report rate in ms (Default: 48 ms) (**note: LPOSC timer has +- 4 ms accuracy**)
- 0xD5: Ultra-low power mode report rate in 16 ms ticks (Default: 128 ms)



6.7.5 Auto Mode Time

Auto Mode Time (0xD6)								
Bit Number	7	6	5	4	3	2	1	0
Data Access	Read/Write							
Name	Mode time							
Default	0x14 = 10 sec							

Bit definitions:

- Bit 7-0: Auto modes switching time in 500 ms ticks

6.7.6 RDY timeout period

RDY timeout period (0xD8)								
Bit Number	7	6	5	4	3	2	1	0
Data Access	Read/Write							
Name	RDY timeout period value							
Default	0x20 = 10.24 ms							

Bit definitions:

- Bit 7-0: RDY timeout period = RDY timeout period value * 0.32 ms
 - 0 – 81.6 ms: RDY timeout period

6.7.7 I²C Settings

I ² C Settings (0xD9)								
Bit Number	7	6	5	4	3	2	1	0
Data Access	Read/Write	Read/Write	Read/Write	-				
Name	Stop Disable	R/O Check Disable	NP Stream Enable	Reserved				
Default	0	0	0	0	0	0	0	1

Bit definitions:

- Bit 7: Stop disable
 - 0: Stop enabled: Stop bit will exit the communication window.
 - 1: Stop disabled: Stop bit will not exit the communication window. No start within the RDY timeout period (0xD8) will exit the communication window without executing commands.
- Bit 6: Disable Read Only Check
 - 0: Normal R/O check is performed.
 - 1: R/O check is disabled.
- Bit 5: Always stream in Normal Power Mode
 - 0: Streaming override disabled
 - 1: Always stream in NP
- Bit 4 – 1: Reserved
 - Do not configure, leave cleared.
- Bit 0: Reserved
 - Must always be set (bit 0 = 1).



7. Electrical characteristics

7.1 Absolute Maximum Specifications

The following absolute maximum parameters are specified for the device:

Exceeding these maximum specifications may cause damage to the device.

Table 7-1 Absolute maximum specification

Parameter	IQS625-3yy
Operating temperature	-20°C to 85°C
Supply voltage range (VDDHI – GND)	2V - 3.6V
Maximum pin voltage	VDDHI + 0.5V (may not exceed VDDHI max)
Maximum continuous current (for specific Pins)	10mA
Minimum pin voltage	GND - 0.5V
Minimum power-on slope	100V/s
ESD protection	±4kV (Human body model)

7.2 Voltage regulation specifications

Table 7-2 Internal regulator operating conditions

Description	Chipset	Parameter	MIN	TYP	MAX	UNIT
Supply Voltage	IQS625-3yy	V _{DDHI}	2	-	3.6	V
Internal Voltage Regulator		V _{REG}	1.63	1.66	1.69	

7.3 Power On-reset/Brown out

Table 7-3: Power on-reset and brown out detection specifications

Description	Conditions	Parameter	MIN	MAX	UNIT
Power On Reset	V _{DDHI} Slope ≥ 100V/s @25°C	POR	1.15	1.6	V
Brown Out Detect	V _{DDHI} Slope ≥ 100V/s @25°C	BOD	1.2	1.6	



7.4 Digital input/output trigger levels

Table 7-4 Digital input/output trigger level specifications

Description	Conditions	Parameter	Temperature	MIN	TYP	MAX	UNIT
Input low level voltage	400kHz I ² C clock frequency	V _{in_LOW}	-20°C	32.12			% of VDDHI
			+25°C		34.84		
			+85°C			39.39	
Input high level voltage		V _{in_HIGH}	-20°C			71.51	
			+25°C		68.18		
			+85°C	66.06			
Output low level voltage		V _{out_LOW}	-20°C – +85°C		0		
Output high level voltage		V _{out_HIGH}	-20°C – +85°C		100		

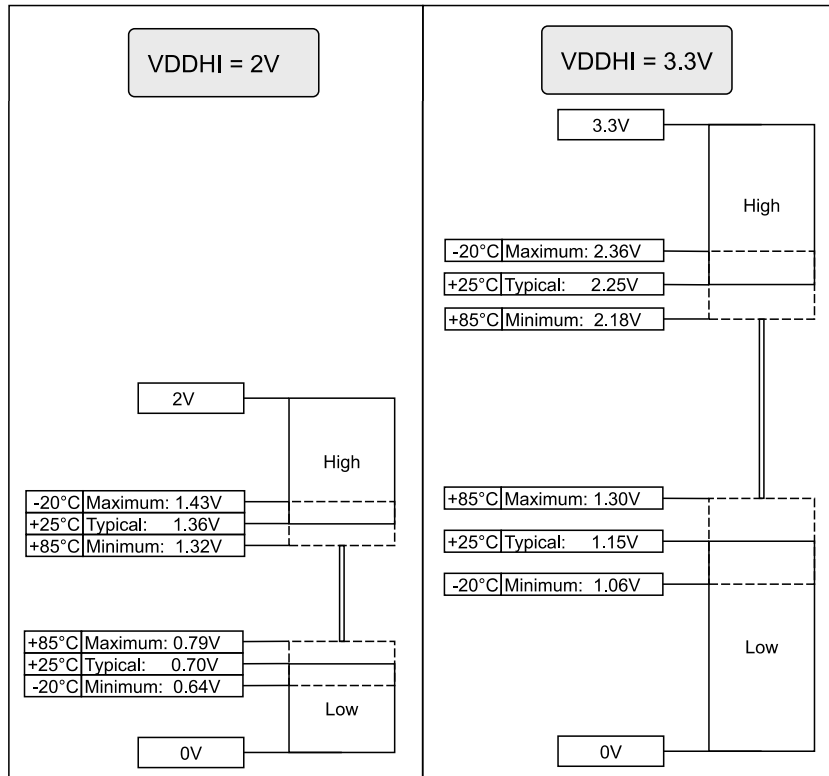



7.5 Current consumptions

Table 7-5 IC subsystem current consumption

Description	TYP	MAX	UNIT
Core active	339	377	μA
Core sleep	0.63	1	μA
Hall sensor active	1.5	2	mA

Table 7-6 IC subsystem typical timing

Description	Core active	Core sleep	Hall sensor active	Total	Unit
Normal	5	5	0.5	10	ms
Low	5	43	0.5	48	
Ultra-low	1.75	128	0	129.75	

7.5.1 Capacitive sensing alone

Table 7-7 Capacitive sensing current consumption

Power mode	Conditions	Report rate	TYPICAL	UNIT
Normal	VDD = 2V	10 ms	43.5	μA
	VDD = 3.3V	10 ms	44.4	
Low	VDD = 2V	48 ms	13.3	
	VDD = 3.3V	48 ms	13.8	
Ultra-low	VDD = 2V	128 ms	3.9	
	VDD = 3.3V	128 ms	4.5	

-These measurements were done on the default setup of the IC

7.5.2 Hall-effect sensing alone

Table 7-8 Hall-effect current consumption

Power mode	Conditions	Report rate	TYPICAL	UNIT
Normal	VDD = 2V	10 ms	215.2	μA
	VDD = 3.3V	10 ms	212.6	
Low	VDD = 2V	48 ms	58.3	
	VDD = 3.3V	48 ms	55.1	
	VDD = 2V	128 ms	TBA	
	VDD = 3.3V	128 ms	19.65	

-These measurements were done on the default setup of the IC

It is not advised to use the IQS625 in ULP without capacitive sensing. This is due to the Hall-effect sensor being disabled in ULP.

7.5.3 Halt mode

Table 7-9 Halt mode current consumption

Power mode	Conditions	TYPICAL	UNIT
Halt mode	VDD = 2V	1.6	μA
	VDD = 3.3V	1.9	μA



8. Package information

8.1 TSSOP-8 package specifications

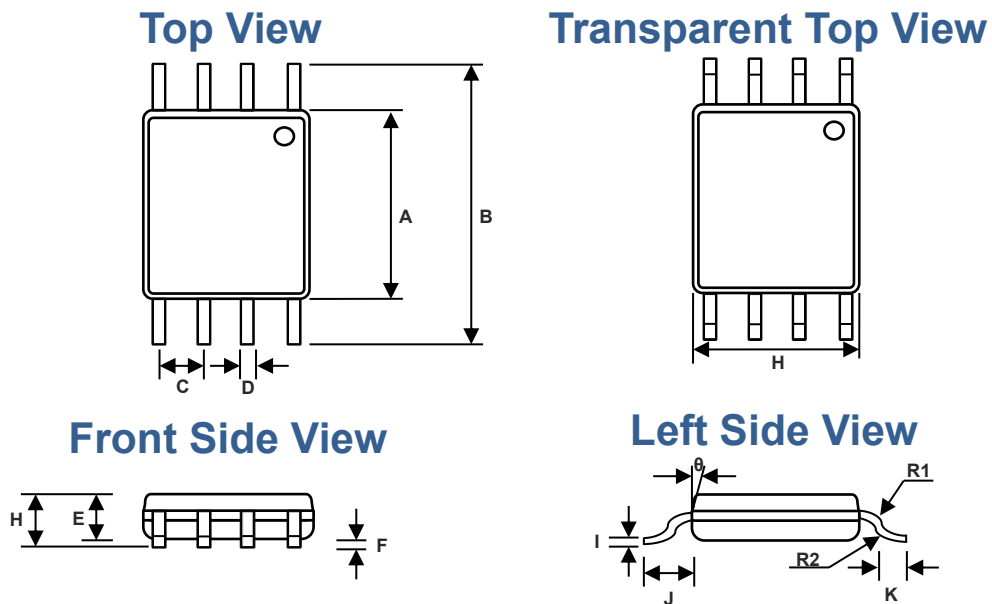

Table 8-1: TSSOP-8 Package Dimensions

Dimension	[mm]	Dimension	[mm]
A	4.4±0.1	H	3.0±0.1
B	6.40±0.15	I	0.15±0.5
C	0.65±0.05	J	1(MAX)
D	0.25±0.05	K	0.60±0.15
E	0.90±0.15	R1	0.15±0.05
F	0.10±0.05	R2	0.15±0.05
G	1.2±0.1	θ	12°±1°

8.2 TSSOP-8 Recommended PCB Footprint

Table 8-2 TSSOP-8 Landing dimensions

Dimension	[mm]
A	5.9
B	0.65
C	0.45
D	1.45
E	0.2

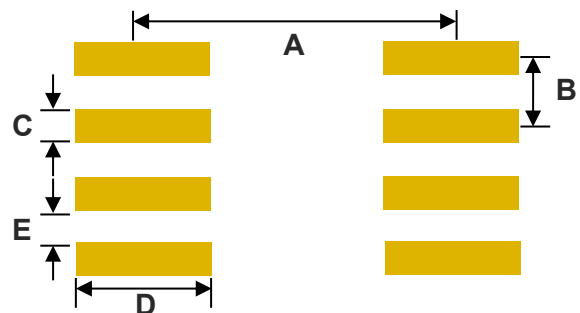
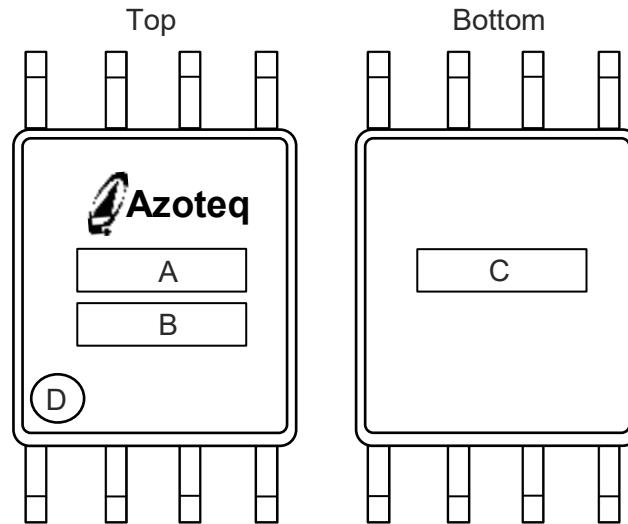

Figure 8-1 TSSOP-8 Landing dimension



8.3 Device marking and ordering information

8.3.1 Device marking:



IQS625 zty PWWYY
A B C

- A. Device name: IQS625
- B. z - IC revision number
- t - Temperature range
 - i: -20° to 85°C
- y – Config
 - 0: 44H sub-address
 - 1: 45H sub-address
- C. P -For internal use
- WWYY - Date code
- D. Pin 1: Dot

8.3.2 Ordering Information:

IQS625yppb

- y – Config
 - 0 or 1
- pp – Package type
 - TS (TSSOP-8)
- b – Bulk packaging
 - R (4k per reel, MOQ=1 Reel)

Example:

IQS625TSR

- 0 - config is default (44H sub-address)
- TS - TSSOP-8 package
- R - packaged in Reels of 4k (has to be ordered in multiples of 4k)



8.4 Tape and reel specification

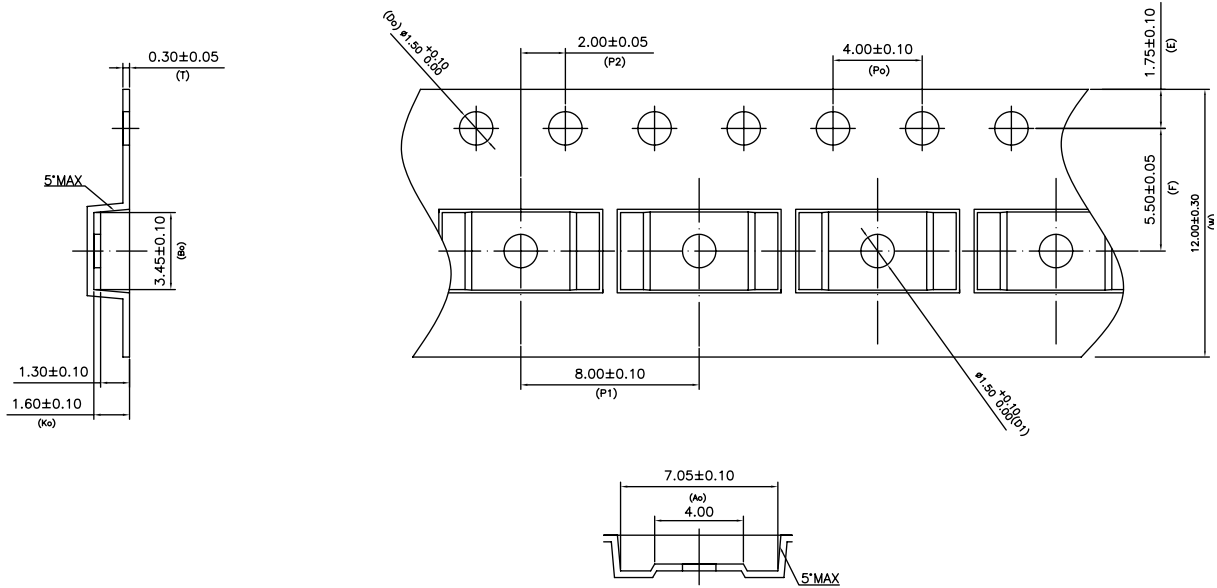

NOTES:

- 1.10 sprocket hole pitch cumulative tolerance±0.2
- 2.Camber not to exceed 1mm in 250mm.
- 3.Material: Black conductive Polystyrene.
- 4.Ao and Bo measured on a plane 0.3mm above the bottom of the pocket.
- 5.Ko measured from a plane on the inside bottom of the pocket to the top surface of the carrier.
- 6.Pocket position relative to sprocket hole measured as true position of pocket ,not pocket hole.
- 7.Pocket center and pocket hole center must be same position.

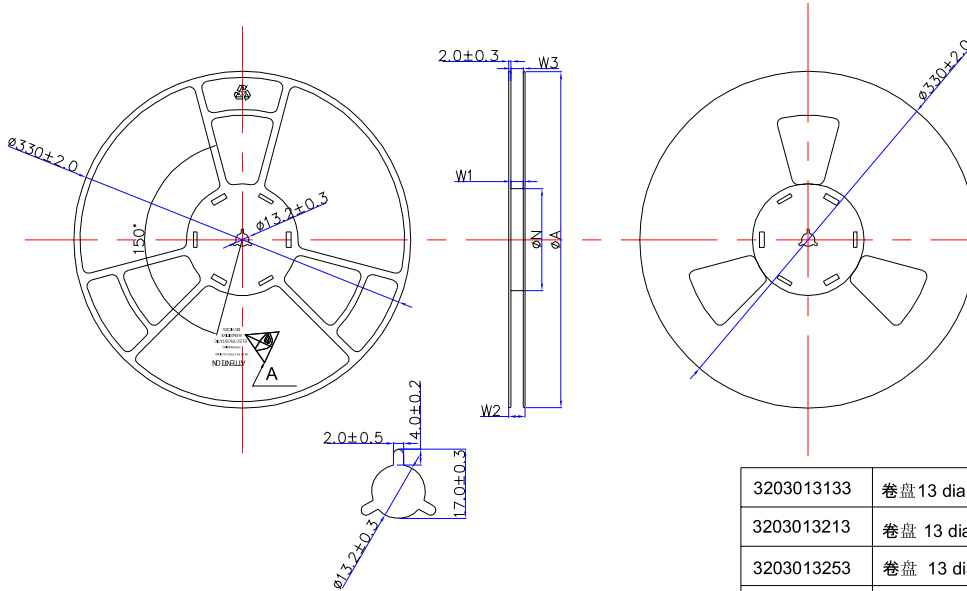

注意：

1. 材料：聚苯乙烯；
2. 平整度：最大允许3毫米；
3. 所有尺寸为毫米；
4. 表面电阻：10E5~10E11 CHS/SQ (除了16mm width的卷盘在温度25°C/-5° 以及湿度为50%RH~60%RH条件下，表面电阻满足10^5-10^9ohm范围内)
5. 所有未标注公差：± 0.5
6. 卷盘不可错位，可通过检验两个盘上A处的印字是否对应判断。

PRODUCT SPECIFICATIONS					
TYPE WIDTH	φA	φN	W1(±2σ)	W2 (Max)	W3 (Max)
12MM	330±2.0	100±1.0	12.4	18.4 Δ	11.9/15.4
16MM	330±2.0	100±1.0	16.4	22.4 Δ	15.9/19.4
24MM	330±2.0	100±1.0	24.4	30.4 Δ	23.9-27.4

3203013133	卷盘 13 dia Hub4 12mm width PS B(芯玮)
3203013213	卷盘 13 dia Hub4 16mm width PS B(芯玮)
3203013253	卷盘 13 dia Hub4 24mm width PS B(芯玮)
3203013134	卷盘 13 dia Hub4 12mm width PS blue
3203013255	卷盘 13寸 Hub4 24mm宽 PS 蓝色



8.5 MSL Level (Preliminary)

Moisture Sensitivity Level (MSL) relates to the packaging and handling precautions for some semiconductors. The MSL is an electronic standard for the time period in which a moisture sensitive device can be exposed to ambient room conditions (approximately 30°C/85%RH see J-STD033C for more info) before reflow occur.

Package	Level (duration)
TSSOP-8	MSL 1 (Unlimited at ≤30 °C/85% RH) Reflow profile peak temperature < 260 °C for < 25 seconds Number of Reflow ≤ 3



9. Datasheet revisions

9.1 Revision history

V1.0 – Initial Release



	USA	Asia	South Africa
Physical Address	11940 Jollyville Suite 120-S Austin TX 78750 USA	Room 501A, Block A, T-Share International Centre, Taoyuan Road, Nanshan District, Shenzhen, Guangdong, PRC	1 Bergsig Avenue Paarl 7646 South Africa
Postal Address	11940 Jollyville Suite 120-S Austin TX 78750 USA	Room 501A, Block A, T-Share International Centre, Taoyuan Road, Nanshan District, Shenzhen, Guangdong, PRC	PO Box 3534 Paarl 7620 South Africa
Tel	+1 512 538 1995	+86 755 8303 5294 ext 808	+27 21 863 0033
Email	info@azoteq.com	info@azoteq.com	info@azoteq.com

Visit www.azoteq.com
for a list of distributors and worldwide representation.

Patents as listed on www.azoteq.com/patents-trademarks/ may relate to the device or usage of the device.

Azoteq®, Crystal Driver , IQ Switch®, ProxSense®, ProxFusion®, LightSense™, SwipeSwitch™, and the  logo are trademarks of Azoteq.

The information in this Datasheet is believed to be accurate at the time of publication. Azoteq uses reasonable effort to maintain the information up-to-date and accurate, but does not warrant the accuracy, completeness or reliability of the information contained herein. All content and information are provided on an "as is" basis only, without any representations or warranties, express or implied, of any kind, including representations about the suitability of these products or information for any purpose. Azoteq disclaims all warranties and conditions with regard to these products and information, including but not limited to all implied warranties and conditions of merchantability, fitness for a particular purpose, title and non-infringement of any third party intellectual property rights. Azoteq assumes no liability for any damages or injury arising from any use of the information or the product or caused by, without limitation, failure of performance, error, omission, interruption, defect, delay in operation or transmission, even if Azoteq has been advised of the possibility of such damages. The applications mentioned herein are used solely for the purpose of illustration and Azoteq makes no warranty or representation that such applications will be suitable without further modification, nor recommends the use of its products for application that may present a risk to human life due to malfunction or otherwise. Azoteq products are not authorized for use as critical components in life support devices or systems. No licenses to patents are granted, implicitly, express or implied, by estoppel or otherwise, under any intellectual property rights. In the event that any of the abovementioned limitations or exclusions does not apply, it is agreed that Azoteq's total liability for all losses, damages and causes of action (in contract, tort (including without limitation, negligence) or otherwise) will not exceed the amount already paid by the customer for the products. Azoteq reserves the right to alter its products, to make corrections, deletions, modifications, enhancements, improvements and other changes to the content and information, its products, programs and services at any time or to move or discontinue any contents, products, programs or services without prior notification. For the most up-to-date information and binding Terms and Conditions please refer to www.azoteq.com.



11. Appendices

11.1 Appendix A: Magnet orientation

The IQS625 is able to calculate the angle of a magnet using two Hall sensors which are located in two corners of the die within the package. The two Hall sensors gather data of the magnet field strength in the z-axis. The difference between the two Hall sensors' data can be used to calculate a phase. This phase difference can then be transformed to degrees.

Key considerations for the IQS625:

- There must be a phase difference of 20° to 50° between the two Hall sensors.
It's impossible to calculate the angle if the phase difference is 0° or 180°.
- Reasonable N/S swing on each Hall sensor
A reasonable peak to peak signal is needed on the plates to ensure optimal on-chip angle calculation.

Table 11-1 Typical recommended magnet

Outer Radius	Inner Radius	Width	Grade	Distance between IC and Magnet axis
2.5 mm	1 mm	3 mm	N40	4 mm

Note: Increasing the width of the magnet can improve error caused by movement in the axis direction.

Ideal design considerations:

- Stable phase difference – This helps with the linearity of the maths.
- Big phase difference – The maths involved has better results with bigger phase difference.
- Distance between the sensors and the magnet should be the same for both – this insures that the magnet fields observed on both sensors are relatively the same.

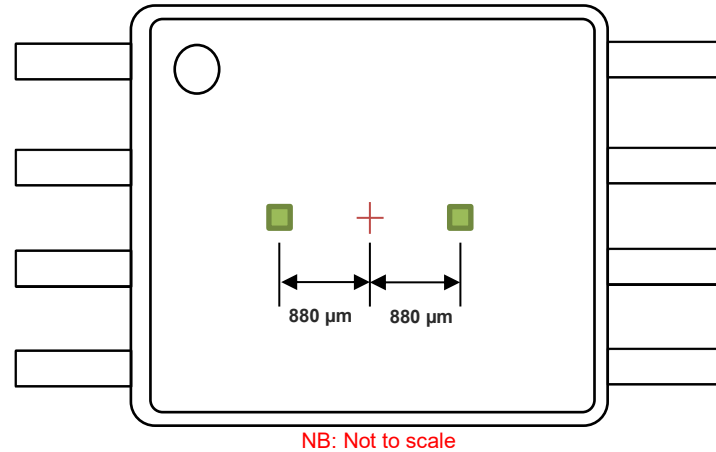

Figure 11-1 - Technical Drawing showing hall placement within the package. The Hall-Plates are shown as the two green pads and the center of the magnet is shown by the red cross.

11.1.1 Absolute or relative applications

There are two general applications for a Hall sensor, absolute and relative.

An **absolute application** requires the physical absolute angle of the magnet as an input. It is only possible to obtain the physical angle from a **dipole magnet**.

A **relative application** requires the difference between two positions of the magnet as an input. This makes it possible to use either a **dipole or multipole magnet**. The relative application can also be referred to as an incremental application.



11.1.2 Absolute off-axis magnet position relative to IC:

The IQS625 can be used as an off-axis hall rotation sensor. This means that the IC is placed on a PCB with the PCB parallel to the axis which it is measuring.

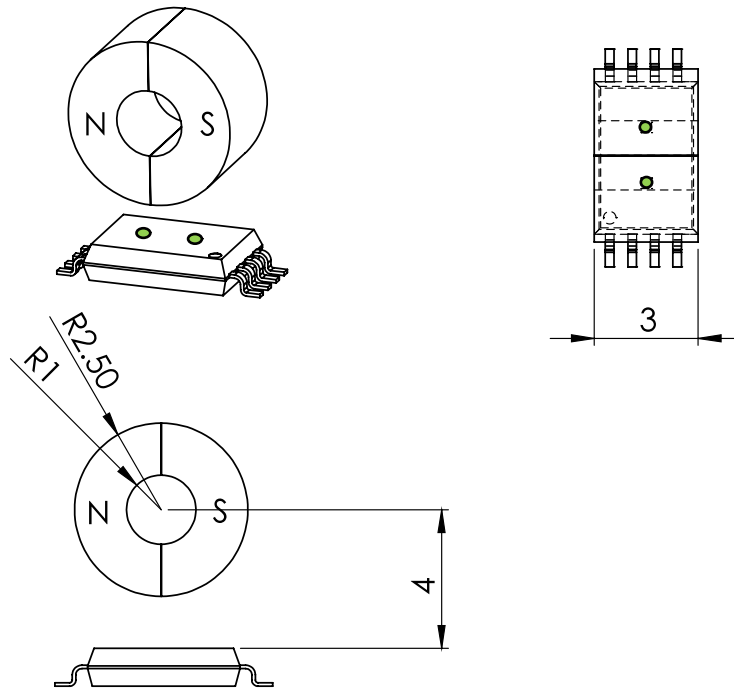

Figure 11-2 Magnet's position relative to IC with off-axis orientation

Table 11-2 Typical specifications of off-axis magnet position

	Variables	Typical
A	Outer radius	2.5 mm
B	Inner radius	1 mm
C	Thickness of magnet	3 mm
D	Distance between IC and Magnet Axis	4 mm
E	Angle of magnet relative to IC	0 degrees
F	Polarization	Diametrical
G	Magnetic grading	N40

11.1.3 Relative on-axis magnet position relative to IC:

The IQS625 as an on-axis hall rotation sensor. This means that the IC is placed on a PCB with the PCB perpendicular to the axis which it is measuring.

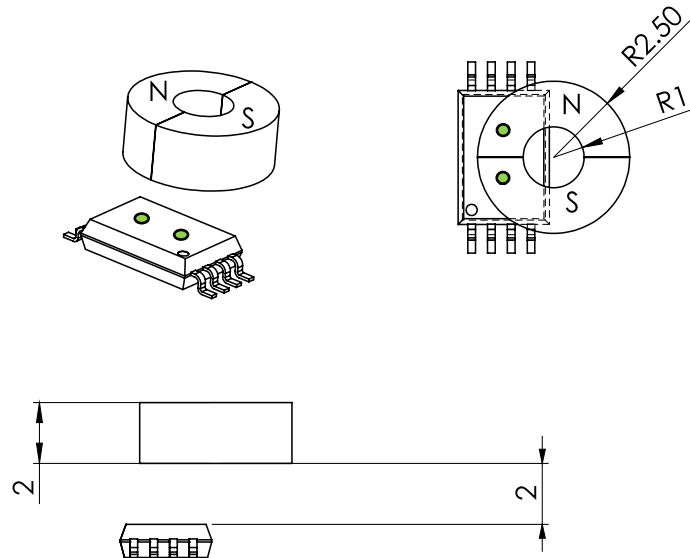

Figure 11-3 Magnet's position relative to IC with on-axis orientation

Table 11-3 Typical specifications of on-axis magnet position

	Variables	Typical
A	Outer radius	2.5 mm
B	Inner radius	1 mm
C	Thickness of magnet	2 mm
D	Distance between IC and Magnet	2 mm
E	Polarization	Diametrical
F	Magnetic grading	N40

Preferred magnet orientation comments

Both solutions promote the ideal conditions. However, the EV kit with the magnet parallel with the IC could be more ideal as shown previously. This design was chosen to display the ease of placement our product offers with the built-in corrections and linearization algorithms.

Small movements of the magnet have less impact on the phase difference.

The distance between the magnet and the two sensors are relatively equivalent.



11.2 Appendix B: Magnet calibration

The phase angle and the hall channels need to be calibrated on the IQS625. This can be done by a single rotation using the IQS625 GUI (Similar to the IQS624). The phase angle needs to be calibrated to calculate the angle between the magnet and IC while the hall channels need to be calibrated to determine the strength of the magnet.

11.2.1 Calibration During IC Production

The IQS625 is calibrated during IC production. The calibration ensures a more accurate and linear relation between the magnet and hall plates. Each IC is assigned to a calibration bin between 1 and 15. The bin index is stored in the lower nibble of Floating Gate 3. It is advised to use the bin index to ensure better accuracy over production. The calibration procedure was designed to ensure that the correct Hall ATI Settings are chosen for each setup.

The ATI target of each hall plate needs to be calibrated for the specific magnet strength of the application. Using the calibration data, the signal is calculated using the equation below:

$$i_a = I \times N_B (N_T^{-1} - n_z^{-1})$$

Where:

$i_a = \text{Signal}$

$I = \text{DC Current}$

$N_B = \text{Base Value Counts}$

$N_T = \text{ATI Target}$

$n_z = \text{Maximum Counts}$

It is not necessary to implement this equation on FW. The procedure below describes 5 easy steps to calibrate each application. The equation is used to generate a calibration table in the GUI which can be implemented in product FW. Therefore, the bin value of each IC is used to find the correct value in the Hall Wheel Calibration table generated by the GUI.

11.2.2 How to calibrate using the IQS625 GUI (To be released)

Each application/setup (not every single IC) should be calibrated with a single rotation to calculate the phase angle and ATI target values. The IQS625 GUI (to be released) should be used to calculate the correct calibration table for each application. A default “Max Counts” of 1500 is suggested. This procedure can still be used for phase angle calibration.



Step 1: Click on the Calibrate button in the GUI.

- a) This progress bar indicates that the calibration progress has started.
- b) The user must rotate the wheel on the IQS625 device 360 degrees.

(It is encouraged that the wheel must be rotated at a constant and low speed)



Step 2: Complete one full rotation until the “Calibration Completed” message is received.

(Repeat step 1 if the message: “Calibration Failed” is received.)

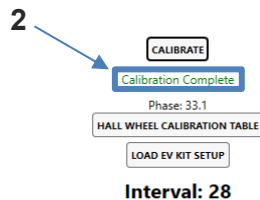



Step 3: Obtaining the Hall ATI Settings

- Click on Hall Wheel Calibration Table
- The Targets and Base values are automatically applied after Calibration Step
- If required Max Counts or Base Counts can be changed whereafter the Table Values should be calculated and applied.

The screenshot displays the Azoteq IQS625 Configuration Tool Manager. The main window is titled 'CONFIGURATION TOOL MANAGER' and shows various settings and a 'Hall Wheel Calibration Table' dialog box. The table contains target and base values for channels CH0 through CH5. A bar chart shows current counts for each channel. A 'Max Counts' input field is set to 1500. A 'CALIBRATION FAILED' message is visible in the top right corner.

Trim Value:	1	2	3	4	5
CH2/3 Target:	448	512	576	640	672
CH4/5 Target:	416	480	512	576	608
Trim Value:	6	7	8	9	10
CH2/3 Target:	448	512	576	640	672
CH4/5 Target:	448	512	576	608	672
Trim Value:	11	12	13	14	15
CH2/3 Target:	448	512	576	640	672
CH4/5 Target:	480	576	640	672	736

Counts: CH0: 881, CH1: 385, CH2: 485, CH3: 797, CH4: 688, CH5: 914
LTA: 0

Step 4: Inspect the channels

Check if the “Max Counts” selected for this application is reached (default = 1500). The base values or the Max Counts can be adjusted if this is not the case. Repeat Step 1-3 after the base values are adjusted.

Step 5: Obtaining the phase angle calibration constants

- Click on Sensor Hall Settings
- The phase angle calibration constants The Sin phase and Cos phase are the two constants which are written to the device.
- The phase (displayed in degrees) can also be used to obtain both of these constants.

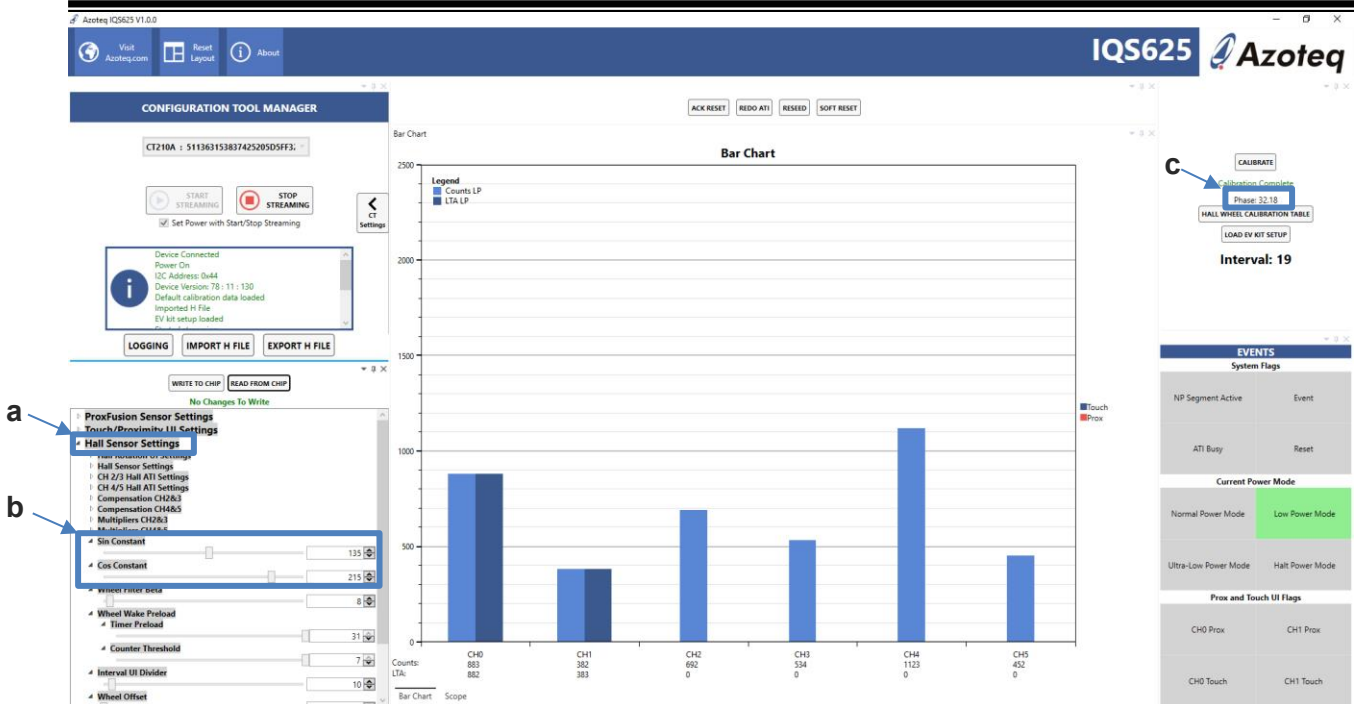

If the user is satisfied an h-file can be generated which includes the Hall ATI Settings for each IC. Click on Export H File

If this calibration is done on a product the constants obtained from the calibration can be used for projects with the same physical layout and magnet. This means that only one calibration is needed per product.

11.2.3 MCU Implementation

Before implementing the calibration data on an MCU the procedure described in Section 11.2.2 should be followed. Implement the steps below during initialisation of the MCU.

1. Power-up
2. Read the calibration index from Floating Gate 3.
 - a. I2C Start
 - b. Write 0x13 to register 0xF0
 - c. I2C Stop
 - d. I2C Start
 - e. Read from register 0xF1 and store calibration data
 - f. I2C Stop
3. Use the lower nibble of the floating gate to find the Hall ATI Settings in the Hall Wheel Calibration Table Values in the exported h-file from Section 11.2.2.
4. Write the Hall ATI Settings to registers 0x72 and 0x73 during setup of the IC.
5. Write the Cos and Sin constants to registers 0x79 and 0x7A.

For example:

- Lower nibble of Floating Gate 3 is 0x07.
- The exported Hall Wheel Calibration Table Values:

/ Hall Wheel Calibration Table Values */*



```
const static uint8_t Ch2_3_HALL_ATI_SETTINGS[] = {0xD0, 0xD3, 0xD5, 0xD6, 0xD8, 0xD0, 0xD3, 0xD5, 0xD6, 0xD8, 0xD0, 0xD3, 0xD5, 0xD6, 0xD8};
```

```
const static uint8_t Ch4_5_HALL_ATI_SETTINGS[] = {0xCF, 0xD1, 0xD3, 0xD4, 0xD6, 0xD0, 0xD2, 0xD4, 0xD6, 0xD7, 0xD2, 0xD4, 0xD6, 0xD8, 0xD9};
```

- The 7th value of each table is 0xD3 and 0xD2.
- During initialization write 0xD3 to register 0x72 and 0xD2 to register 0x73. (Hall ATI Settings)
- During initialization write 0x83 to register 0x79 and 0xDA to register 0x7A. (Phase Angle Constants)

11.2.4 How to calculate the phase angle using the raw data

There are two Hall Plates that make up the sensor, separated by a fixed distance in the IC package, as described previously. These plates, designated Plate 1 & Plate 2, each have two associated data channels that sense the North-South magnetic field coincident on the plates.

For Plate 1: CH2 is the non-inverted channel, and CH3 is the inverted channel.

For Plate 2: CH4 is the non-inverted channel, and CH5 is the inverted channel.

E.g. on Plate 1, if CH2 increases in value in the presence of an increasing North field, then CH3 decreases in value in the presence of an increasing North field.

The phase delta observed between the plates can be calculated from either the non-inverted, or the inverted channel pairs.

To calculate the phase delta:

Symbols

P_n	Non-inverted channel of Plate n: where $P_1 = CH_2$, and $P_2 = CH_4$
P'_n	Inverted channel of Plate n: $P'_1 = CH_3$, and $P'_2 = CH_5$
$P_n _{max}$	Max value of the channel
$P_n _{min}$	Min value of the channel
θ_Δ	Phase observed between the plates

Calculations

To calculate the phase, for at least one full rotation of the magnet, capturing all four channels:

First normalize the data for each channel, to obtain.

$$N(CH_n) = \frac{\frac{CH_n|_{max} - CH_n}{CH_n}}{CH_n|_{max} - CH_n|_{min}} \quad (1)$$

The data will now range between 0 – 1.

For the non-inverted pair: $\{P_2, P_1\} = \{CH_4, CH_2\}$ sample both channels where $N(CH_4) \approx 0.5$. With these values, the phase delta can be calculated:

$$\theta_\Delta = \sin^{-1}(|N(CH_4) - N(CH_2)| \cdot 2) \quad (2)$$

Likewise, the phase delta can be calculated from the inverted pair: $\{P'_2, P'_1\} = \{CH_5, CH_3\}$ sample both channels where $N(CH_5) \approx 0.5$.



$$\theta'_\Delta = \sin^{-1}(|N(CH_5) - N(CH_3)| \cdot 2) \quad (3)$$

And, while the phase angles are theoretically equal, due to misalignments, $\theta_\Delta \approx \theta'_\Delta$.

To increase accuracy of the observed phase, the two calculated phases can be averaged, leading the final Observed phase as:

$$\theta_\Delta = \frac{\sin^{-1}(|N(CH_4) - N(CH_2)| \cdot 2) + \sin^{-1}(|N(CH_5) - N(CH_3)| \cdot 2)}{2} \quad (4)$$

NB: Remember that $\{CH_4, CH_2\}$ are evaluated at $N(CH_4) \approx 0.5$. While separately, $\{CH_5, CH_3\}$ are evaluated at $N(CH_5) \approx 0.5$. Even when used together in Equation (4).

The IQS625 uses this phase delta as a constant to calculate the angle. The phase delta is saved on the IC after it has been converted to $(\sin(\theta_\Delta) \cdot 256)$ and $(\cos(\theta_\Delta) \cdot 256)$. This is done to lessen computations and memory usage on the chip.

This means that if the phase were to change, the constants would need to be recalculated. If the application of this IC ensures nothing or little movement, the master device would only need to write the values each time the IC resets and would not need to re-calculate it. Making it possible to calculate the phase delta once before production and using that value for the application.

An example of well aligned channels, the phase offset visible between the inverted and non-inverted channel pairs of the two plates:

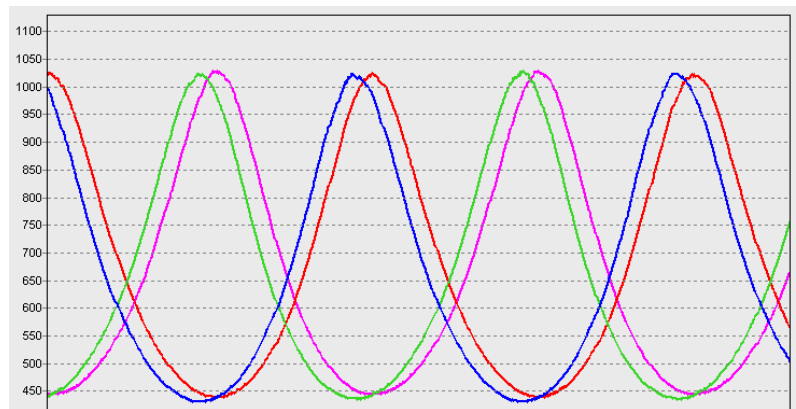

Experimentally, jog the XYZ alignment of the magnet relative to the IC and perform at least one full rotation of the magnet, assess the peaks of the channels; repeat this until all channels have approximately the same amplitude.

To change the sensitivity of the ProxEngine to Magnetic Field Strength, the ATI parameters on the IC can be adjusted as described in the following section.



11.3 Appendix C: Hall ATI

Azoteq’s ProxFusion® Hall technology has ATI Functionality; which ensures stable sensor sensitivity. The ATI functionality is similar to the ATI functionality found in ProxSense® technology. The difference is that the Hall ATI requires two channels for a single plate.

Using two channels ensures that the ATI can still be used in the presence of the magnet. The two channels are the inverse of each other, this means that the one channel will sense North and the other South. The two channels being inverted allows the capability of calculating a reference value which will always be the same regardless of the presence of a magnet.

11.3.1 Hall reference value:

The equation used to calculate the reference value, per plate:

$$Ref_n = \frac{1}{2 \cdot \left(\frac{1}{P_n} + \frac{1}{P'_n} \right)}$$

11.3.2 ATI parameters:

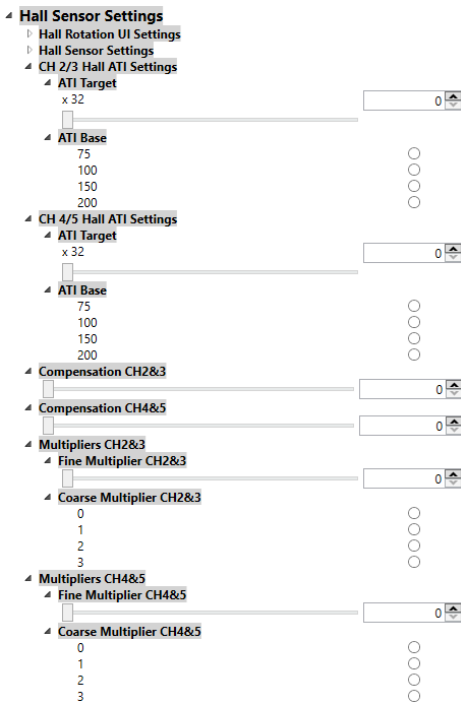

The ATI process adjusts three values (Coarse multiplier, Fine multiplier, Compensation) using two parameters per plate (ATI base and ATI target). The ATI process is used to ensure that the sensor’s sensitivity is not severely affected by external influences (Temperature, voltage supply change, etc.).

11.3.3 Coarse and Fine multipliers:

In the ATI process the compensation is set to 0 and the coarse and fine multipliers are adjusted such that the counts of the reference value (*Ref*) are roughly the same as the ATI Base value. This means that if the base value is increased, the coarse and fine multipliers should also increase and vice versa.

11.3.4 ATI-Compensation:

After the coarse and fine multipliers are adjusted, the compensation is adjusted till the reference value (*Ref*) reaches the ATI target. A higher target means more compensation and therefore more sensitivity on the sensor.

The ATI-Compensation adjusts chip sensitivity; and, must not be confused with the On-chip Compensation described below.

On-chip Compensation corrects minor displacements or magnetic non-linearities. This compensation ensures that both channels of each plate – which represent North and South individually – have the same swing. On-chip compensation is performed in the UI and is not observable on the raw channel data.

The ATI process ensures that long term temperature changes, or bulk magnetic interference (e.g. the accidental placement of another magnet too close to the setup), do not affect the sensor’s ability to detect the rotating magnet.



11.3.5 Recommended parameters:

There are recommended parameters to ensure optimal use. Optimally the settings would be set up to have a max swing of 1000 from peak to peak and a reference value below 1000 counts. This should not be confused with the Max Counts explained earlier.

The recommended parameters are:

- ATI Base: 100 or 150
- ATI Target: 500 – 1000

It is not assured that these settings will always set up the channels in the optimal region but it is recommended to rather adjust the magnet's position a little as this also influences the signal received. If the magnet is too close to the IC the swing will be too large, and thus it is recommended to increase the distance between the IC and the Magnet. Refer to Appendix B: Magnet calibration for more information when choosing the ATI target.

11.3.6 On-Chip Compensation

During a rotation of the magnet, the chip tracks important positions, 0/360° and 180°, as well as the MIN & MAX positions of the two plate equations R_b & R_t

Because the chip requires that the channels are aligned to the same amplitudes, the on-chip equations are as follows:

$$R_t = \frac{1}{CH_4} - \frac{1}{CH_2}$$

$$R_b = \frac{1}{CH_5} - \frac{1}{CH_3}$$

$$R = \frac{R_t}{R_b}$$

The Compensation Constant (κ) is tracked as:

$$\kappa = \frac{Max(R_b)}{Max(R_t)}$$

With R updated as

$$R = \kappa \cdot \frac{R_t}{R_b}$$

The update is only applied under certain conditions, both the *maxima* or *minima* of $\{R_b, R_t\}$ before crossing either 0° or 180° in a portion of the rotation. This means if the device wiggles between 150° & 200°, but does cross both maxima, the compensation is not updated.

At start-up, there is no compensation available and $\kappa = 1$

NOTE: After calibration, a rotation of the magnet is required to update the compensation value.

X-ON Electronics

Largest Supplier of Electrical and Electronic Components

Click to view similar products for [Board Mount Motion & Position Sensors](#) category:

Click to view products by [Azoteq](#) manufacturer:

Other Similar products are found below :

[6SS4](#) [XL-10043](#) [F02008062](#) [9970-090-9J-SA](#) [MT9105ET](#) [AS5270B-HMFM](#) [IPS2200BI1W](#) [EVW-ADF001B14](#) [AMN11111](#) [AMN31111](#)
[AMN34112](#) [AMN23111](#) [EKMC1693113](#) [EKMB1303111K](#) [EKMB1293112](#) [RBS130100](#) [RBS130200](#) [EKMB1305113K](#) [EKMB1105113](#)
[EKMB1205113](#) [OKY3062-2](#) [OKY3062-4](#) [OKY3062-5](#) [OKY3063](#) [OKY3221](#) [OKY3226](#) [OKY3230](#) [OKY3231](#) [OKY3231-1](#) [OKY3231-2](#)
[OKY3231-3](#) [OKY3231-4](#) [OKY3231-5](#) [OKY3231-6](#) [OKY3231-7](#) [OKY3231-8](#) [OKY3235](#) [OKY3238](#) [OKY3239](#) [OKY3248-1](#) [OKY3248-2](#)
[OKY3248-3](#) [OKY3252](#) [OKY3254](#) [OKY3254-1](#) [OKY3255](#) [3-AXIS DIGITAL ACCELEROMETER\(±1.5G\)](#) [3-AXIS DIGITAL ACCELEROMETER\(±16G\)](#) [9536](#) [AMA145915](#)