

SPECIFICATION

- Part No. : **TG.10.0113**

- Product Name : **Triton** - 2G/3G/4G Terminal Antenna for Cellular Gateways and Routers with Assisted GPS Hinged SMA(M)

- Features : LTE / GSM / CDMA /GPS/ DCS /PCS / WCDMA / UMTS / HSPA / GPRS / EDGE /IMT 698MHz to 960MHz, 1710MHz to 2690Mhz
 Dipole Terminal Antenna
 Hinged SMA(M) Connector
 Dimensions: Length 168*18*13mm,Φ13mm
 RoHS Compliant



1. Introduction

The TG.10 Triton dipole Antenna designed primarily for use with 3G and 4G Cellular Gateways and Routers, with assisted GPS. It does not require a ground-plane to connect to. It has a quality robust PC+ABS housing. The antenna has a SMA(M) connector. It can be used straight or hinged 90 degrees. The antenna has a wide-band high efficiency response on nearly all 2G/3G/4G frequency bands worldwide, and can also be used for other cellular and wireless applications such as GSM, and 2.4GHz WI-FI.

2. Specification

ELECTRICAL								
In free space								
Frequency (MHz)	703~803	824~894	880~960	1575.42	1710~1880	1850~1990	1920~2170	2490~2690
Efficiency (%)								
straight	41.82	33.71	26.83	26.17	41.01	35.76	39.76	46.48
bent	48.78	45.62	40.51	26.82	49.05	43.56	47.78	55.37
Average Gain(dBi)								
straight	-3.80	-4.74	-5.73	-5.82	-3.92	-4.48	-4.03	-3.44
bent	-3.12	-3.41	-3.93	-5.71	-3.14	-3.62	-3.22	-2.63
Peak Gain(dBi)								
straight	0.34	0.03	-0.48	-1.85	0.67	-0.07	0.23	2.04
bent	-0.21	0.35	0.22	-2.00	1.00	0.65	1.30	3.45
With 15cm X 9cm ground								
Frequency (MHz)	703~803	824~894	880~960	1575.42	1710~1880	1850~1990	1920~2170	2490~2690
Efficiency (%)								
straight	71.68	49.29	43.13	20.87	57.84	67.45	74.31	66.25
bent	74.12	61.90	51.94	23.16	53.64	67.19	73.14	68.20
Average Gain(dBi)								
straight	-1.45	-3.08	-3.66	-6.80	-2.38	-1.74	-1.30	-1.84
bent	-1.30	-2.09	-2.86	-6.35	-2.71	-1.76	-1.36	-1.70
Peak Gain(dBi)								
straight	2.85	1.20	0.19	-2.47	2.34	3.57	4.22	3.95
bent	1.43	0.79	-0.13	-1.44	2.08	2.69	2.96	4.44
On 30cmX30cm ground plane edge								
Frequency (MHz)	703~803	824~894	880~960	1575.42	1710~1880	1850~1990	1920~2170	2490~2690
Efficiency (%)								
straight	57.56	41.53	42.09	18.06	75.91	71.83	68.52	57.08
bent	57.30	48.37	42.12	20.37	72.62	71.93	70.21	58.98
Average Gain(dBi)								
straight	-2.41	-3.82	-3.76	-7.43	-1.20	-1.44	-1.65	-2.50
bent	-2.42	-3.19	-3.76	-6.90	-1.39	-1.43	-1.54	-2.36
Peak Gain(dBi)								
straight	2.96	0.68	-0.01	-3.02	3.37	2.83	2.82	3.17
bent	0.61	-0.78	-0.87	-2.61	3.49	4.63	4.76	3.12

On 30cmX30cm ground plane center								
Frequency (MHz)	703~803	824~894	880~960	1575.42	1710~1880	1850~1990	1920~2170	2490~2690
Efficiency (%)								
straight	42.15	28.00	20.35	24.88	39.11	49.92	55.35	47.74
bent	27.52	21.92	15.49	24.23	61.22	64.56	62.92	56.43
Average Gain(dBi)								
straight	-3.76	-5.65	-6.92	-6.04	-4.09	-3.04	-2.58	-3.33
bent	-5.63	-6.67	-8.12	-6.15	-2.14	-1.90	-2.02	-2.52
Peak Gain(dBi)								
straight	-0.06	-0.66	-1.81	-2.50	0.98	2.01	2.33	2.07
bent	-0.31	-2.93	-4.79	1.22	4.11	5.42	4.94	4.70
Impedance	50Ω							
Polarization	Linear							
Radiation Pattern	Omni							
Input power	5 W							
MECHANICAL								
Dimensions	Length 168*18*13mm,Φ13mm							
Casing	PC+ABS							
Connector	Hinged SMA Male							
Weight	24g							
Recommended Torque for Mounting	0.9 N·m							
Max Torque for Mounting	1.176 N·m							
ENVIRONMENTAL								
Temperature Range	-40°C to 85°C							
Humidity	Non-condensing 65°C 95% RH							

*All the bent testing are at 90 degrees bent.

3. Antenna Characteristics

3.1 Testing Setup

In free space



Antenna straight



Antenna bent

On 15X9cm ground plane

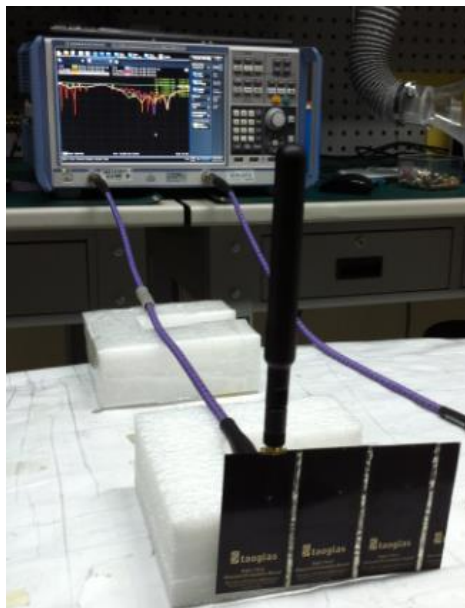

Antenna straight

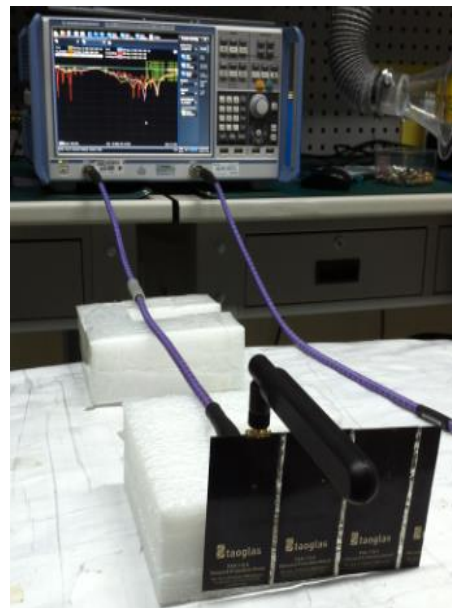

Antenna bent

On 30cm X 30cm ground plane edge



Antenna straight



Antenna bent

On 30cm X 30cm ground plane center



Antenna straight

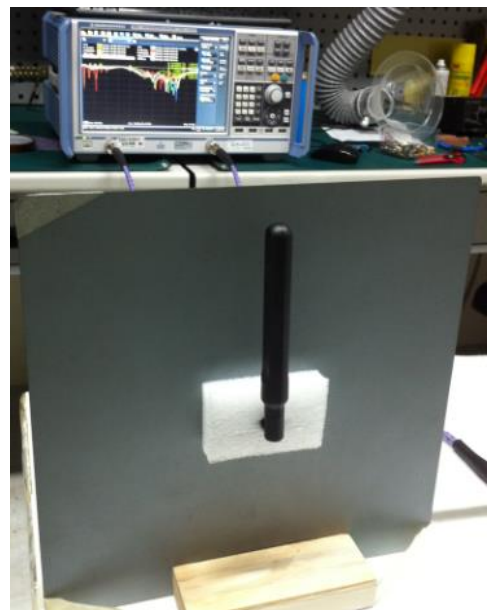

Antenna bent



3.2 Return Loss

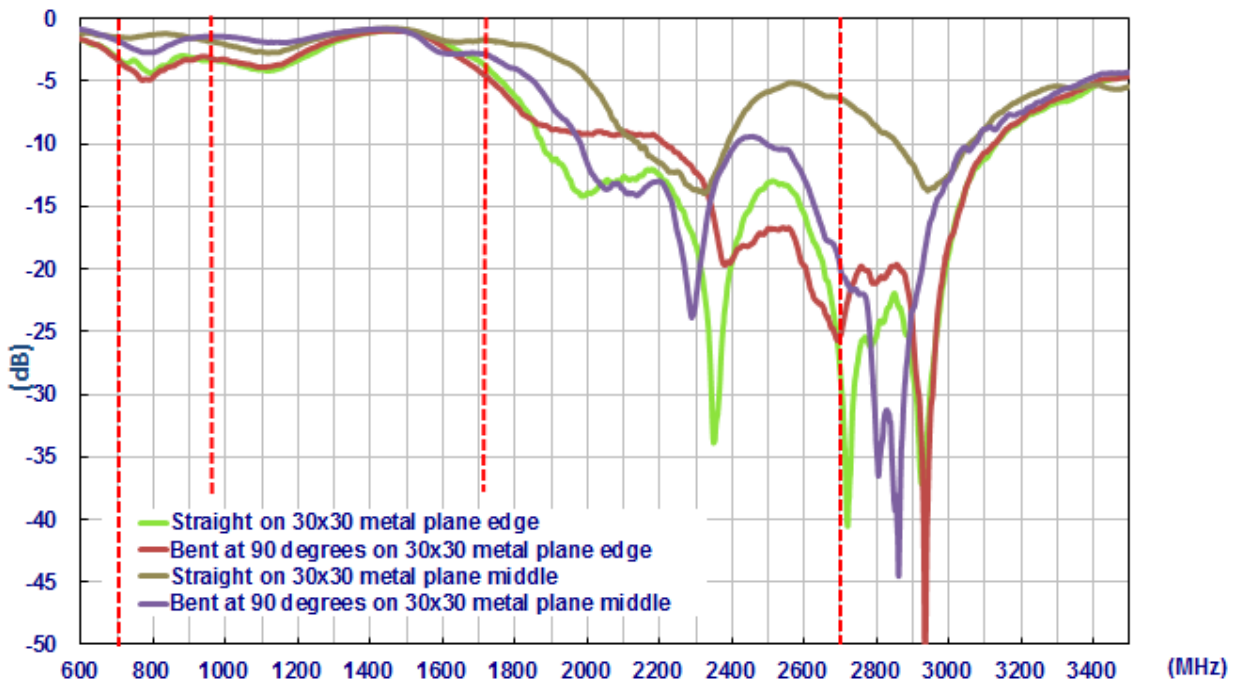
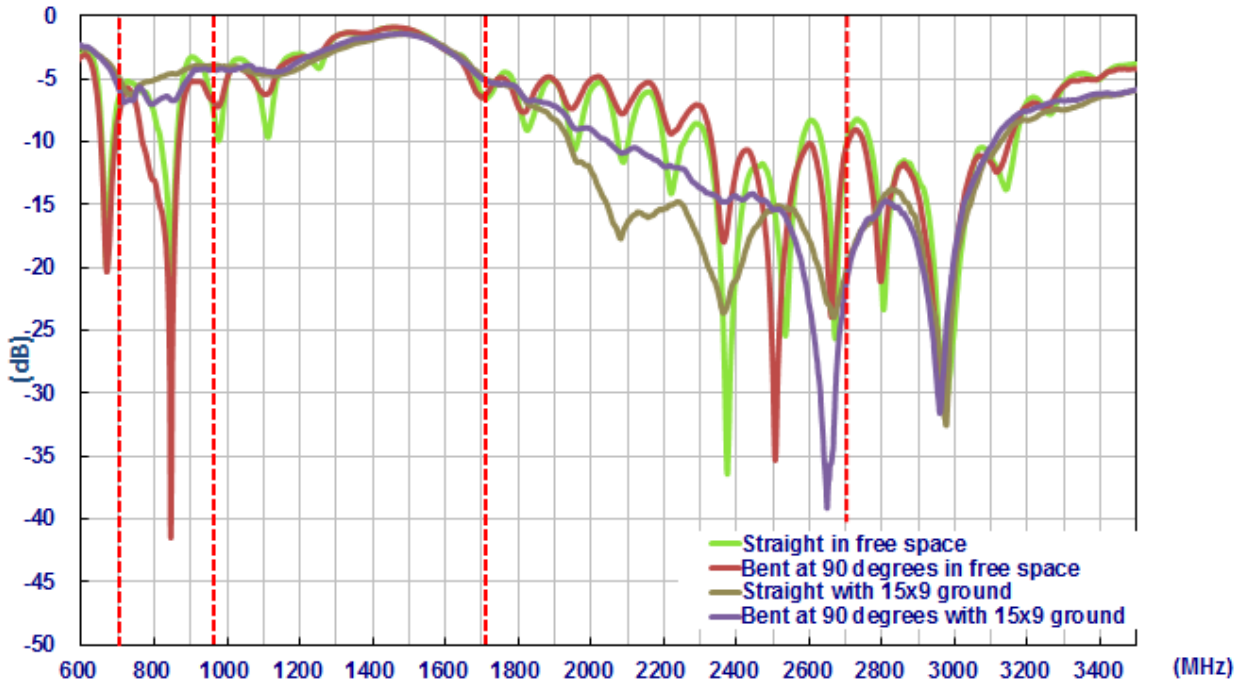

3.3 Peak Gain

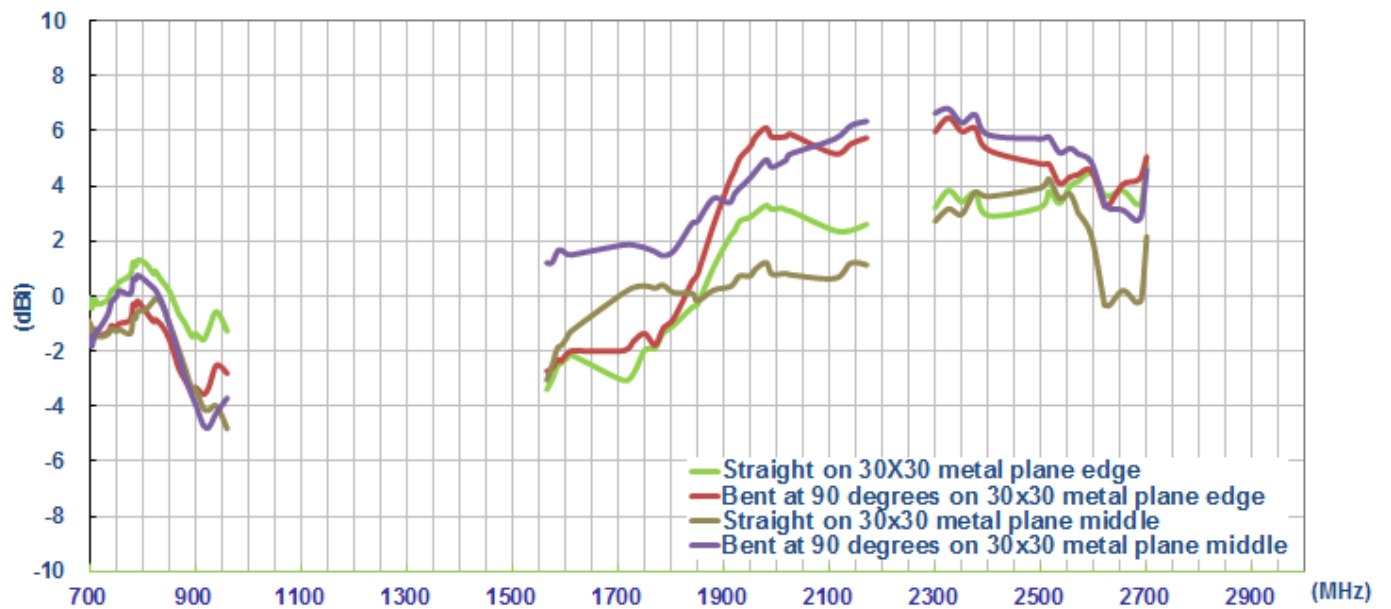
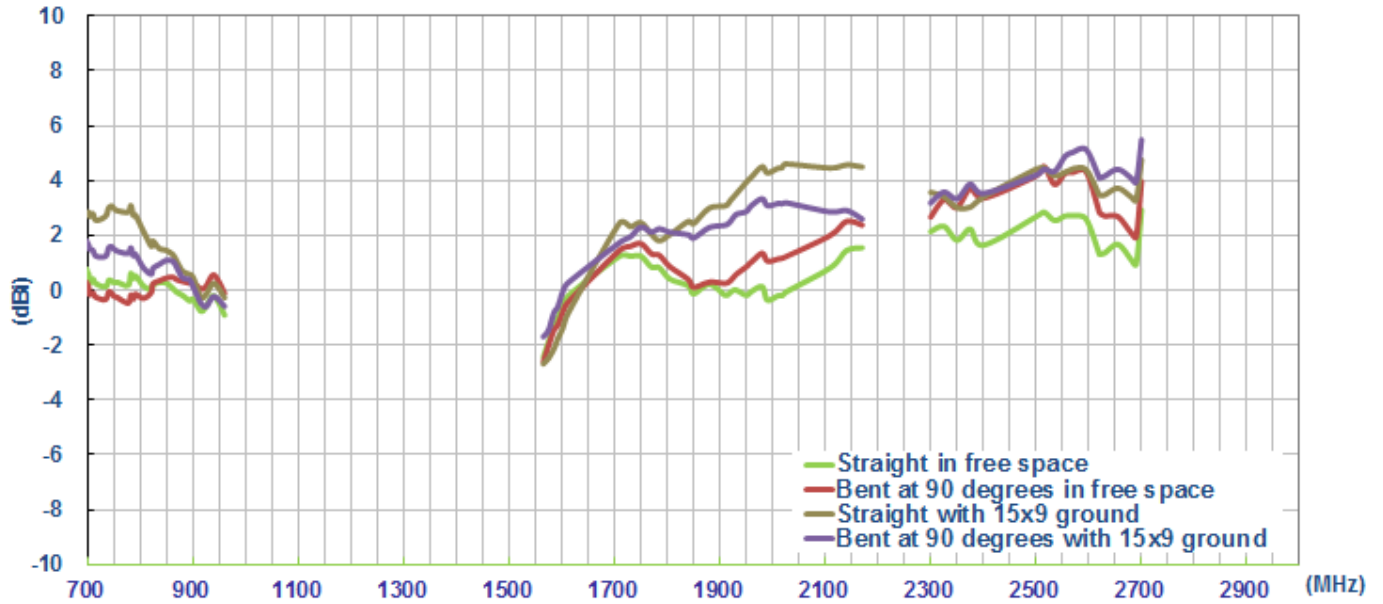

3.4 Efficiency

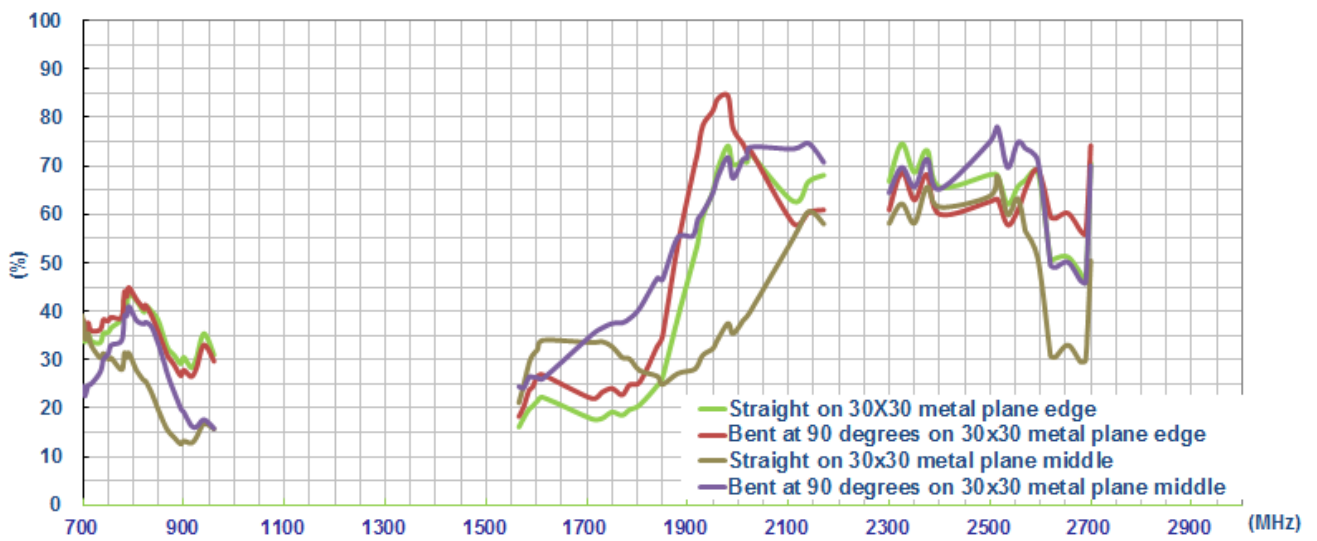
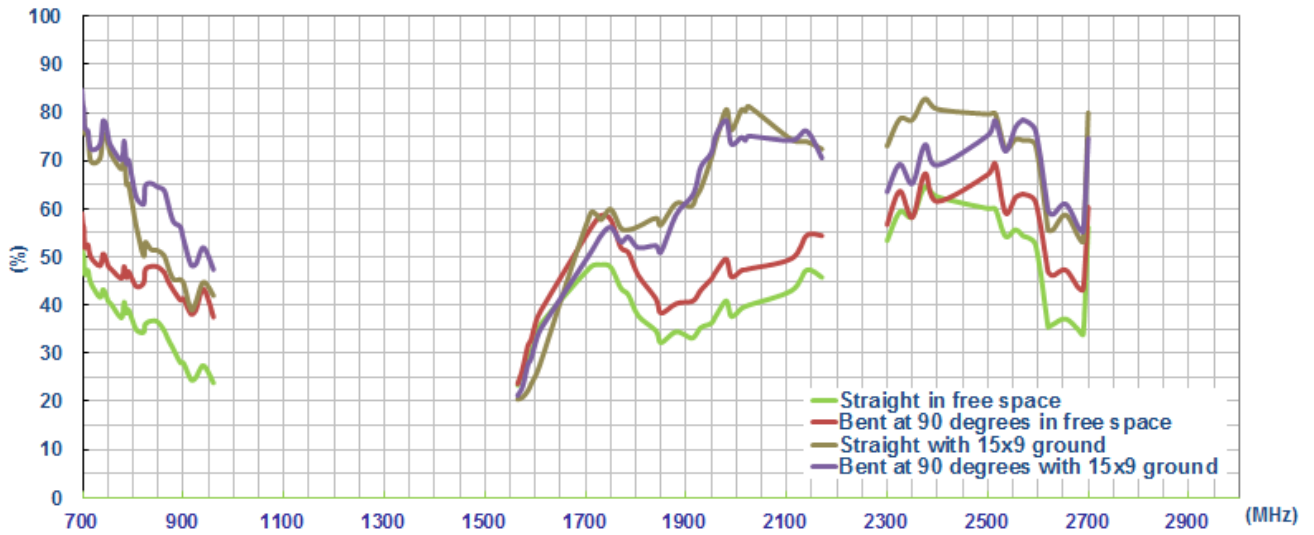

3.5 Average Gain

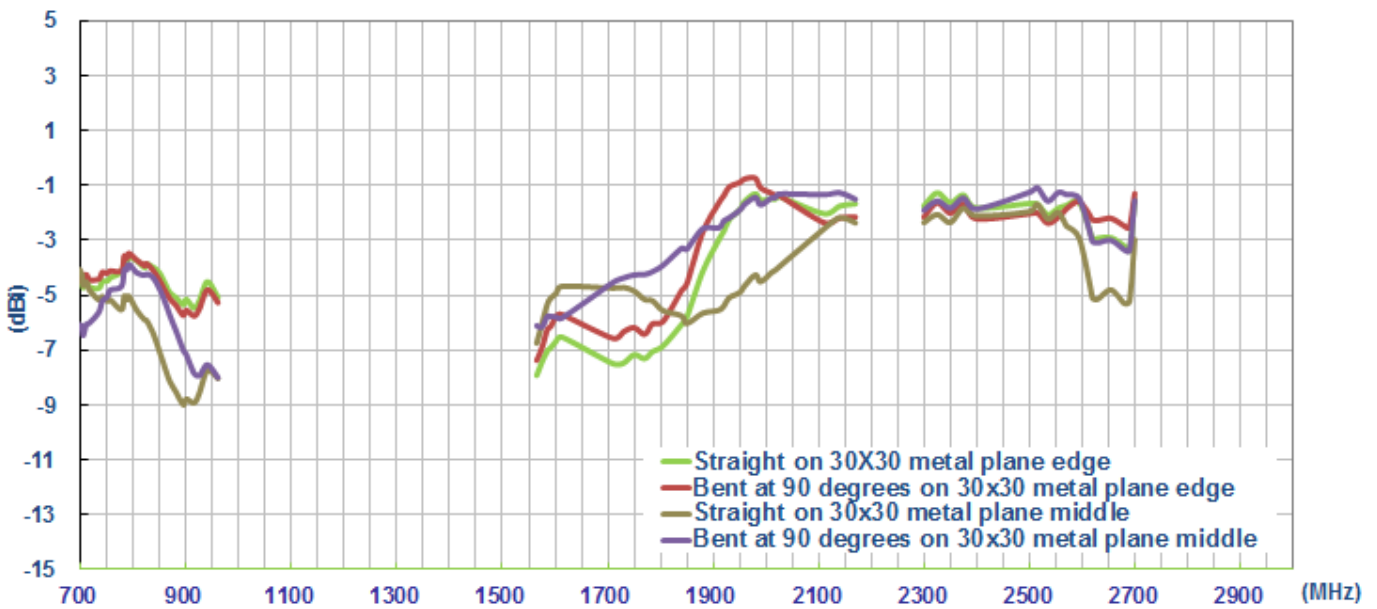
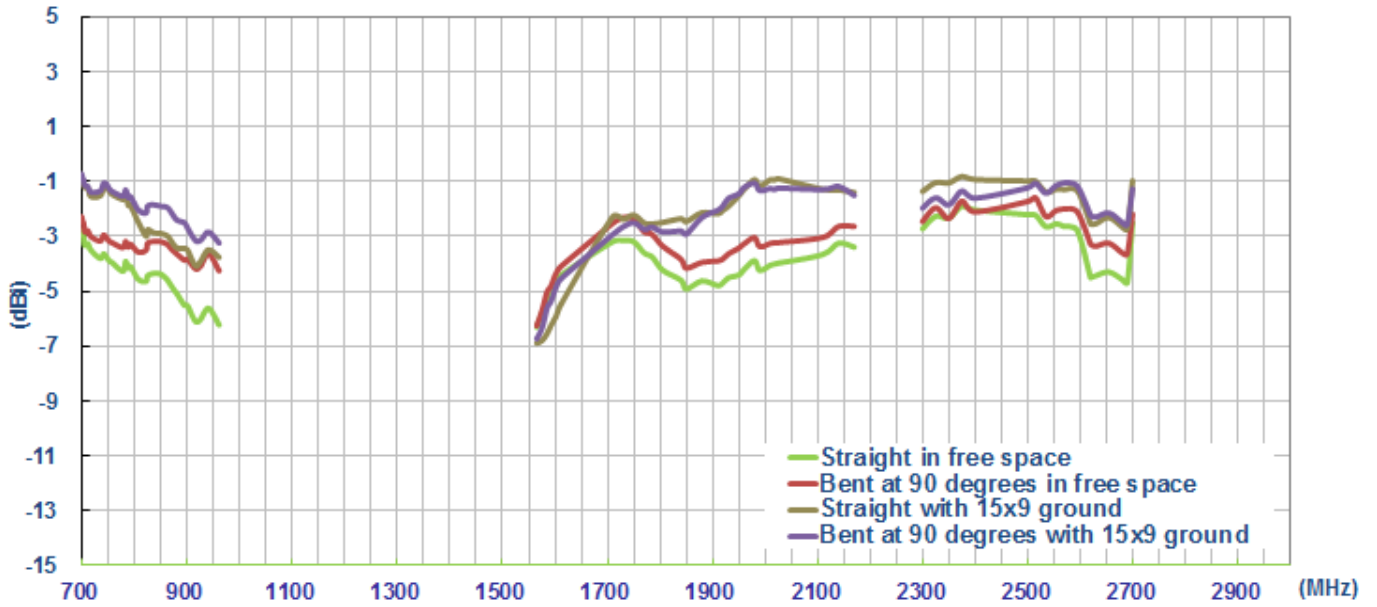

4. Antenna Radiation Patterns

4.1 Antenna Setup – Straight In Free Space

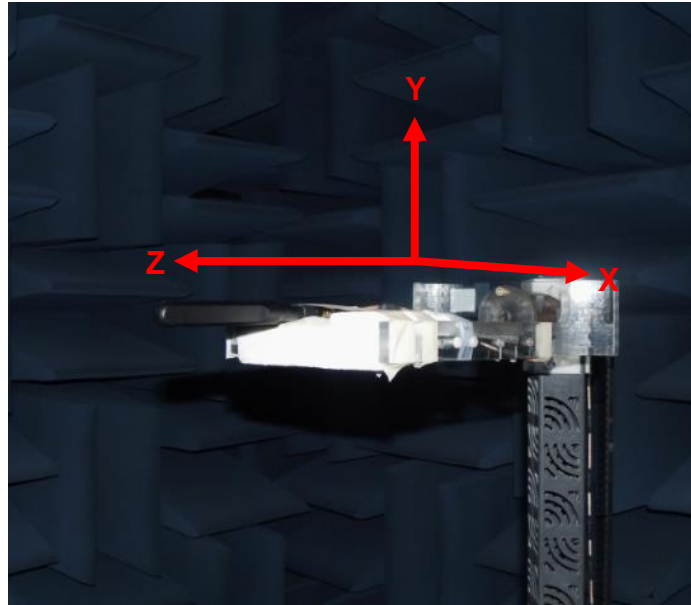

Antenna straight in free space

- Antenna Radiation Patterns

X-Y plane

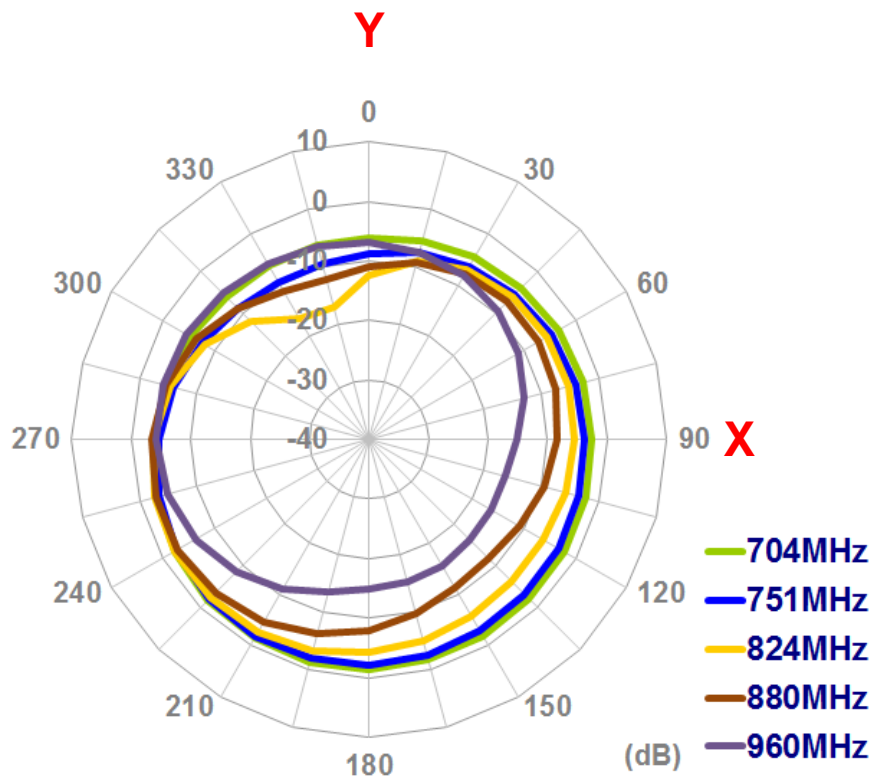

X-Z plane

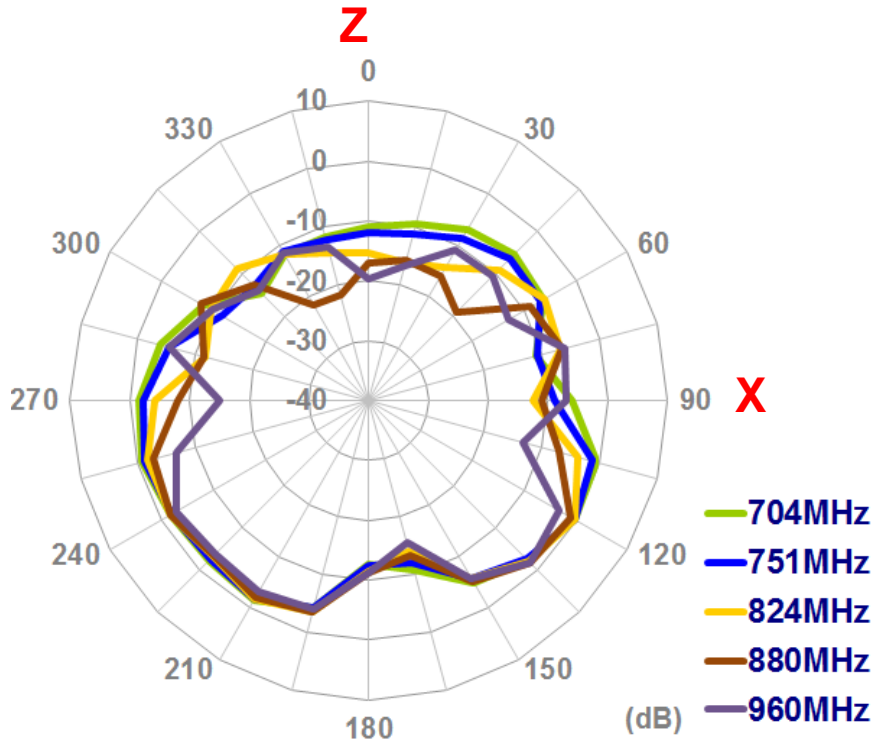

Y-Z plane

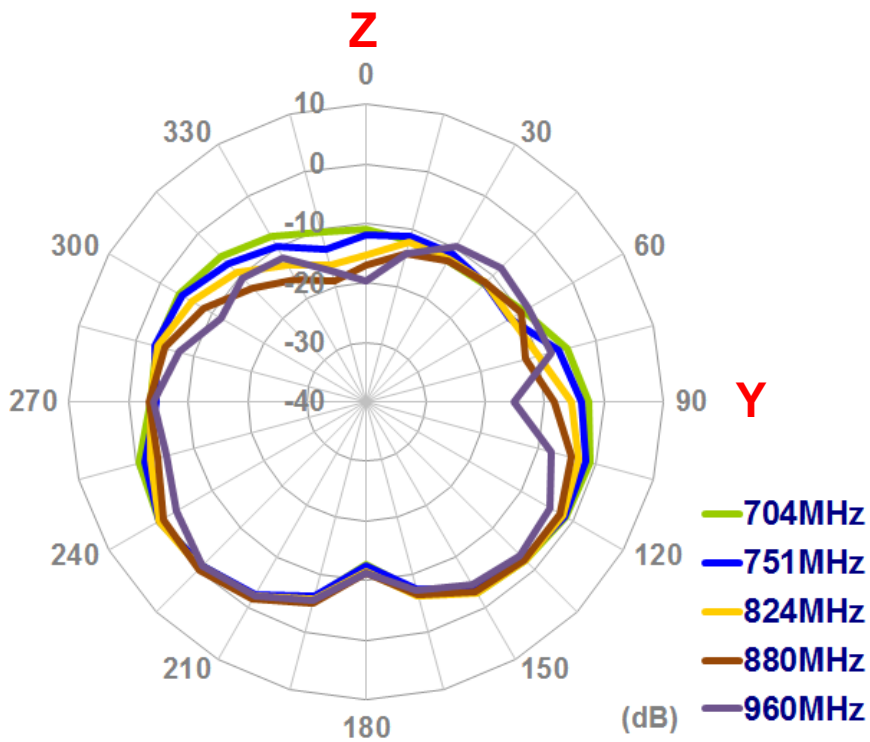

X-Y plane

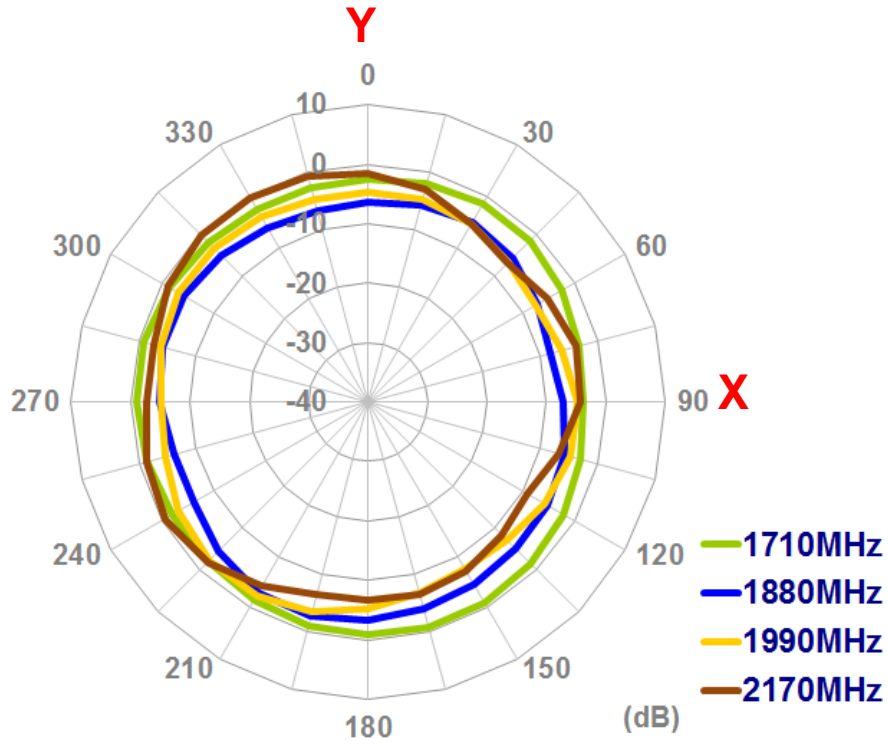

X-Z plane

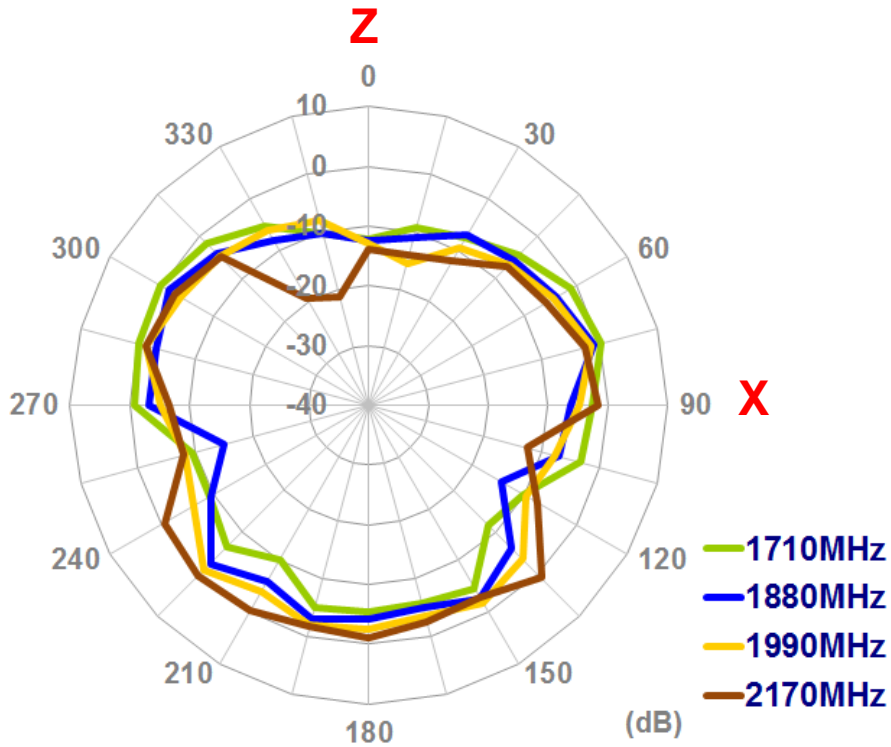

Y-Z plane

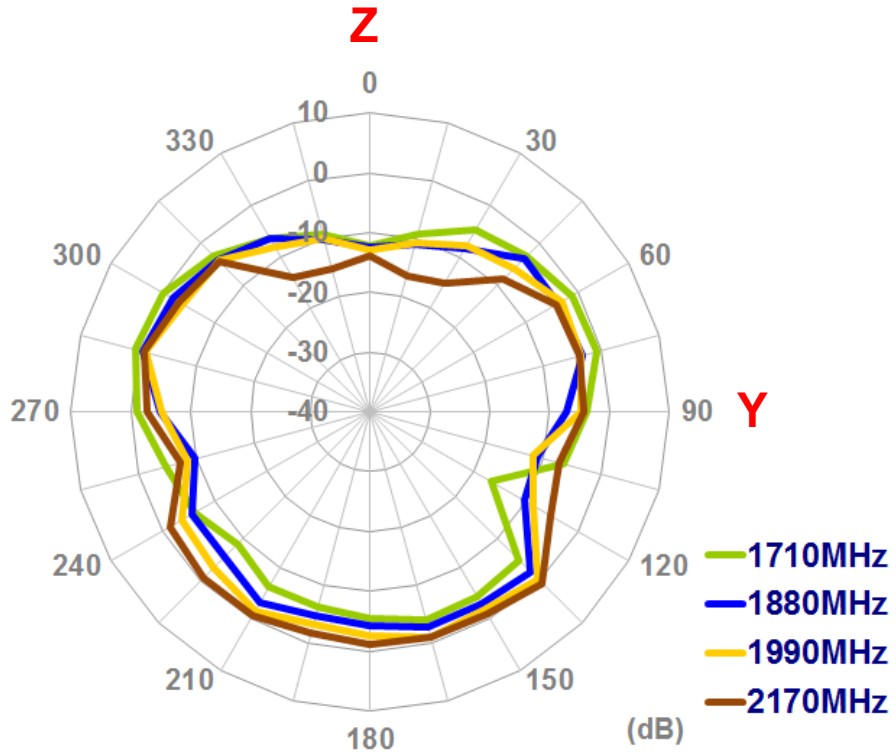

X-Y plane

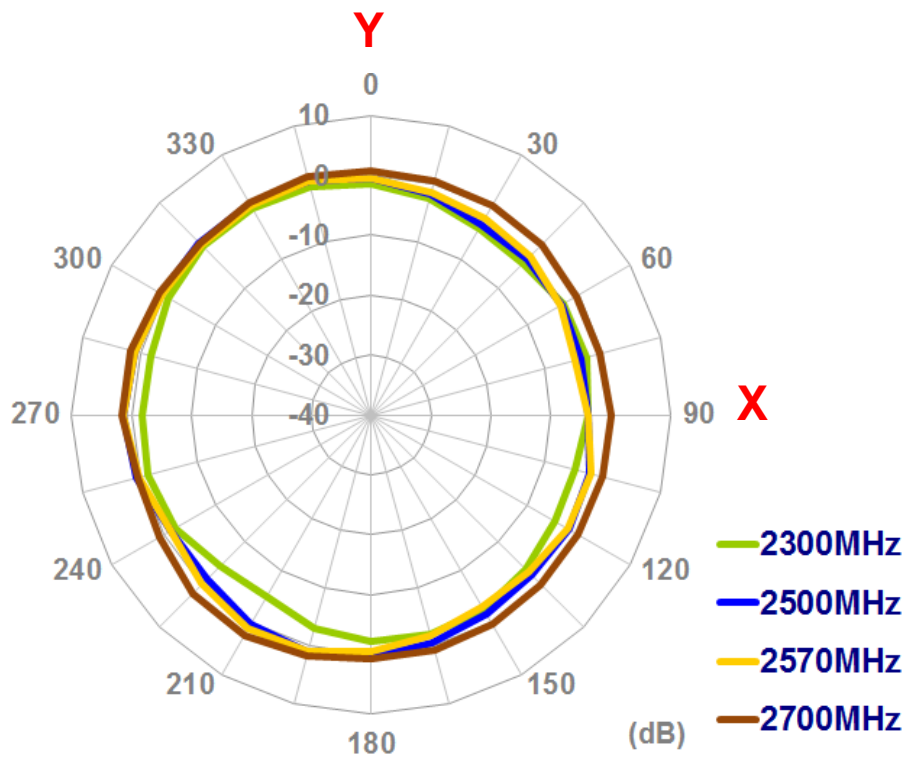

X-Z plane

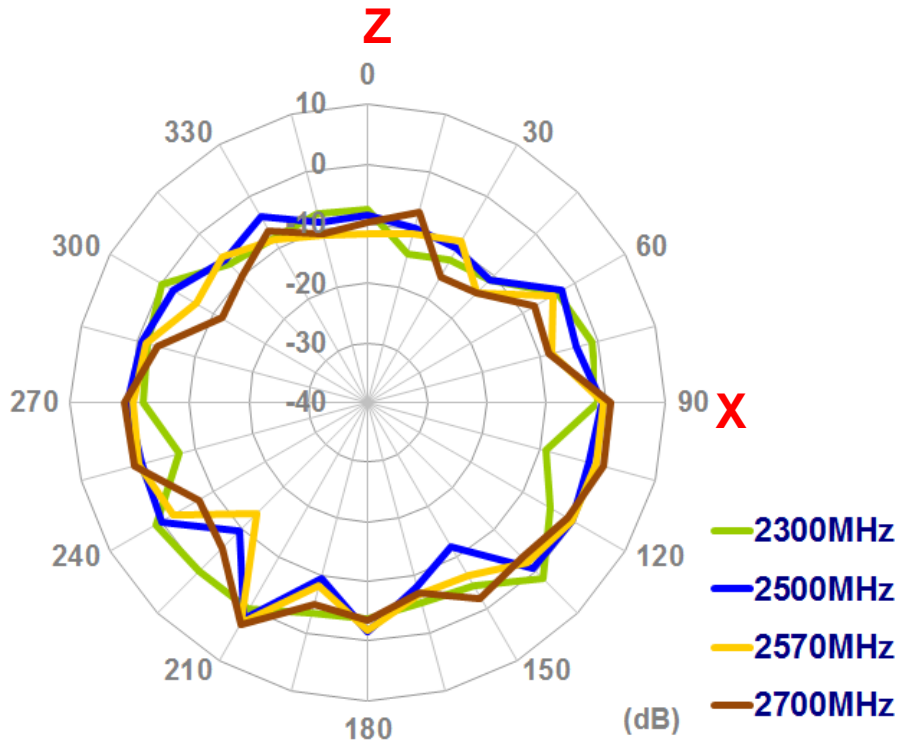

Y-Z plane

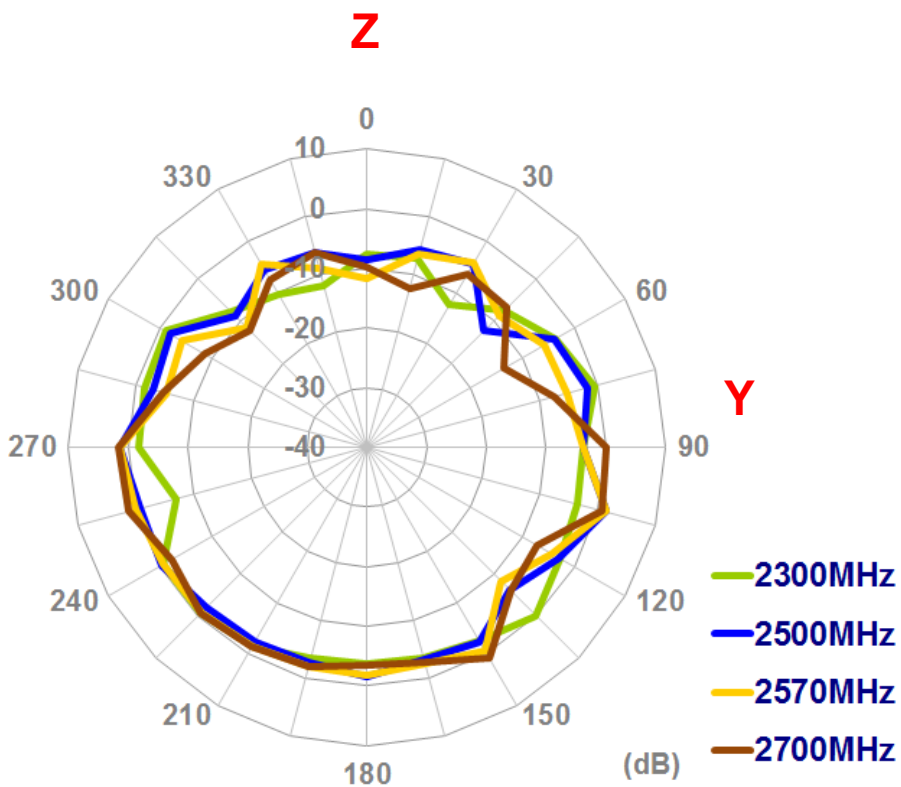

4.2 Antenna Setup – Bent At 90 Degrees In Free Space

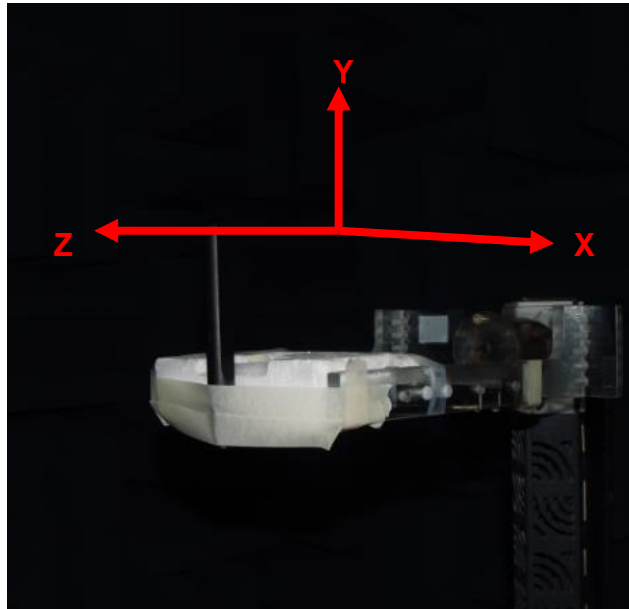

Antenna bent 90 degrees in free space

- **Antenna Radiation Patterns**

X-Y plane

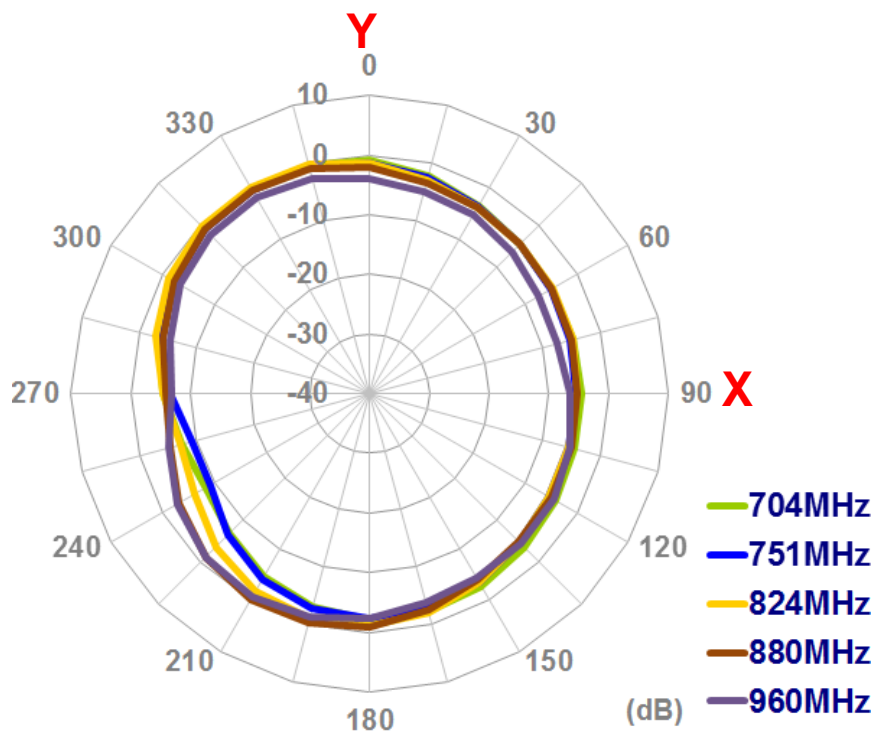

X-Z plane

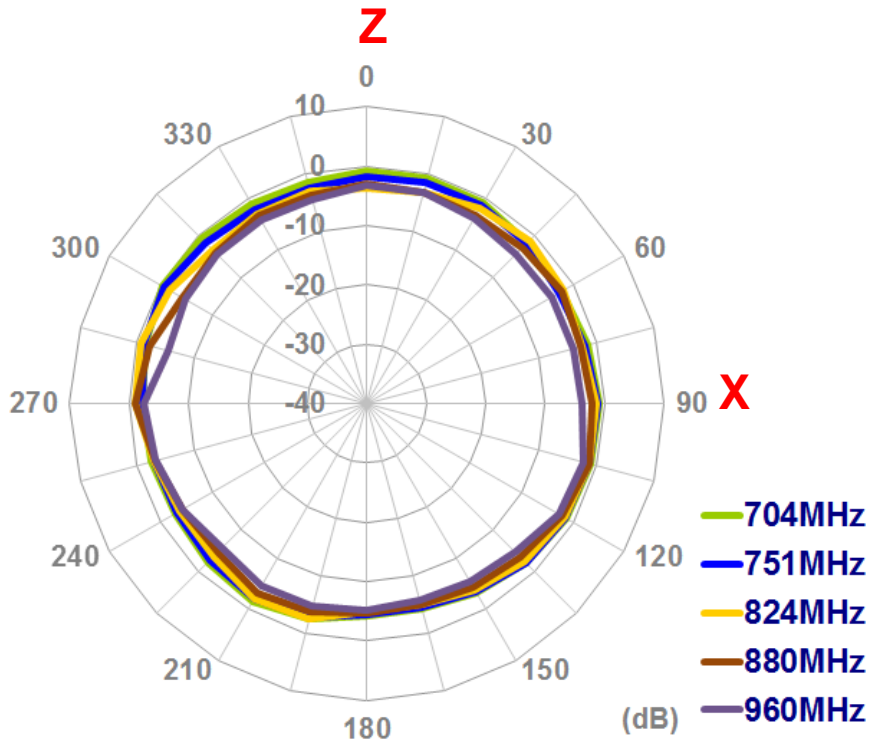

Y-Z plane

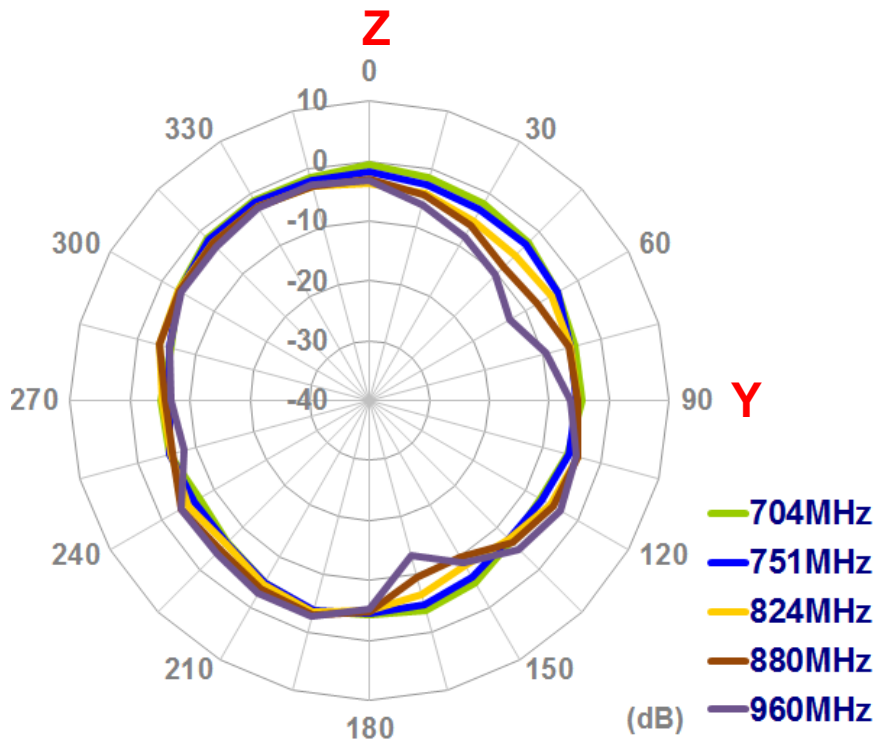

X-Y plane

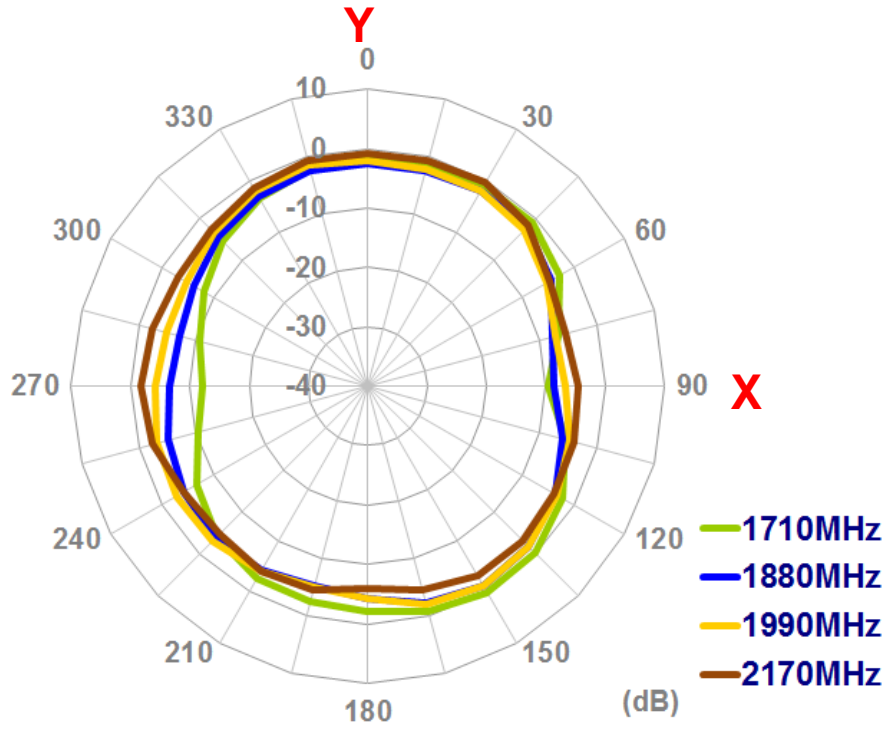

X-Z plane

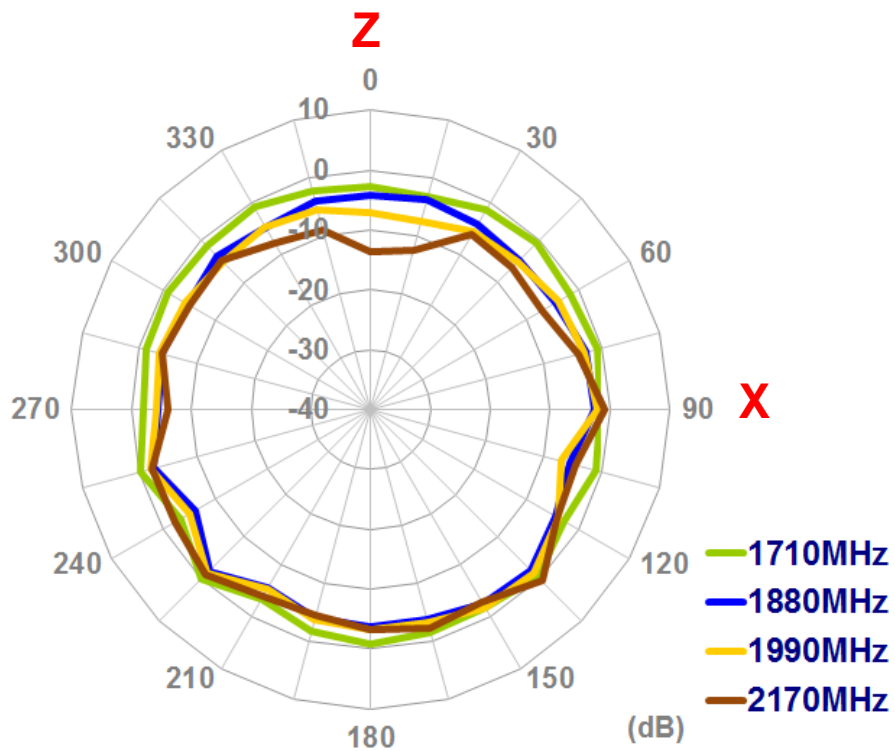

Y-Z plane

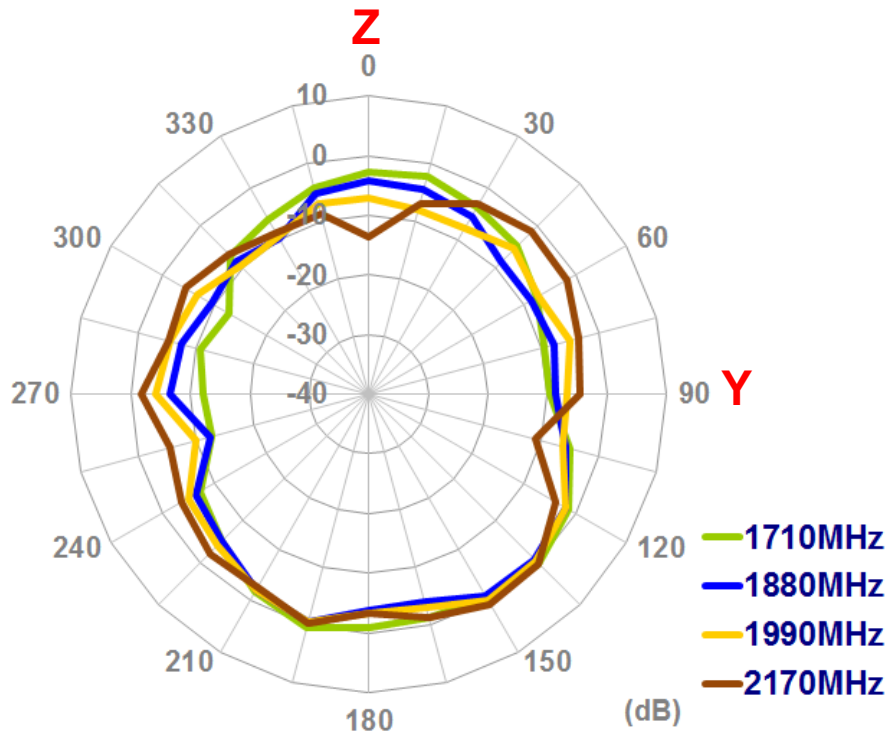

X-Y plane

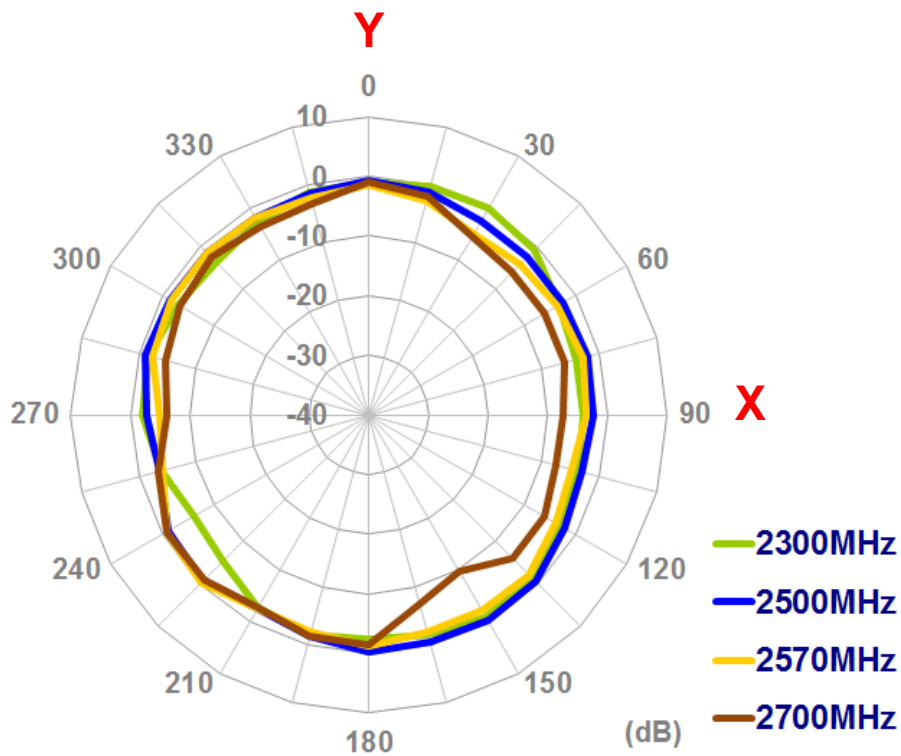

X-Z plane

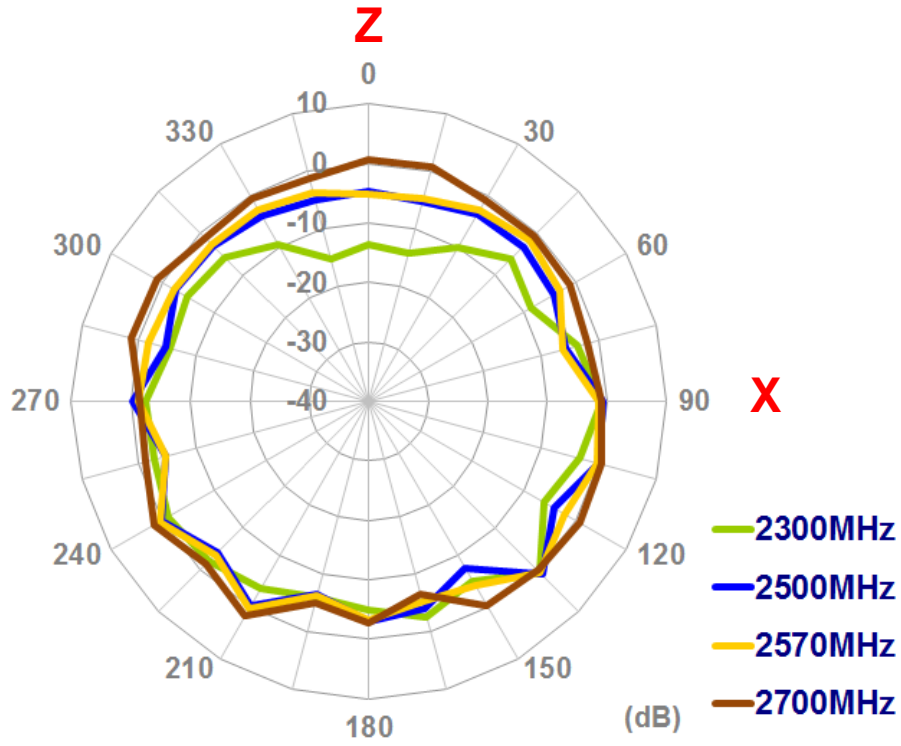

Y-Z plane

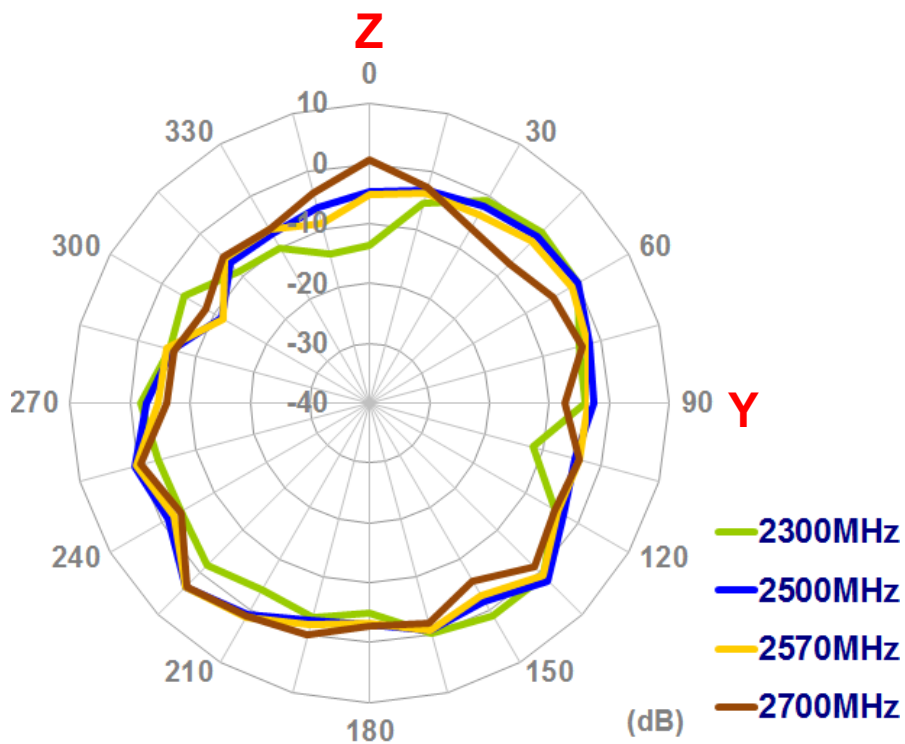

4.3 Antenna Setup – Straight With 15cmX9cm Ground Plane

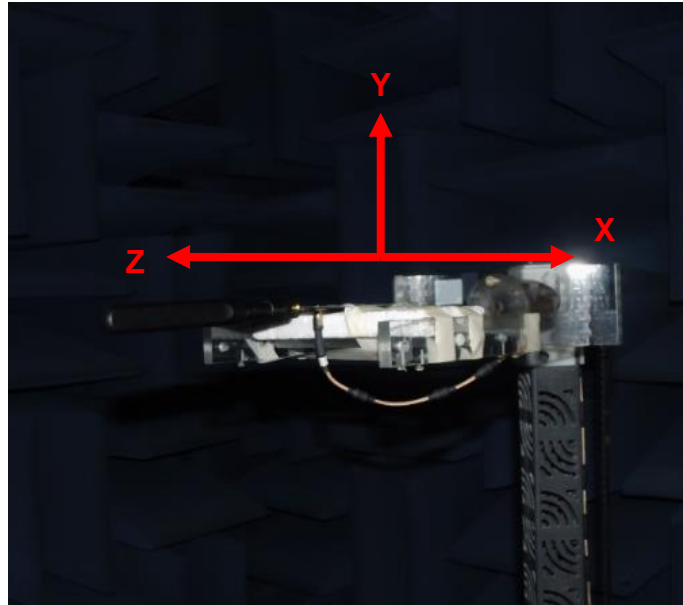

Antenna Straight with 15cm X 9cm ground plane

- **Antenna Radiation Patterns**

X-Y plane

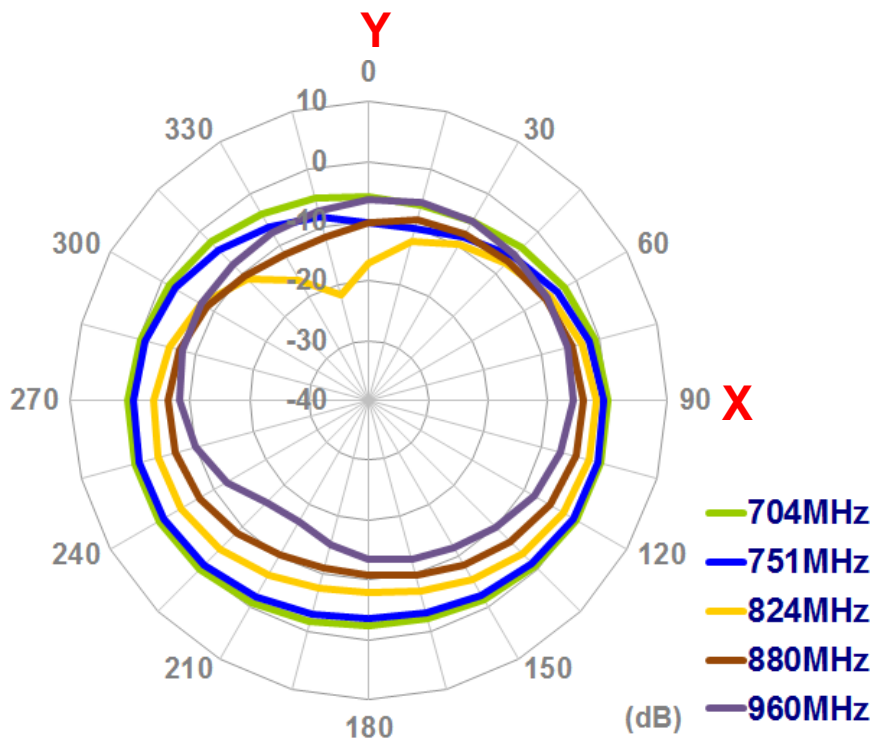

X-Z plane

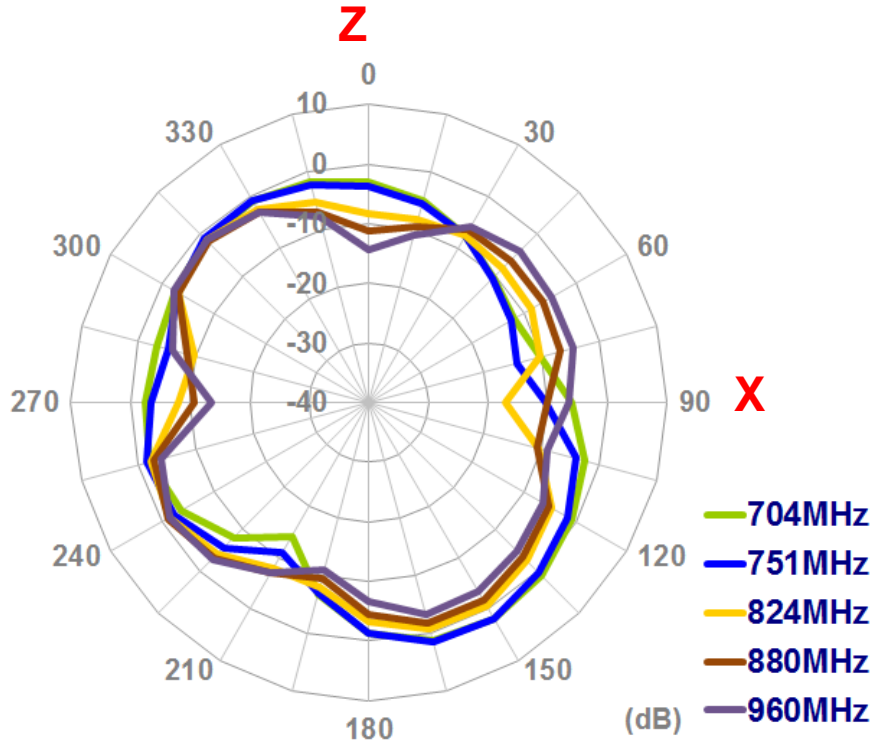

Y-Z plane

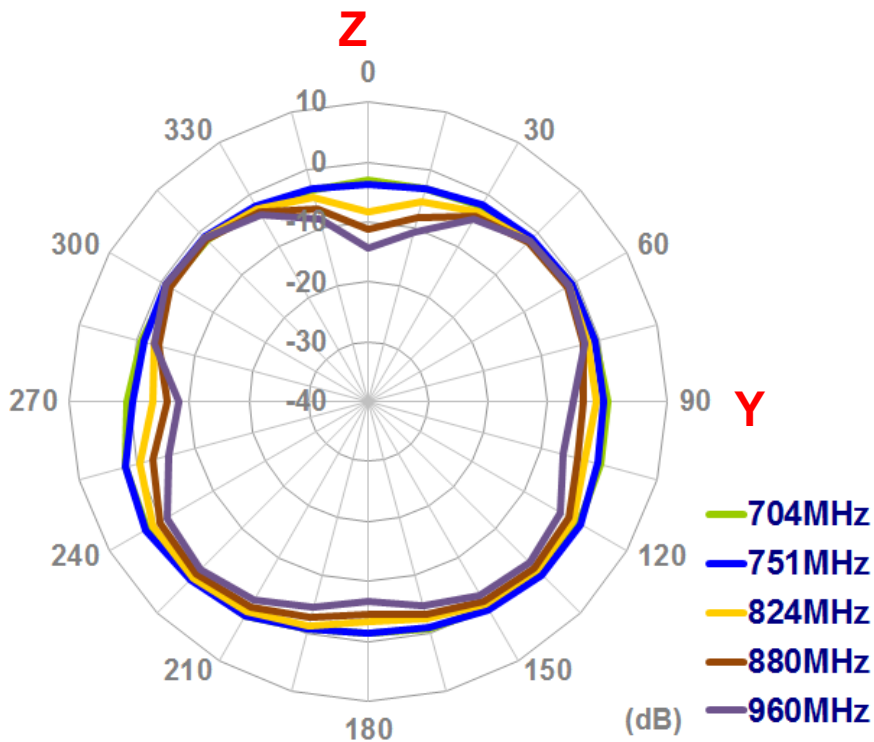

X-Y plane

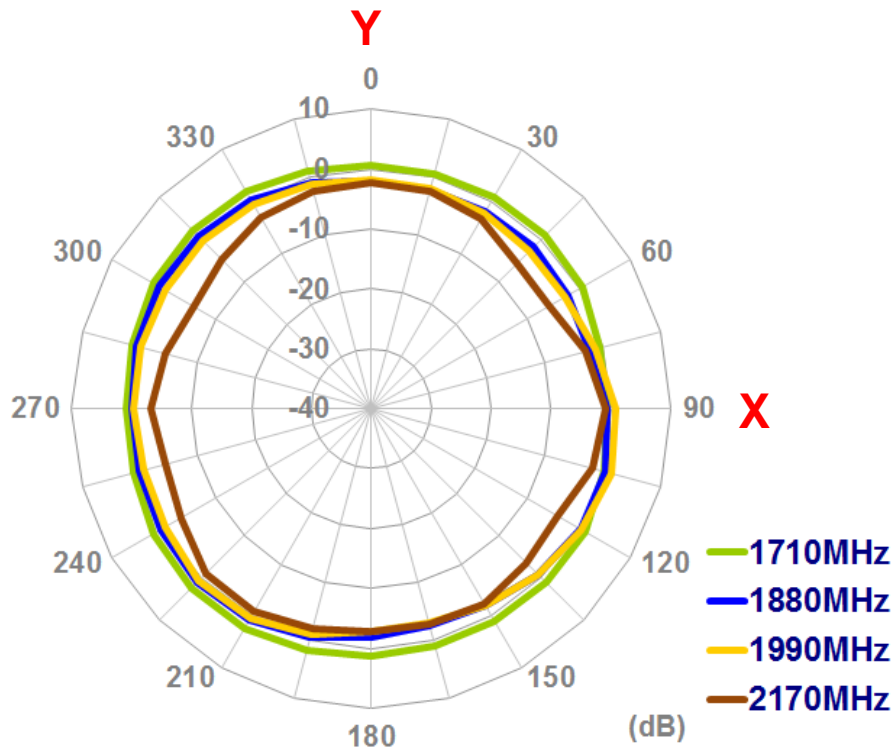

X-Z plane

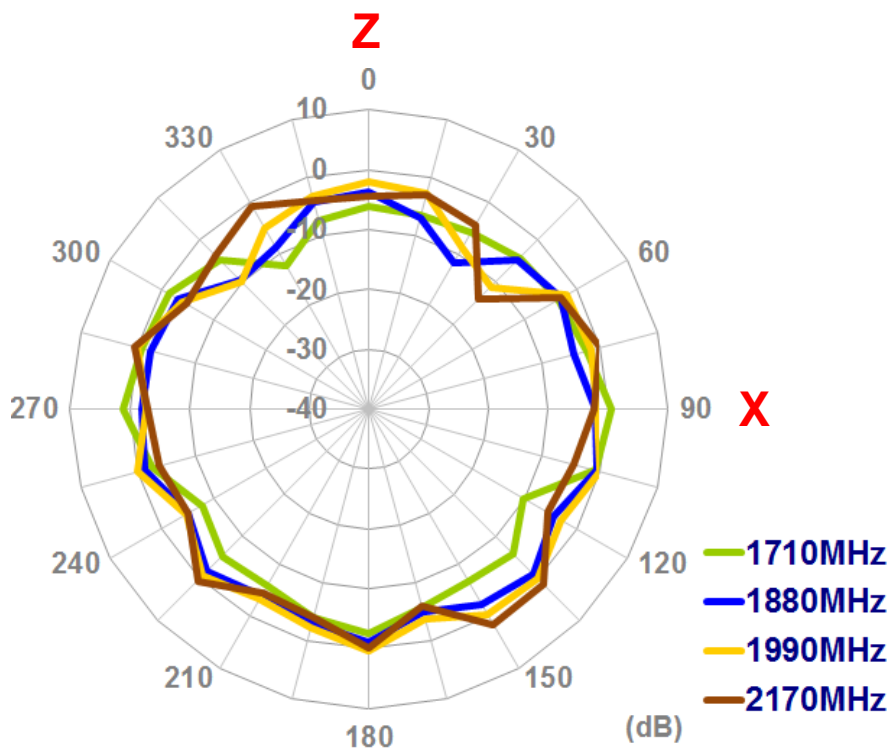

Y-Z plane

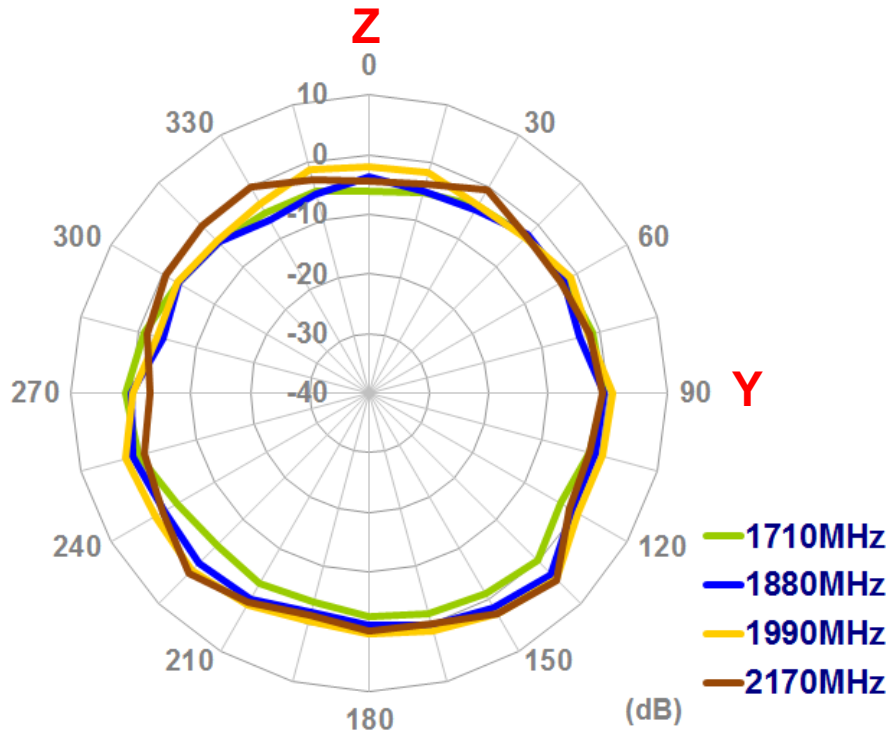

X-Y plane

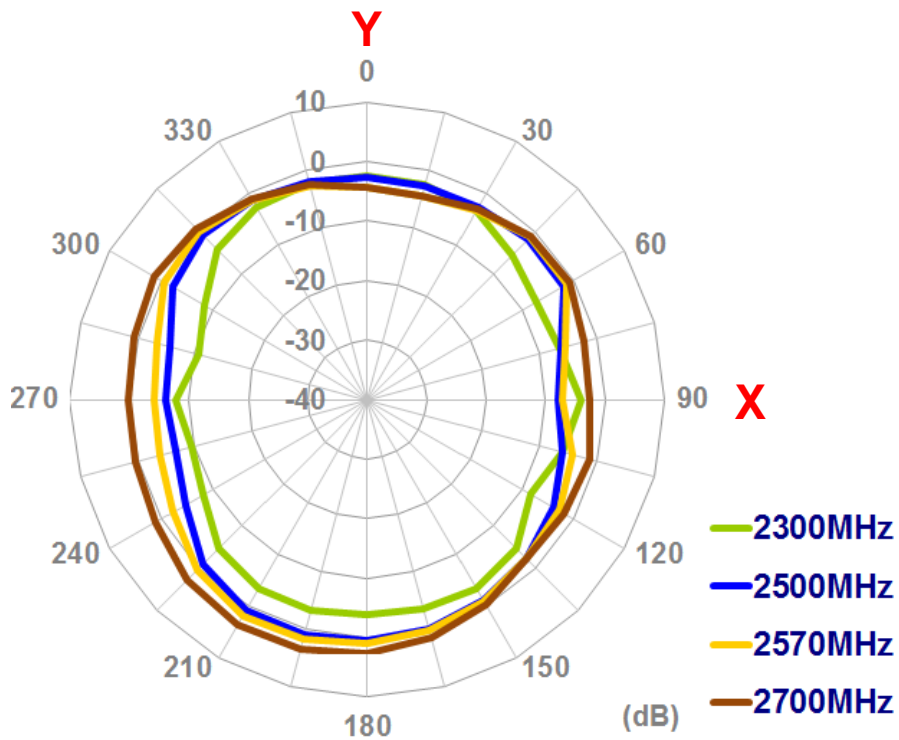

X-Z plane

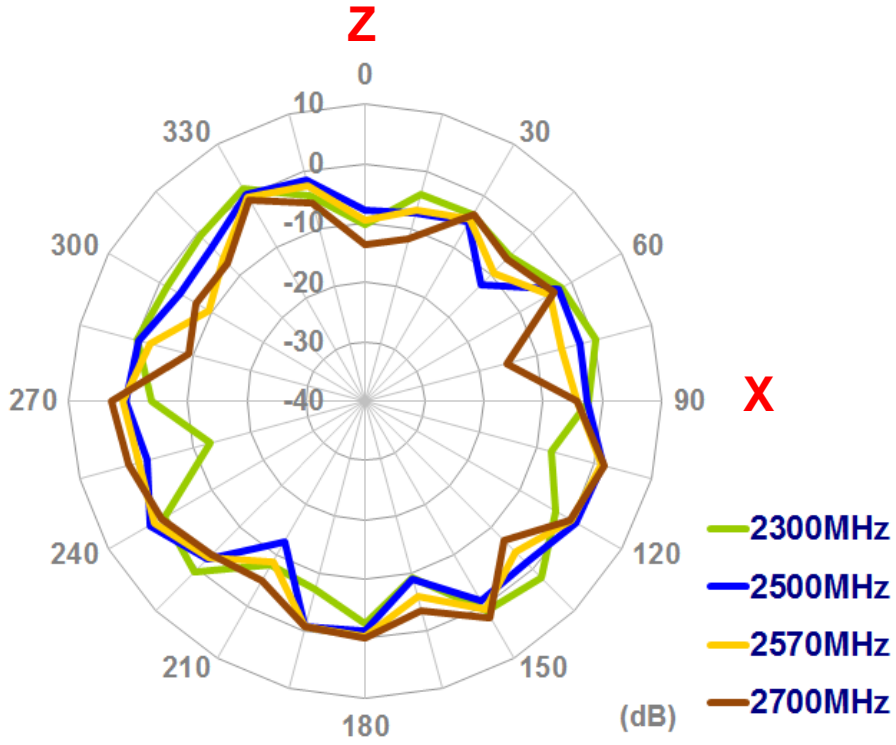

Y-Z plane

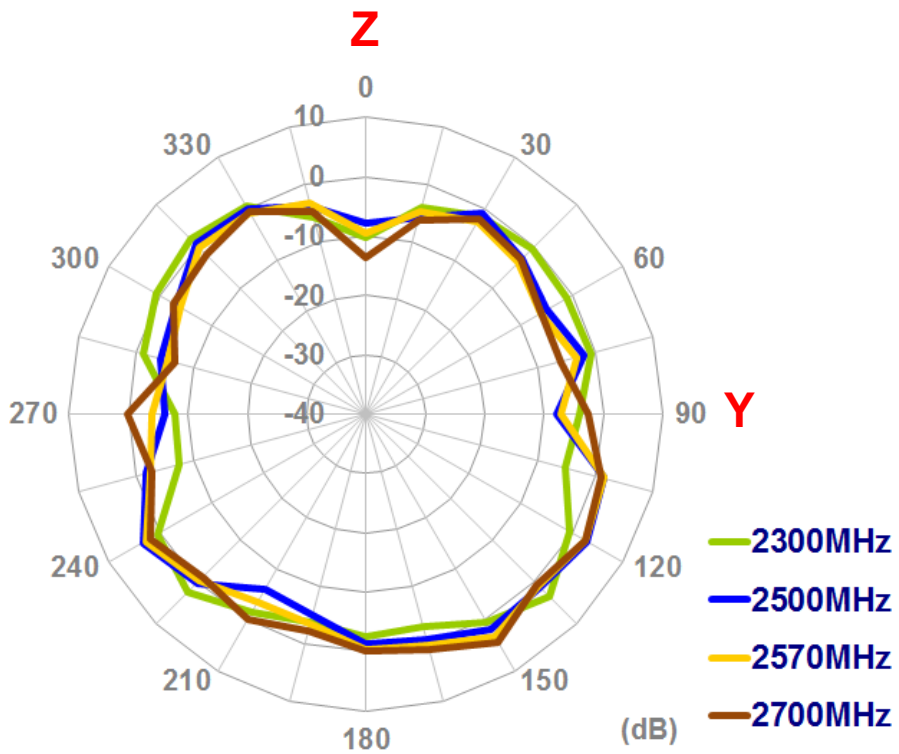

4.4 Antenna Setup – Bent At 90 Degrees With 15cmX9cm Ground Plane

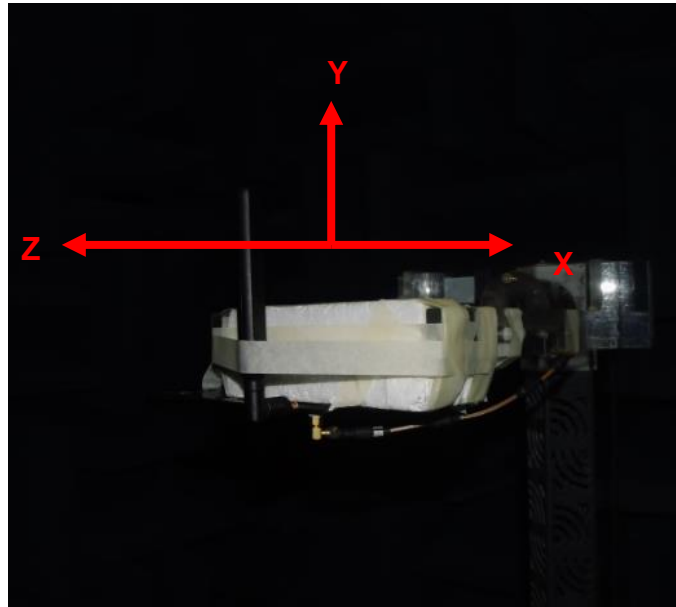

Antenna bent 90 degrees with 15cm X 9cm ground plane

- **Antenna Radiation Patterns**

X-Y plane

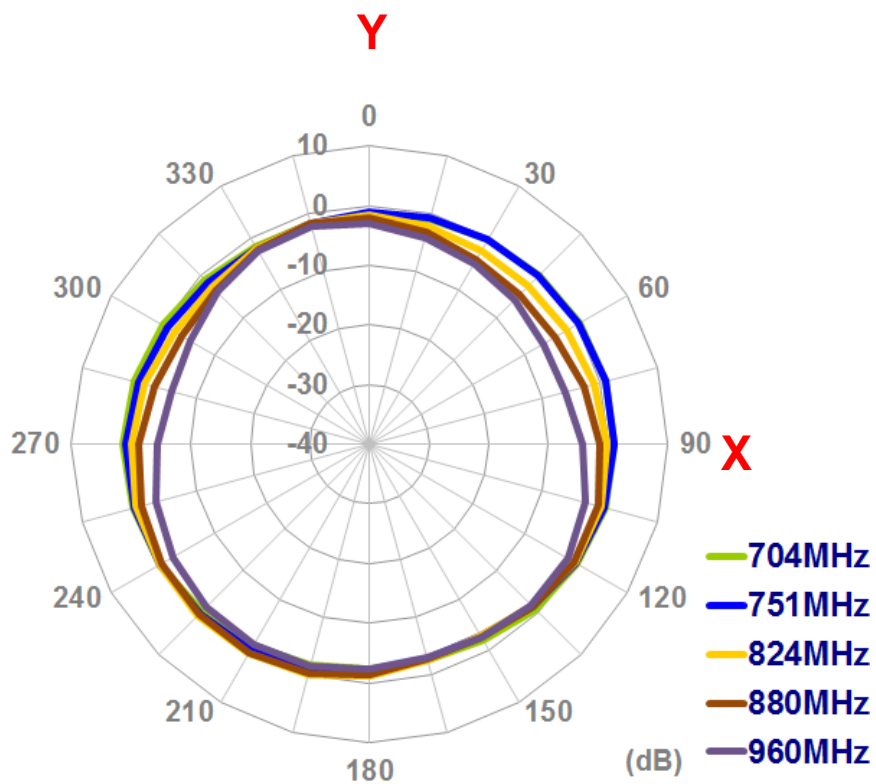

X-Z plane

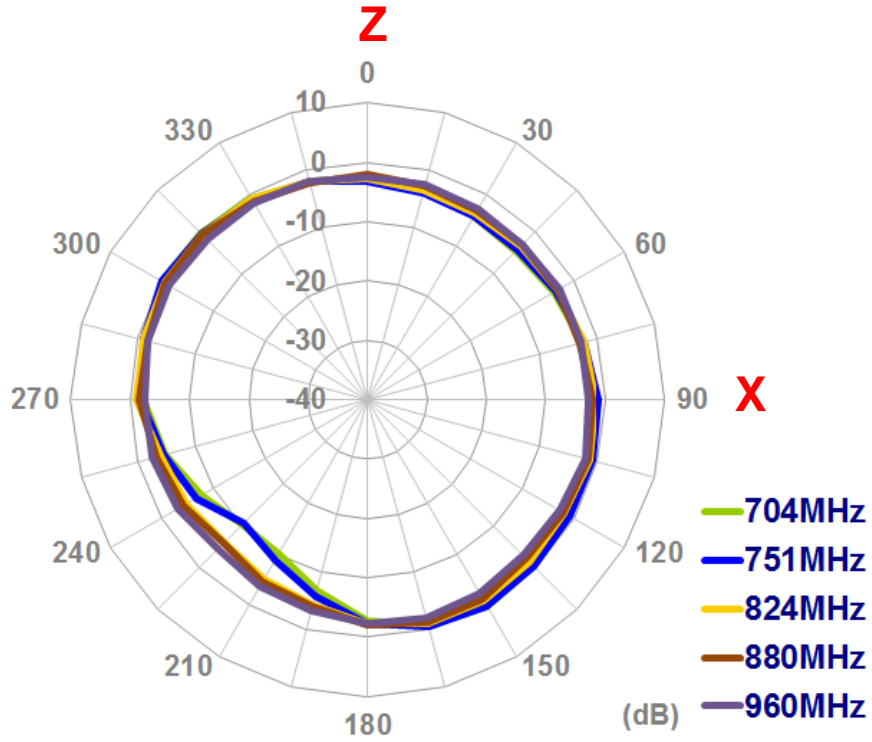

Y-Z plane

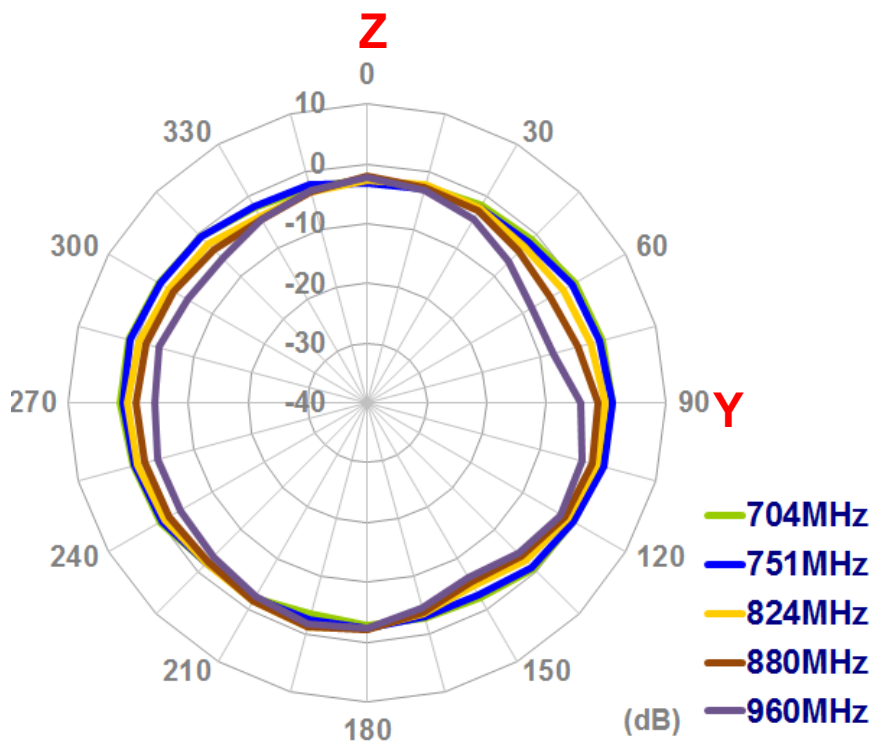

X-Y plane

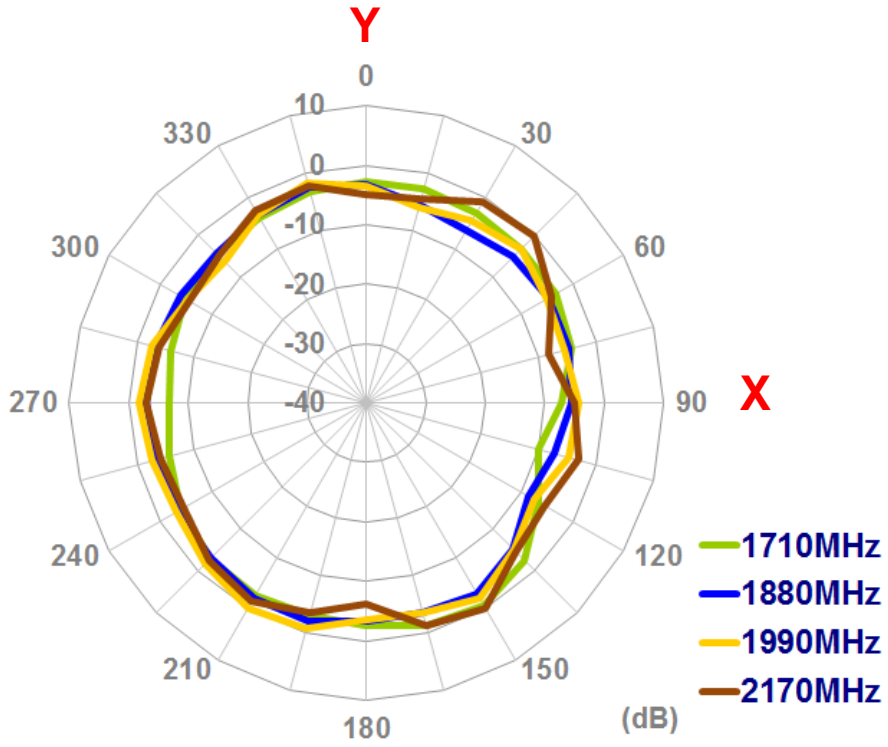

X-Z plane

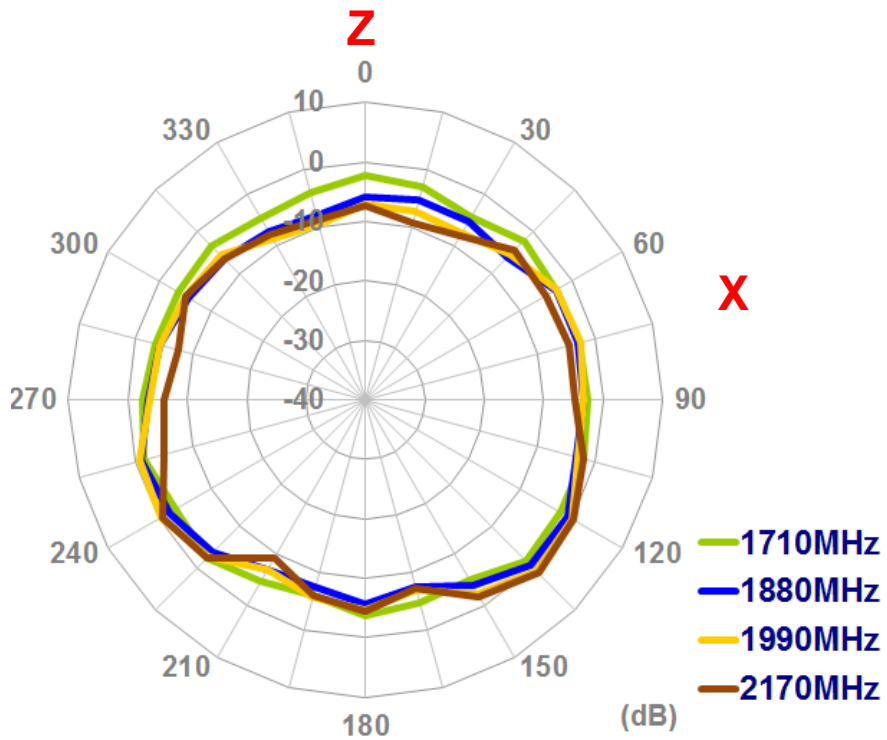

Y-Z plane

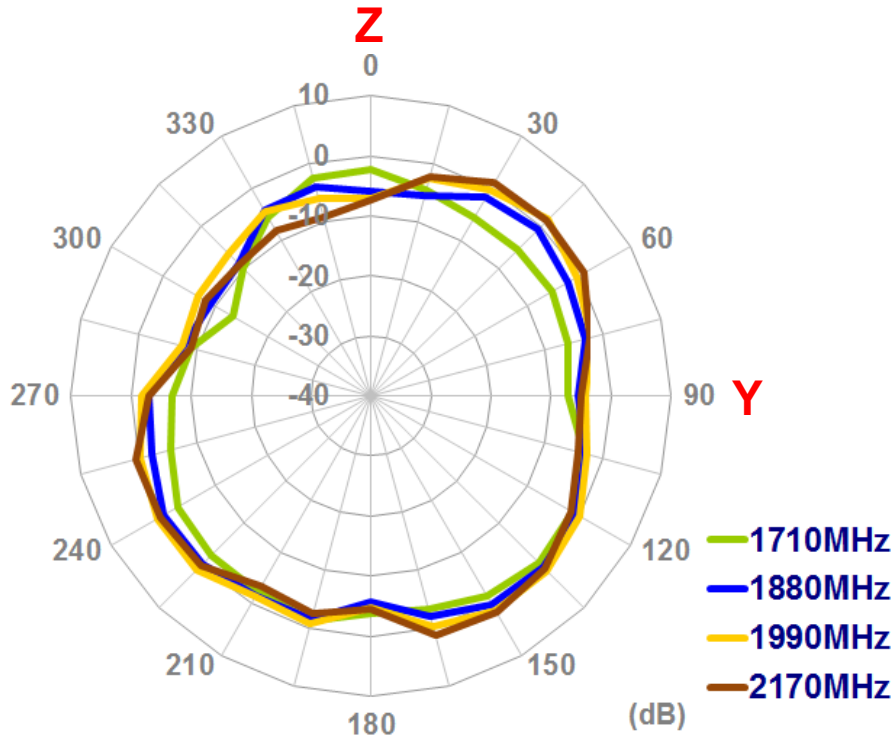

X-Y plane

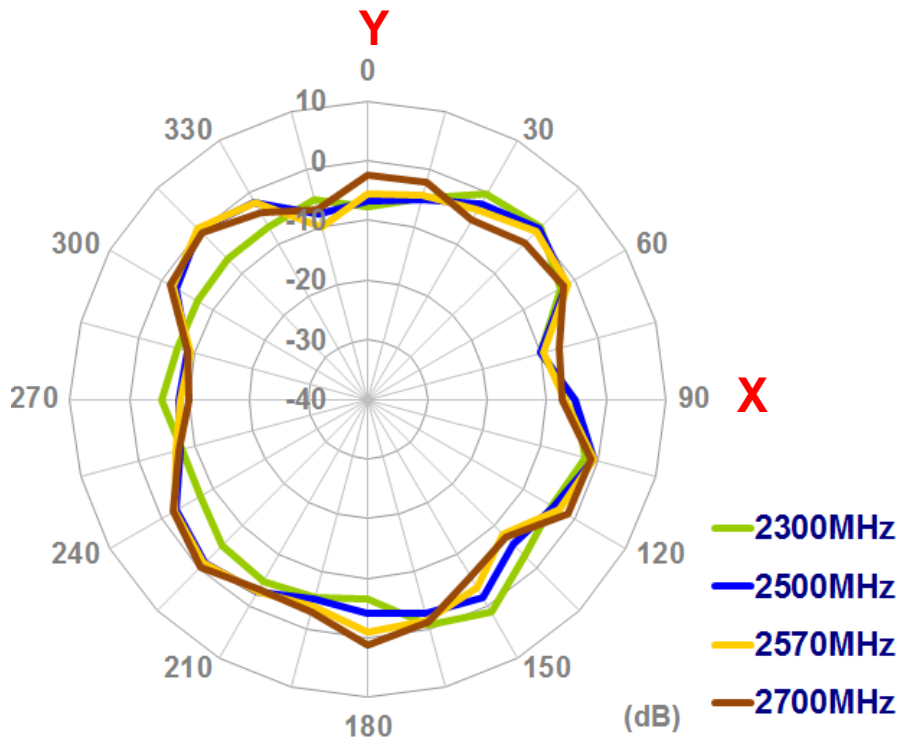

X-Z plane

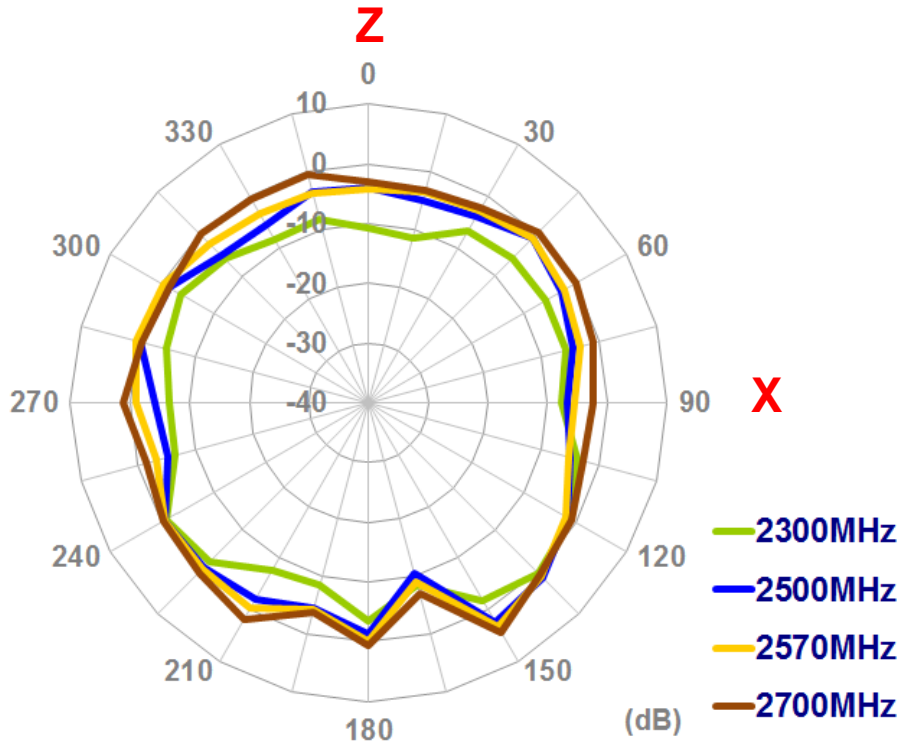

Y-Z plane

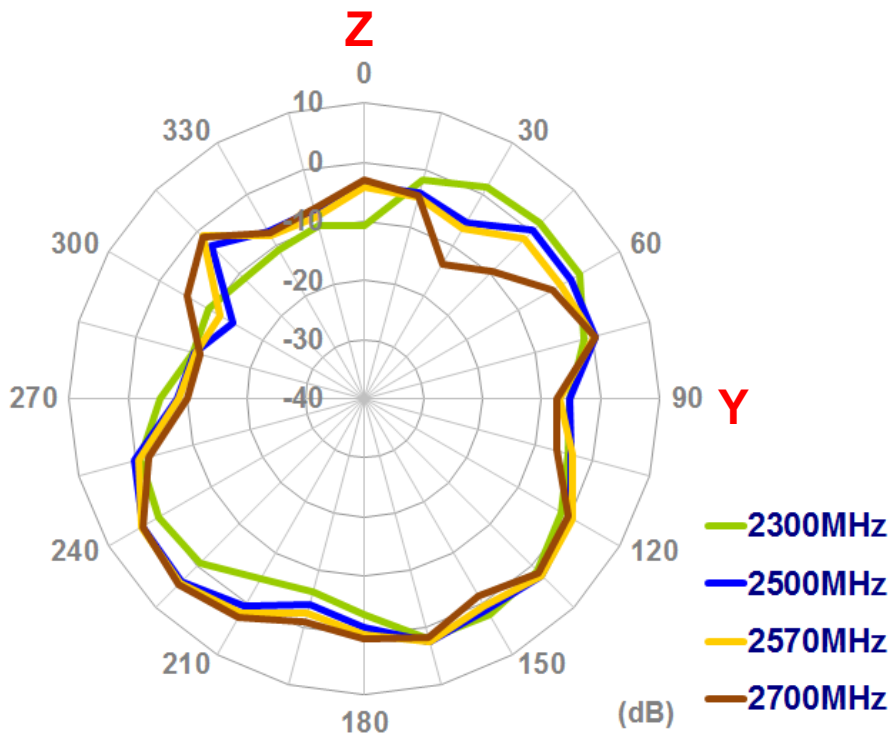

4.5 Antenna Setup – Straight With 30cmX30cm Ground

Plane Edge

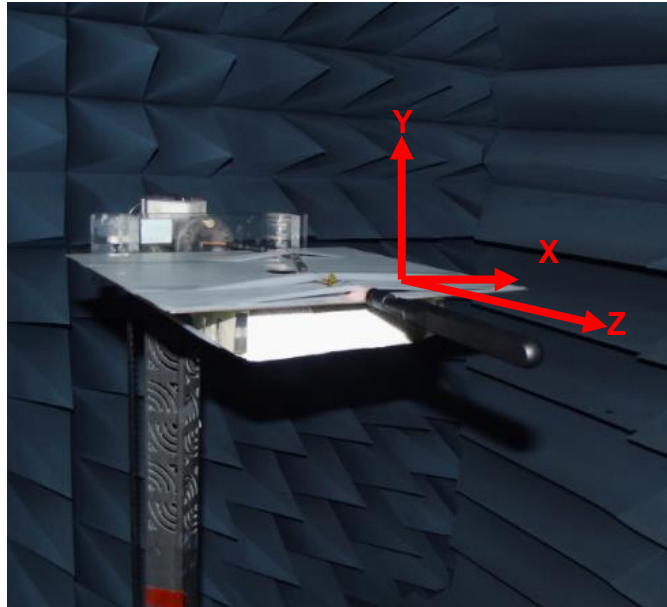

Antenna straight with 30cm X 30cm ground plane edge

- **Antenna Radiation Patterns**

X-Y plane

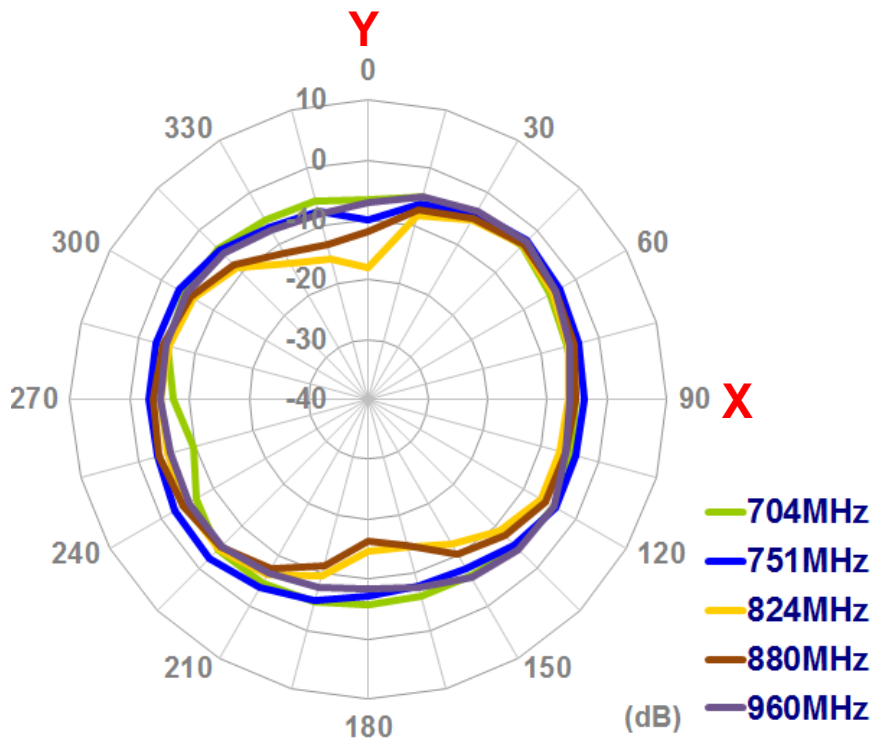

X-Z plane

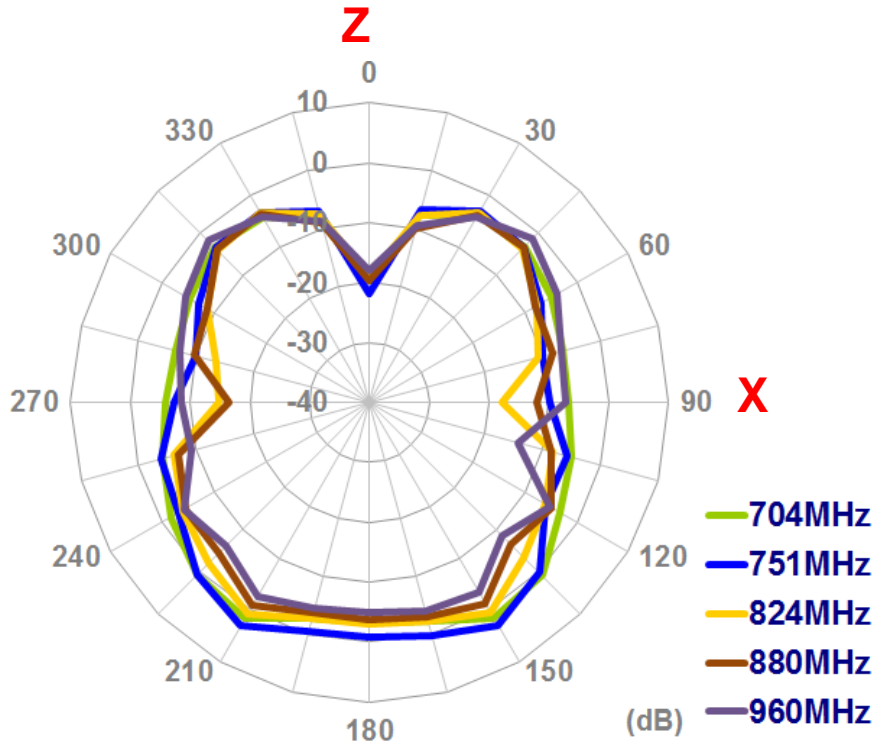

Y-Z plane

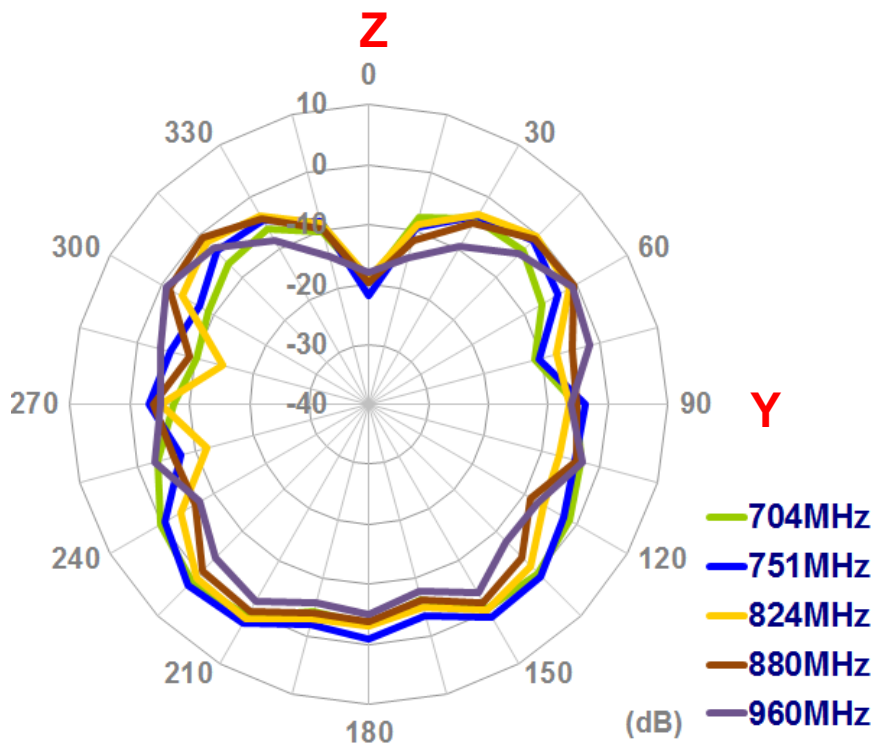

X-Y plane

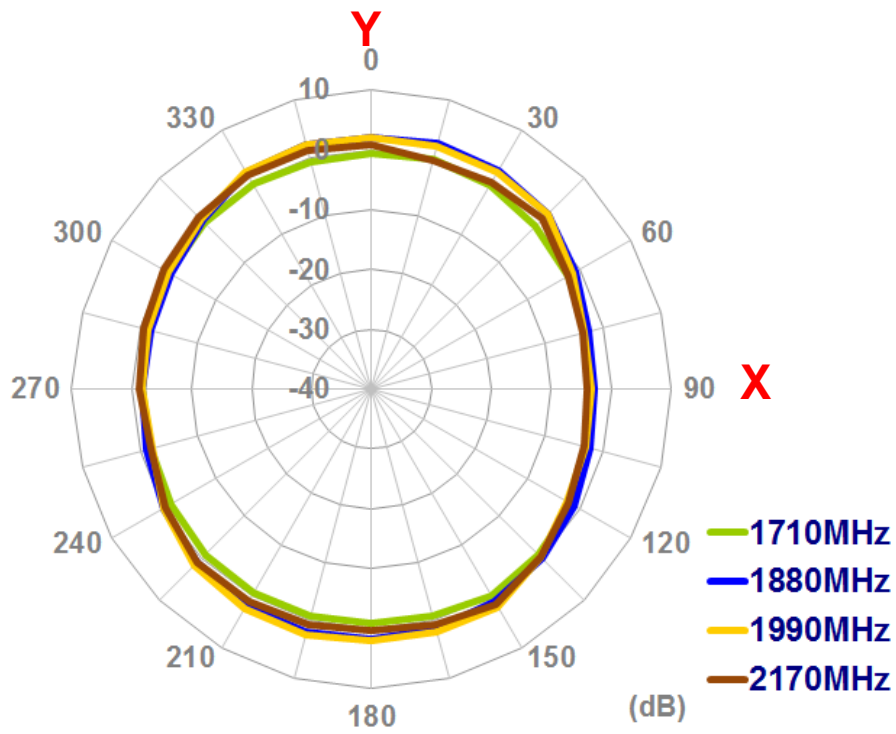

X-Z plane

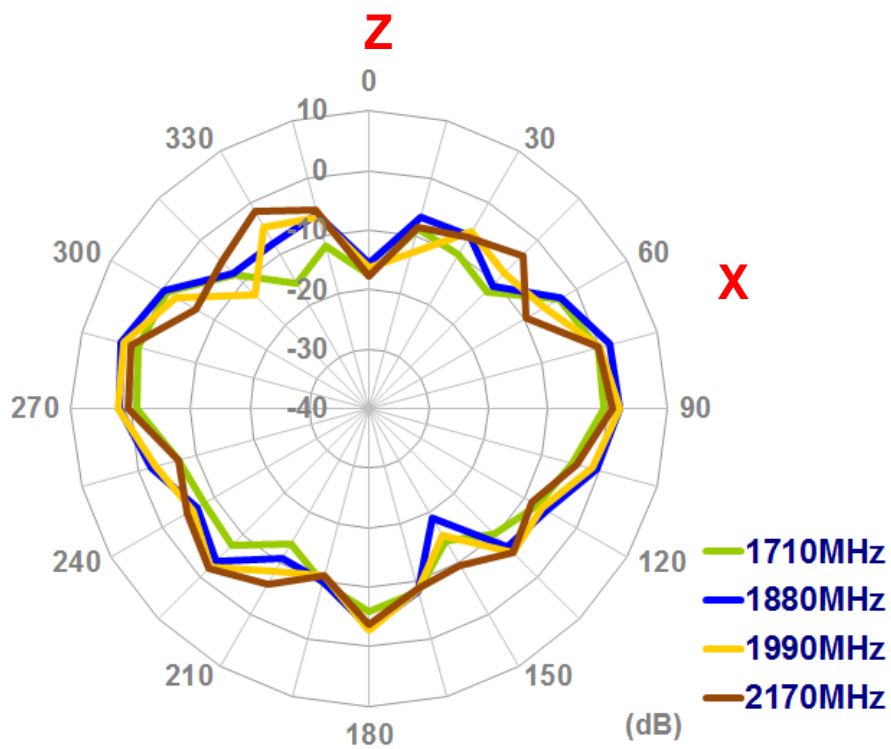

Y-Z plane

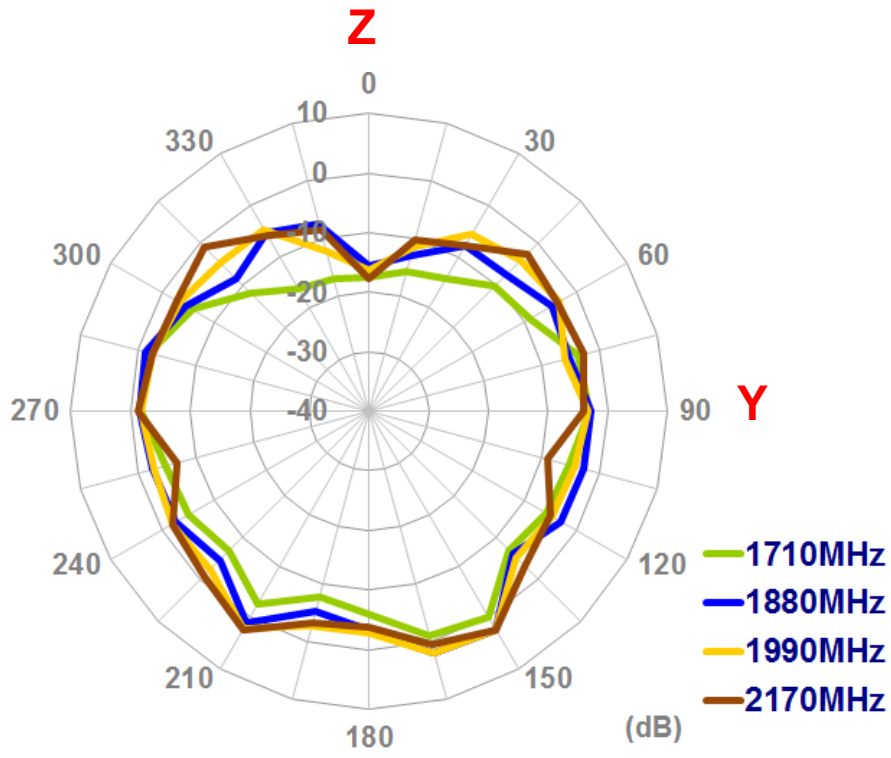

X-Y plane

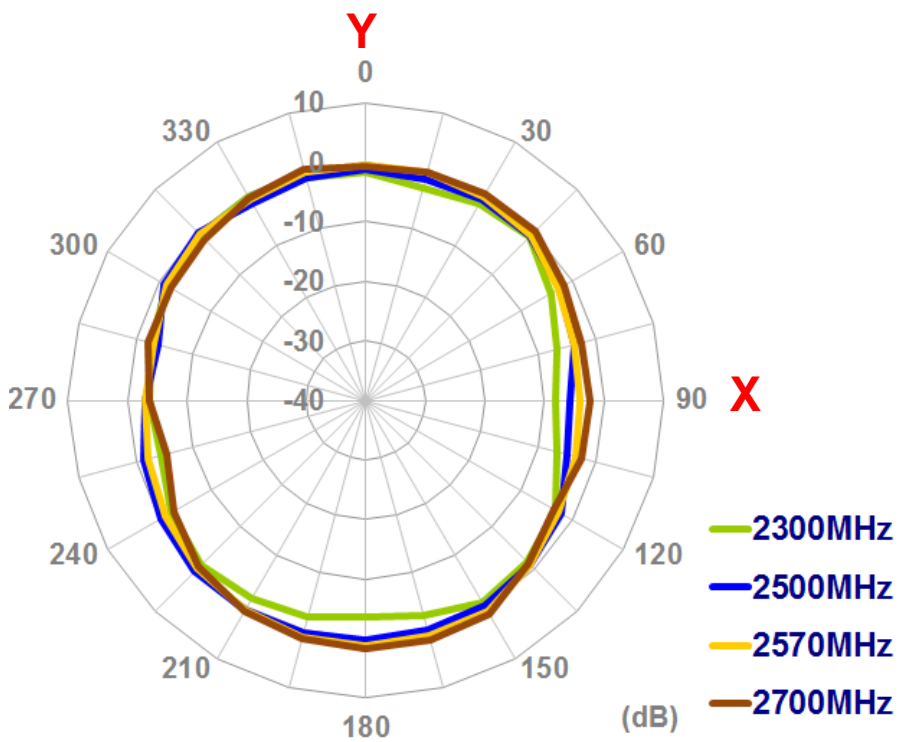

X-Z plane

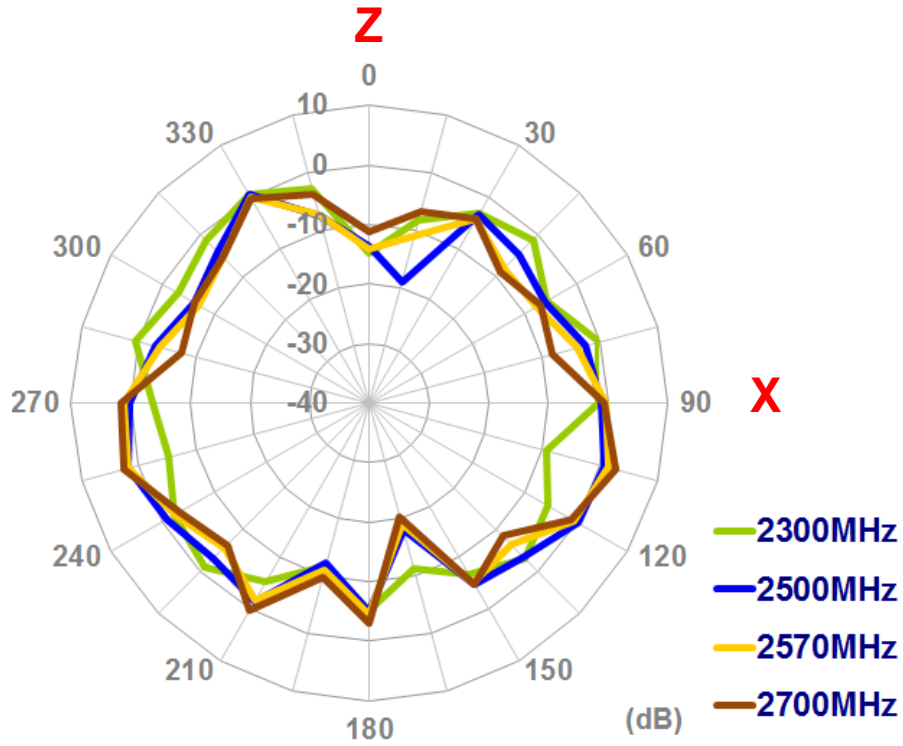

Y-Z plane

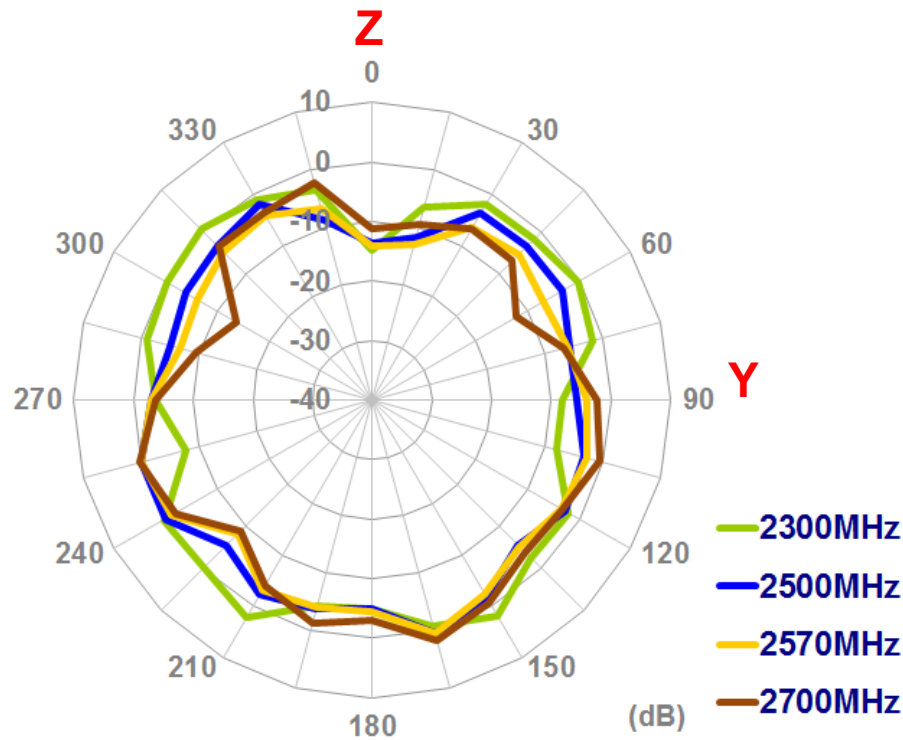

4.6 Antenna Setup – Bent At 90 Degrees With 30cmX30cm Ground Plane Edge

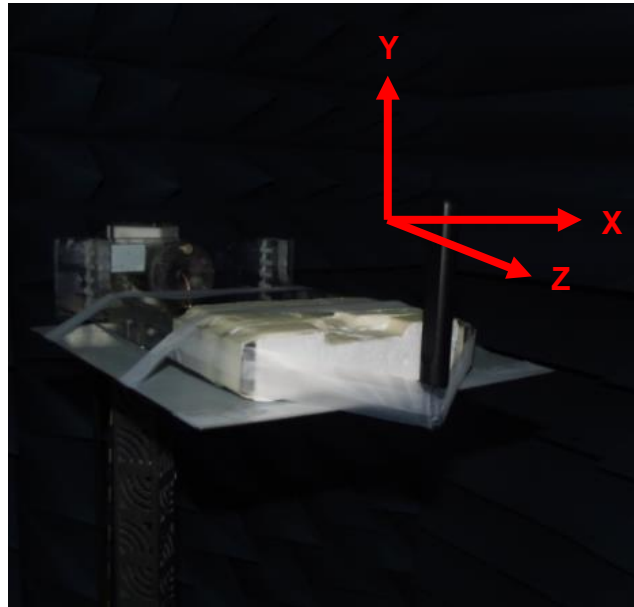

Antenna bent 90 degrees with 30cm X 30cm ground plane edge

- **Antenna Radiation Patterns**

X-Y plane

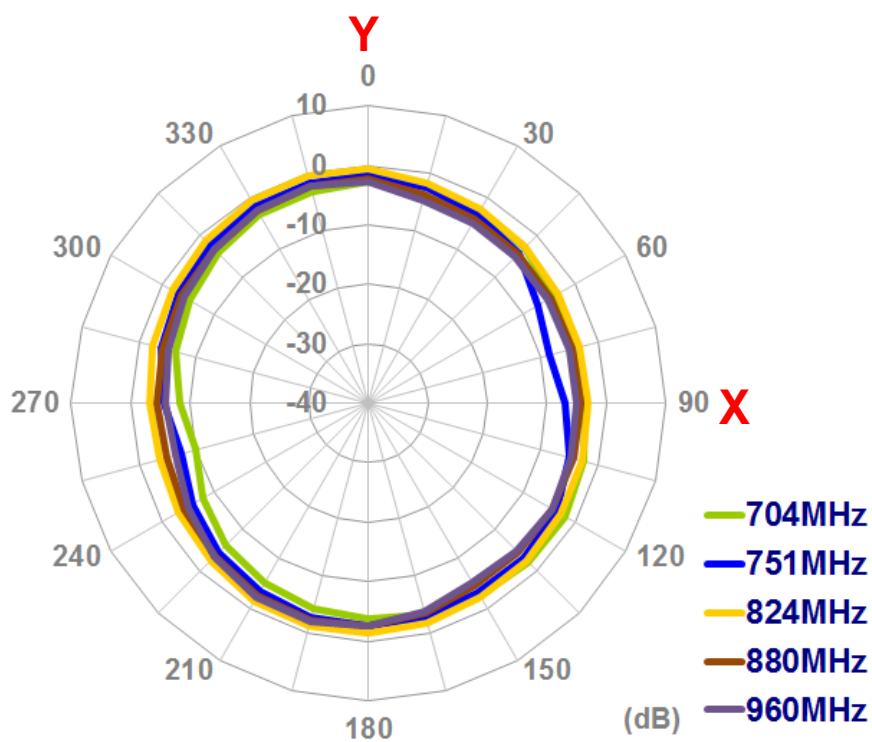

X-Z plane

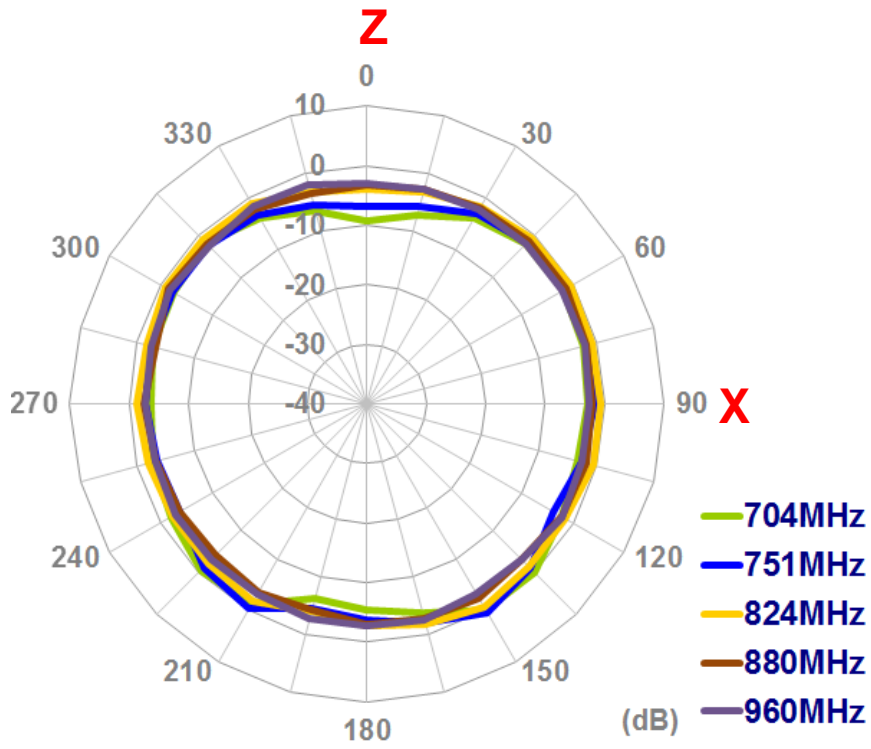

Y-Z plane

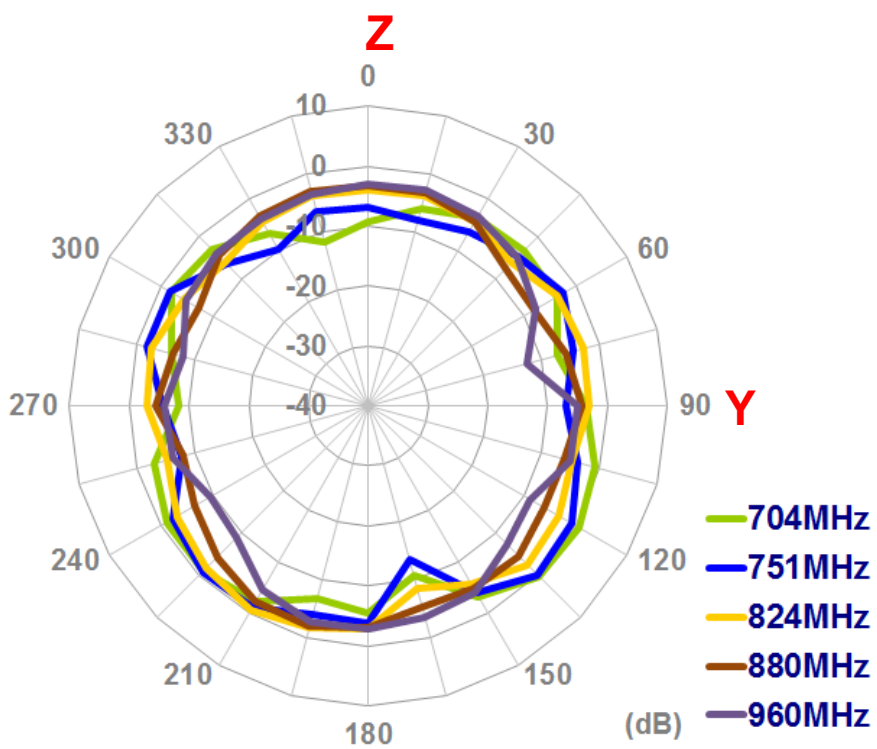

X-Y plane

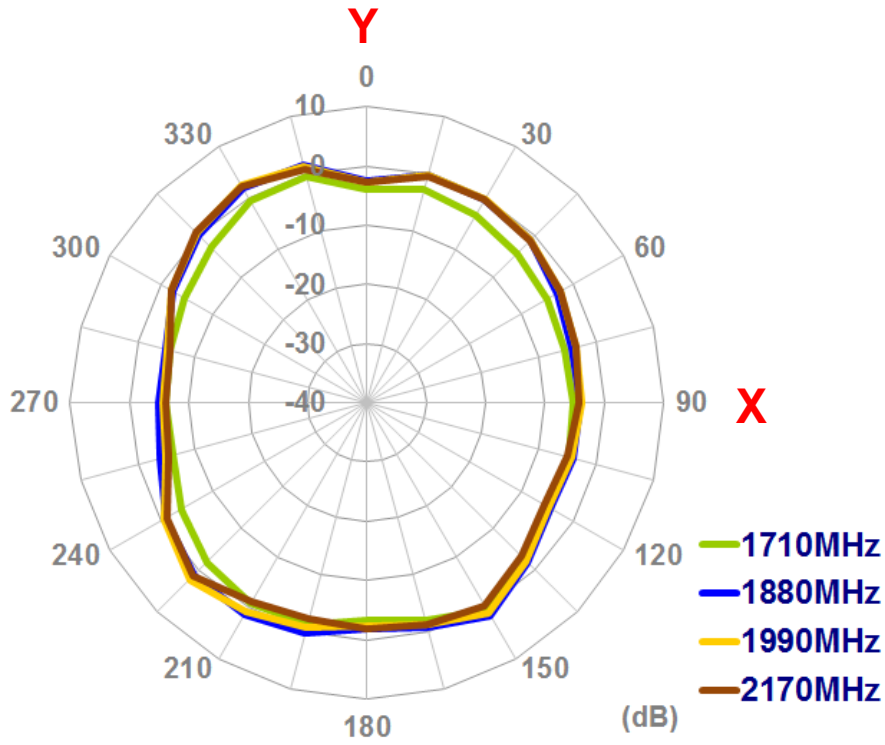

X-Z plane

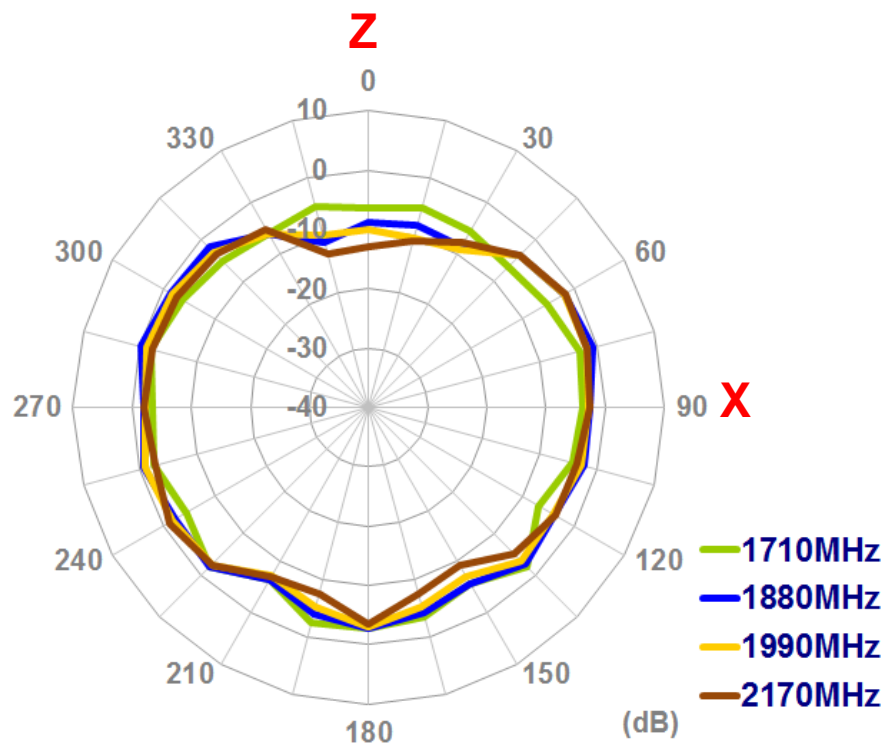

Y-Z plane

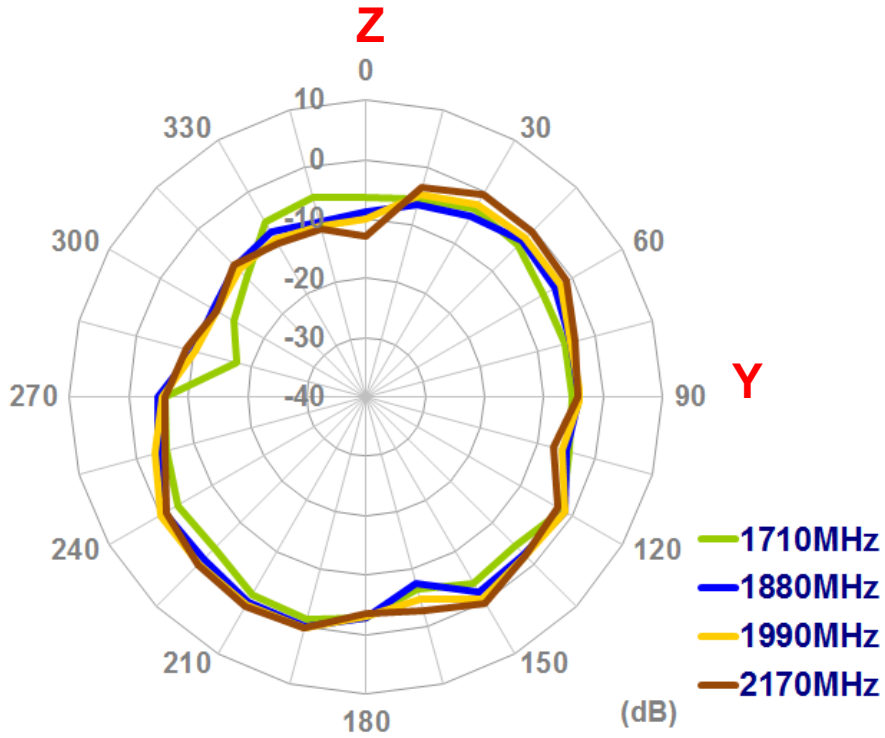

X-Y plane

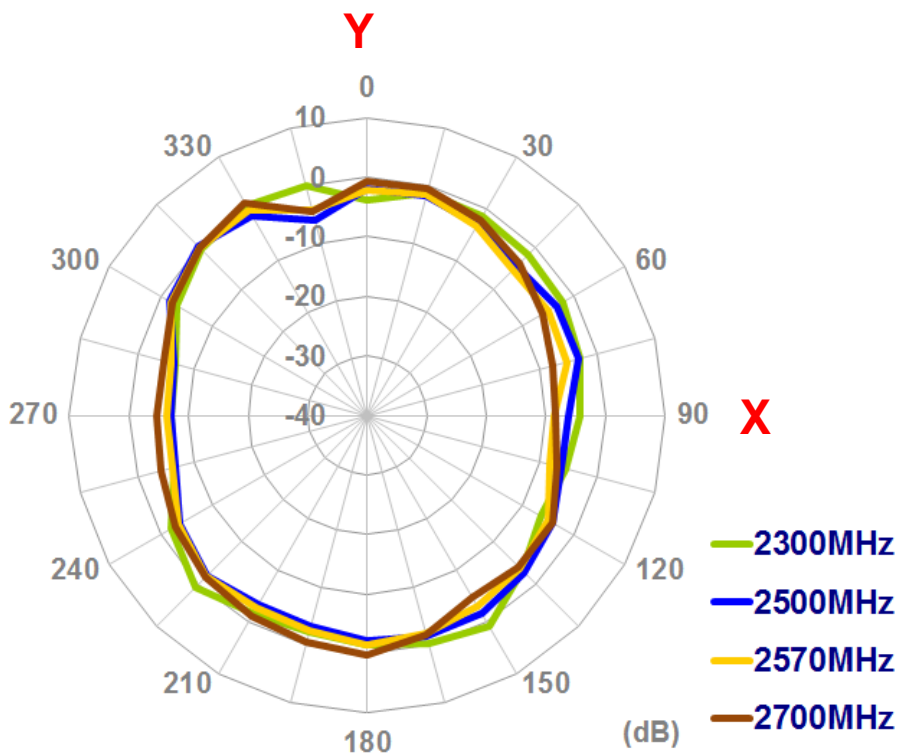

X-Z plane

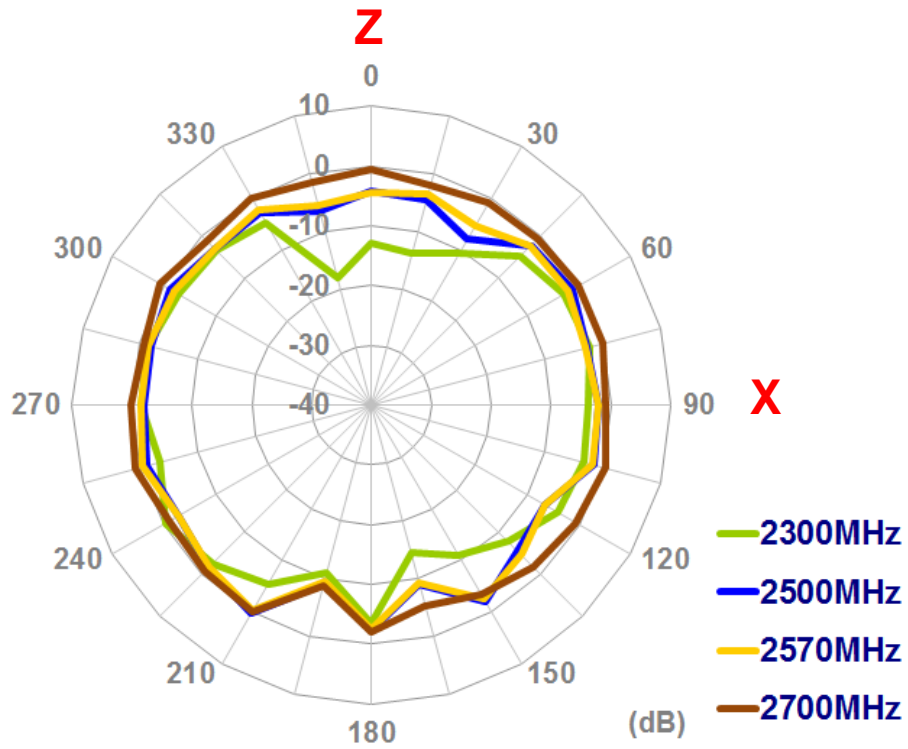

Y-Z plane

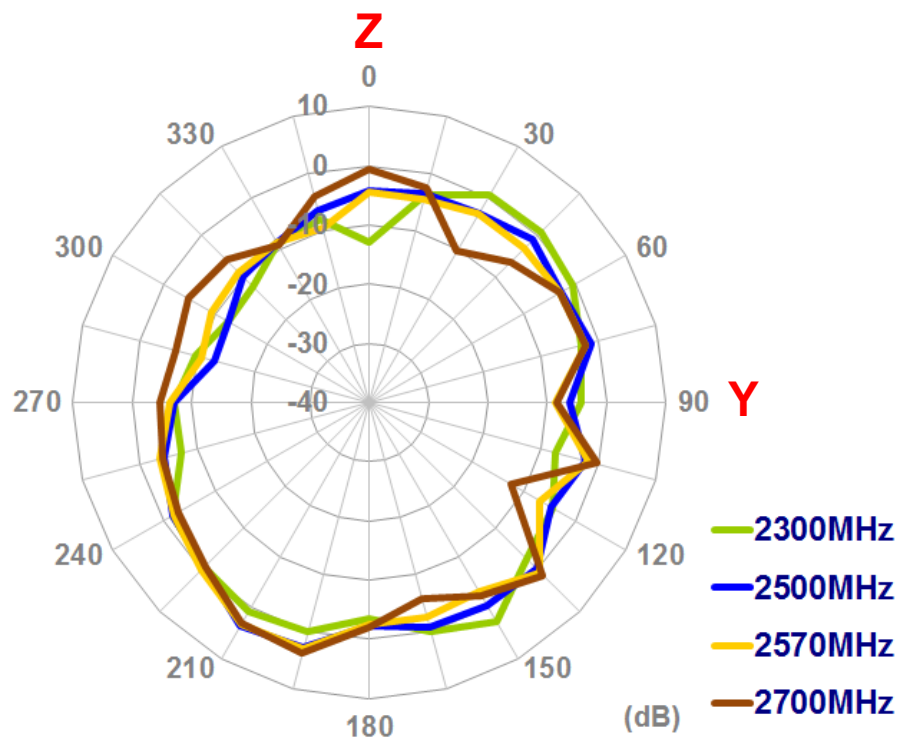

4.7 Antenna Setup – Straight with 30cmX30cm Ground Plane Center

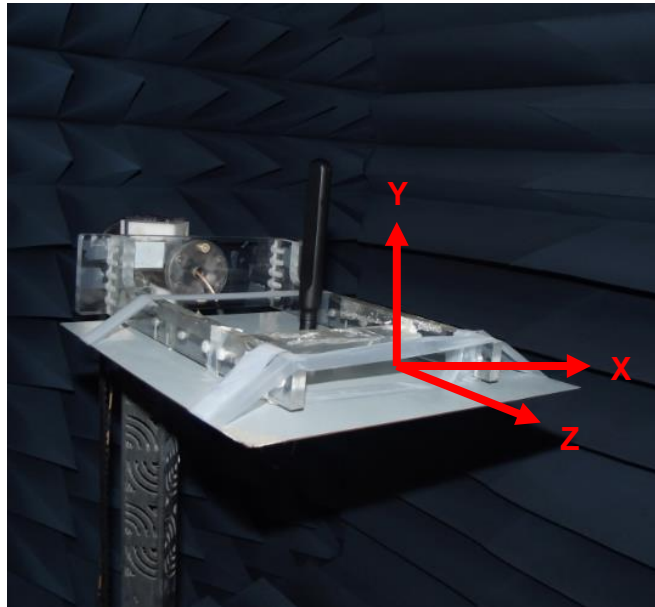

Antenna straight with 30cm x 30cm ground plane center

- **Antenna Radiation Patterns**

X-Y plane

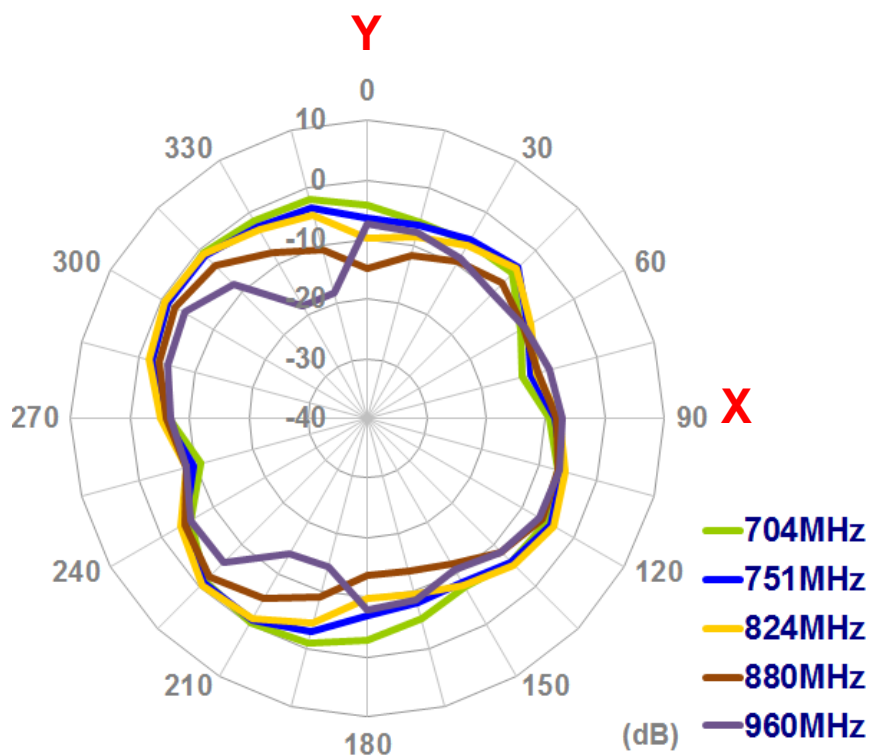

X-Z plane

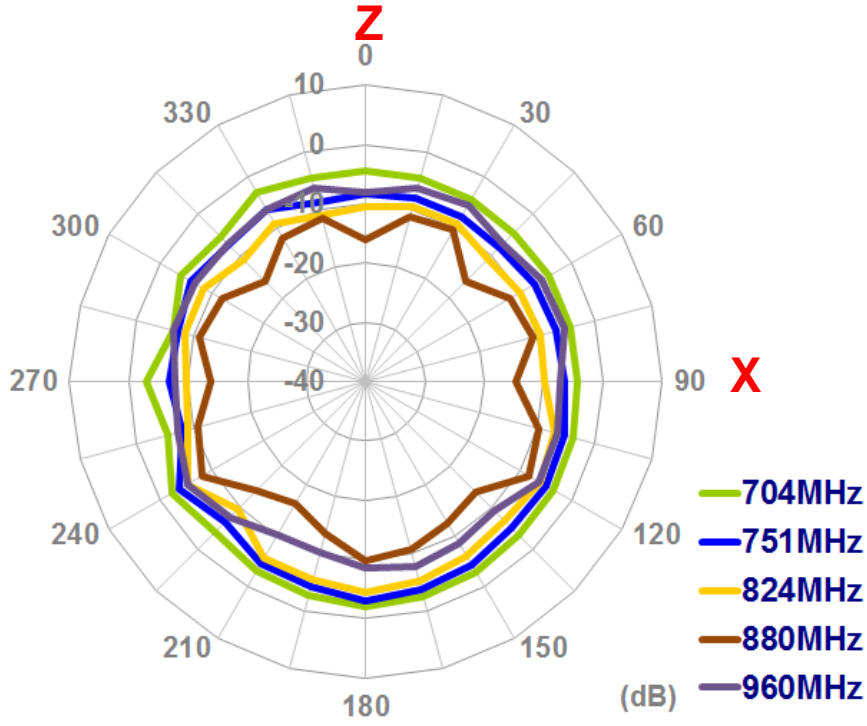

Y-Z plane

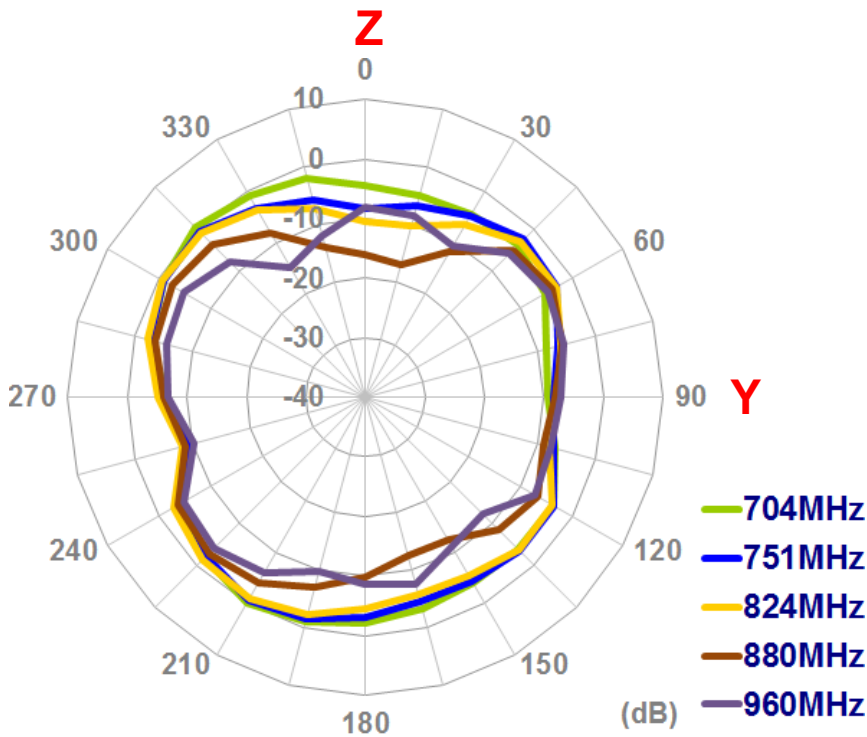

X-Y plane

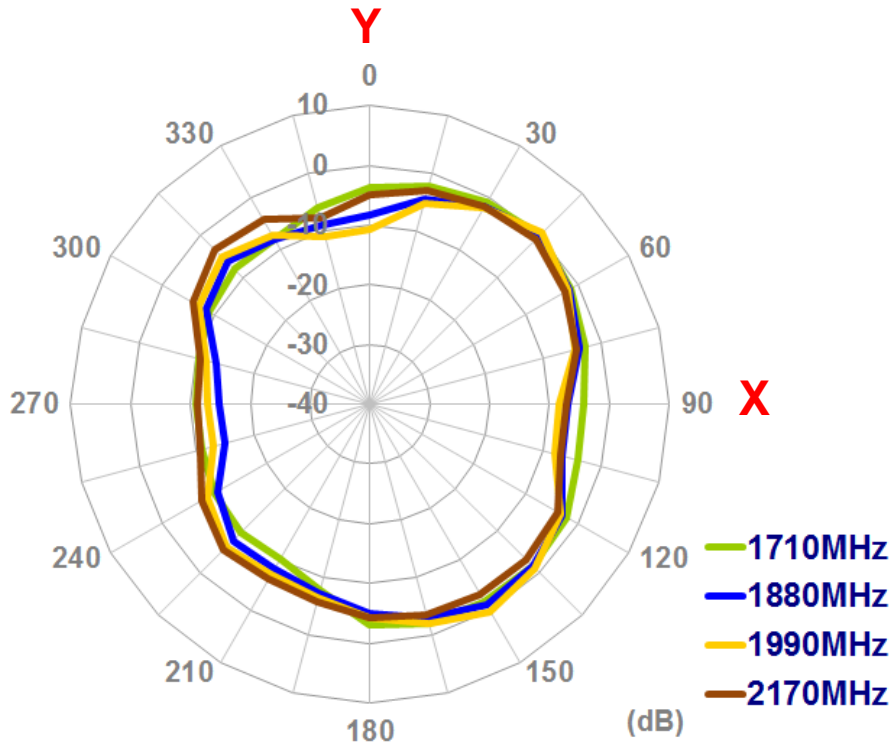

X-Z plane

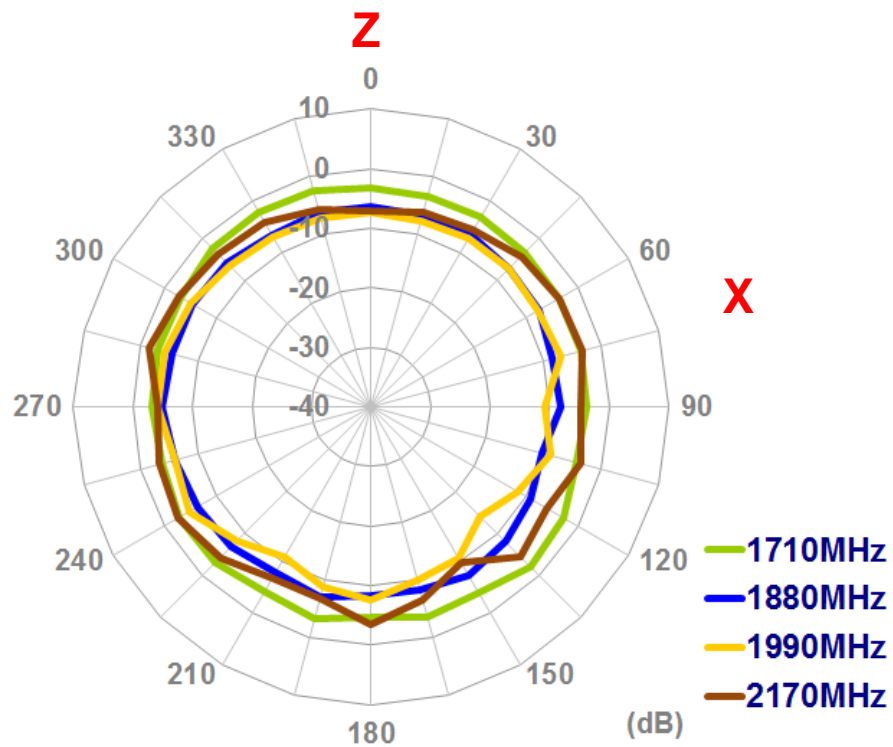

Y-Z plane

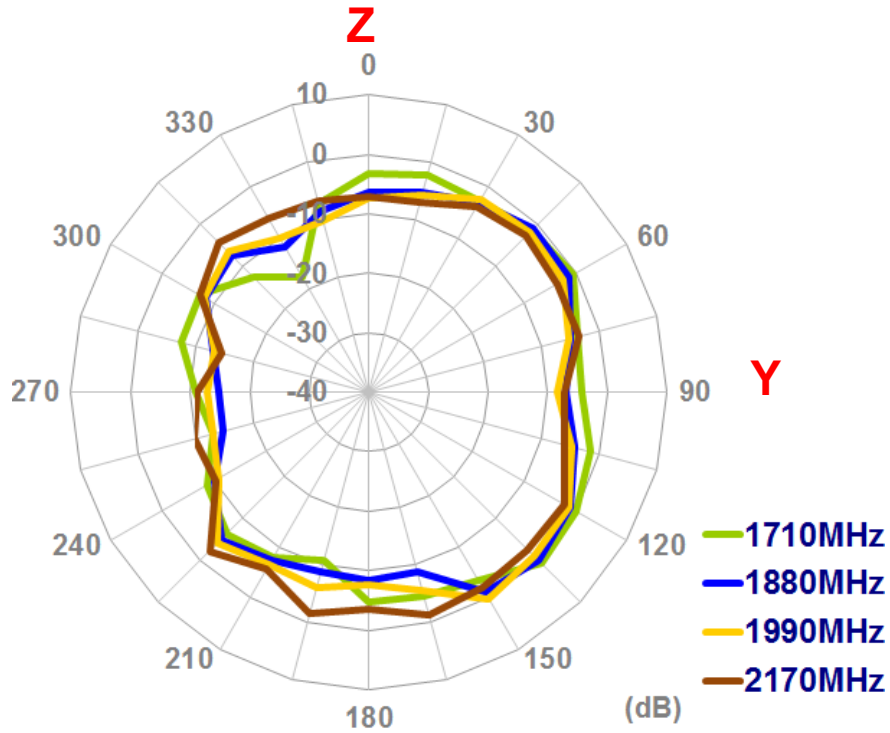

X-Y plane

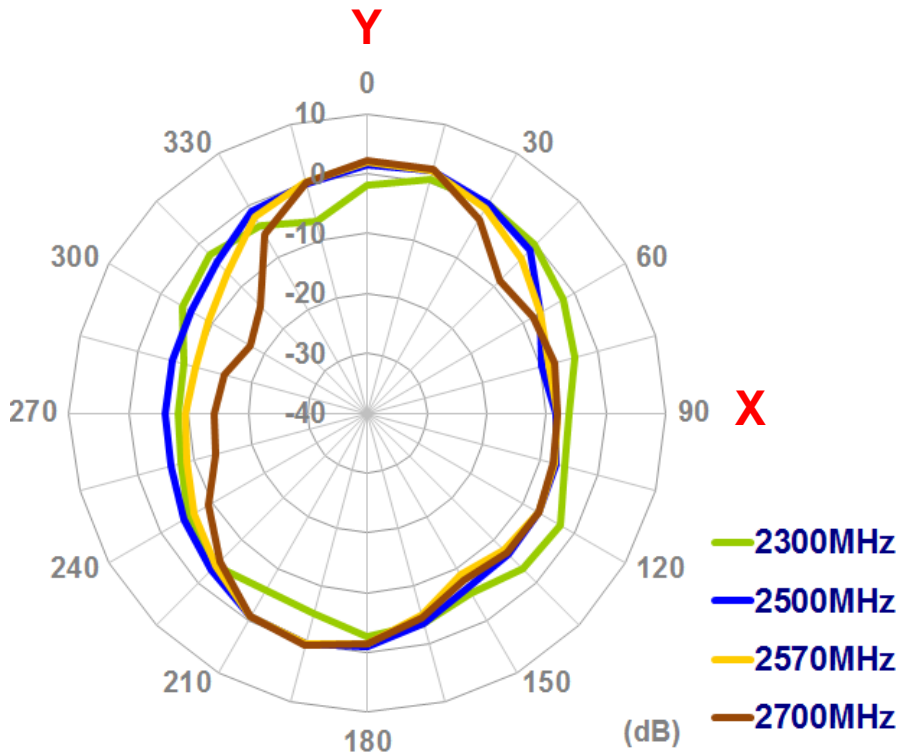

X-Z plane

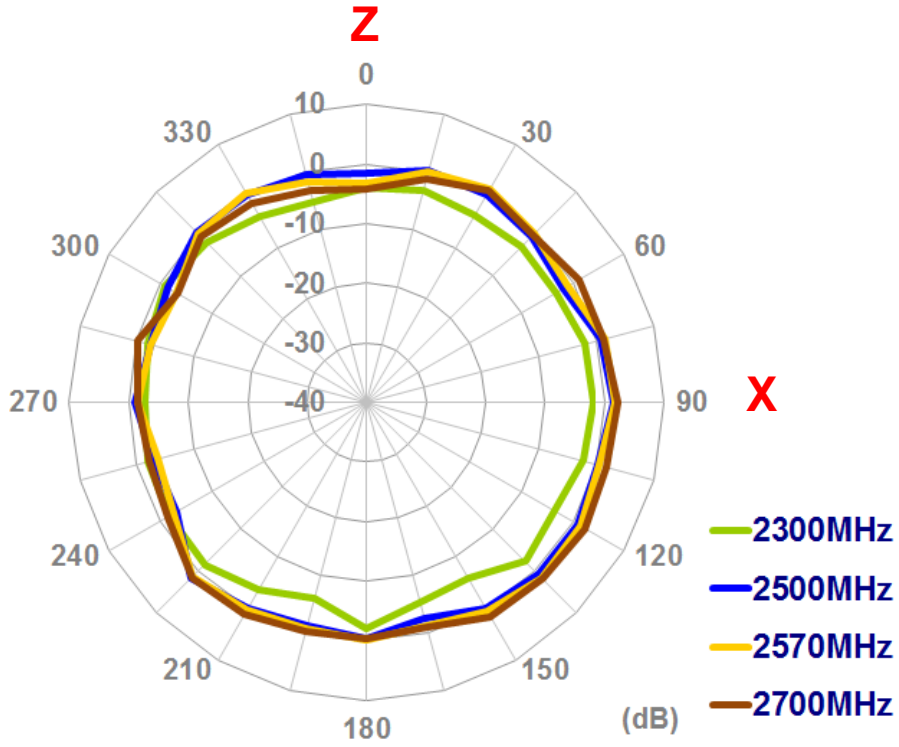

Y-Z plane

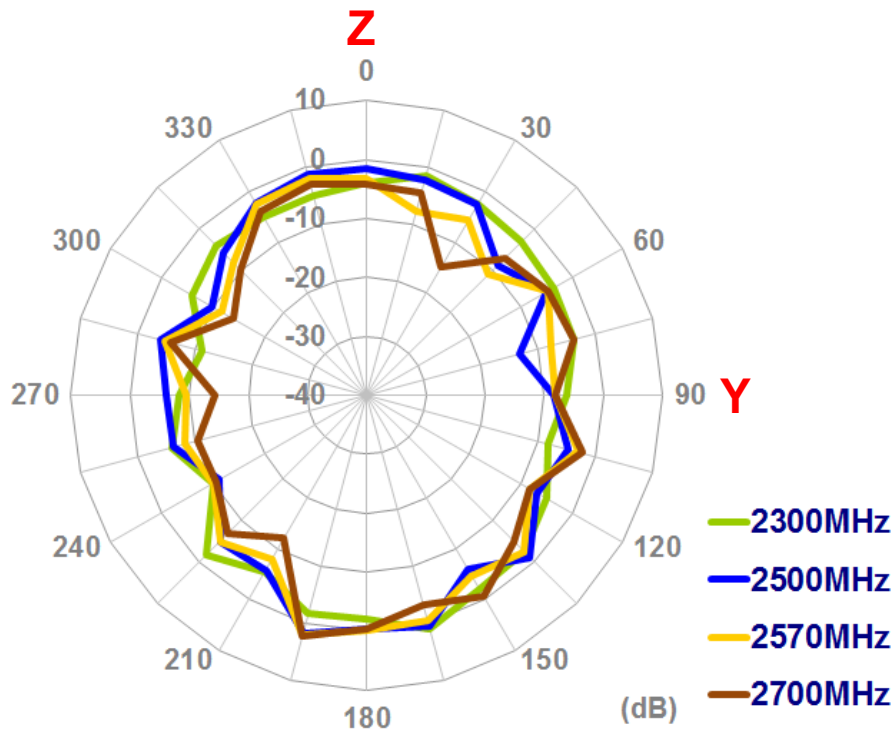

4.8 Antenna Setup – bent At 90 Degrees With 30cmX30cm Ground Plane Center

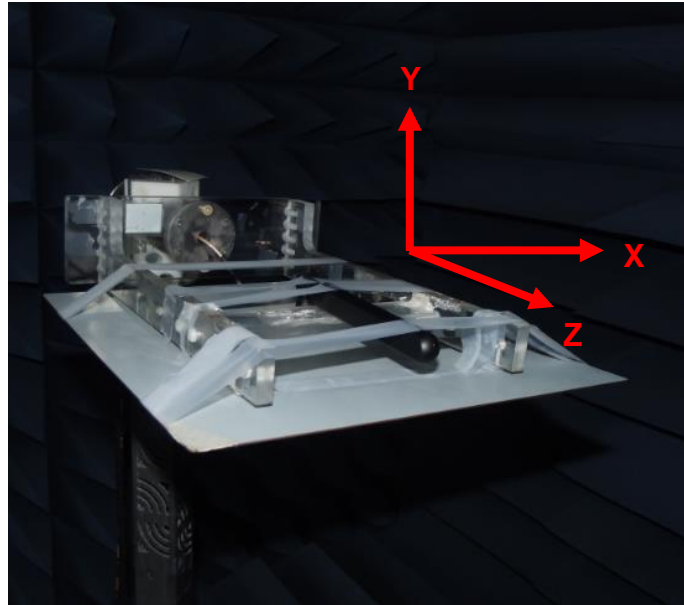

Antenna bent 90 degrees with 30cm x 30cm ground plane center

- **Antenna Radiation Patterns**

X-Y plane

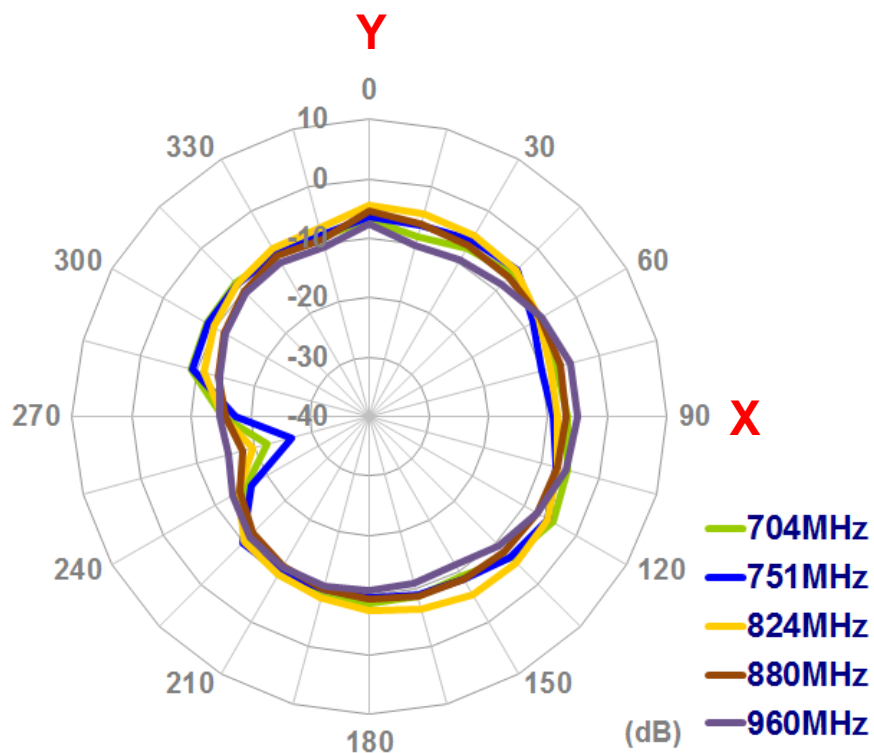

X-Z plane

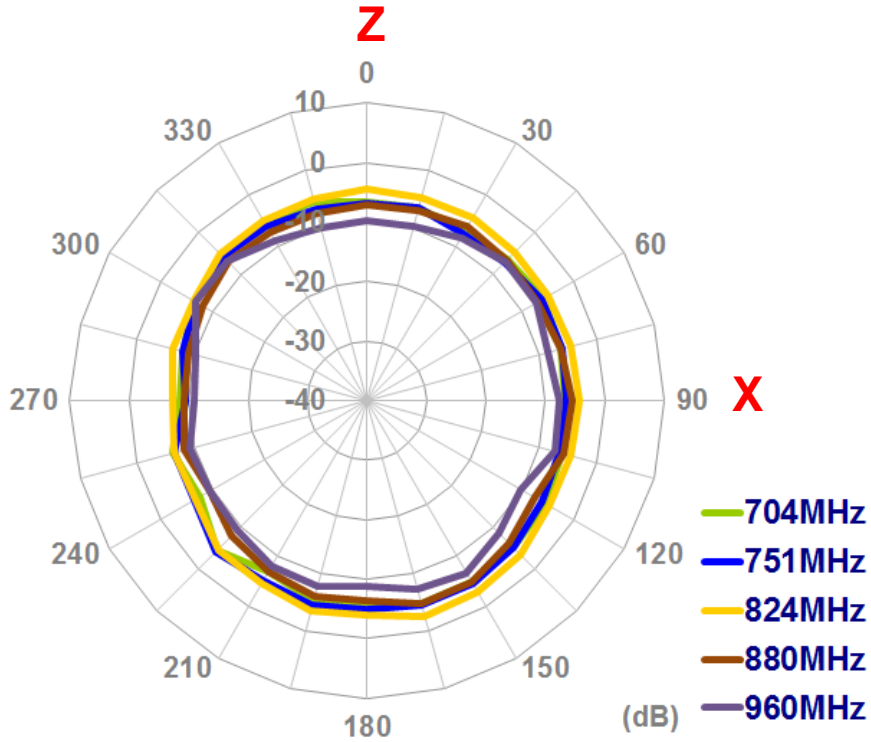

Y-Z plane

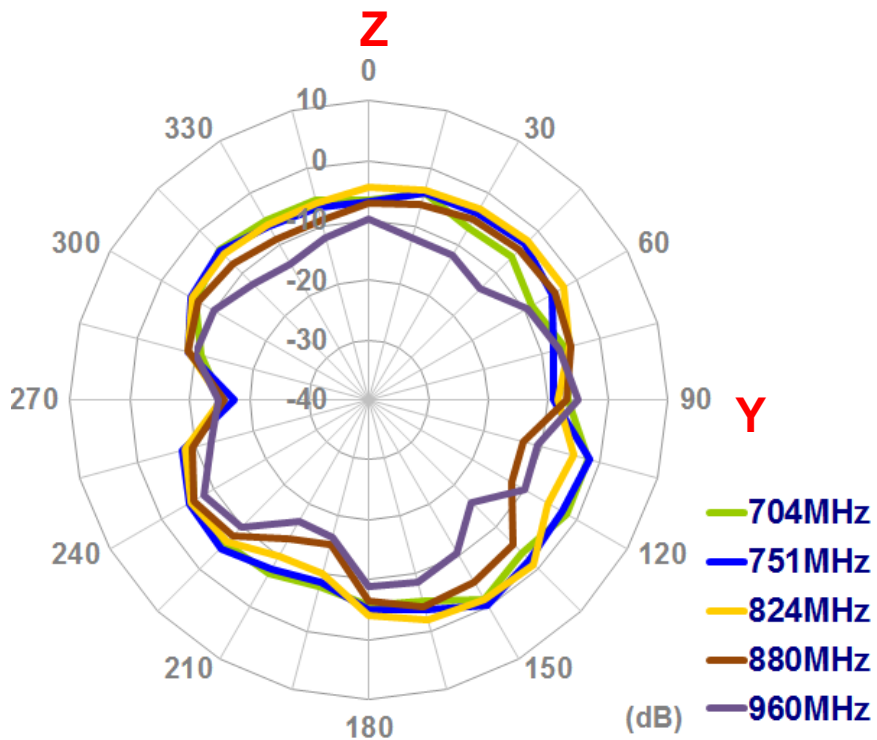

X-Y plane

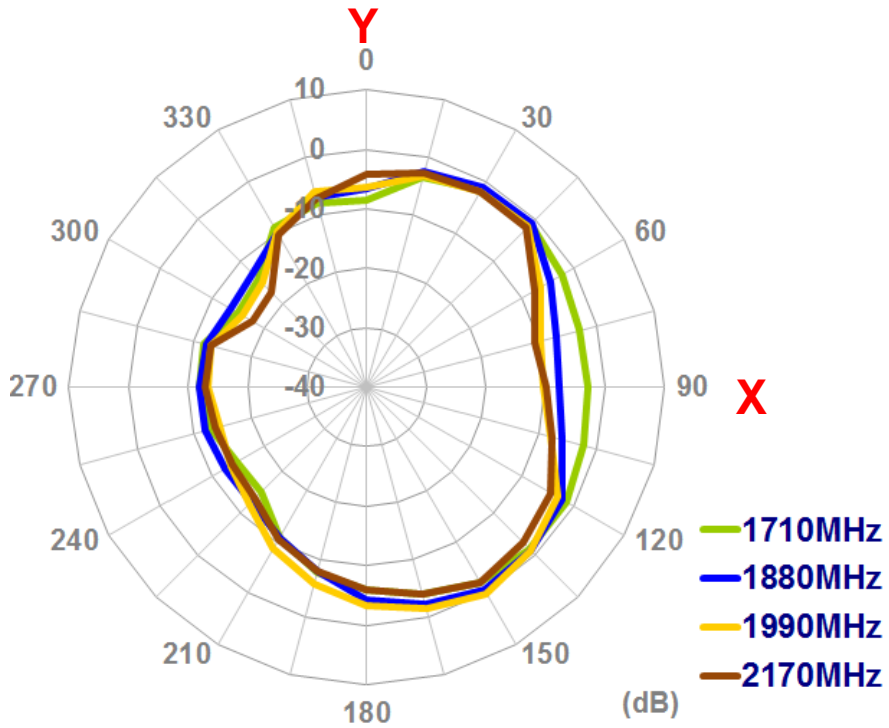

X-Z plane

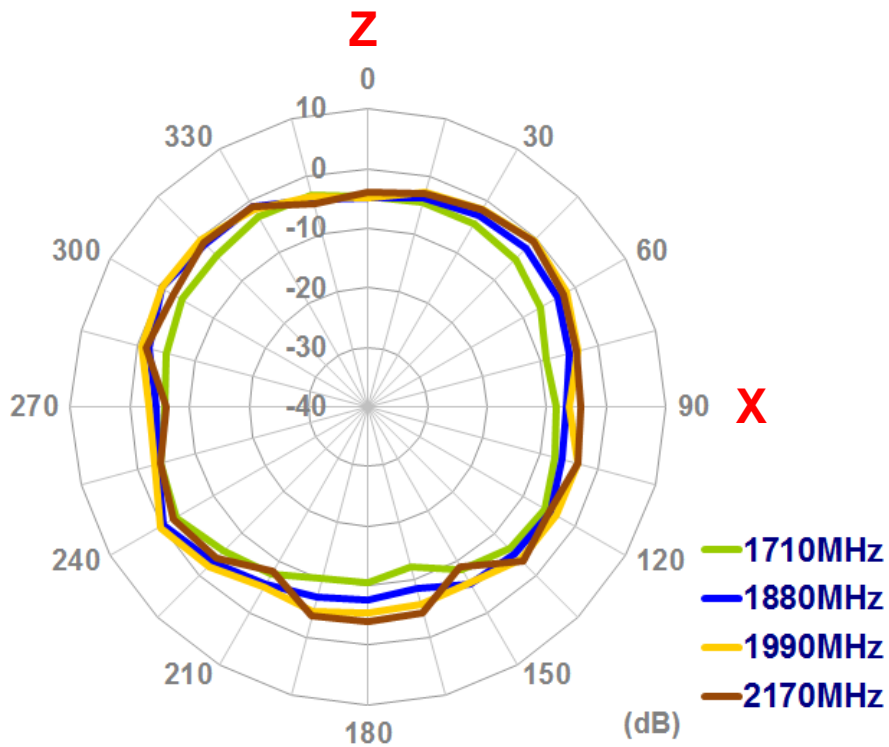

Y-Z plane

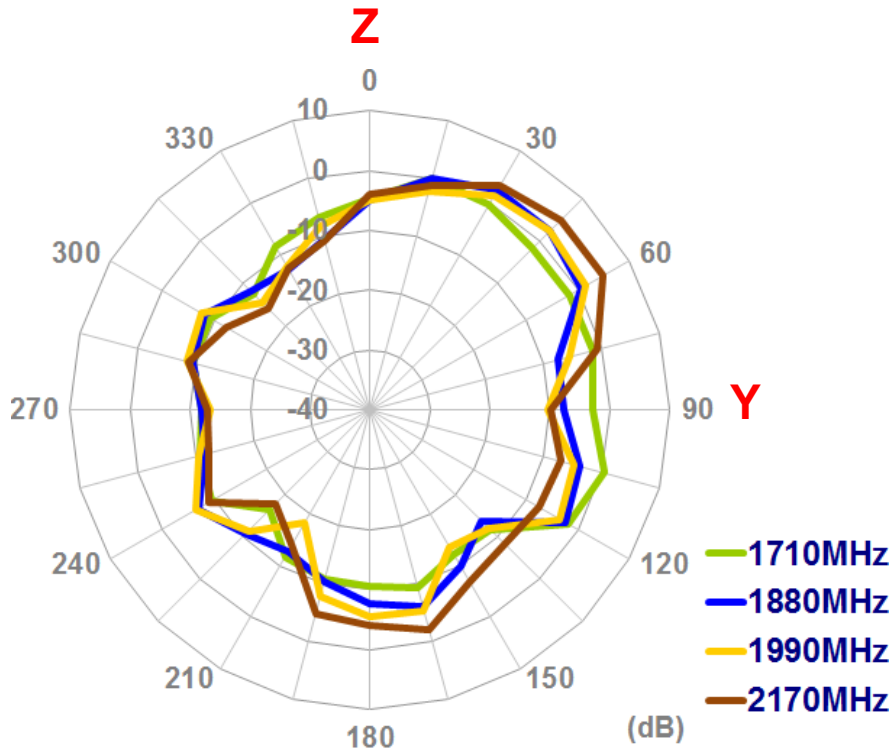

X-Y plane

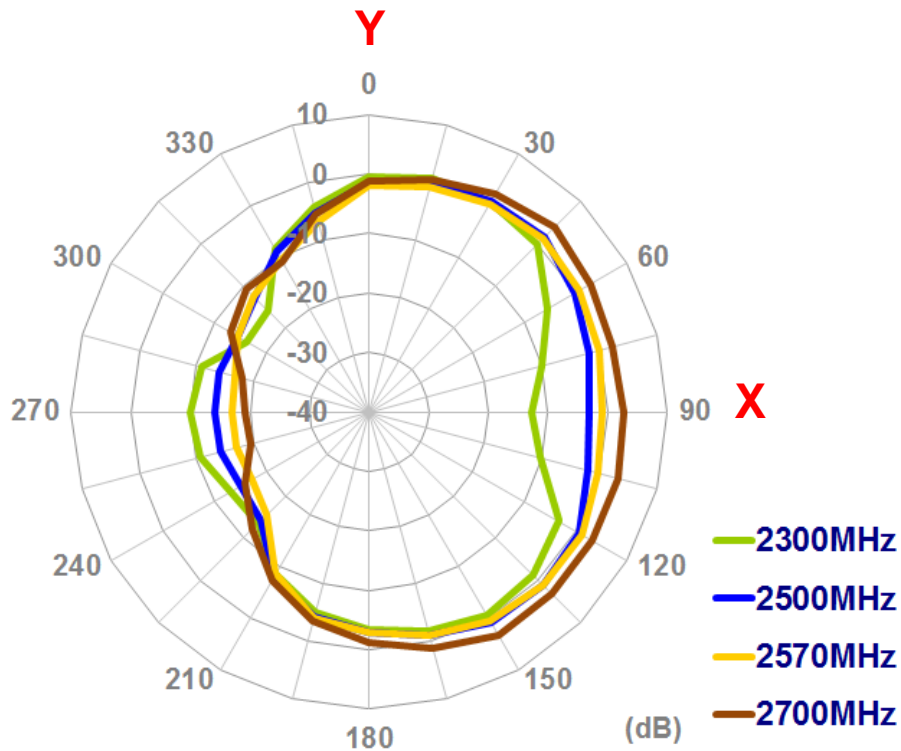

X-Z plane

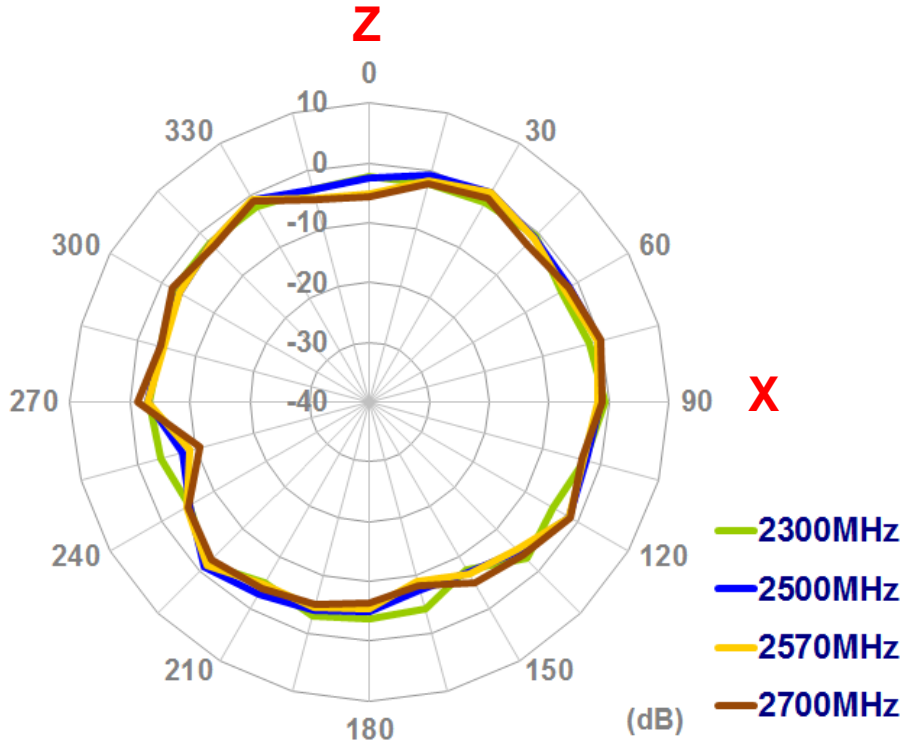

Y-Z plane

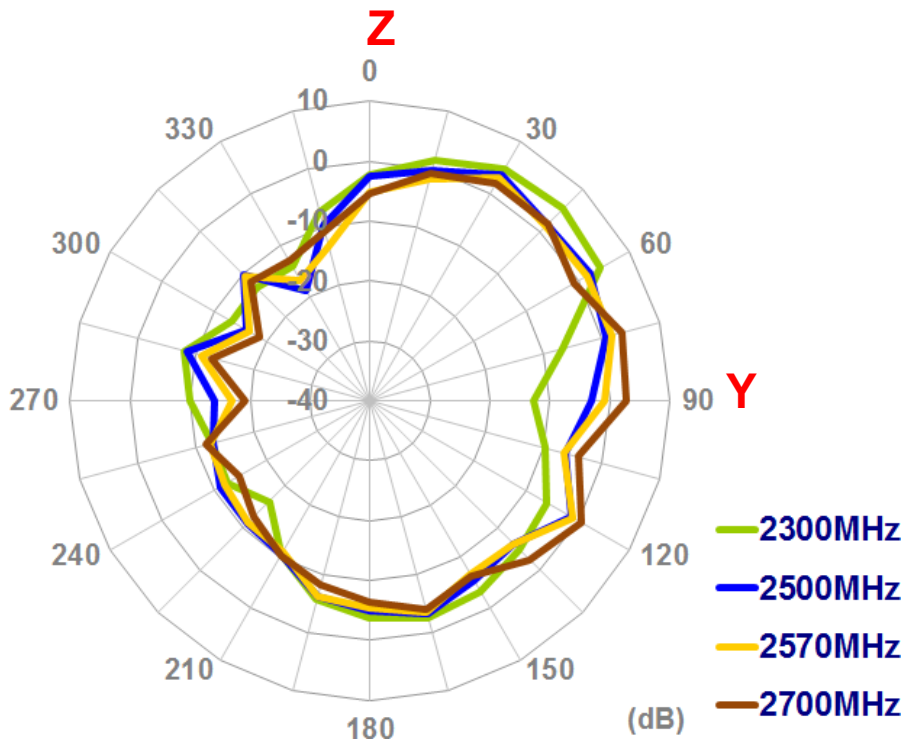

5. Drawing

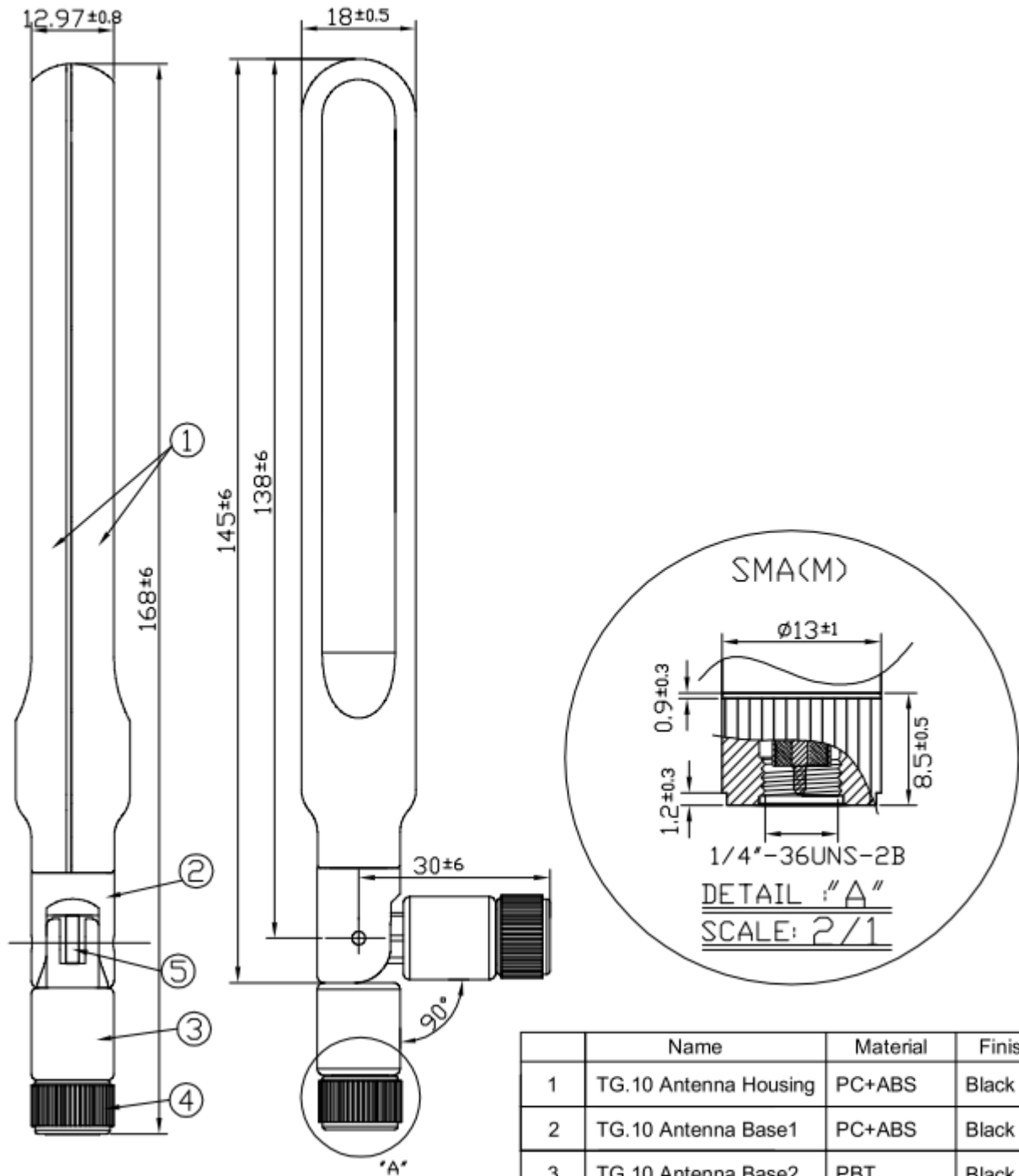

	Name	Material	Finish	QTY
1	TG.10 Antenna Housing	PC+ABS	Black	2
2	TG.10 Antenna Base1	PC+ABS	Black	1
3	TG.10 Antenna Base2	PBT	Black	1
4	SMA(M)	Brass	Black	1
5	RG178 Cable	RG178	Brown	1

6. Packaging

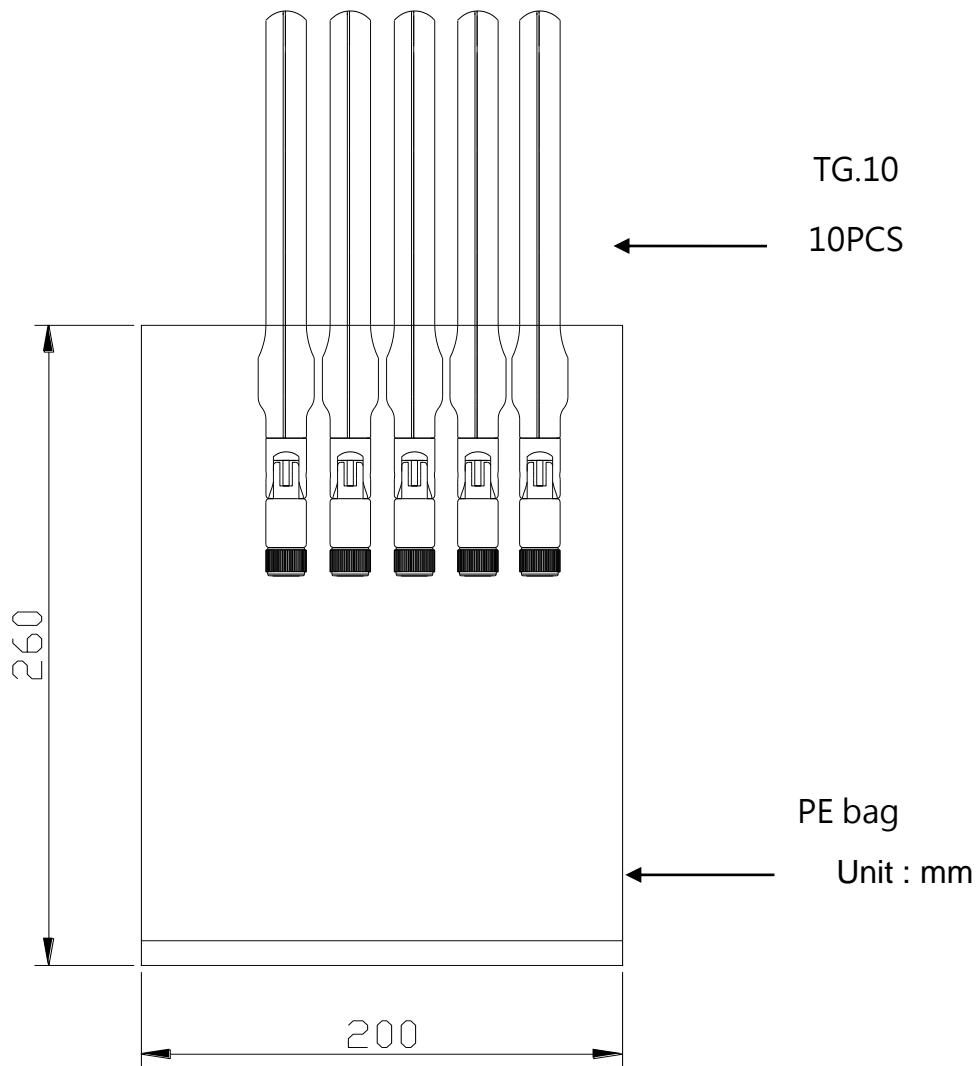

7. Installation

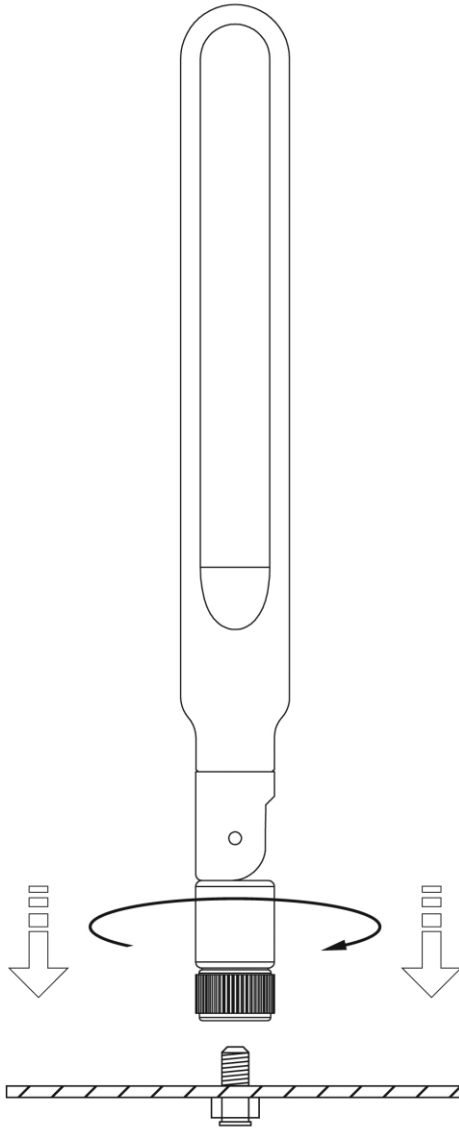

Recommended torque for mounting is 0.9 N·m
Maximum torque for mounting is 1.176 N·m

X-ON Electronics

Largest Supplier of Electrical and Electronic Components

Click to view similar products for [Antennas](#) category:

Click to view products by [B+B SmartWorx](#) manufacturer:

Other Similar products are found below :

[CCT FM1](#) [ABFT](#) [AD-NM-SMAF 001-0021](#) [CTC110](#) [MAF94149](#) [EXE902SF](#) [MMCX-SMA-100](#) [PDQ24496-91NF](#) [GAN30084EU](#) [930-033-R](#) [A08-HABUF-P5I](#) [AAF95035](#) [DG-ANT-20DP-BG-B](#) [APAMPGJ-141](#) [1513563-1](#) [OF86315-FNF](#) [OP24516DS-91NM](#) [A09-HASM-7](#) [EXE902MD](#) [EXE902SM](#) [SPDA17806/2170LAR](#) [APAMPG-117](#) [GPS1575SP26-004](#) [GPS15MGSMA](#) [CMD69273P-30NF](#) [CMQ69273-30NF](#) [RD2458-5-OTDR-NM](#) [RD2458-5-RSMA](#) [TRAB24/49003](#) [W4120ER5000](#) [W6102B0100](#) [YE572113-30RSMM](#) [108-00014-50](#) [SPDA17RP918](#) [OP24516SX-91NM](#) [OP24516SX-91RSMM](#) [CMQ69273P-30NF](#) [CMS69273-30NF](#) [CMS69273P-30NF](#) [TRAB24003N](#) [TRAB24003NP](#) [TRAB8213NP](#) [TRAB8903](#) [A09-Y8NF](#) [A09-Y11NF](#) [A09-HSM-7](#) [A09-F8NF-M](#) [A09-F5NF-M](#)