

Features

The DXM1500-B1 Wireless Controller is an industrial wireless controller that facilitates Industrial Internet of Things (IIoT) applications. As a communications gateway, it interfaces local serial ports, local I/O ports, and local ISM radio devices to the Internet using a cellular connection or wired Ethernet network connection.

- **High-Performance Wireless Communication**—Uses Sure Cross® DX80 Wireless Gateway or MultiHop radio with 900 MHz or 2.4 GHz ISM bands available for long-range communication
- **Flexible and Customizable**—Expanded internal logic controller with action rules and ScriptBasic programming capable of developing simple or complex solutions to process, log, and control data to/from multiple wireless radios and sensors
- **Improved Speed and Memory**—Upgraded internal processor to use 2850 32-bit integer registers, 2000 floating-point registers, and 1050 non-volatile 32-bit integer registers; expanded ScriptBasic programming capability for faster script processing and ability to build more complex solutions with scripts
- **External Communications**—Cellular modem Internet connectivity
- **Industry Compatibility**—Automation protocols include Modbus/TCP, Modbus RTU, and EtherNet/IP™ for communications between PLCs, HMIs, or other local hosts.
- **Customizable Alerts**—Secure email for alarms and alerts using Banner Cloud Data Services



- Data logged to a removable SD card
- Interactive programmable user interface with LCD and LED indicators
- Industry-standard RS-485, Ethernet, and USB communication ports
- Universal inputs, including NPN/PNP discrete, 4–20 mA analog, 0–10 V analog, counter, and temperature via a 10 kOhm thermistor
- Synchronous counters with a 10 ms clock rate
- Courtesy power outputs for powering external devices
- Discrete outputs (NMOS), Analog Outputs, 0–20 mA or 0–10 V DC
- Solar Controller
- For video tutorials on this product, search "DXM Tutorial" at youtube.com/bannerengineering.

Model Key for the DXM1500-B1 Models

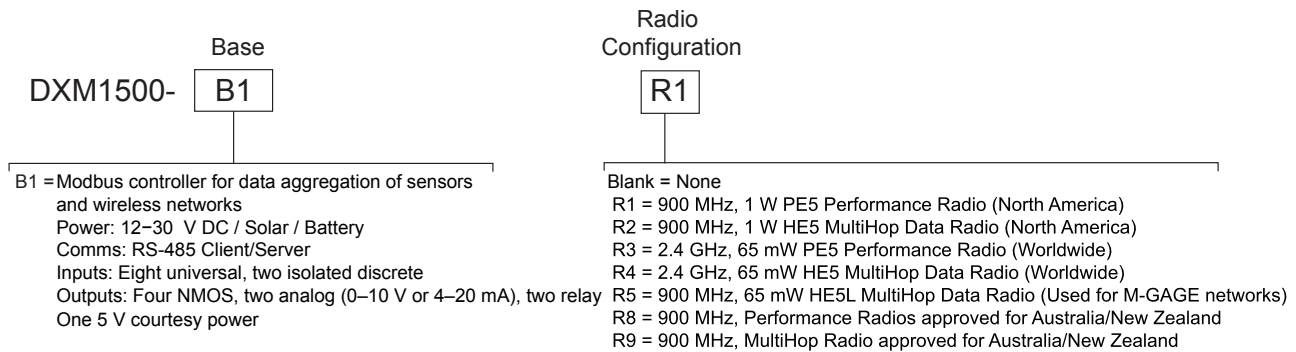

Some example models include, but are not limited to, the following:

Models	Description
DXM1500-B1R1	DXM1500-B1 Wireless Controller with DX80 ISM 900 MHz radio
DXM1500-B1R2	DXM1500-B1 Wireless Controller with DX80 ISM 900 MHz MultiHop radio
DXM1500-B1R3	DXM1500-B1 Wireless Controller with DX80 ISM 2.4 GHz radio
DXM1500-B1R4	DXM1500-B1 Wireless Controller with DX80 ISM 2.4 GHz MultiHop radio

Cellular Communications—Controllers accept Banner LTE-M (CATM1) modems only. Cellular modems are ordered separately as accessories under the following part numbers:

- LTE CAT-M1 AT&T (North America only): **SXI-CATM1ATT-001**
- LTE CAT-M1 Verizon (United States only): **SXI-CATM1VZW-001**
- LTE CAT-M1/NB-IoT Multi-Carrier (Europe only): **SXI-CATM1VWV-001**

For more information, refer to the technical note [Activating a Cellular Modem \(p/n 205026\)](#).



DXM1500 Documentation

- DXM Wireless Controller Sell Sheet, p/n [194063](#)
- DXM1500-B1 Wireless Controller Datasheet, p/n [210854](#)
- DXM1500-B2 Wireless Controller Datasheet, p/n [210855](#)
- DXM150-Bx and 1500-Bx Wireless Controller Instruction Manual, p/n [190038](#)
- DXM ScriptBasic Instruction Manual, p/n [191745](#)
- DXM Controller Configuration Quick Start, p/n [191247](#)
- DXM Configuration Software (p/n [b_4447978](#))
- DXM Configuration Software Instruction Manual, p/n [158447](#)
- DXM EDS [Configuration file](#) for Allen-Bradley PLCs
- EIP Configuration File for DXM 1xx-BxR1 and R3 models (p/n [194730](#))
- Activating a Cellular Modem (p/n [b_4419353](#))
- Video tutorials: Search "DXM Tutorial" at [youtube.com/bannerengineering](https://www.youtube.com/channel/UCBnRnRnRnRnRnRnRnRnRnRn).
- Additional technical notes

For more information about the DXM1500 family of products, including technical notes, configuration examples, and ScriptBasic programs, please visit www.bannerengineering.com.

System Overview for the DXM1500-B1

Banner's DXM Logic Controller integrates Banner's wireless radio, cellular connectivity, and local I/O to provide a platform for the Industrial Internet of Things (IIoT).

Inputs and Outputs	Connectivity	Logic Controller	User Interface
Universal inputs	Cellular	Action rules	LCD screen
Discrete outputs	Sure Cross radios	Programming language	LED indicators
Courtesy power output	Ethernet	Scheduler	
Isolated inputs	USB	Push to the cloud	
Relay outputs	RS-485 client/server	Data logging	
	RS-232		

Modbus registers for internal local registers (Modbus ID 199)

Local Registers	Type	Description
1–845	32-bit integer	Local data registers
846–849	32-bit integer	Reset, Constant, Timer
851–900	32-bit non-volatile integer	Data flash, non-volatile
901–1000		Reserved for internal use
1001–5000	Floating point	Floating point registers, local data registers
5001–7000	32-bit integer	Local data registers
7001–8000	32-bit non-volatile integer	Data flash, non-volatile
> 10000		Read-only virtual registers, system-level data

Inputs and Outputs

On-board universal and programmable I/O ports connect to local sensors, indicators, and control equipment.
 Universal inputs, discrete outputs, courtesy power outputs
 Battery backup, solar controller

Connectivity

The DXM's wired and wireless connectivity options make it easy to share data between local and remote equipment. The cellular modem option eliminates the need for IT infrastructures to connect remote equipment for sensing and control. The integrated Sure Cross® wireless radio enables Modbus connectivity to remote sensors, indicators, and control equipment.
 Wired Connectivity -- Ethernet: Modbus TCP, Ethernet/IP, or Profinet; Field Bus: Modbus RS-485 Client/Server
 Wireless Connectivity -- Sure Cross Wireless Radio: DX80 900 MHz, DX80 2.4 GHz, MultiHop 900 MHz, or MultiHop 2.4 GHz; Cellular modem: LTE-M (United States) or LTE-M/NB-IoT (outside the United States)

Logic Controller—Program the DXM's logic controller using action rules and/or ScriptBasic language, which can execute concurrently. The control functions allow freedom when creating custom sensing and control sequences. The logic controller supports the Modbus protocol standards for data management, ensuring seamless integration with existing automation systems. File and LCD password protection is an option.

Register Mapping

Cyclical Read rules from wireless devices or local wired Modbus devices that include optional scaling, error conditions, and the ability to activate a read rule

Cyclical or Change of State Write rules to wireless devices or local wired Modbus devices with scaling

Modbus/TCP Client Read or Write rules for external devices on the network

Action Rules

Thresholds (IF/THEN/ELSE) with timers, minimum on/off time, and logging options

Math/Logic Rules (arithmetic and bitwise operators)

Control Logic (logical operators and SR/T/D/JK flip flops)

Trending (multiple averaging filters)

Tracking (counts, on/off times)

Push data on conditions

User Interface—A simple user interface consists of an LCD screen and four LED indicators. Use the LCD to access system status and setup, view user-selectable events or data, and to bind and perform site surveys for Sure Cross radios. Configure the user-programmable LEDs to indicate the status of the DXM, processes, or equipment.

User-Programmable LCD

Binding Sure Cross radios

Conducting a Site Survey

Viewing sensor information

Scheduler

Time/calendar-based events

Holiday skips

One-time events

Dynamic scheduler updating

Astronomical clock

Optional Text Programming Language

ScriptBasic to create variables, arrays, functions, loops, IF/THEN/ELSE, logical and arithmetic operators, API commands, register access, string functions and operators, time commands

Data Logging

Cyclic data/event logging

Viewing the system's status

User-Defined LED Indicators

Four multicolor LEDs: green, amber, and red

Programmable behavior

Applications Overview

The DXM1500-B1 Wireless Controller is ideal for smart factory and facilities applications, including:

- Productivity solutions, such as
 - Call for parts, service, or maintenance
 - Pick-to-light
 - Tank level monitoring
- Predictive maintenance and continuous monitoring using
 - Vibration and temperature monitoring
 - Non-contact temperature monitoring
- Environmental monitoring and control, such as temperature and humidity monitoring

The DXM1500-B1 Wireless Controller can provide visual indication using indicator lights, collect data, and interface with automation systems.

Specifications

Radio Specifications

Supplied Antenna

A 2 dB antenna ships with this device. High-gain antennas are available, but the transmit power and range depends on the antenna gain, environment, and line of sight. Always verify your wireless network's range by performing a Site Survey.

Radio Transmit Power (900 MHz, 1 Watt radios)

Conducted: 30 dBm (1 W)

EIRP with the supplied 2 dB antenna: < 36 dBm

Radio Transmit Power (2.4 GHz radios)

Conducted: < 18 dBm (65 mW)

EIRP with the supplied 2 dB antenna: < 20 dBm (100 mW)

Radio Range

900 MHz (in 1 Watt mode): Up to 9.6 km (6 miles) with the supplied 2 dB antenna

2.4 GHz: Up to 3.2 km (2 miles) with the supplied 2 dB antenna

Antenna Minimum Separation Distance

900 MHz (transmitting at 150 mW and 250 mW): 2 m (6 ft) with the supplied 2 dB antenna

900 MHz (transmitting at 1 Watt): 4.57 m (15 ft) with the supplied 2 dB antenna

2.4 GHz: 0.3 m (1 ft) with the supplied 2 dB antenna

Antenna Connection

Ext. Reverse Polarity SMA, 50 Ohms

Max Tightening Torque: 0.45 N·m (4 lbf·in)

Spread Spectrum Technology

FHSS (Frequency Hopping Spread Spectrum)

Link Timeout (Performance)

Gateway: Configurable via User Configuration Software

Node: Defined by Gateway

Radio Packet Size (MultiHop)

900 MHz: 175 bytes (85 Modbus registers)

2.4 GHz: 75 bytes (37 Modbus registers)

900 MHz Compliance (SX7023 Radio Module)

Radio module is indicated by the product label marking

Contains FCC ID: UE3SX7023EXT: FCC Part 15, Subpart C, 15.247

Contains IC: 7044A-SX7023EXT

900 MHz Compliance (RM1809 Radio Module)

Radio module is indicated by the product label marking
 Contains FCC ID: UE3RM1809: FCC Part 15, Subpart C, 15.247
 Contains IC: 7044A-RM1809
 IFT: RCPBARM13-2283



2.4 GHz Compliance (DX80-2400 Radio Module)

Radio module is indicated by the product label marking
 Contains FCC ID: UE300DX80-2400: FCC Part 15, Subpart C, 15.247
 Radio Equipment Directive (RED) 2014/53/EU
 Contains IC: 7044A-DX8024
 ANATEL: 15966-21-04042



2.4 GHz Compliance (SX243 Radio Module)

Radio module is indicated by the product label marking
 Contains FCC ID: UE3SX243: FCC Part 15, Subpart C, 15.247
 Radio Equipment Directive (RED) 2014/53/EU
 ETSI/EN: EN 300 328 V2.2.2 (2019-07) [RED HarmStds]
 Contains IC: 7044A-SX243
 ANATEL: 03737-22-04042



RS-232 Communication Specifications

Communication Hardware (MultiHop RS-232)

Interface: 2-wire RS-232

Baud rates: 9.6k, 19.2k (default), or 38.4k via DIP switches;
 1200 and 2400 via the MultiHop Configuration Software
 Data format: 8 data bits, no parity, 1 stop bit

RS-485 Communication Specifications

Communication Hardware (MultiHop RS-485)

Interface: 2-wire half-duplex RS-485

Baud rates: 9.6k, 19.2k (default), or 38.4k via DIP switches;
 1200 and 2400 via the MultiHop Configuration Software
 Data format: 8 data bits, no parity, 1 stop bit

DXM1500-B1 Power and IO Specifications

Supply Voltage

12 to 30 V DC (use only with a suitable Class 2 power supply (UL) or a SELV (CE) power supply) or
 12 V DC solar panel and 12 V sealed lead acid battery

Selectable (Jumper) Power Out

Output on pin 45, jumper selects 2.7 V or battery
 Output on pin 35, jumper selects 4.2 V or incoming power
 100 mA maximum

Solar Power

12 V sealed lead acid battery
 2 A maximum charge current
 12 V, 20 W maximum solar panel

Solar Power Battery Charging

1 A maximum with 20 Watt solar panel

Power Consumption

35 mA average at 12 Volts (exclusive of load)

Indicators

Four LEDs, four control buttons, one LCD

Security Protocols

VPN, SSL, and HTTPS

Communication Protocols

Modbus RTU Client/Server, Modbus TCP, and Ethernet/IP

Logging

8 GB maximum; removable Micro SD card format

Construction

Polycarbonate; DIN rail mount option

Discrete Inputs

Optically isolated AC input type
 Input to output isolation: 2.5 kV

Counters, Synchronous

32-bits unsigned
 10 ms clock rate minimum

Universal Inputs

Sinking/Sourcing discrete, 4–20 mA analog, 0–10 V analog, counter, and temperature 10 kOhm thermistor

Relay Outputs

SPDT (Form C) relay
 250 V ac, 16 A

Analog Outputs (DAC)

0 to 20 mA or 0 to 10 V DC output
 Accuracy: 0.1% of full scale +0.01% per °C
 Resolution: 12-bit

Discrete Output Rating (NMOS)

Less than 1 A max current at 30 V DC
 ON-State Saturation: Less than 0.7 V at 20 mA
 ON Condition: Less than 0.7 V
 OFF Condition: Open

Environmental Specifications (DXM150x with Relay)

Operating Conditions

–20 °C to +60 °C (–4 °F to +140 °F)

95% maximum relative humidity (non-condensing)

Operating the devices at the maximum operating conditions for extended periods can shorten the life of the device.
 Radiated Immunity: 10 V/m (EN 61000-4-3)

Environmental Rating
 IP20

Certifications



Banner Engineering BV
 Park Lane, Culliganlaan 2F bus 3
 1831 Diegem, BELGIUM

Shock and Vibration

All models meet IEC 60068-2-6 and IEC 60068-2-27 testing criteria
 Shock: 15G 11 ms duration, half sine wave per IEC 60068-2-27
 Vibration: 10 Hz to 55 Hz, 0.5 mm peak-to-peak amplitude per IEC 60068-2-6



Turck Banner LTD Blenheim House
 Blenheim Court
 Wickford, Essex SS11 8YT
 GREAT BRITAIN

(CE/UKCA approval only applies to 2.4 GHz models)

DXM150 and DXM1500 Dimensions

All measurements are listed in millimeters [inches], unless noted otherwise.

Dimensions for the DXM150 and DXM1500 models

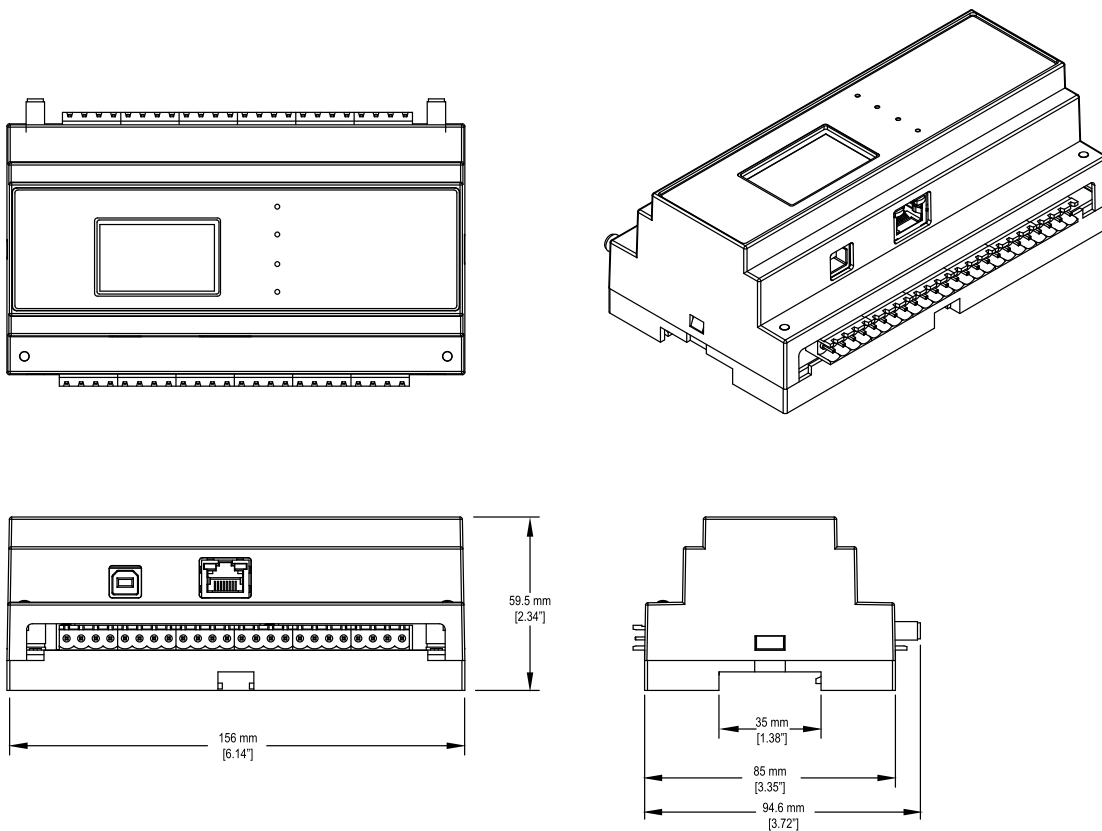

DXM Accessories

For a complete list of all the accessories for the Sure Cross wireless product line, please download the Accessories List (p/n [b_3147091](#)).

<p>Cordsets MQDC1-506—5-pin M12, straight, single-ended, 6 ft MQDC1-530—5-pin M12, straight, single-ended, 30 ft MQDC1-506RA—5-pin M12, right-angle, single-ended, 6 ft MQDC1-530RA—5-pin M12, right-angle, single-ended, 30 ft</p>	<p>Misc Accessories BWA-CG-5-3X5,6-10—Cable Gland Pack: 1/2-inch NPT, Cordgrip for 3 holes of 2.8 to 5.6 mm diam, 10 pack BWA-HW-052—Cable Gland and Vent Plug Pack: includes 1/2-inch NPT gland, 1/2-inch NPT multi-cable gland, and 1/2-inch NPT vent plug, one each</p>
<p>Static and Surge Suppressor BWC-PRC827-DC—Surge Suppressor, bulkhead, DC Blocking, N-Type Female, N-Type Male</p>	<p>Antenna Cables BWC-1MRSMN05—LMR200 RP-SMA to N-Type Male, 0.5 m BWC-2MRSFRS6—LMR200, RP-SMA Male to RP-SMA Female Bulkhead, 6 m BWC-4MNFN6—LMR400 N-Type Male to N-Type Female, 6 m</p>

Continued on page 6

Continued from page 5

<p>Short-Range Omni Antennas BWA-2O2-D—Antenna, Dome, 2.4 GHz, 2 dBi, RP-SMA Box Mount BWA-9O2-D—Antenna, Dome, 900 MHz, 2 dBi, RP-SMA Box Mount BWA-9O2-RA—Antenna, Rubber Fixed Right Angle, 900 MHz, 2 dBi, RP-SMA Male Connector</p> <p>Medium-Range Omni Antennas BWA-9O5-C—Antenna, Rubber Swivel, 900 MHz 5 dBi, RP-SMA Male Connector BWA-2O5-C—Antenna, Rubber Swivel, 2.4 GHz 5 dBi, RP-SMA Male Connector</p>	<p>Long-Range Omni Antennas BWA-9O8-AS—Antenna, Fiberglass, 3/4 Wave, 900 MHz, 8 dBi, N-Type Female Connector BWA-2O8-A—Antenna, Fiberglass, 2.4 GHz, 8 dBi, N-Type Female Connector</p> <p>Long-Range Yagi Antennas BWA-9Y10-A—Antenna, 900 MHz, 10 dBd, N-Type Female Connector</p> <p>Cellular Antenna BWA-CELLA-002—Cellular multiband, 2 dBi, RP-SMA male connection, 6.3 inch blade style. Datasheet: b_4475176</p>
<p>Enclosures and DIN Rail Kits BWA-AH864—Enclosure, Polycarbonate, with Opaque Cover, 8 × 6 × 4 BWA-AH1084—Enclosure, Polycarbonate, with Opaque Cover, 10 × 8 × 4 BWA-AH12106—Enclosure, Polycarbonate, with Opaque Cover, 12 × 10 × 6 BWA-AH8DR—DIN Rail Kit, 8", 2 trilobular/self-threading screws BWA-AH10DR—DIN Rail Kit, 10", 2 trilobular/self-threading screws BWA-AH12DR—DIN Rail Kit, 12", 2 trilobular/self-threading screws</p>	<p>Power Supplies PSD-24-4—DC Power Supply, Desktop style, 3.9 A, 24 V DC, Class 2, 4-pin M12 quick disconnect (QD) PSDINP-24-13 —DC power supply, 1.3 Amps, 24 V DC, with DIN Rail Mount, Class I Division 2 (Groups A, B, C, D) Rated PSDINP-24-25 — DC power supply, 2.5 Amps, 24 V DC, with DIN Rail Mount, Class I Division 2 (Groups A, B, C, D) Rated BWA-SOLAR PANEL 20W—Solar Panel, 12 V, 20 W, Multicrystalline, 573 × 357 × 30, "L" style mounting bracket included (does not include controller)</p>

Warnings

WARNING:



- **Do not use this device for personnel protection**
- Using this device for personnel protection could result in serious injury or death.
- This device does not include the self-checking redundant circuitry necessary to allow its use in personnel safety applications. A device failure or malfunction can cause either an energized (on) or de-energized (off) output condition.

IMPORTANT: Please download the complete DXM1500-B1 Wireless Controller technical documentation, available in multiple languages, from www.bannerengineering.com for details on the proper use, applications, Warnings, and installation instructions of this device.

IMPORTANT: Por favor descargue desde www.bannerengineering.com toda la documentación técnica de los DXM1500-B1 Wireless Controller, disponibles en múltiples idiomas, para detalles del uso adecuado, aplicaciones, advertencias, y las instrucciones de instalación de estos dispositivos.

IMPORTANT: Veuillez télécharger la documentation technique complète des DXM1500-B1 Wireless Controller sur notre site www.bannerengineering.com pour les détails sur leur utilisation correcte, les applications, les notes de sécurité et les instructions de montage.

Install and properly ground a qualified surge suppressor when installing a remote antenna system. Remote antenna configurations installed without surge suppressors invalidate the manufacturer's warranty. Keep the ground wire as short as possible and make all ground connections to a single-point ground system to ensure no ground loops are created. No surge suppressor can absorb all lightning strikes; do not touch the Sure Cross® device or any equipment connected to the Sure Cross® device during a thunderstorm.

Exporting Sure Cross® Radios. It is our intent to fully comply with all national and regional regulations regarding radio frequency emissions. **Customers who want to re-export this product to a country other than that to which it was sold must ensure the device is approved in the destination country.** The Sure Cross wireless products were certified for use in these countries using the antenna that ships with the product. When using other antennas, verify you are not exceeding the transmit power levels allowed by local governing agencies. This device has been designed to operate with the antennas listed on Banner Engineering's website and having a maximum gain of 9 dBm. Antennas not included in this list or having a gain greater than 9 dBm are strictly prohibited for use with this device. The required antenna impedance is 50 ohms. To reduce potential radio interference to other users, the antenna type and its gain should be so chosen such that the equivalent isotropically radiated power (EIRP) is not more than that permitted for successful communication. Consult with Banner Engineering Corp. if the destination country is not on this list.

IMPORTANT:

- **Never operate a 1 Watt radio without connecting an antenna**
- Operating 1 Watt radios without an antenna connected will damage the radio circuitry.
- To avoid damaging the radio circuitry, never apply power to a Sure Cross® Performance or Sure Cross Multi-Hop (1 Watt) radio without an antenna connected.

IMPORTANT:

- **Electrostatic discharge (ESD) sensitive device**
- ESD can damage the device. Damage from inappropriate handling is not covered by warranty.
- Use proper handling procedures to prevent ESD damage. Proper handling procedures include leaving devices in their anti-static packaging until ready for use; wearing anti-static wrist straps; and assembling units on a grounded, static-dissipative surface.

Banner Engineering Corp Limited Warranty

Banner Engineering Corp. warrants its products to be free from defects in material and workmanship for one year following the date of shipment. Banner Engineering Corp. will repair or replace, free of charge, any product of its manufacture which, at the time it is returned to the factory, is found to have been defective during the warranty period. This warranty does not cover damage or liability for misuse, abuse, or the improper application or installation of the Banner product.

THIS LIMITED WARRANTY IS EXCLUSIVE AND IN LIEU OF ALL OTHER WARRANTIES WHETHER EXPRESS OR IMPLIED (INCLUDING, WITHOUT LIMITATION, ANY WARRANTY OF MERCHANTABILITY OR FITNESS FOR A PARTICULAR PURPOSE), AND WHETHER ARISING UNDER COURSE OF PERFORMANCE, COURSE OF DEALING OR TRADE USAGE.

This Warranty is exclusive and limited to repair or, at the discretion of Banner Engineering Corp., replacement. **IN NO EVENT SHALL BANNER ENGINEERING CORP. BE LIABLE TO BUYER OR ANY OTHER PERSON OR ENTITY FOR ANY EXTRA COSTS, EXPENSES, LOSSES, LOSS OF PROFITS, OR ANY INCIDENTAL, CONSEQUENTIAL OR SPECIAL DAMAGES RESULTING FROM ANY PRODUCT DEFECT OR FROM THE USE OR INABILITY TO USE THE PRODUCT, WHETHER ARISING IN CONTRACT OR WARRANTY, STATUTE, TORT, STRICT LIABILITY, NEGLIGENCE, OR OTHERWISE.**

Banner Engineering Corp. reserves the right to change, modify or improve the design of the product without assuming any obligations or liabilities relating to any product previously manufactured by Banner Engineering Corp. Any misuse, abuse, or improper application or installation of this product or use of the product for personal protection applications when the product is identified as not intended for such purposes will void the product warranty. Any modifications to this product without prior express approval by Banner Engineering Corp will void the product warranties. All specifications published in this document are subject to change; Banner reserves the right to modify product specifications or update documentation at any time. Specifications and product information in English supersede that which is provided in any other language. For the most recent version of any documentation, refer to: www.bannerengineering.com.

For patent information, see www.bannerengineering.com/patents.

FCC Part 15 Class A for Intentional Radiators

This equipment has been tested and found to comply with the limits for a Class A digital device, pursuant to part 15 of the FCC Rules. These limits are designed to provide reasonable protection against harmful interference when the equipment is operated in a commercial environment. This equipment generates, uses, and can radiate radio frequency energy and, if not installed and used in accordance with the instruction manual, may cause harmful interference to radio communications. Operation of this equipment in a residential area is likely to cause harmful interference in which case the user will be required to correct the interference at his own expense.

Industry Canada Statement for Intentional Radiators

This device contains licence-exempt transmitters(s)/receiver(s) that comply with Innovation, Science and Economic Development Canada's licence-exempt RSS(s). Operation is subject to the following two conditions:

1. This device may not cause interference.
2. This device must accept any interference, including interference that may cause undesired operation of the device.

Cet appareil contient des émetteurs/récepteurs exemptés de licence conformes à la norme Innovation, Sciences, et Développement économique Canada. L'exploitation est autorisée aux deux conditions suivantes:

1. L'appareil ne doit pas produire de brouillage.
2. L'utilisateur de l'appareil doit accepter tout brouillage radioélectrique subi, même si le brouillage est susceptible d'en compromettre le fonctionnement.

Notas Adicionales (con Antena)

Información México: La operación de este equipo está sujeta a las siguientes dos condiciones: 1) es posible que este equipo o dispositivo no cause interferencia perjudicial y 2) este equipo debe aceptar cualquier interferencia, incluyendo la que pueda causar su operación no deseada.

Banner es una marca registrada de Banner Engineering Corp. y podrán ser utilizadas de manera indistinta para referirse al fabricante. "Este equipo ha sido diseñado para operar con las antenas tipo Omnidireccional para una ganancia máxima de antena de 6 dBd y Yagi para una ganancia máxima de antena 10 dBd que en seguida se enlistan. También se incluyen aquellas con aprobación ATEX tipo Omnidireccional siempre que no excedan una ganancia máxima de antena de 6dBd. El uso con este equipo de antenas no incluidas en esta lista o que tengan una ganancia mayor que 6 dBd en tipo omnidireccional y 10 dBd en tipo Yagi, quedan prohibidas. La impedancia requerida de la antena es de 50 ohms."

Approved Antennas

BWA-902-C--Antena, Omni 902-928 MHz, 2 dBd, junta de caucho, RP-SMA Macho

BWA-905-C--Antena, Omni 902-928 MHz, 5 dBd, junta de caucho, RP-SMA Macho
BWA-906-A--Antena, Omni 902-928 MHz, 6 dBd, fibra de vidrio, 1800mm, N Hembra
BWA-9Y10-A--Antena, Yagi, 900 MHz, 10 dBd, N Hembra

Mexican Importer

Banner Engineering de México, S. de R.L. de C.V. | David Alfaro Siqueiros 103 Piso 2 Valle oriente | San Pedro Garza Garcia Nuevo León,
C. P. 66269

81 8363.2714

Document title: DXM1500-B1 Wireless Controller Datasheet
Part number: 210854
Revision: G
© Banner Engineering Corp. All rights reserved.



X-ON Electronics

Largest Supplier of Electrical and Electronic Components

Click to view similar products for [Logic Controllers](#) category:

Click to view products by [Banner](#) manufacturer:

Other Similar products are found below :

[G4ODC5R](#) [TM221CE40R](#) [TM221C40R](#) [TM221CE40T](#) [TM221CE24R](#) [88970224](#) [88970152](#) [88982113](#) [SNAP-OMR6-C](#) [DXM1200-B1R1](#)
[DXM1200E-B1R3](#) [DXM1200E-B1R1](#) [DXM1500-B1R1](#) [88970021](#) [88970041](#) [88970045](#) [88970051](#) [88970055](#) [88970052](#) [88970142](#)
[88970161](#) [88970165](#) [88970162](#) [88970211](#) [88970221](#) [88970231](#) [88970233](#) [88970270](#) [88970042](#) [88974021](#) [88974023](#) [88974024](#) [88974031](#)
[88974041](#) [88974043](#) [88974042](#) [88974044](#) [88974051](#) [88974054](#) [88974052](#) [88974161](#) [88974163](#) [88974162](#) [88974164](#) [88983901](#) [88983902](#)
[G4ODC5R5](#) [GRV-R7-MM1001-10](#) [GRV-R7-MM2001-10](#) [TM221C24R](#)