

# 承 認 書

## SPECIFICATION FOR APPROVAL

<i>CUSTOMER:</i>	
<i>CUSTOMER P/N</i>	
<i>PART NO:</i>	
<i>DESCRIPTION:</i>	<i>SMD POWER INDUCTORS</i>
<i>PRODUCTS NO:</i>	BCNR3010C-2R2M
<i>PRODUCTS REV:</i>	01
<i>DATE:</i>	2018-6-7

<i>PURCHASER CONFIRMED.</i>		
<i>APPROVAL BY</i>	<i>CHECK BY</i>	<i>DRAWN BY</i>
<i>REMARK</i>		

<i>PROVIDER ENGINEER DEPT.</i>		
<i>APPROVAL BY</i>	<i>CHECK BY</i>	
		Chenlinli

### 誠陽實業有限公司

TAIWAN CHENG YANG COMPONENT CORP

2F-1, NO. 176, Chine-Yi Road., Zhonghe District, New Taipei City, TAIWAN(R.O.C)

新北市中和區建一路 176 號 2 樓之一

POSTAL CODE: 23500

TEL NO.:+886-2- 8228-0930 FAX NO.:+886-2-8228-0929 E-mail:h21803@ms29.hinet.net

### 寶誠電子有限公司

ZHUHAI BAO CHENG ELECTRONICSCO.,LTD

Guan Tang Industrial Park, Tang Jia Wan Town, Zhuhai City, Guangdong Province, CHINA

中國廣東省珠海市塘家灣鎮官塘工業區

POSTAL CODE: 519085

TEL NO:86-756-3383187 FAX NO:86-756-3380704 E-mail: [baocheng@baocheng.biz](mailto:baocheng@baocheng.biz)

### 昆山誠陽電子有限公司

KUNSHAN CHENG YANG ELECTRONICSCO.,LTDP

Qiang-An Road., High-Tech. Industrial Park, Kunshan City, Jiangsu Province, China

江蘇省昆山市高科技工業園區強安路 35 號

POSTAL CODE: 215300

TEL NO:86-512-57823500 FAX NO:86-512-57823503 E-mail: [kscy@taiwan-chengyang.com.tw](mailto:kscy@taiwan-chengyang.com.tw)



TAIPEI OFFICE



CHINA FACTORY

# [SPECIFICATION]

## [POWER INDUCTOR] (BCNR3010C-2R2M)

- \* All the materials used in this product are registered material under the Law Concerning the Examination and Regulation of Manufacture, etc. of Chemical Substances.
- \* This product has not been manufactured with any ozone-depleting chemical controlled under the Montreal Protocol.
- \* All the materials used in this product contain no brominated materials of PBBOs or PBBs as the flame-retardant.
- \* "The Term of Validity" of Product Specifications for Information Unless otherwise requested (including from customer), the term of validity shall be renewed automatically.  
Then, information and specifications shall be not issued.

### 1. SCOPE

This specification covers the Power Inductor to be delivered to.

### 2. PART NUMBER OF PRODUCTS

This part number of the products in this specification shall be SNR3010F-2R2M-T -PFs.

### 3. TEST CONDITIONS

The ambient temperature shall be 5°C to 35°C and the relative humidity 35% to 85%, unless otherwise specified.  
When the test result is doubtful, the sample in question shall be tested again at 20±2 °C, 65±5%RH.

### 4. APPEARANCE DIMENSIONS AND CONSTRUCTION

Inductors shall be free from distortion, damage, contaminants, whisker and shall be within dimensions specified.

### 5. ELECTRICAL CHARACTERISTICS

As specified in the electrical characteristics table.

### 6. RELIABILITY CHARACTERISTICS

As specified in the reliability characteristics table.

### 7. PACKAGE

The products shall be packed so as not allow absorption damage.

### 8. OPERATING TEMPERATURE

-40°C~+125°C

### 9. OTHERS

The customer is requested to store the products at the normal temperature (-5~35°C) and the normal humidity (85%RH max.) in the packages we supplied.

The package shall not be exposed to direct sunlight and harmful gas and care should be taken so as not to cause dew.

No.	Date	Revision	Check		
			<b>APPROVED</b>	<b>CHECKED</b>	<b>DRAWN</b>

# [SPECIFICATION]

[POWER INDUCTOR] (BCNR3010C-2R2M)

## ■ Apperance Dimentions and Construction

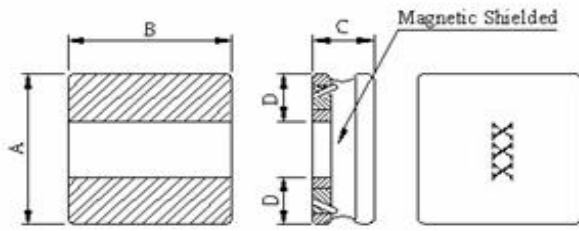

A =	3.0±0.2 m/m
B =	3.0±0.2 m/m
C =	1.0 m/m Max
D =	1.0 m/m ref

## • Schematic Diagram • Connection(Bottom View)

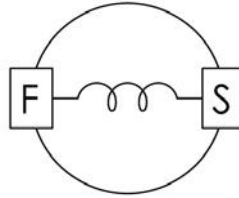
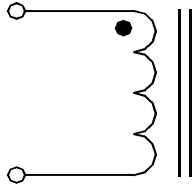

**RoHS**

**Halogen Free**

## ■ Part Number

S	N	R	30	10	F	2R2	M	T	-PF
(1)	(2)	(2)	(3)	(4)	(5)	(6)	(7)	(8)	(19)

(1) Product Code : Power Inductor

(2) Series Type : QH

(3) Size Code : Demension : 3.0 ± 0.2 m/m × 3.0 ± 0.2 m/m

(4) Hight : 10= 1.00 m/m Max

(5) Material Code : C: Ceramic F: Fritte N:Iron

(6) Inductance Code : United is uH and 3 digits are used

860nH=R86 2.2uH=2R2

47uH=470 220uH=221

(7) Tolerance Code : K: ±10% M: ±20% N: ±30%

(8) Outer Coating Resin : Epoxy resin with ferrite powder

(9) PF:pb-FREE

APPROVED

CHECKED

DRAWN

[SPECIFICATION]

[POWER INDUCTOR] (BCNR3010C-2R2M )

Part No.	Inductance ( $\mu$ H )	Test Condition	DCR(m $\Omega$ ) $\pm$ 30%	Rated DC current(A) Max	Heat Rating Current (A) Max	Marking
SNR3010F-2R2M-T-PF	2.2 $\pm$ 20%	100kHz,1V	87	0.96	2.00	2R2

■ Note

- (1) All test date is returned to 25°C ambient.
- (2) Operating temperature range : -40°C to +125°C .
- (3) Isat : DC Current (A) that will cause Lo to drop approximately 30%
- (4) Irms : DC Current (A) that will cause an approximate  $\Delta$ T of 40°C .

■ Test Equipment

- (1) Inductance : LCR test meter : HP4284A
- (2) DCR test meter : DU5010
- (3) Rate current : LCR test meter : Chroma 16502, or equivalent

APPROVED	CHECKED	DRAWN	

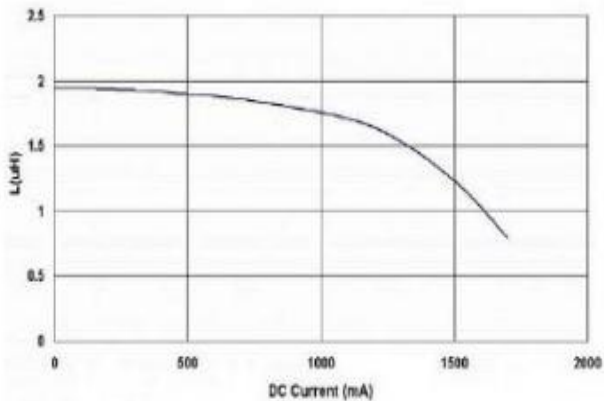

BCNR3010C-2R2M

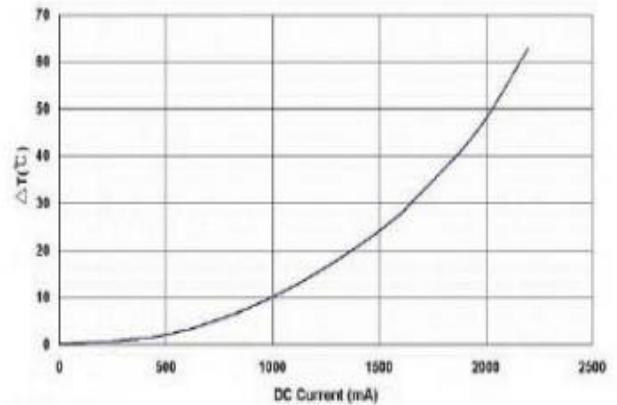

BCNR3010C-2R2M

# [SPECIFICATION]

[POWER INDUCTOR] (BCNR3010C-2R2M)

ITEM	SPECIFICATION	TEST METHOD/CONDITION
DIELECTRIC STRENGTH	Without damage	100V DC shall be applied for 60s between the terminal and the core
INSULATION RESISTANCE	100MΩ or more	100V DC shall be applied between the terminal and the core
TEMPERATURE CHARACTERISTICS	Must be satisfy electrical characteristics	-40~+85°C Standard: Values at 20°C
HUMIDITY CHARACTERISTICS	*There shall not be case deformation or change in appearance.  *Variation of inductance shall within ±3%.  *Must be satisfy electrical characteristics	Inductors shall be stored to 90~95%RH at 60±2°C for 500±8 hours. Measurements shall be made after 1 hour stabilization at room temperature.
HEAT RESISTANCE		Inductors shall be stored to 85±2°C for 500±8 hours. Measurements shall be made after 1 hour stabilization at room temperature.
THERMAL SHOCK		Inductors shall be stored 100 times to the following temperature cycle. 1. -40°C, 30 minutes 2. +85°C, 30 minutes Measurements shall be made after 1 hour stabilization at room temperature.
LOW TEMPERATURE STORAGE		Inductors shall be stored to -40±2°C for 500±8 hours. Measurements shall be made after 1 hour stabilization at room temperature.
HIGH TEMPERATURE LOAD LIFE		With rated current applied. Inductors shall be stored at 85±2°C for 500±8 hours. Measurements shall be made after 1 hour stabilization at room temperature.
HUMIDITY LOAD LIFE	*Variation of inductance shall within ±3%.  *Must be satisfy electrical characteristics	With rated current applied. Inductors shall be subjected to 90~95%RH at 60±2°C for 500±8 hours. Measurements shall be made after 1 hour stabilization at room temperature.

APPROVED    CHECKED    DRAWN

# [SPECIFICATION]

[POWER INDUCTOR] ( BCNR3010C-2R2M )

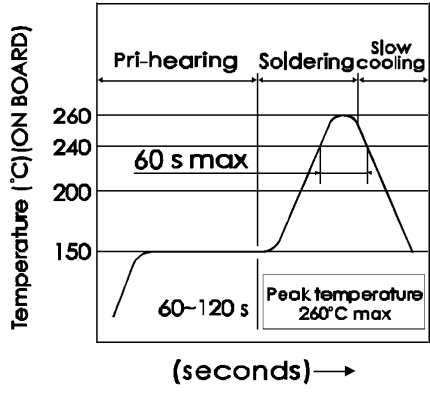
ITEM	SPECIFICATION	TEST METHOD/CONDITION						
Resistance To Soldering Heat	*There shall not be case deformation or change in appearance.  *Variation of inductance shall be within $\pm 3\%$ .  *Must be satisfy electrical characteristics.	The coil shall be passed through the reflow furnace with the condition shown in profile below for 2 times. And then the coil shall be subjected to standard atmospheric conditions for 1 to 2 hours after which measurement shall be made. For other procedures, refer to IEC Pub. 68-20, Test Tb. A temperature does a temperature on a board.  						
Vibration	*There shall not be case deformation or change in appearance.  *Variation of inductance shall be within $\pm 3\%$ .  *Must be satisfy electrical characteristics.	Only endurance conditioning by a frequency sweep shall be made. The entire frequency range, from 10 to 55Hz and return to 10Hz, shall be traversed in 1 minute. Amplitude (total excursion) : 1.5mm This motion shall be applied for a period of 2 hours in each of 3 mutually perpendicular directions (a total of 6 hours).						
Shock		Pulse shape : Half sine Peak acceleration : 981m/s <sup>2</sup> (100G) Duration of the pulse : 6ms  Three successive shocks shall be applied in both directions of 3 mutually perpendicular axis (a total of 6 hours).						
Terminal Pull Strength	There shall not be case deformation or change in appearance. There shall be no evidence of intermittent contact or open circuiting.	A 4.9N load shall be applied to both terminals in the horizontal direction for 1 $\pm$ 0.05 minutes.						
Resistance To Solvents	There shall not be case deformation or change in appearance.	Inductors shall be stored to ISOPROPYL-ALCOHO for 10 minutes respectively.						
		<table border="1" style="width: 100%; border-collapse: collapse;"> <tr> <td style="width: 33%;">APPROVED</td> <td style="width: 33%;">CHECKED</td> <td style="width: 33%;">DRAWN</td> </tr> <tr> <td style="height: 40px;"></td> <td></td> <td></td> </tr> </table>	APPROVED	CHECKED	DRAWN			
APPROVED	CHECKED	DRAWN						

# [SPECIFICATION]

## [POWER INDUCTOR] ( SNR3010F-2R2M-T -PF )

BCNR3010C-2R2M

### ■ Packing

#### • Tape Material-Embossed tape

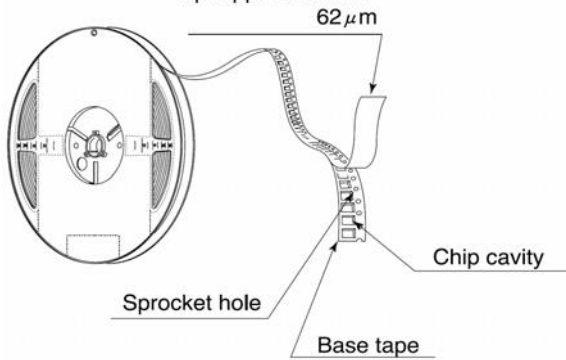

#### • Reel size

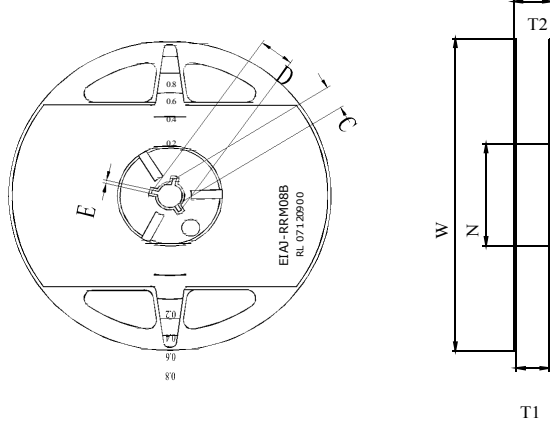

REEL DIMENSIONS UNIT : mm

product series	W	D	C	T1	N	T2
180 $\psi$	178 $\pm$ 2.0	21.0 $\pm$ 0.8	13.0 $\pm$ 0.8	18MAX	50.0MIN	20.5T $\psi$

#### • Leader and Black Portion

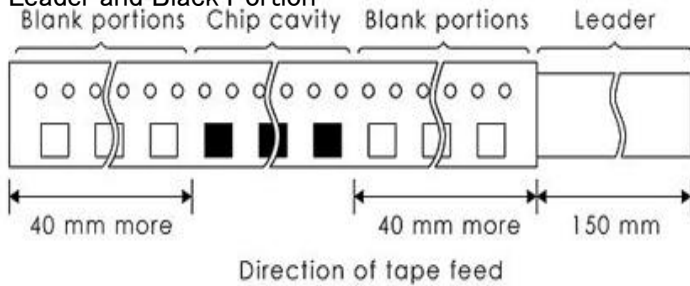

#### • Taping Dimensions

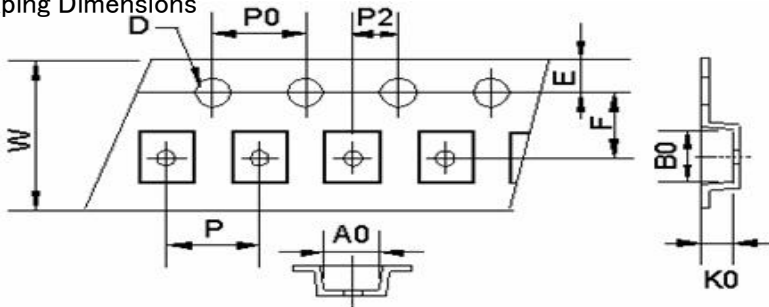

UNIT:mm

Type	SNR3010F
W	8.0 $\pm$ 0.1
AO	3.15 $\pm$ 0.1
BO	3.15 $\pm$ 0.1
KO	1.10 $\pm$ 0.1
D	1.55 $\pm$ 0.05
E	1.75 $\pm$ 0.1
F	3.50 $\pm$ 0.1
P	4.00 $\pm$ 0.1
PO	4.00 $\pm$ 0.1
P2	2.0 $\pm$ 0.1

Reel		4 Reel / Box		2Box / Carton	
Q'ty(Pcs)	Size m/m	Q'ty(Pcs)	Size m/m	Q'ty(Pcs)	Size m/m
2,000	180 $\phi$	8,000	365 $\times$ 365 $\times$ 90	16,000	380 $\times$ 380 $\times$ 230

APPROVED

CHECKED

DRAWN

# [SPECIFICATION]

[POWER INDUCTOR] (BCNR3010C-2R2M)

## ■ Tearing Off Force

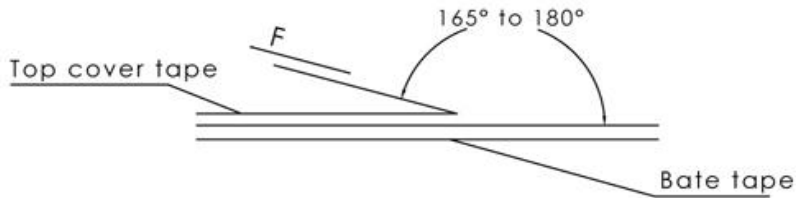

The force for tearing off cover tape is 15to 60 grams in the arrow direction under the following conditions.

Room Temp. (°C)	Room Humidity (%)	Room atm (hPa)	Tearing Speed mm/min
5~35	45~85	860~1060	300

### Application Notice

#### • Storage Conditions

To maintain the solderability of terminal electrodes:

1. Temperature and humidity conditions: Less than 40°C and 70% RH.
2. Recommended products should be used within 6 months from the time of delivery.
3. The packaging material should be kept where no chlorine or sulfur exists in the air.

#### • Transportation

1. Products should be handled with care to avoid damage or contamination from perspiration and skin oils.
2. The use of tweezers or vacuum pick up is strongly recommended for individual components.
3. Bulk handling should ensure that abrasion and mechanical shock are minimized.

## ■ Void Appearance tolerance Limit

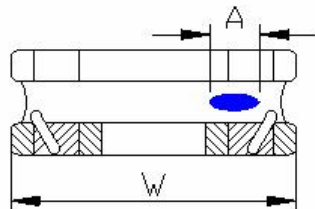

$$A \leq W/2 \text{ GOOD}$$

$$A > W/2 \text{ NG}$$

APPROVED

CHECKED

DRAWN



# [SPECIFICATION]

[POWER INDUCTOR] (BCNR3010C-2R2M)

ITEM

CONTENTS

**1. FLOW SOLDERING**

Flow soldering should be conducted at a temperature of 260 °C or lower for 6 seconds or less.

EX.

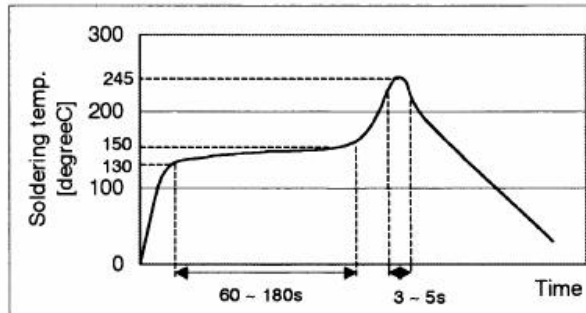

**2. INFRARED REFLOW SOLDERING**

Please implement it with the following condition

Second reflow soldering should be conducted after PCB cool off.

[1] In case of eutectic solder

Preheat: 130~150°C, 60~180s Soldering: 200°Cmin, 70s max.

Peak temp.&time: 230+/-5°C, 5s ※maximum: 250+0/-5°C max.

Time: 2times max.

EX.

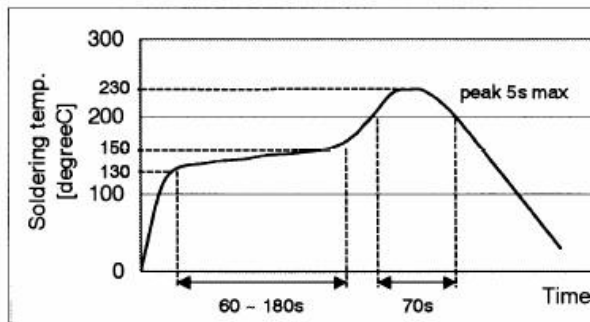

[2] In case of lead-less solder

Preheat: 150~180°C, 60~120s Soldering: 230°Cmin, 40s max.

Peak temp.&time: 255+/-5°C, 10s ※maximum: 260+0/-5°C 10s max.

Time: 2times max.

EX.

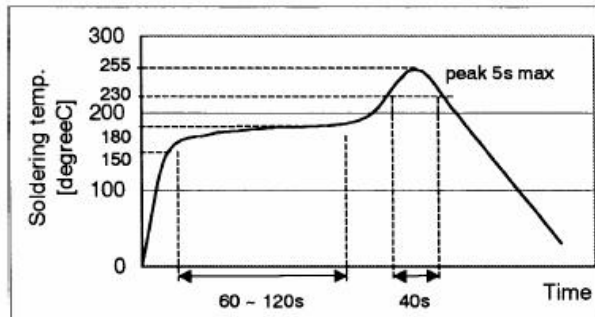

SOLDERING

APPROVED	CHECKED	DRAWN

# [SPECIFICATION]

[POWER INDUCTOR] ( BCNR3010C-2R2M )

## PRECAUTION FOR USE OF POWER INDUCTOR

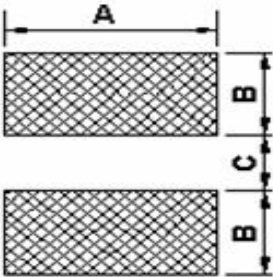
ITEM	CONTENTS								
RESOLDERING WITH A SOLDERING IRON	The temperature of the soldering iron should be 390℃ or less, 5seconds. And resoldering with a soldering iron should be limited to 1time, and after that should be cooling these. Do not touch the resist of grip inductor with the tip of the soldering iron.								
RECOMMENDED LAND DIMENTIONS	 <table border="1" style="margin-left: auto; margin-right: auto;"> <tr> <td style="width: 50px; text-align: center;">A</td> <td style="width: 50px; text-align: center;">3.0</td> </tr> <tr> <td style="text-align: center;">B</td> <td style="text-align: center;">1.0</td> </tr> <tr> <td style="text-align: center;">C</td> <td style="text-align: center;">1.0</td> </tr> </table> <p style="text-align: right;">(m/m)</p>			A	3.0	B	1.0	C	1.0
A	3.0								
B	1.0								
C	1.0								
		APPROVED	CHECKED	DRAWN					

## X-ON Electronics

Largest Supplier of Electrical and Electronic Components

*Click to view similar products for [Fixed Inductors](#) category:*

*Click to view products by [Bao Cheng](#) manufacturer:*

Other Similar products are found below :

[CR32NP-151KC](#) [CR32NP-180KC](#) [CR32NP-181KC](#) [CR32NP-1R5MC](#) [CR32NP-390KC](#) [CR32NP-3R9MC](#) [CR32NP-680KC](#) [CR32NP-820KC](#) [CR32NP-8R2MC](#) [CR43NP-390KC](#) [CR43NP-560KC](#) [CR43NP-680KC](#) [CR54NP-181KC](#) [CR54NP-470LC](#) [CR54NP-820KC](#) [CR54NP-8R5MC](#) [70F224AI](#) [MGDQ4-00004-P](#) [MHL1ECTTP18NJ](#) [MHQ1005P10NJ](#) [MHQ1005P1N0S](#) [MHQ1005P2N4S](#) [MHQ1005P3N6S](#) [MHQ1005P5N1S](#) [MHQ1005P8N2J](#) [PE-51506NL](#) [PE-53601NL](#) [PE-53602NL](#) [PE-53630NL](#) [PE-53824SNLT](#) [PE-92100NL](#) [PG0434.801NLT](#) [PG0936.113NLT](#) [9220-20](#) [9310-16](#) [PM06-2N7](#) [PM06-39NJ](#) [A01TK](#) [1206CS-471XJ](#) [HC2LP-R47-R](#) [HC2-R47-R](#) [HC3-2R2-R](#) [HCF1305-3R3-R](#) [1206CS-151XG](#) [RCH664NP-140L](#) [RCH664NP-4R7M](#) [RCH8011NP-221L](#) [RCP1317NP-332L](#) [RCP1317NP-391L](#) [RCR1010NP-470M](#)