



## Description

The BDH8203 is fabricated from mixed signal CMOS technology. It internally includes an on-chip Hall voltage generator, a voltage regulator for operation with supply voltages of 1.65 to 5.5V, a sleep/awake logic for low power consumption, temperature compensation circuitry, small-signal amplifier, Hall sensor with dynamic offset cancellation system, Schmitt trigger and an open-drain output. Both south pole and north pole of sufficient strength will turn the sensor output on. The output will be turned off under no magnetic field. While the magnetic flux density (B) is larger than operating point (Bop), the output will be turned on (low), the output is held until B is lower than release point (Brp), and then turned off. The total power consumption in normal operation is typically 15µW with a 3.3V power source. Operating temperature range of the BDH8203 is from -40°C to 85°C.

## Features

- CMOS Hall IC Technology
- Strong RF noise protection
- 1.65 to 5.5V for battery-powered applications
- Micropower consumption
- Multi Small Size option
- Low sensitivity drift in crossing of Temp. range Ultra Low power consumption at 5uA (Avg)
- High ESD Protection, HBM> +/- 4KV( min ) Totem-pole output
- Package: TO-92S, SOT23-3

## Application

- Solid state switch
- Handheld Wireless Handset Awake Switch ( Flip Cell/PHS Phone/Note Book/Flip Video Set)
- Magnet proximity sensor for reed switch replacement in low duty cycle applications
- Notebook / PAD PC / PDA

## Functional Block Diagram

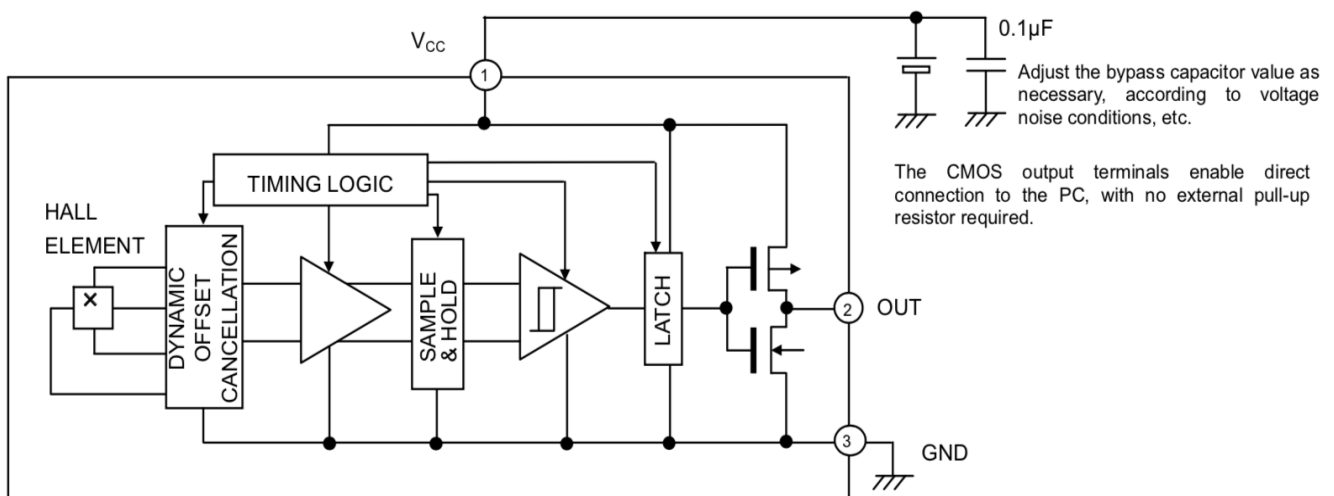



## Typical Application Circuit

Our pole-independent sensing technique allows for operation with either a north pole or south pole magnet orientation, enhancing the manufacturability of the device. The state-of-the-art technology provides the same output polarity for either pole face.

It is strongly recommended that an external bypass capacitor be connected (in close proximity to the Hall sensor) between the supply and ground of the device to reduce both external noise and noise generated by the chopper-stabilization technique. This is especially true due to the relatively high impedance of battery supplies.

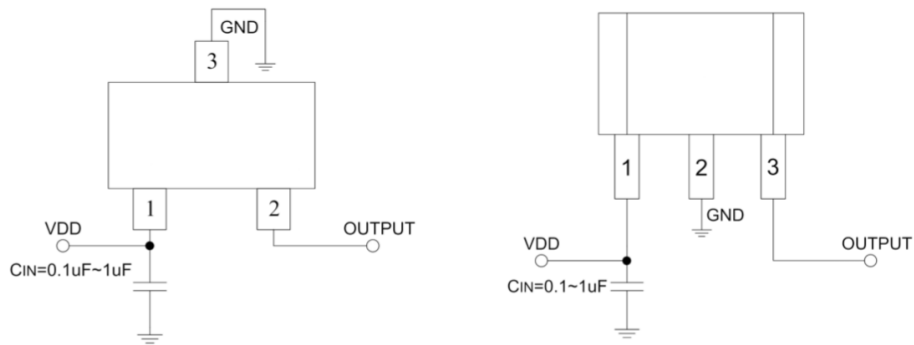

Note:  $C_{IN}$  is for power stabilization and to strengthen the noise immunity, the recommended capacitance is 0.1~1uF.

## Package Information

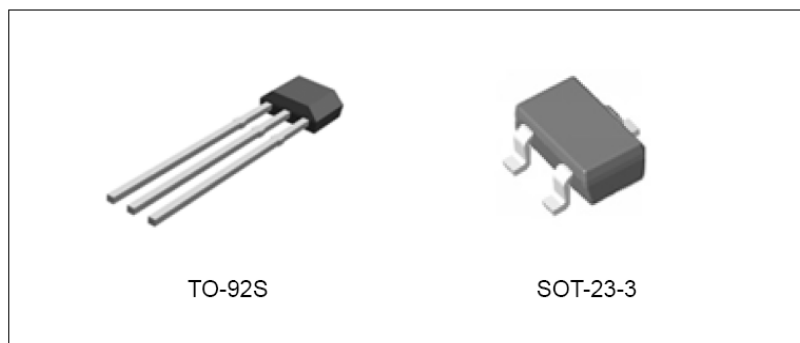

Pin Number		Name	Function
SOT23	TO92S		
1	1	VCC	Supply voltage
2	3	OUT	CMOS Output
3	2	GND	Ground



## Absolute Maximum Ratings (Note 1)

Parameter	Symbol	Value	Unit
Supply Voltage(operating)	$V_{DD}$	6	V
Supply Current	$I_{DD}$	1	mA
Output Voltage	$V_{OUT}$	6	V
Output Curent	$I_{OUT}$	1	mA
Operating Temperature Range	$T_A$	-40 to 85	°C
Storage Temperature Rang	$T_S$	-50 to 150	°C
ESD Sensitivity	-	4000	V

Exceeding the absolute maximum ratings may cause permanent damage. Exposure to absolute-maximum rated conditions for extended periods may affect device reliability.

## DC Electrical Characteristics

DC Operating Parameters:  $T_A = 25^\circ\text{C}$ ,  $V_{DD}=2.75\text{V}$ .

Parameter	Symbol	Test Conditions Conditions	Min	Type	Max	Unit
Operating voltage	$V_{DD}$	Operating	1.65	3.3	5.5	V
Output High Voltage	$V_{OH}$	$B < BrpS$ $I_{OUT} = -0.5\text{mA}$	$V_{DD}-0.2$	-	-	
Output Low Voltage	$V_{OL}$	$BopS < B$ $I_{OUT} = +0.5\text{mA}$	-	-	0.2	
Supply current1	$I_{DD1 (AVG)}$	$V_{DD}=1.8\text{V}$ , Average	-	1.1	-	$\mu\text{A}$
Supply Current During Startup Time1	$I_{DD1 (EN)}$	$V_{DD}=1.8\text{V}$ , During Startup Time Value	-	0.7	-	mA
Supply Current During Standby Time1	$I_{DD1 (DIS)}$	$V_{DD}=1.8\text{V}$ , During Standby Time Value	-	0.42	-	$\mu\text{A}$
Supply current1	$I_{DD1 (AVG)}$	$V_{DD}=3.0\text{V}$ , Average	-	2.4	-	$\mu\text{A}$
Supply Current During Startup Time1	$I_{DD1 (EN)}$	$V_{DD}=3.0\text{V}$ , During Startup Time Value	-	1	-	mA
Supply Current During Standby Time1	$I_{DD1 (DIS)}$	$V_{DD}=3.0\text{V}$ , During Standby Time Value	-	1.4	-	$\mu\text{A}$
Awake mode time	$T_{AW}$	Operating	-	25	-	$\mu\text{S}$
Sleep mode time	$T_{SL}$	Operating	-	50	100	mS



## Magnetic Characteristics

Operating Parameters:  $T_A = 25^\circ\text{C}$ ,  $V_{DD} = 2.75V_{DC}$ .

Symbol	Parameter	Test Conditions	Min.	Typ.	Max.	Units
B <sub>OPS</sub>	Operated point	$T_A = 25^\circ\text{C}$	20	35	50	Gs
		$T_A = -40^\circ\text{C}$ to $85^\circ\text{C}$	-	37	-	
B <sub>OPN</sub>		$T_A = 25^\circ\text{C}$	-20	-35	-50	
		$T_A = -40^\circ\text{C}$ to $85^\circ\text{C}$	-	-37	-	
B <sub>RPS</sub>	Release point	$T_A = 25^\circ\text{C}$	8	23	40	
		$T_A = -40^\circ\text{C}$ to $85^\circ\text{C}$	-	25	-	
B <sub>RPN</sub>		$T_A = 25^\circ\text{C}$	-8	-23	-40	
		$T_A = -40^\circ\text{C}$ to $85^\circ\text{C}$	-	-25	-	
B <sub>HYS</sub>	Hysteresis	$T_A = 25^\circ\text{C}$	-	12	-	
		$T_A = -40^\circ\text{C}$ to $85^\circ\text{C}$	-	12	-	

## Field Direction Definition

A positive magnetic field is defined as a south pole near the marked side of the package.

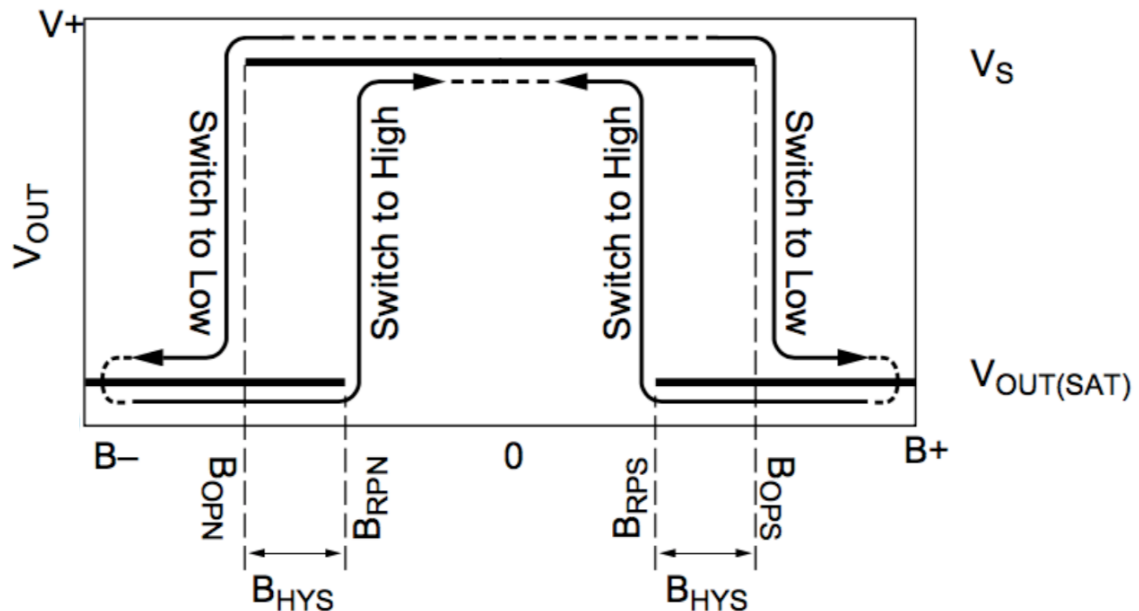

If the device is powered on with a magnetic field strength between  $B_{RP}$  and  $B_{OP}$ , then the device output is determinate High. For all packages, if the field strength is greater than  $B_{OP}$ , then the output is pulled low. If the field strength is less than  $B_{RP}$ , the output is released.



# Performance Characteristics

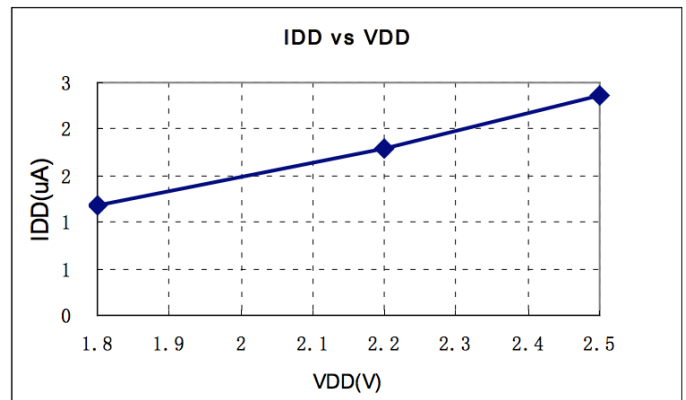
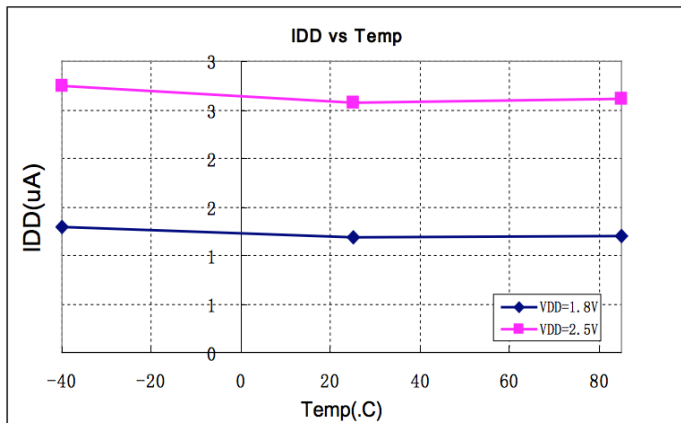
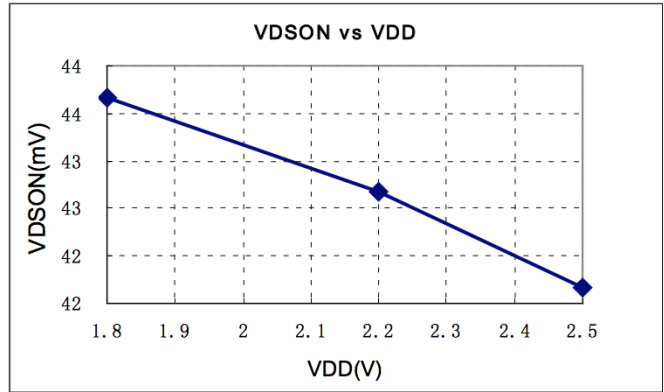
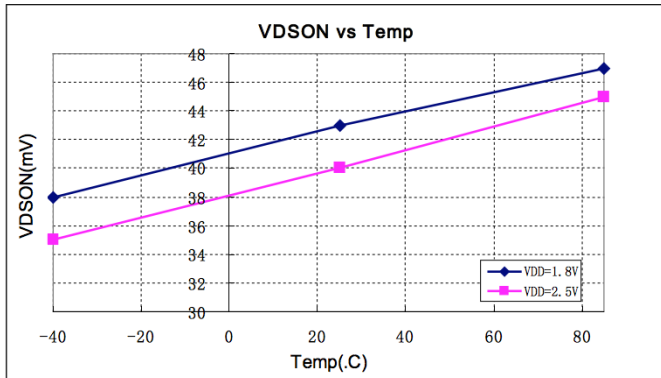
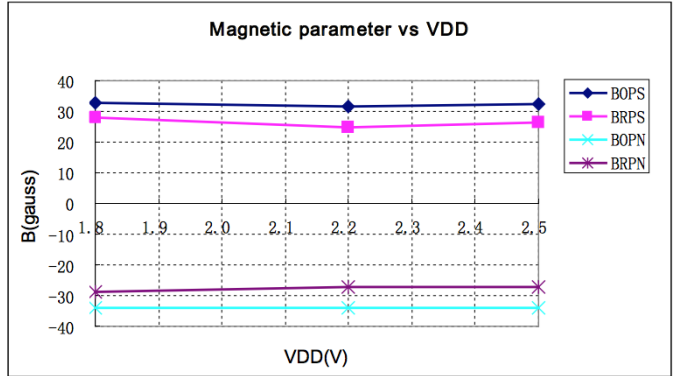
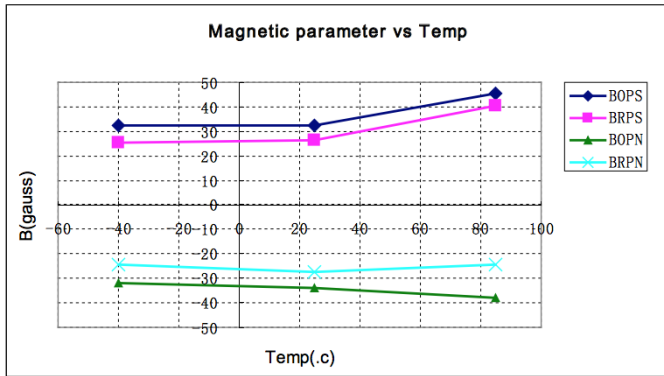

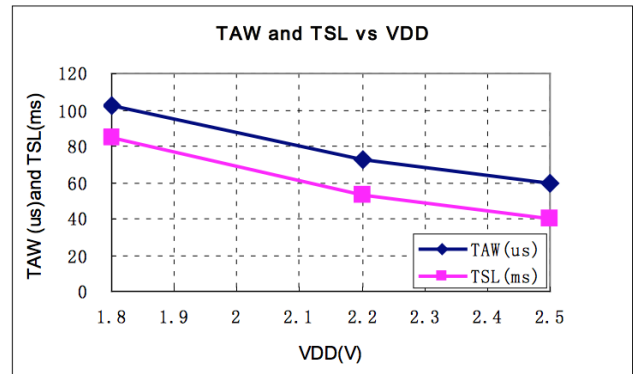
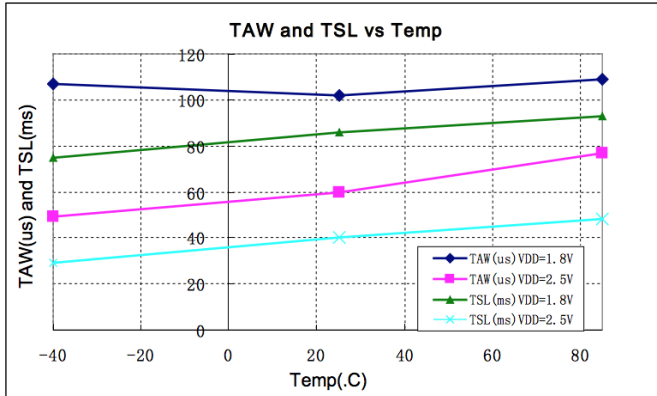

## CMOS Hall IC Technology

The chopper stabilized amplifier uses switched capacitor techniques to eliminate the amplifier offset voltage, which, in bipolar devices, is a major source of temperature sensitive drift. CMOS makes this advanced technique possible. The CMOS chip is also much smaller than a bipolar chip, allowing very sophisticated circuitry to be placed in less space. The small chip size also contributes to lower physical stress and less power consumption.

## Installation Comments

Consider temperature coefficients of Hall IC and magnetics , as well as air gap and life time variations. Observe temperature limits during wave soldering. Typical IR solder-reflow profile:

- No Rapid Heating and Cooling.
- Recommended Preheating for max. 2minutes at 150 C
- Recommended Reflowing for max. 5seconds at 240 C

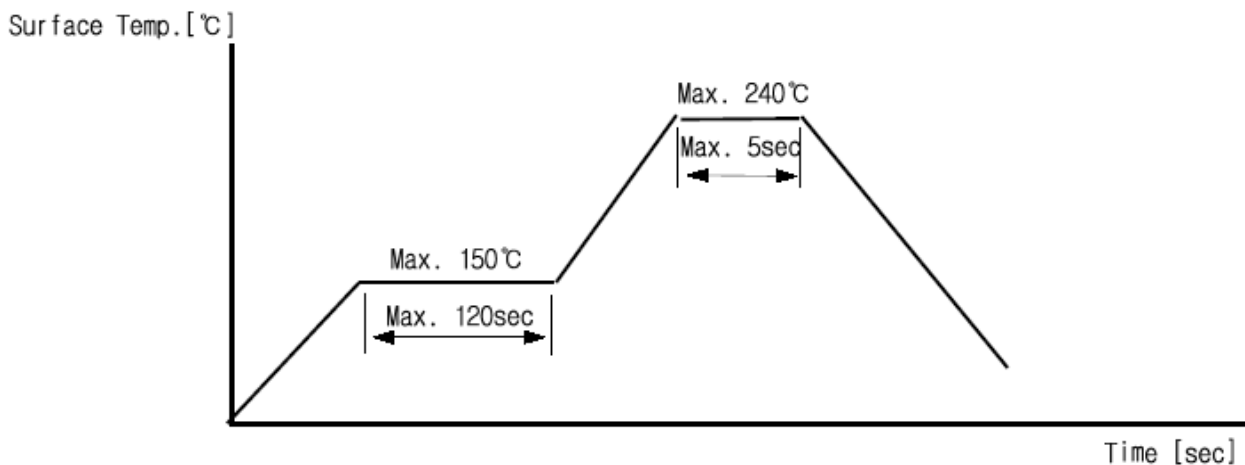



## DESCRIPTION of OPERATIONS

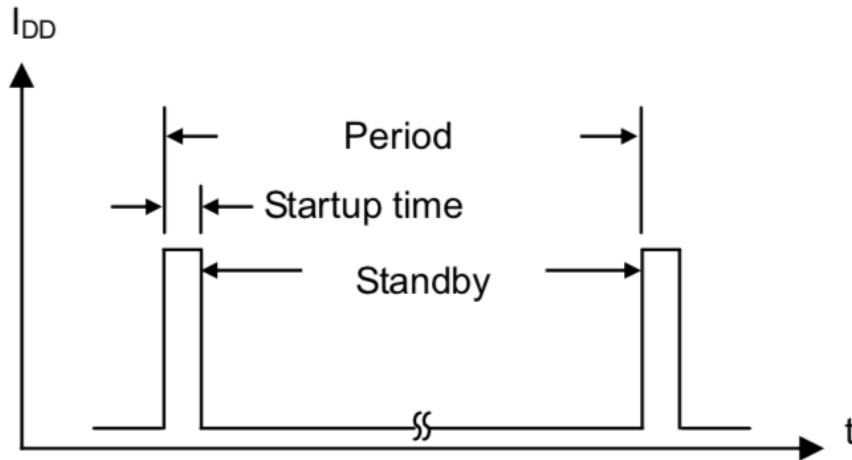

The unipolar detection Hall IC adopts an intermittent operation method to save energy. At startup, the Hall elements, amp, comparator and other detection circuit power ON and magnetic detection begins. During standby, the detection circuits power OFF, thereby reducing current consumption. The detection results are held while standby is active, and then output.

Reference period: 50ms (MAX100ms) Reference startup time: 24 $\mu$ s

### INTERMITTENT OPERATION at POWER ON

The unipolar detection Hall IC adopts an intermittent operation method in detecting the magnetic field during startup, as shown in Fig.5. It outputs to the appropriate terminal based on the detection result and maintains the output condition during the standby period. The time from power ON until the end of the initial startup period is an indefinite interval, but it cannot exceed the maximum period, 100ms. To accommodate the system design, the Hall IC output read should be programmed within 100ms of power ON, but after the time allowed for the period ambient temperature and supply voltage.

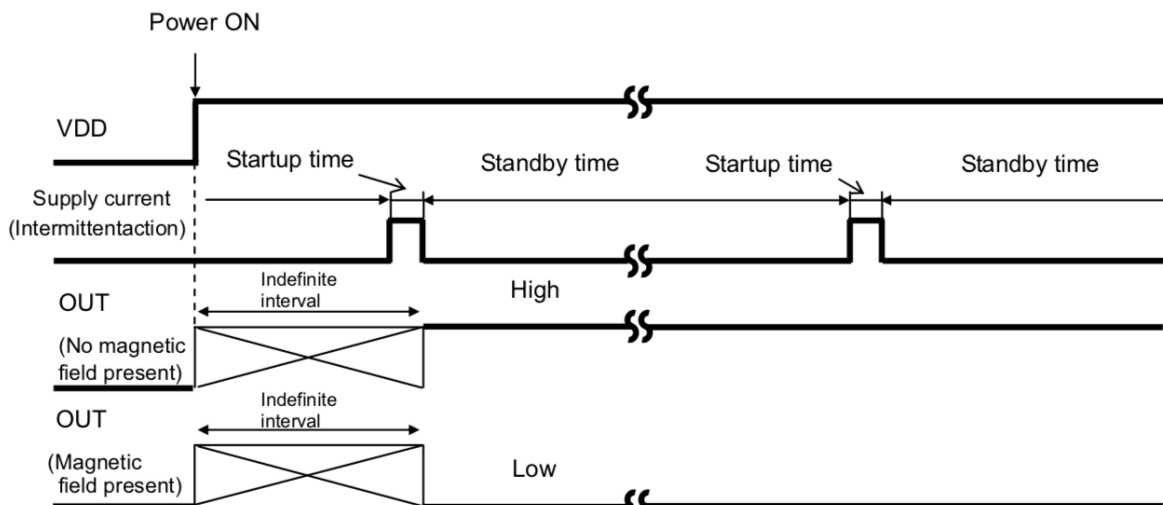



## Package Information

### SOT-23 Package Physical Characteristics

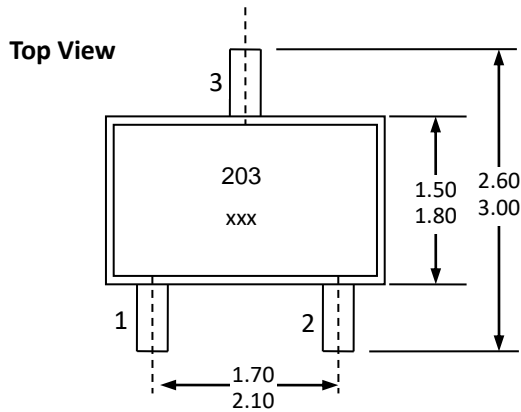

**Notes:**

- 1). PINOUT: Pin 1 VDD  
Pin 2 Output  
Pin 3 GND

2). All dimensions are in millimeters ;

**Marking:**

- 203 -- Code of Device ( BDH8203 ) ;  
XXX: production code

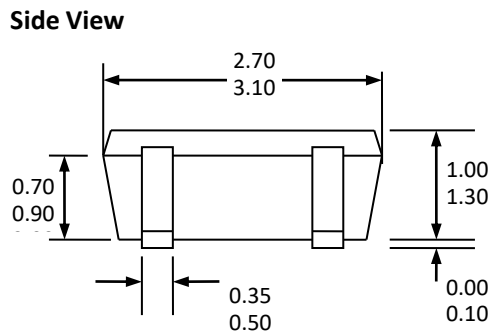

**End View**

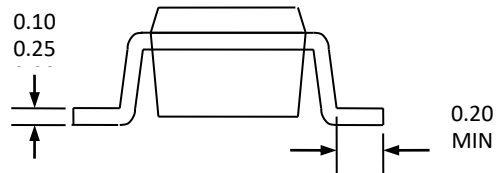

### SOT-23 Package Hall Location

Bottom View of SOT-23 Package

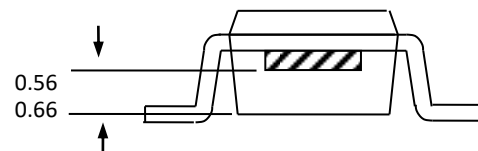
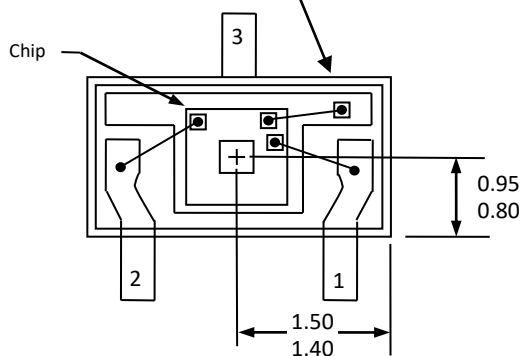







## IMPORTANT NOTICE

Shenzhen Bardeen Microelectronics(BDM) CO.,LTD reserves the right to make corrections, modifications, enhancements, improvements, and other changes to its products and to discontinue any product without notice at any time.

BDM cannot assume responsibility for use of any circuitry other than circuitry entirely embodied in a BDM product. No circuit patent licenses are implied.

Shenzhen Bardeen Microelectronics(BDM) CO.,LTD.

1011,block B, building 6, International innovation Valley, Dashi 1 st Road, Xili Street, Nanshan District ,ShenZhen

Tel: 86-755-23505821

<http://www.bdasic.com>

## X-ON Electronics

Largest Supplier of Electrical and Electronic Components

*Click to view similar products for [Board Mount Hall Effect/Magnetic Sensors](#) category:*

*Click to view products by [Bardeen Micro](#) manufacturer:*

Other Similar products are found below :

[HGPRDT005A](#) [AH277AZ4-AG1](#) [AV-10448](#) [HMC1041Z-TR](#) [SS41C](#) [TLE4917](#) [TLE4946-1L](#) [50017859-003](#) [TY-13101](#) [TLE4976L](#)  
[SS85CA](#) [BU52002GUL-E2](#) [BU52003GUL-E2](#) [AH277AZ4-BG1](#) [TLE49614MXTSA1](#) [AH3376-P-B](#) [TLE4941](#) [AH211Z4-AG1](#) [AH3360-](#)  
[FT4-7](#) [TLE4941-1](#) [AH374-P-A](#) [AH1913-W-7](#) [AH3373-P-B](#) [TLE9852QXXUMA1](#) [MA732GQ-Z](#) [MA330GQ-Z](#) [S-57K1NBL2A-M3T2U](#) [S-](#)  
[57P1NBL9S-M3T4U](#) [S-576ZNL2B-L3T2U](#) [S-576ZNL2B-A6T8U](#) [S-57P1NBL0S-M3T4U](#) [S-57A1NSL1A-M3T2U](#) [S-57K1RBL1A-M3T2U](#)  
[S-57P1NBH9S-M3T4U](#) [S-57P1NBH0S-M3T4U](#) [S-57A1NSH1A-M3T2U](#) [S-57A1NSH2A-M3T2U](#) [S-57K1NBH1A-M3T2U](#) [S-57A1NNL1A-](#)  
[M3T2U](#) [S-5701BC10B-L3T2U5](#) [S-5701BC11B-L3T2U5](#) [S-57GNNL3S-A6T8U](#) [S-57TZ1L1S-A6T8U](#) [S-57GSNL3S-A6T8U](#) [S-](#)  
[5716ANDH0-I4T1U](#) [S-57GSNL5S-L3T2U](#) [S-57GDNL3S-L3T2U](#) [S-57GNNL3S-L3T2U](#) [S-57RBNL8S-L3T2U](#) [S-57RBNL9S-A6T8U](#)