



Model 9PFLST Port-Powered RS-232 Fiber Optic Modem with Handshake Support CE

Description

The 9PFLST allows any two pieces of RS-232 asynchronous serial equipment to communicate full-duplex over two multi-mode fibers. Typical distances up to 2.5 miles (4 km) are possible with no external power required. The 9PFLST supports both data signals at up to 115.2 kbps as well as the RTS/CTS handshake lines. This means the 9PFLST can replace short haul modems and isolators when connecting remote devices, while providing the EMI/RFI and transient immunity of optical fiber.

RS-232 connections are provided on the same DB9 female connector, while the multi-mode fiber is connected via two ST connectors. The unit is port powered by the RS-232 Transmit Data and handshake lines. When handshake lines are not available, or when using a low power RS-232 port, the 9PFLST can be powered by an external 12VDC supply, drawing 50 mA max.

RS-232 Connections

Connection of the 9PFLST is simple and straightforward. The DB9 female serial connector is used for connecting the RS-232 data and handshake signals. The connector is pinned as a DCE device (input on Pin 3 and output on Pin 2.) This means that a straight through cable can be used from your DB9 port from any DTE device such as a PC or terminal. For connecting to modems or other DCE devices, a null modem cable or adapter that swaps pins 2 & 3 is needed. Care should be taken that any output handshake lines be connected through to the 9PFLST to power the unit. See Figure 1 for connection diagrams to 9 pin and 25 pin DTE and DCE devices.

Figure 1: RS-232 Connection Diagrams

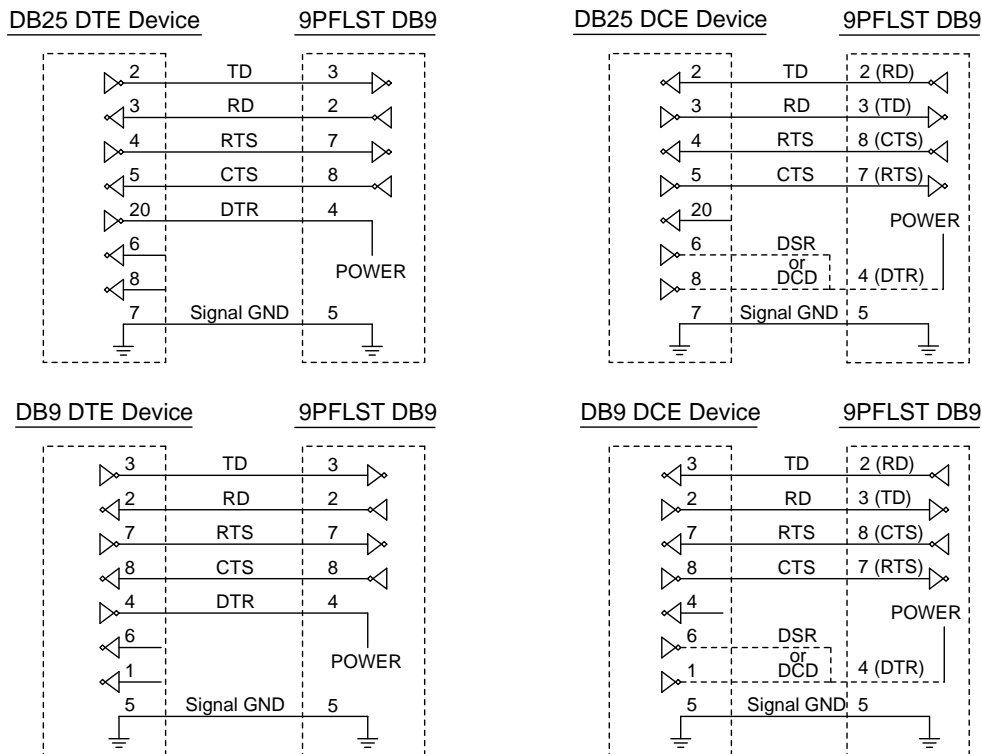

Fiber Optic Connections

The 9PFLST uses a separate LED emitter and photo-detector operating at 820 nm wavelength. Connections to the emitter and detector are on ST type connectors. Almost any multi-mode glass fiber size can be used including 50/125 μm , 62.5/125 μm , 100/140 μm , and 200 μm . Two fibers are required between the two modems, one for data in each direction.

The most important consideration in planning the fiber optic link is the "power budget" of the fiber modem. This value tells you the amount of loss in dB that can be present in the link between the two modems before the units fail to perform properly. This value will include line attenuation as well as connector loss. For the 9PFLST the typical connector-to-connector power budget is 12.1 dB. Because 62.5/125 μm cable typically has a line attenuation of 3 dB per km at 820 nm, the 12.1 dB power budget translates into 2.5 miles (4 km). This assumes no extra connectors or splices in the link. Each extra connection would typically add 0.5 dB of loss, reducing the possible distance by 166 m (547 ft.) Your actual loss should be measured before assuming distances. When the 9PFLST is used without external power, the power available to the Fiber Optic transmitter may be less than the typical value. The link should be tested with the 9PFLST in place with a variable attenuator to check the optical power budget of the whole system.

Figure 2: Typical Setup

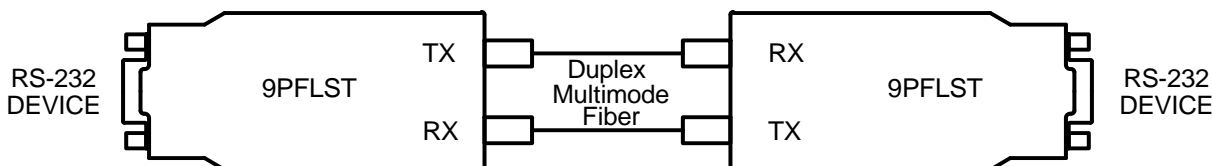

Specifications

Transmission Line:	Dual multi-mode optical cable
Transmission Mode:	Asynchronous, half or full-duplex, point-to-point
Interface:	RS-232
Signals:	Transmit Data, Receive Data, Request to Send, Clear to Send
Data Rates:	0 to 115.2 kbps
Typical Range:	Up to 2.5 miles (4 km) on multi-mode glass fiber
Coupled Power Budget:	12.1 dB
Optic Wavelength:	820 nm
Connectors:	DB9 Female for serial connection, ST Connectors for fiber
Power Supply:	Port Powered from Transmit Data, RTS, and DTR lines
Optional External Power Supply:	10 – 16 VDC @ 50 mA max.
Dimensions:	4.3 x 1.7 x 1.0 in (10.9 x 4.3 x 2.4 cm)

DECLARATION OF CONFORMITY

Manufacturer's Name: B&B Electronics Manufacturing Company
 Manufacturer's Address: P.O. Box 1040
 707 Dayton Road
 Ottawa, IL 61350 USA
 Model Number: 9PFLST
 Description: Port-Powered Fiber Optic Modem
 Type: Light industrial ITE equipment
 Application of Council Directive: 89/336/EEC
 Standards: EN 55022
 EN 61000-6-1
 EN 61000 (-4-2, -4-3, -4-4, -4-5, -4-6, -4-8, -4-11)

Robert M. Paratore, Director of Engineering

Figure 3: 9PFLST Circuit Diagram

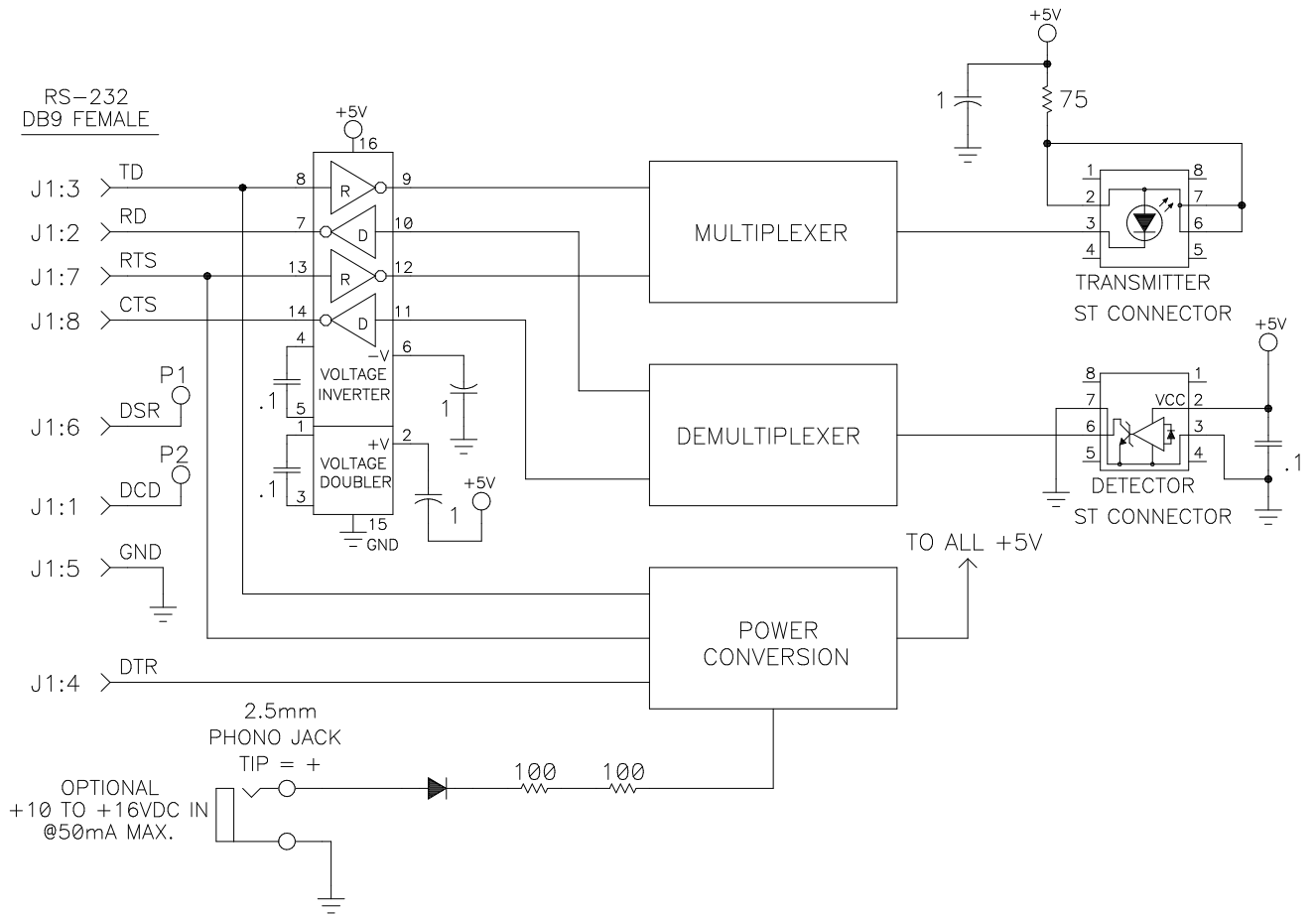

X-ON Electronics

Largest Supplier of Electrical and Electronic Components

Click to view similar products for [Interface Modules](#) category:

Click to view products by [B&B Electronics](#) manufacturer:

Other Similar products are found below :

[IFD8520](#) [cPCI-3544](#) [422CON](#) [ATX6022/14GP7](#) [ATX6022/8](#) [AX93221-24/48](#) [FC6A-EXM2](#) [OPT8AP-AE](#) [96RMKVM-19V1C-A](#) [60016-011](#) [60016-014](#) [60006-008](#) [60011-075](#) [HPCI-14S12U](#) [cBP-3208](#) [cBP-3062A](#) [FAB205-6P5](#) [ATX6022/6](#) [60016-012](#) [96RMKVM-17V1C-A](#) [MOS-1120Y-0201E](#) [96RMLCD-17V1-A](#) [96RMKVM-17V8C-A](#) [60004-005](#) [60016-017](#) [60006-009](#) [60016-035](#) [60016-034](#) [60016-031](#) [60016-030](#) [60016-026](#) [60016-024](#) [60016-018](#) [60016-007](#) [60016-005](#) [60007-002](#) [60006-010](#) [AXX10GBTWLHW3](#) [382-BBEH](#) [555-BDCL](#) [K6CMISZBI52](#) [426451401-3](#) [60011-093](#) [MIC-3620/3-BE](#) [MPCIE-UART-KIT02-R20](#) [RSM232](#) [PCIE-1680-AE](#) [BB-FOSTCDRI](#) [73-544-002](#) [UC-313](#)