

AirborneM2M™ 2.4/5 GHz Dual-band, 802.11x Wi-Fi Enterprise Ethernet Bridge/Router & Serial Server

BB-ABDN-er-se-DP551x model series

ADVANTECH

www.advantech.com



PRODUCT FEATURES

- 10/100 Mbps to 802.11a/b/g/n dual band (2.4 GHz, 5 GHz)
- Wide operating temperature range: -20 to +85 °C
- Compact form factor
- Advanced Enterprise Class wireless security (WPA2-Enterprise, WPA, WEP, EAP)
- 5 VDC external power input (powered from AC or USB port)
- External power supply required
- Available in OEM version (without enclosure)

AirborneM2M enterprise wireless bridges and access routers are built for networking equipment in a wide array of machine to machine (M2M) applications. The compact form factor, integrated options and ease of use make it ideal for commercial enterprise environments.

Dual Band Wi-Fi

These AirborneM2M products establish wireless connections over both 2.4GHz and 5 GHz bands. Whenever the 2.4 GHz airspace is overcrowded with competing wireless transmission, AirborneM2M products can be switched over to the 5 GHz band to keep data flowing.

Enterprise Class Security

Security protocols are important to mission-critical wireless M2M applications. The AirborneM2M multi-layered security approach addresses the requirements of Enterprise-class networks and corporate IT departments. These advanced security features include wireless security (802.11i/WPA2 Enterprise); network security (EAP authentication and certificate support); communication security (SSH functionality and fully encrypted data tunnels); and device security (multi-level encryption capability to protect configuration data).

A 5 VDC external power source is required (see datasheet ordering table for more details, inclusions, ordering options).

ORDERING INFORMATION

MODEL NUMBER	DESCRIPTION	ETHERNET CONNECTOR	POWERING
BB-ABDN-ER-DP551	Ethernet Bridge/Router	RJ45	AC Power Supply included with NATAM cable
BB-ABDN-ER-DP551U	Ethernet Bridge/Router	RJ45	Dual USB port power cable included. (USB powered – 2 open USB ports required)
BB-ABDN-SE-DP551	Serial Server	DB9 male	AC Power Supply included with NATAM cable

World-wide. Check with your local distributor for availability and options.

ACCESSORIES - sold separately

BB-CP-SDS-EURO – Power cord (Europe)

BB-CP-SDS-UK – Power cord (United Kingdom)

BB-ACH2-DBAT-DP002 – 2 dBI - 2.4/5 GHz replacement antenna, rubber duck, RP-SMA

AirborneM2M™ Enterprise Models Operate In A Wide Range of Commercial Applications:

- Medical Devices
- Retail / Point-of-Sale
- Material Handling & Logistics
- Test & Measurement
- Security & Access Control

All product specifications are subject to change without notice.
BB-ABDN-er-se-DP551x_ENTPR_EthBrRtr-SerSvr_4720ds

ADVANTECH

Advantech B+B SmartWorx, 707 Dayton Road, PO Box 1040 Ottawa, IL 61350 USA 1 (800)346-3119/Toll Free | orders@advantech-bb.com | support@advantech-bb.com

AirborneM2M™ 2.4/5 GHz Dual-band, 802.11x Wi-Fi Enterprise Ethernet Bridge/Router & Serial Server

BB-ABDN-er-se-DP551x model series



BB-ABDN-SE-DP551

SPECIFICATIONS

TECHNOLOGY	
Technology	IEEE 802.11a/b/g/n, Wi-Fi compliant
Wired Interface	10/100 Ethernet Port – Bridge, Router (NAT3) Modes
Frequency	2.4 ~ 2.4835 GHz (US/Canada/Europe) 5.150 ~ 5.350 GHz 5.725 ~ 5.825 GHz
Modulation Technology	DSSS, CCK, OFDM
Modulation Type	DBPSK, DQPSK, CCK, BPSK, QPSK, 16QAM, 64QAM
Network Access Modes	Infrastructure (Client), Ad Hoc
Channels	US/Canada: 11 Channels 802.11b/g 13 Channels 802.11a
	Europe: 13 Channels 802.11b/g 19 Channels 802.11a
	France: 4 Channels 802.11b/g
Wireless Data Rate	802.11b = 11, 5.5, 2, 1 Mbps 802.11a/g = 54, 48, 36, 24, 18, 12, 9, 6 Mbps 802.11n = 65, 58.5, 42, 39, 26, 19.5, 13, 6.5 Mbps
MAC	CSMA/CA with ACK, RTS, CTS
Network Protocols	TCP/IP, ARP, ICMP, DHCP, DNS, UDAP, TFTP, UDP, PING
Receive Sensitivity – 802.11b/g	54Mb/s = -72 dBm
	36Mb/s = -78 dBm
	18Mb/s = -84 dBm
	6Mb/s = -89 dBm
	11Mb/s = -86 dBm
Receive Sensitivity – 802.11a	54Mb/s = -74 dBm
	36Mb/s = -80 dBm
	18Mb/s = -86 dBm
	6Mb/s = -90 dBm
Dimensions	6.12 x 9.96 x 3.18 cm (2.41 x 3.92 x 1.25 in)

MECHANICAL DIAGRAM

Units = inches

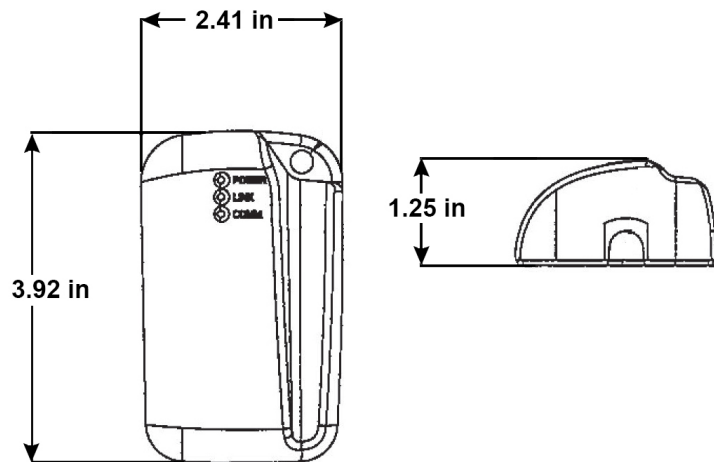

FEATURES	
Transmit Power	802.11b = 15 dBm (31.6mW) 802.11g = 12.6 dBm (18.12mW) 802.11a = 17 dBm (50.1mW)
Security Protocols	Disabled, WEP 64 & 128-bit, WPA (TKIP), WPA (AES), WPA2 (AES), 802.1x (EAP) Supplicant 802.11i, WPA & WPA2 Enterprise supplicants (EAP-TLS, EAP-TTLS(MSCHAPv2), EAPTTLS (MDS5), EAP-PEAPv0 (MSCHAPv2, LEAP), EAP-FAST, LEAP) Supports Certificates and Private Key Upload and Storage (multiple)
Antenna	Integrated RP-SMA Omni-directional 2dBi 2.4/5 GHz Antenna
Powering	5.0 VDC +/-5% power supply USB (2 open USB ports required; dual USB port power cable included) Note: external power source required - see ordering table.
Current	Normal operation: 1000 mA (maximum) Supply In-rush: 3000 mA (maximum) for 20ms
DC Characteristics	Operating Current (TX, 802.11g) = 370mA (typical) Operating Current (RX, 802.11g) = 200mA (typical) Operating Current (TX, 802.11a) = 550mA (typical)
Environmental	Operating Temperature: -20 to +85 °C Storage Temperature: -20 to +85 °C Relative Humidity: 5 to 95% (non-condensing)
Interfaces	10/100 Ethernet
Enclosure	Nylon (gray), cradle base
LED Indicators	3 LED Indicators (Power, LINK, COMM)
MEANTIME BETWEEN FAILURES (MTBF)	
MTBF	BB-ABDN-ER-DP551 = 422655 hours BB-ABDN-ER-DP551U = 422655 hours BB-ABDN-SE-DP551 = 444758 hours
MTBF Calc Method	MIL 217F (Parts Count Reliability Prediction)
REGULATORY	
North America	FCC Title 47 Part 15 Class B Sub C Intentional Radiator
CE - Directives	2014/35/EU - Low Voltage Directive 2014/53/EU - Radio Equipment Directive (RED) Hereby, Advantech B+B SmartWorx declares that the radio equipment type Wi-Fi Ethernet Bridge/Router and Serial Server are in compliance with Directive 2014/53/EU. The full text of the EU Declaration of Conformity is available at the following internet address: www.advantech-bb.com 2011/65/EU - amended by (EU) 2015/863 Reduction of Hazardous Substances Directive (RoHS) 2012/19/EU - Waste Electrical & Electronic Equipment Directive (WEEE)
	EMC: ETSI EN 300 328 v2.1.1 - EMC & Radio Spectrum Matters (ERM) Wideband Transmission Systems - 2.4 GHz ISM Band ETSI EN 301 893 v2.1.1 - EMC & Radio Spectrum Matters (ERM) Wideband Transmission Systems - 5 GHz ISM Band ETSI EN 301 489-1 v2.1.1 - Applied in accordance with the specific requirements of: ETSI EN 301 489-17 v3.1.1 - EMC & Radio Spectrum Matters (ERM) Broadband Data Systems EN 55032+AC, Class A - Information Technology Equipment (ITE) - RF Emissions EN 55024 - Information Technology Equipment (ITE) - Immunity Characteristics - Limits and Methods of Measurement
	Safety: EN 60950-1 + A1 + A11 + A12 + A2 - Information Technology Equipment (ITE) - Safety - Part 1: General Requirements
	RF Exposure: EN 62311 - Assessment of electronic and electrical equipment related to human exposure restrictions for EM fields (0 Hz to 300 GHz)

X-ON Electronics

Largest Supplier of Electrical and Electronic Components

Click to view similar products for [Servers](#) category:

Click to view products by [B&B Electronics](#) manufacturer:

Other Similar products are found below :

[70002259](#) [70002261](#) [VESR321-ML](#) [NBLM-LM1CR](#) [EKI-1528TI-VDC-CE](#) [ADAM-4570L-DE](#) [ADAM-4571-CE](#) [XPC100200S-01](#) [ESP904](#)
[96NIC-10G2P-IN](#) [ADAM-4570-CE](#) [ADAM-4571L-DE](#) [EKI-1361-MB-BE](#) [EKI-1362-BE](#) [EKI-1362-MB-BE](#) [EKI-1521-CE](#) [EKI-1522-CE](#)
[EKI-1524-CE](#) [EKI-1524I-CE](#) [EKI-1526-CE](#) [EKI-1526I-CE](#) [EKI-1528-CE](#) [ABDN-ER-IN5018](#) [ESP901](#) [ESP902](#) [ESR901](#) [ESR902](#) [ESR904](#)
[BB-VESR902T](#) [VESR902D](#) [VESR902T](#) [70002412](#) [70002263](#) [70002265](#) [70002269](#) [70002271](#) [70002277](#) [70002279](#) [70002281](#) [70002285](#)
[70002404](#) [70002406](#) [70002410](#) [70002414](#) [70002418](#) [ED1100002-01](#) [ED2100002-01](#) [ED41000P0-01](#) [ED41000P2-01](#) [PEN100100A-01-IT](#)