

BB-WCD1H2102H BB-WCD1H3001HP100

Wzzard™ Mesh Wireless Sensor Monitoring Nodes – Commercial Applications



Features

- Ultra-low power 802.15.4e SmartMesh IP technology
- Communicates with SmartSwarm 342 gateway via a highly scalable and reliable wireless mesh network
- Internal temperature & humidity sensing support
- Connect to industry standard analog or digital sensors
- MQTT and JSON IoT protocol to application platform
- Wide operating temperature range
- Monitor refrigeration, food processing/storage or light stacks

Introduction

Wireless Connectivity Where You Need It

The Wzzard mesh intelligent wireless sensor platform creates a complete, quick and easy connectivity stack between your sensors and your application, on your network or on the Internet. The platform uses Wzzard mesh wireless sensor nodes and a wireless 802.15.4e SmartMesh IP network to transmit sensor data to the gateway. The SmartSwarm 342 gateway connects to the Internet via wired connections or cellular data networks.

Reliable, Highly Scalable Wireless Network

The Wzzard Mesh platform uses mesh networking and time-synchronized channel hopping to provide up to 99.999% connectivity, even in demanding RF environments. New nodes may be added at any time – the SmartMesh IP network will dynamically self-configure as nodes are added or removed. This is a function of the mesh network itself and does not need to be controlled by the network gateway. One gateway can support up to 100 nodes.

Easy Installation and Configuration

Non-intrusive - even portable - network “overlay” is easy to install and remove with no disruptions to your existing network and no downtime. Configuration of the Wzzard mesh sensor platform is easy via the Advantech hub cloud management portal.

Ordering Information

Model No.	Description
BB-WCD1H2102H	Wzzard Mesh Wireless 802.15.4e Sensor Node – HVAC/Cooler Node for Temperature & Humidity Sensing – 2 AI, 1 DI, 1 Thermistor, Internal Temperature & Humidity, Internal Antenna
BB-WCD1H3001HP100	Wzzard Mesh Wireless 802.15.4e Sensor Node – Commercial Stacklight Node for Light Sensing – 3 AI, vBat Out, Internal Antenna – Internal Temperature & Humidity supported

Accessories – Sold Separately

– Or included with select Wzzard starter kits (see kit/s below for details)

BB-WCHMS – Door sensor cable (open/close)

BB-WCHCBL – Thermistor/Breakout sensor cable

BB-LSSCBL – Light sensor cable (stack light)

BB-JC10F50V – 50A clamp-on current sensor (compressor, fan)

Dimensions

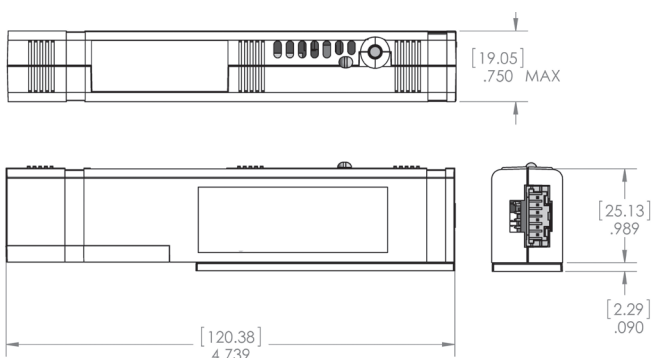

Starter Kits Available

Everything you need to get started – easy to expand later.



Refrigeration/Cooler Monitoring

Model# BB-WSK-REF-2

- 1 - Wzzard wireless node - temperature & humidity (# BB-WCD1H2102H)
- 2 - Clamp-on current sensors (# BB-JC10F50V)
- 1 - 10K thermistor for temperature (# BB-WCHCBL)
- 1 - Door open/close sensor (# BB-WCHMS)
- 1 - SmartSwarm 342 Gateway



Stack Light Monitoring

Model# BB-WSK-SLM-2

- 1 - Wzzard wireless node - light (# BB-WCD1H3001HP100)
- 1 - Stack Light Sensor Cable (# BB-LSSCBL)
- 1 - SmartSwarm 342 Gateway





Specifications

Technology	
Wireless	802.15.4e, SmartMesh IP
LED	Network Connectivity, Node Status
Power	
Internal	3.6V 1650 mAh Lithium Thionyl Chloride 2/3 AA battery
Battery Life	5-year battery life, based on 1 minute sensor sampling interval
Mechanical	
Physical Connection	Molex® 6-pin MicroClasp™
Antenna	Internal
Mounting Options	Mounting bracket (included), VHB adhesive strip (included), or zip tie (ties not included)
Dimensions	120.38l x 27.42h x 19.05d mm (4.74l x 1.08h x 0.75d in)
Weight	0.09 kg (0.2 lb)
Wireless Security	
Device Authentication	
128-bit AES-based encryption with multiple keys	
Message Integrity Check (MIC)	
Synchronized Key Changeovers	
Customized Key Rotation	
Thionyl Chloride Lithium Battery* (1 supplied with product)	
Temperature Range	-60 to +85 °C
Nominal Capacity	1.65 Ah
Nominal Voltage	3.6 V
Diameter	14.5 mm
Height	33.5 mm
*Potential Hazard: Do not recharge, crush, disassemble or heat above +100°C (+212°F)	
Environmental	
Installation	Indoor
Operating Temperature	-20 to +70 °C (-4 to +158 °F)
Storage Temperature	-40 to +85 °C (-40 to +187 °F)
Operating Humidity	0 to 95%, non-condensing

Regulatory – Approvals / Standards / Directives	
FCC Part 15, 15.247, Class B Industry Canada - RSS210	
CE - Directives	2014/35/EU Low Voltage Directive 2014/53/EU Radio Equipment Directive 2011/65/EU amended by (EU) 2015/863 - Reduction of Hazardous Substances Directive (RoHS) 2012/19/EU Waste Electrical and Electronic Equipment (WEEE)
CE - Standards	EMC: ETSI EN 300 328 v2.1.1 - EMC & Radio Spectrum Matters (ERM) Wideband Transmission Systems, 2.4 GHz ISM Band ETSI EN 301 489-1 V2.1.1 - Applied in accordance with the specific requirements of: ETSI EN 301 489-17 V3.2.0 - EMC and Radio Spectrum Matters: Broadband Data Systems EN 55032 +AC, Class A Information technology equipment – RF Emissions EN 55024 Information Technology Equipment – Immunity Characteristics – Limits and methods of measurement Safety: EN/IEC 61010-1 3rd Ed. Safety requirements for electrical equipment for measurement, control, and laboratory use. General requirements EN/IEC 61010-2-201 1st Ed. Particular requirements for control equipment RF Exposure: EN 62479 - Assessment of the compliance of low power electronic and electrical equipment with the basic restrictions related to human exposure to electromagnetic fields (10 MHz to 300 GHz)
Standards - other	EN 61000-6-2 - Generic Immunity Standard for (Heavy) Industrial Environments EN 61000-6-4 + A1 - Emission Standard for (Heavy) Industrial Environments EN 60255-21-1 - Vibration, 2g, 10-500 Hz, 1.5mm displacement EN 60255-21-2 - Shock, 50g, 11ms half sine wave, 18 shocks IEC 60068-2-31 - Drop

SmartMesh IP 802.15.4e Radio Specifications

Parameter	Conditions	Minimum	Typical	Maximum	Units
Frequency Band		2.400		2.4835	GHz
Number of Channels			15		
Channel Separation			5		MHz
Channel Clear Frequency	Where k = 11 to 25, as defined by IEEE 802.4.15		2405 + 5*(k-11)		MHz
Modulation	IEEE 802.15.4 Direct Sequence Spread Spectrum (DSSS)				
Raw Data Rate			250		kbps
Range	Indoor		100		m
	Outdoor		200		m
Receiver Sensitivity	Packet Data Error Rate (PER) = 1%			-93	dBm
Receiver Sensitivity	PER = 50%			-95	dBm
Conducted Output Power (PA on)	Delivered to a 50 Ω load		8		dBm
Conducted Output Power (PA off)	Delivered to a 50 Ω load		0		dBm
Radiated Output Power (PA on)	Taoglas PA.11.BB antenna		7		dBm
Radiated Output Power (PA off)	Taoglas PA.11.BB antenna		-1		dBm



BB-WCD1H2102H BB-WCD1H3001HP100

BB-WCD1H2102H – Sensor Interface Specifications

Analog Inputs						
Input Range	0 - 10V DC / 0-20 mA (software selectable)					
Resolution	0.3 mV / 1.3 μ A					
Input Load Resistance	59 K Ohms / 250 Ohms					
Accuracy	+/-25 mV +/-0.05 mA					
Number of Analog Inputs	2					
Thermistor Input						
Types Supported	10K @ +25 $^{\circ}$ C					
Ranges Supported	-40 to +85 $^{\circ}$ C					
Resolution	0.05 $^{\circ}$ C					
Accuracy	Typical \pm 0.3 $^{\circ}$ C @ +25 $^{\circ}$ C					
Number of Thermistor Inputs	1					
Digital Inputs						
Voltage Range	0 - 48V DC					
V _{IL}	0.4 V, maximum					
V _{HI}	2.5 V, minimum					
Pull-up Current	65 μ A					
Type	Sinking (NPN) Input					
Isolation	None					
Number of Digital Inputs	1					
Integrated Sensors - inside of node						
Humidity Sensor						
Accuracy	4%, relative humidity					
Response Time	80% response within 10 minutes					
Number of Humidity Sensors	1					
Temperature Sensor		Conditions	Minimum	Typical	Maximum	Units
Offset	Temperature Offset Error @ +25 $^{\circ}$ C			\pm 0.25		$^{\circ}$ C
Slope Error				\pm 0.033		$^{\circ}$ C / $^{\circ}$ C

BB-WCD1H3001HP100 – Sensor Interface Specifications

Analog Inputs	
Input Range	0 - 10 VDC
Resolution	0.3 mV
Input Load Resistance	59 K Ohms
Accuracy	+/-25 mV
Number of Inputs	3
Sensor Power	
Power to Sensor	Switched vBat Out
Integrated Sensors - inside of node	
Humidity Sensor	
Accuracy	4% RH
Response Time	80% response within 10 minutes

X-ON Electronics

Largest Supplier of Electrical and Electronic Components

Click to view similar products for [Zigbee Modules - 802.15.4 category](#):

Click to view products by [B+B SmartWorx manufacturer](#):

Other Similar products are found below :

[XBP24-ASI-080](#) [ATZB-RF-212B-0-CNR](#) [34560-894](#) [32411](#) [32416](#) [32406](#) [E18-MS1PA2-PCB](#) [ZTU\(ujzh\)](#) [BB-WCD1H2102H](#) [BB-WCD1H3001HP100](#) [BB-WSD2C31010](#) [BB-WSD2M31010](#) [BB-WSK-SLM-2](#) [BB-WSD2C21150](#) [BB-WSK-CBM-2](#) [XB3-24Z8CM-J](#) [20848674](#) [BB-WSD2M3101P2K](#) [WSD2M06010](#) [ATZB-X0-256-3-0-C](#) [BB-WCD1H2102H](#) [BB-WSD2C21150](#) [BB-WSD2M31010](#) [WSD2CTJ](#) [WSD2MD2](#) [WPMM1A01A](#) [WPMM1A02A](#) [ATZB-RF-233-1-CR](#) [ATSAMR21G18-MR210UA](#) [ATSAMR21G18-MR210UAT](#) [MRF24J40MA-I/RM](#) [MRF24J40MD-I/RM](#) [AX-SF10-ANT21-868-B1](#) [AX-SF10-MINI21-868-B1](#) [24572054](#) [114990002](#) [EM351-MOD-ANT-T](#) [EM357-MOD-ANT-T](#) [ETRX3587HR](#) [WPMM1A00A](#) [ZICM35XSPX-PF-1](#) [ATZB-RF-212B-0-CN](#) [WMPR1A00B1A2](#) [WMPR1A02B1A2](#) [WMPR1A00B1A1](#) [WMPR1A02B1A1](#) [WPMM1A01B](#) [WPMM1A02AS01](#) [WMPR1A02A1A1](#) [CGW-Z-0010-01-00](#)